

INTEGRATED RECTANGULAR DUCT FAN

Rev.01
27-05-2015



GMC DCF-507:

Integrated rectangular duct fan. The range consists of 9 sizes and covers an air flow range from 1740 up to 10050 m³/h

Application

- For ventilation of offices, restaurants, garages, work shops

Composition

- The casing is made of galvansed sheet steel
- Integrated thermal switch
- Big access door enables easy acces to terminal box and fan
- Removable fan section
- Speed controllable
- Protection class IPX4
- Isolation Class F

Accessories

- Speed controllers **MTY**, **STL** and **BTRN**

Order example

- DCF-507: Mk.5030 01 + BTRN-1-2

5030: duct dimensions (500x300)
BTRN-1-2: type of controller



HVAC Systems and Equipments Co.
4640 Hedgcoxe Road 227 Plano, TX 75024 – US

www.gmcair.com 

INTEGRATED RECTANGULAR DUCT FAN

Rev.01
27-05-2015



Air Performance Data

Model	Qv [m³/h]									
	0Pa	100Pa	200Pa	300Pa	400Pa	500Pa	600Pa	700Pa	800Pa	900Pa
Mk. 5025 01	1735	1590	1365	495	225	-	-	-	-	-
5030 01	2420	2255	2035	1700	700	350	50	-	-	-
6030 01	2400	2230	2025	1690	570	300	0	-	-	-
6030 02	4890	4585	4180	3490	1145	625	125	-	-	-
6035 01	3500	3300	3080	2815	2480	790	470	135	-	-
6035 02	4935	4610	4140	3515	1100	575	20	-	-	-
6035 03	4970	4770	4525	4260	3900	3480	1235	840	480	130
7040 01	7125	6735	6240	5610	4715	1580	915	130	-	-
8050 01	10050	9610	9125	8580	7865	6975	2615	1745	1020	350

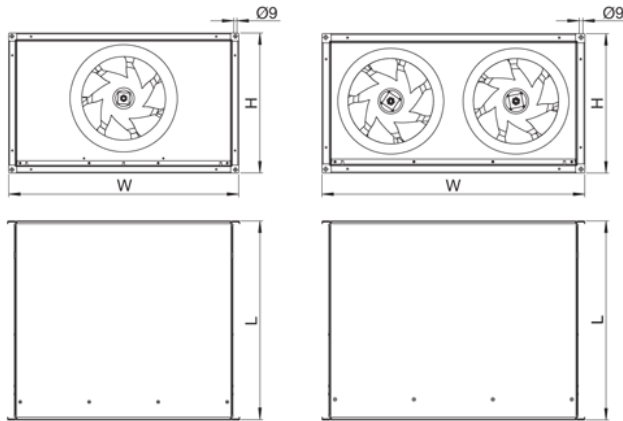

- DCF-507:Mk. 5025 01
- DCF-507:Mk. 5030 01
- DCF-507:Mk. 6030 01
- DCF-507:Mk. 6035 01
- DCF-507:Mk. 6035 02
- DCF-507:Mk. 6035 03

- DCF-507:Mk. 6030 02
- DCF-507:Mk. 7040 01
- DCF-507:Mk. 8050 01

Dimensions

Mk.	Model	Fans (pcs)	L (mm)			W (mm)			H (mm)			[Kg]
			1	2	3	1	2	3	1	2	3	
	5025 01	1	483			538			268			14,50
	5030 01	1	483			538			338			17,10
	6030 01	1	483			638			338			18,30
	6030 02	2	483			638			338			26,10
	6035 01	1	483			638			338			25
	6035 02	2	483			638			338			26,90
	6035 03	1	483			638			338			27,10
	7040 01	2	483			738			438			44
	8050 01	2	483			738			538			51,60

