

A CLOSER LOOK...

- Easy-to-adjust mechanical stop to limit damper rotation.
- Cut labor costs with simple direct coupling. Actuator Centers on 1/2" shaft.
- Clockwise or counterclockwise fail-safe mounting for fail-safe.
- Compact size with the shortest shaft-center to edge distance in the industry - 0.77".
- True mechanical spring return – the most reliable fail-safe.
- Single line voltage model for on/off application has 100 to 240V (-15/+10%), 50/60 Hz supply power.
- Check damper position easily with clear position indicator.
- Don't worry about actuator burn-out. Belimo is overload-proof throughout rotation.
- Need to change control direction? Do it easily with a simple switch (modulating actuators).
- Built-in auxiliary switch is easy to use, offers feedback or signal for additional device.
- Microprocessor-controlled brushless DC motor increases actuator life span and reliability, provides constant running time (modulating actuators).
- Rugged housing withstands rough handling in the mechanical room.
- 3 ft. standard cable and conduit connector (not shown) eases installation.

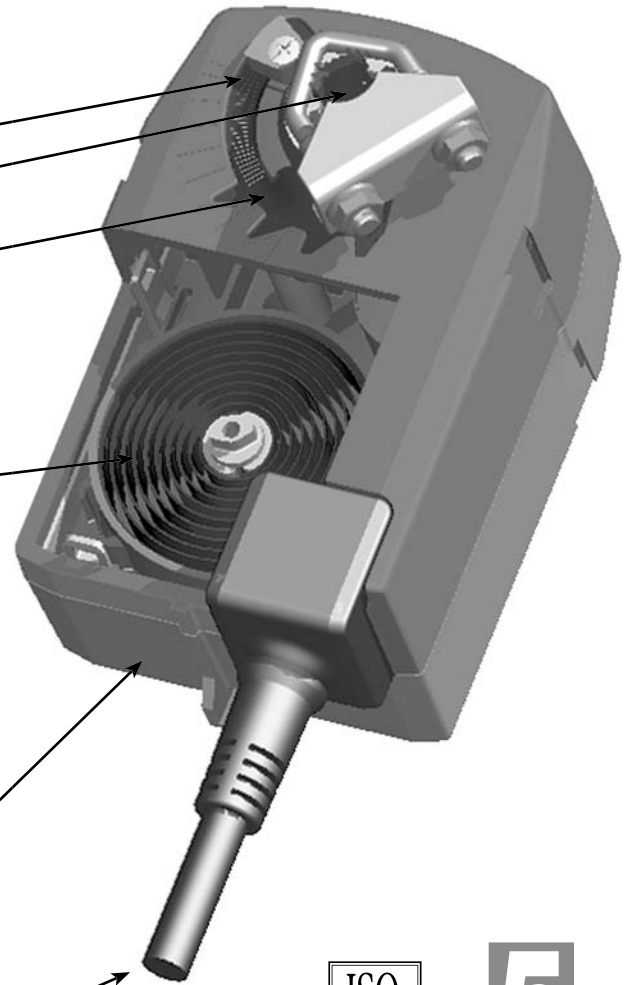

M40103 - 09/11 - Subject to change. © Belimo Aircontrols (USA), Inc.

The Belimo Difference

- **Customer Commitment.**
Extensive product range. Application assistance.
Same-day shipments. Free technical support. Five year warranty.
- **Low Installation and Life-Cycle Cost.**
Easy installation. Accuracy and repeatability.
Low power consumption. No maintenance.
- **Long Service Life.**
Components tested before assembly. Every product tested before shipment.
30 years direct coupled actuator design.

TFB24(-S), TFX24(-S)

On/Off, Spring Return, 24 V



Technical Data		TFB24(-S), TFX24(-S)
Power supply		24VAC ± 20%, 50/60Hz 24VDC ± 10%
Power consumption	running	2 W
	holding	1.3 W
Transformer sizing		5 VA (class 2 power source)
Electrical connection	TFB24...	3 ft, 18 GA appliance cable, 1/2" conduit connector -S models: two 3 ft, 18 gauge appliance cables with 1/2" conduit connectors
	TFX24...	3 ft [1m], 10 ft [3m], or 16 ft [5m], 18 GA appliance or plenum cables, with or without 1/2" conduit connector -S models: two 3 ft [1m], 10 ft [3m] or 16 ft [5m] appliance cables with or without 1/2" conduit connectors
Overload protection		electronic throughout 0 to 95° rotation
Angle of rotation		max 95°, adjust. with mechanical stop
Torque		22 in-lbs [2.5 Nm] minimum
Direction of rotation		reversible with cw/ccw mounting
Position indication		visual indicator, 0° to 95° (0° spring return position)
Running time (nominal)	motor	< 75 sec
	spring	< 25 sec @-4°F to 122°F [-20°C to 50°C] < 60 sec @-22°F [-30°C]
Humidity		5 to 95% RH non-condensing
Ambient temperature		-22°F to 122°F [-30°C to 50°C]
Storage temperature		-40°F to 176°F [-40°C to 80°C]
Housing		NEMA type 2 / IP42, UL enclosure type 2
Housing material		UL94-5VA
Agency listings†		cULus acc. to UL60730-1A/-2-14, CAN/CSA E60730-1:02, CE acc. to 2004/108/EC (and 2006/95/EC for -S versions)
Noise level (max)	running	< 50 db (A)
	spring return	62 db (A)
Servicing		maintenance free
Quality standard		ISO 9001
Weight		1.4 lbs (0.6 kg), 1.5 lbs (0.7 kg) with switch
† Rated Impulse Voltage 800V, Type of action 1.AA (1.AA.B for -S version), Control Pollution Degree 3.		
TFB24-S, TFX24-S		
Auxiliary switch		1 x SPDT 3A (0.5A) @ 250 VAC, UL approved adjustable 0° to 95°

Torque min. 22 in-lbs, for control of air dampers

Application

For on/off, fail-safe control of dampers in HVAC systems. Actuator sizing should be done in accordance with the damper manufacturer's specifications. Control is on/off from an auxiliary contact, or a manual switch.

The actuator is mounted directly to a damper shaft from 1/4" up to 1/2" in diameter by means of its universal clamp, 1/2" shaft centered at delivery. A crank arm and several mounting brackets are available for applications where the actuator cannot be direct coupled to the damper shaft.

Operation

The TF series actuators provide true spring return operation for reliable fail-safe application and positive close off on air tight dampers. The spring return system provides consistent torque to the damper with, and without, power applied to the actuator.

The TF series provides 95° of rotation and is provided with a graduated position indicator showing 0° to 90°.

The actuator may be stalled anywhere in its normal rotation without the need of mechanical end switches. Power consumption is reduced in holding mode.

The TF-S versions are provided with one built-in auxiliary switch. This SPDT switch is provided for safety interfacing or signaling, for example, for fan start-up. The switching function is adjustable between 0° and 95°.

SAFETY NOTE

Screw a conduit fitting into the actuator's bushing. Jacket the actuator's input and output wiring with suitable flexible conduit. Properly terminate the conduit in a suitable junction box.

Dimensions (Inches [mm])

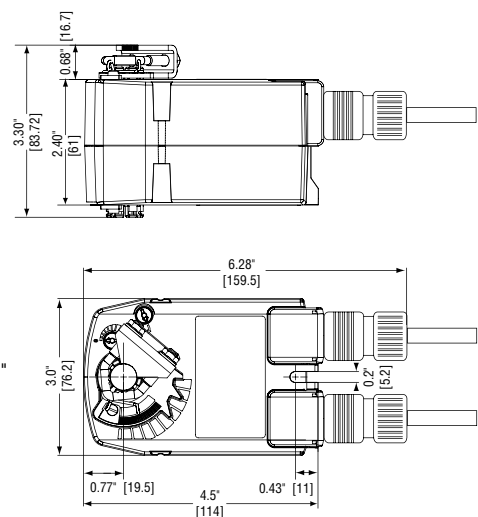

Standard:

- ⊙ 1/4" to 1/2"
- 1/4" to 5/16"

M40103 - 09/11 - Subject to change. © Belimo Aircontrols (USA), Inc.

Accessories

Tool-06	8mm and 10 mm wrench
KH-TF	Crank arm for up to 1/2" round shaft
ZG-TF2	Crank arm adaptor kit for TF
ZG-TF112	Mounting bracket, kit for TF
ZS-100	Weather shield (metal)
ZS-150	Weather shield (polycarbonate)

NOTE: When using TFB24(-S), TFX24(-S) actuators, only use accessories listed on this page. For actuator wiring information and diagrams, please see Belimo wiring guide.

Typical Specification

On/Off spring return damper actuators shall be direct coupled type which require no crank arm and linkage and be capable of direct mounting to a shaft up to a 1/2" diameter and center a 1/2" shaft. The actuators must be designed so that they may be used for either clockwise or counterclockwise fail-safe operation. Actuators shall be protected from overload at all angles of rotation. If required, one SPDT auxiliary switch shall be provided having the capability of being adjustable. Actuators with auxiliary switch must be constructed to meet the requirements for Double Insulation so an electrical ground is not required to meet agency listings. Actuators shall be cULus listed certified, have a 5 year warranty, and be manufactured under ISO 9001 International Quality Control Standards. Actuators shall be as manufactured by Belimo.

Wiring Diagrams
INSTALLATION NOTES

- 1 Provide overload protection and disconnect as required.
- 2 **CAUTION Equipment Damage!**
Actuators may be connected in parallel. Power consumption must be observed.
- 3 Actuators may also be powered by 24 VDC.
- 4 For end position indication, interlock control, fan startup, etc., TFB24-S, TFX24-S incorporates a built-in auxiliary switch: 1 x SPDT, 3A (0.5A) @250 VAC, UL Approved, adjustable 0 to 95.

APPLICATION NOTES

- ◆ Meets cULus requirements without the need of an electrical ground connection.

WARNING Live Electrical Components!

During installation, testing, servicing and troubleshooting of this product, it may be necessary to work with live electrical components. Have a qualified licensed electrician or other individual who has been properly trained in handling live electrical components perform these tasks. Failure to follow all electrical safety precautions when exposed to live electrical components could result in death or serious injury.

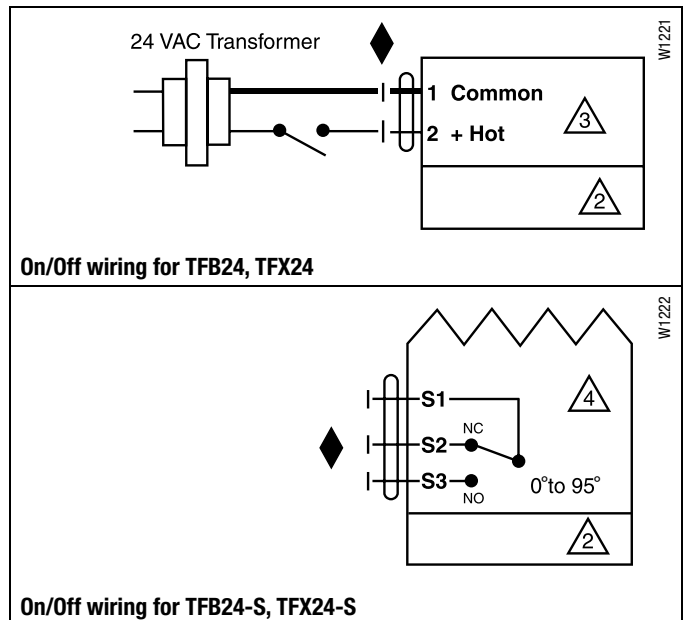

TFLB24

On/Off, Spring Return, 24 V



Technical Data		TFLB24
Power supply		24VAC ± 20%, 50/60Hz 24VDC ± 10%
Power consumption	running	2 W
	holding	1.3 W
Transformer sizing		5 VA (class 2 power source)
Electrical connection		3 ft, 18 GA appliance cable (-S models have 2 cables)
Overload protection		electronic throughout 0 to 95° rotation
Angle of rotation		max 95°, adjust. with mechanical stop
Torque		22 in-lbs [2.5 Nm] minimum
Direction of rotation		reversible with cw/ccw mounting
Position indication		visual indicator, 0° to 95° (0° spring return position)
Running time (nominal)	motor	< 75 sec
	spring	< 75 sec @ -4°F to 122°F [-20°C to 50°C]
Humidity		5 to 95% RH non-condensing
Ambient temperature		-22°F to 122°F [-30°C to 50°C]
Storage temperature		-40°F to 176°F [-40°C to 80°C]
Housing		NEMA type 2 / IP42, UL enclosure type 2
Housing material		UL94-5VA
Agency listings†		cULus acc. to UL60730-1A/-2-14, CAN/CSA E60730-1:02, CE acc. to 2004/108/EC (and 2006/95/EC for -S versions)
Noise level (max)	running	< 40 dB(A)
	spring return	< 40 dB(A)
Servicing		maintenance free
Quality standard		ISO 9001
Weight		1.4 lbs (0.6 kg)

† Rated Impulse Voltage 800V, Type of action 1.AA, Control Pollution Degree 3.

Torque min. 22 in-lbs, for control of air dampers

Application

For on/off, fail-safe control of dampers in HVAC systems. Actuator sizing should be done in accordance with the damper manufacturer's specifications. Control is on/off from an auxiliary contact, or a manual switch.

The actuator is mounted directly to a damper shaft from 1/4" up to 1/2" in diameter by means of its universal clamp, 1/2" shaft centered at delivery. A crank arm and several mounting brackets are available for applications where the actuator cannot be direct coupled to the damper shaft.

Operation

The TF series actuators provide true spring return operation for reliable fail-safe application and positive close off on air tight dampers. The spring return system provides consistent torque to the damper with, and without, power applied to the actuator.

The TF series provides 95° of rotation and is provided with a graduated position indicator showing 0° to 90°.

The actuator may be stalled anywhere in its normal rotation without the need of mechanical end switches. Power consumption is reduced in holding mode.

SAFETY NOTE

Screw a conduit fitting into the actuator's bushing. Jacket the actuator's input and output wiring with suitable flexible conduit. Properly terminate the conduit in a suitable junction box.

Dimensions (Inches [mm])

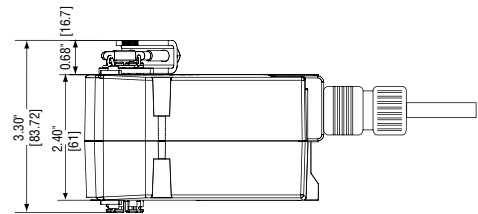

Standard:

- 1/4" to 1/2"
- 1/4" to 5/16"

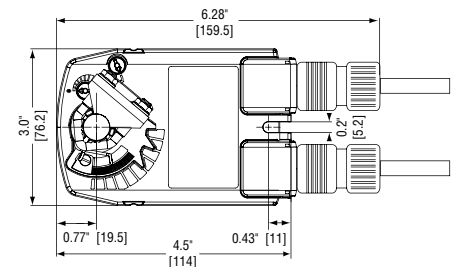

M40103 - 09/11 - Subject to change. © Belimo Aircontrols (USA), Inc.

Accessories

Tool-06	8mm and 10 mm wrench
KH-TF	Crank arm for up to 1/2" round shaft
ZG-TF2	Crank arm adaptor kit for TF
ZG-TF112	Mounting bracket, kit for TF
ZS-100	Weather shield (metal)
ZS-150	Weather shield (polycarbonate)

NOTE: When using TFLB24 actuators, only use accessories listed on this page.
For actuator wiring information and diagrams, Please See Belimo wiring guide.

Typical Specification

On/Off spring return damper actuators shall be direct coupled type which require no crank arm and linkage and be capable of direct mounting to a shaft up to a 1/2" diameter and center a 1/2" shaft. The actuators must be designed so that they may be used for either clockwise or counterclockwise fail-safe operation. Actuators shall be protected from overload at all angles of rotation. Actuators with auxiliary switch must be constructed to meet the requirements for Double Insulation so an electrical ground is not required to meet agency listings. Actuators shall be cULus listed certified, have a 5 year warranty, and be manufactured under ISO 9001 International Quality Control Standards. Actuators shall be as manufactured by Belimo.

Wiring Diagrams

INSTALLATION NOTES

- Provide overload protection and disconnect as required.
- CAUTION Equipment Damage!**
Actuators may be connected in parallel.
Power consumption must be observed.
- Actuators may also be powered by 24 VDC.

APPLICATION NOTES

Meets cULus requirements without the need of an electrical ground connection.

WARNING Live Electrical Components!
During installation, testing, servicing and troubleshooting of this product, it may be necessary to work with live electrical components. Have a qualified licensed electrician or other individual who has been properly trained in handling live electrical components perform these tasks. Failure to follow all electrical safety precautions when exposed to live electrical components could result in death or serious injury.

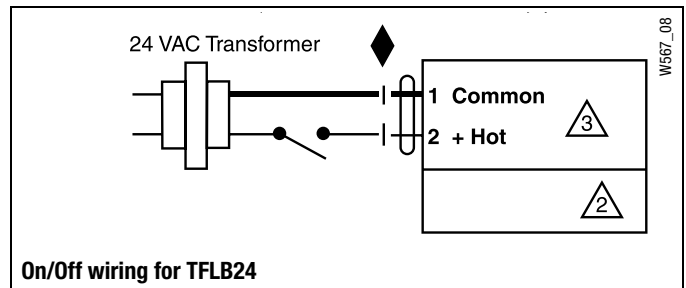

TFB120(-S), TFX120(-S)

On/Off, Spring Return, 100 to 240 VAC



Technical Data		TFB120(-S), TFX120(-S)
Power supply	nominal	100 to 240 VAC, 50/60 Hz
	tolerance	85 to 265 VAC, 50/60 Hz
Power consumption	running	2.5 W
	holding	1.3 W
Transformer sizing		5 VA (class 2 power source)
Electrical connection TFB120...		3 ft, 18 GA appliance cable, 1/2" conduit connector
		-S models: two 3 ft, 18 gauge appliance cables with 1/2" conduit connectors
TFX120...		3 ft [1m], 10 ft [3m], or 16 ft [5m], 18 GA appliance cable, with or without 1/2" conduit connector
		-S models: two 3 ft [1m], 10 ft [3m] or 16 ft [5m] appliance cables with or without 1/2" conduit connectors
Overload protection		electronic throughout 0 to 95° rotation
Electrical protection		actuators are double insulated
Angle of rotation		max 95°, adjust. with mechanical stop
Torque		22 in-lbs [2.5 Nm] minimum
Direction of rotation		reversible with cw/ccw mounting
Position indication		visual indicator, 0° to 95° (0° spring return position)
Running time	motor	< 75 sec
	spring	< 25 sec @-4°F to 122°F [-20°C to 50°C] < 60 sec @-22°F [-30°C]
Humidity		5 to 95% RH non-condensing
Ambient temperature		-22°F to 122°F [-30°C to 50°C]
Storage temperature		-40°F to 176°F [-40°C to 80°C]
Housing		NEMA type 2 / IP42, UL enclosure type 2
Housing material		UL94-5VA
Agency listings†		cULus acc. to UL60730-1A/-2-14, CAN/CSA E60730-1:02, CE acc. to 2004/108/EC (and 2006/95/EC for -S versions)
Noise level (max)	running	< 50 db (A)
	spring return	62 dB (A)
Servicing		maintenance free
Quality standard		ISO 9001
Weight		1.4 lbs (0.6 kg), 1.5 lbs (0.7 kg) with switch

† Rated Impulse Voltage 4kV, Type of action 1.AA (1.AA.B for -S version), Control Pollution Degree 3.

TFB120-S, TFX120-S	
Auxiliary switch	1 x SPDT 3A (0.5A) @ 250 VAC, UL approved adjustable 0° to 95°

Torque min. 22 in-lbs, for control of air dampers

Application

For on/off, fail-safe control of dampers in HVAC systems. Actuator sizing should be done in accordance with the damper manufacturer's specifications. Control is on/off from an auxiliary contact, or a manual switch.

The actuator is mounted directly to a damper shaft from 1/4" up to 1/2" in diameter by means of its universal clamp, 1/2" shaft centered at delivery. A crank arm and several mounting brackets are available for applications where the actuator cannot be direct coupled to the damper shaft.

Operation

The TF series actuators provide true spring return operation for reliable fail-safe application and positive close off on air tight dampers. The spring return system provides consistent torque to the damper with, and without, power applied to the actuator.

The TF series provides 95° of rotation and is provided with a graduated position indicator showing 0° to 90°.

The actuator may be stalled anywhere in its normal rotation without the need of mechanical end switches. Power consumption is reduced in holding mode. The actuator is double insulated so an electrical ground connection is not necessary.

The TF-S versions are provided with one built-in auxiliary switch. This SPDT switch is provided for safety interfacing or signaling, for example, for fan start-up. The switching function is adjustable between 0° and 95°.

SAFETY NOTE

Screw a conduit fitting into the actuator's bushing. Jacket the actuator's input and output wiring with suitable flexible conduit. Properly terminate the conduit in a suitable junction box.

Dimensions (Inches [mm])

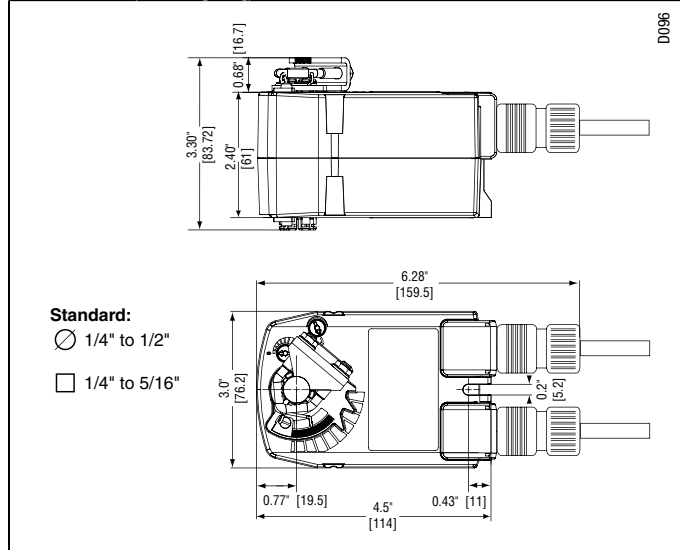

M40103 - 09/11 - Subject to change. © Belimo Aircontrols (USA), Inc.

Accessories

Tool-06	8mm and 10 mm wrench
KH-TF	Crank arm for up to 1/2" round shaft
ZG-TF2	Crank arm adaptor kit for TF
ZG-TF112	Mounting bracket, kit for TF
ZS-100	Weather shield (metal)
ZS-150	Weather shield (polycarbonate)

NOTE: When using TFB120(-S) and TFX120(-S) actuators, only use accessories listed on this page. For actuator wiring information and diagrams, refer to Belimo wiring guide.

Typical Specification

On/Off spring return damper actuators shall be direct coupled type which require no crank arm and linkage and be capable of direct mounting to a shaft up to a 1/2" diameter and center a 1/2" shaft. The actuators must be designed so that they may be used for either clockwise or counterclockwise fail-safe operation. Actuators shall be protected from overload at all angles of rotation. If required, one SPDT auxiliary switch shall be provided having the capability of being adjustable. Actuators must be constructed to meet the requirements for Double Insulation so an electrical ground is not required to meet agency listings. Actuators shall be cULus listed and have a 5 year warranty, and be manufactured under ISO 9001 International Quality Control Standards. Actuators shall be as manufactured by Belimo.

Wiring Diagrams

INSTALLATION NOTES

- 1 Provide overload protection and disconnect as required.
- 2 **CAUTION Equipment Damage!** Actuators may be connected in parallel. Power consumption must be observed.
- 4 For end position indication, interlock control, fan startup, etc., TFB120-S, TFX120-S incorporate one built-in auxiliary switch: 1 x SPDT, 3A (0.5A) @250 VAC, UL Approved, adjustable 0° to 95°.

APPLICATION NOTES

Meets cULus requirements without the need of an electrical ground connection.

WARNING Live Electrical Components! During installation, testing, servicing and troubleshooting of this product, it may be necessary to work with live electrical components. Have a qualified licensed electrician or other individual who has been properly trained in handling live electrical components perform these tasks. Failure to follow all electrical safety precautions when exposed to live electrical components could result in death or serious injury.

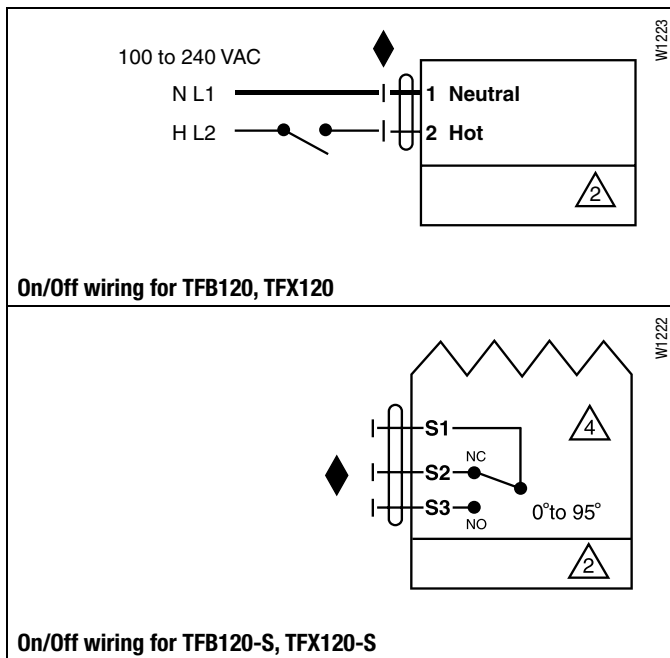

TFLB120

On/Off, Spring Return, 24 V



Technical Data		TFLB120
Power supply	nominal tolerance	100 to 240 VAC, 50/60 Hz 85 to 265 VAC, 50/60 Hz
Power consumption	running holding	2.5 W 1.3 W
Transformer sizing		5 VA (class 2 power source)
Electrical connection		3 ft, 18 GA appliance cable (-S models have 2 cables) 1/2" conduit connector
Overload protection		electronic throughout 0 to 95° rotation
Electrical protection		actuators are double insulated
Angle of rotation		max 95°, adjust. with mechanical stop
Torque		22 in-lbs [2.5 Nm] minimum
Direction of rotation		reversible with cw/ccw mounting
Position indication		visual indicator, 0° to 95° (0° spring return position)
Running time	motor spring	< 75 sec < 75 sec @ -4°F to 122°F [-20°C to 50°C]
Humidity		5 to 95% RH non-condensing
Ambient temperature		-22°F to 122°F [-30°C to 50°C]
Storage temperature		-40°F to 176°F [-40°C to 80°C]
Housing		NEMA type 2 / IP42, UL enclosure type 2
Housing material		UL94-5VA
Agency listings†		cULus acc. to UL60730-1A/-2-14, CAN/CSA E60730-1:02, CE acc. to 2004/108/EC (and 2006/95/EC for -S versions)
Noise level (max)	running spring return	< 40 dB(A) < 40 dB(A)
Servicing		maintenance free
Quality standard		ISO 9001
Weight		1.4 lbs (0.6 kg)

† Rated Impulse Voltage 4kV, Type of action 1.AA, Control Pollution Degree 3.

Torque min. 22 in-lbs, for control of air dampers

Application

For on/off, fail-safe control of dampers in HVAC systems. Actuator sizing should be done in accordance with the damper manufacturer's specifications. Control is on/off from an auxiliary contact, or a manual switch.

The actuator is mounted directly to a damper shaft from 1/4" up to 1/2" in diameter by means of its universal clamp, 1/2" shaft centered at delivery. A crank arm and several mounting brackets are available for applications where the actuator cannot be direct coupled to the damper shaft.

Operation

The TF series actuators provide true spring return operation for reliable fail-safe application and positive close off on air tight dampers. The spring return system provides consistent torque to the damper with, and without, power applied to the actuator.

The TF series provides 95° of rotation and is provided with a graduated position indicator showing 0° to 90°.

The actuator may be stalled anywhere in its normal rotation without the need of mechanical end switches. Power consumption is reduced in holding mode. The actuator is double insulated so an electrical ground connection is not necessary.

SAFETY NOTE

Screw a conduit fitting into the actuator's bushing. Jacket the actuator's input and output wiring with suitable flexible conduit. Properly terminate the conduit in a suitable junction box.

Dimensions (Inches [mm])

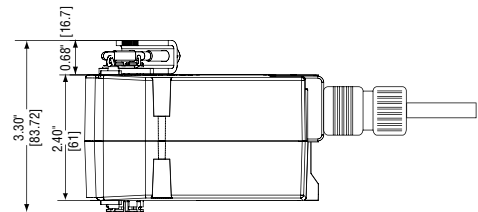

Standard:

- 1/4" to 1/2"
- 1/4" to 5/16"

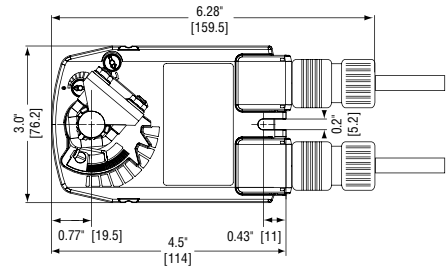

M40103 - 09/11 - Subject to change. © Belimo Aircontrols (USA), Inc.

Accessories

Tool-06	8mm and 10 mm wrench
KH-TF	Crank arm for up to 1/2" round shaft
ZG-TF2	Crank arm adaptor kit for TF
ZG-TF112	Mounting bracket, kit for TF
ZS-100	Weather shield (metal)
ZS-150	Weather shield (polycarbonate)

NOTE: When using TFLB120 actuators, only use accessories listed on this page.
For actuator wiring information and diagrams, refer to Belimo wiring guide.

Typical Specification

On/Off spring return damper actuators shall be direct coupled type which require no crank arm and linkage and be capable of direct mounting to a shaft up to a 1/2" diameter and center a 1/2" shaft. The actuators must be designed so that they may be used for either clockwise or counterclockwise fail-safe operation. Actuators shall be protected from overload at all angles of rotation. Actuators must be constructed to meet the requirements for Double Insulation so an electrical ground is not required to meet agency listings. Actuators shall be cULus listed and have a 5 year warranty, and be manufactured under ISO 9001 International Quality Control Standards. Actuators shall be as manufactured by Belimo.

Wiring Diagrams

✂ **INSTALLATION NOTES**

⚠ 2 CAUTION Equipment Damage!
Actuators may be connected in parallel.
Power consumption must be observed.

📄 **APPLICATION NOTES**

◆ Meets cULus requirements without the need of an electrical ground connection.

⚠ WARNING Live Electrical Components!
During installation, testing, servicing and troubleshooting of this product, it may be necessary to work with live electrical components. Have a qualified licensed electrician or other individual who has been properly trained in handling live electrical components perform these tasks. Failure to follow all electrical safety precautions when exposed to live electrical components could result in death or serious injury.

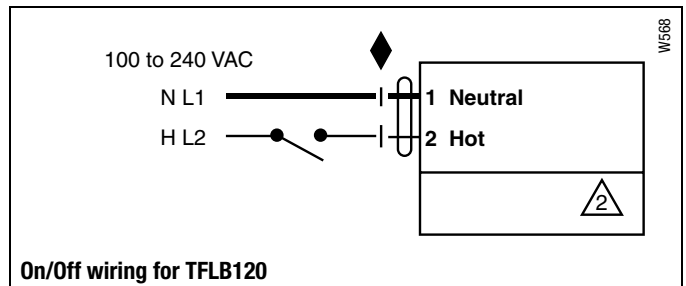

TFCB120-S, TFCX120-S

On/Off, Spring Return, 100-240 VAC



Technical Data		TFCB120-S, TFCX120-S
Power supply	nominal	100 to 240 VAC, 50/60 Hz
	tolerance	85 to 265 VAC, 50/60 Hz
Power consumption	running	3 W
	holding	1.5 W
Transformer sizing		6 VA (class 2 power source)
Electrical connection		two 3 ft, 18 gauge appliance cables with 1/2" conduit connectors
	TFCX120...	two 3 ft [1m], 10 ft [3m] or 16 ft [5m] appliance cables with or without 1/2" conduit connectors
Overload protection		electronic throughout 0 to 95° rotation
Electrical protection		actuators are double insulated
Angle of rotation		max 95°, adjust. with mechanical stop
Torque		22 in-lbs [2.5 Nm] minimum
Direction of rotation		reversible with cw/ccw mounting
Position indication		visual indicator, 0° to 95° (0° spring return position)
Auxiliary switch		1 x SPDT 3A (0.5A) @ 250 VAC, UL approved adjustable 0° to 95°
Running time	motor	< 30 sec
	spring	< 25 sec @ -4°F to 122°F [-20°C to 50°C] < 60 sec @ -22°F [-30°C]
Humidity		5 to 95% RH non-condensing
Ambient temperature		-22°F to 122°F [-30°C to 50°C]
Storage temperature		-40°F to 176°F [-40°C to 80°C]
Housing		NEMA type 2 / IP42, UL enclosure type 2
Housing material		UL94-5VA
Agency listings†		cULus acc. to UL60730-1A/-2-14, CAN/CSA E60730-1:02, CE acc. to 2004/108/EC, and 2006/95/EC
Noise level (max)	running	< 56 db (A)
	spring return	63 db (A)
Servicing		maintenance free
Quality standard		ISO 9001
Weight		1.5 lbs (0.7 kg)

† Rated Impulse Voltage 4kV, Type of action 1.AA.B, Control Pollution Degree 3.

Torque min. 22 in-lbs, for control of air dampers

Application

For on/off fast running, fail-safe control of dampers in HVAC systems. Actuator sizing should be done in accordance with the damper manufacturer's specifications. Control is on/off from an auxiliary contact, or a manual switch.

The actuator is mounted directly to a damper shaft from 1/4" up to 1/2" in diameter by means of its universal clamp, 1/2" shaft centered at delivery. A crank arm and several mounting brackets are available for applications where the actuator cannot be direct coupled to the damper shaft.

Operation

The TF series actuators provide true spring return operation for reliable fail-safe application and positive close off on air tight dampers. The spring return system provides consistent torque to the damper with, and without, power applied to the actuator.

The TF series provides 95° of rotation and is provided with a graduated position indicator showing 0° to 90°.

The actuator may be stalled anywhere in its normal rotation without the need of mechanical end switches. Power consumption is reduced in holding mode. The actuator is double insulated so an electrical ground connection is not necessary.

The TFCB120-S version is provided with one built-in auxiliary switch. This SPDT switch is provided for safety interfacing or signaling, for example, for fan start-up. The switching function is adjustable between 0° and 95°.

SAFETY NOTE

Screw a conduit fitting into the actuator's bushing. Jacket the actuator's input and output wiring with suitable flexible conduit. Properly terminate the conduit in a suitable junction box.

Dimensions (Inches [mm])

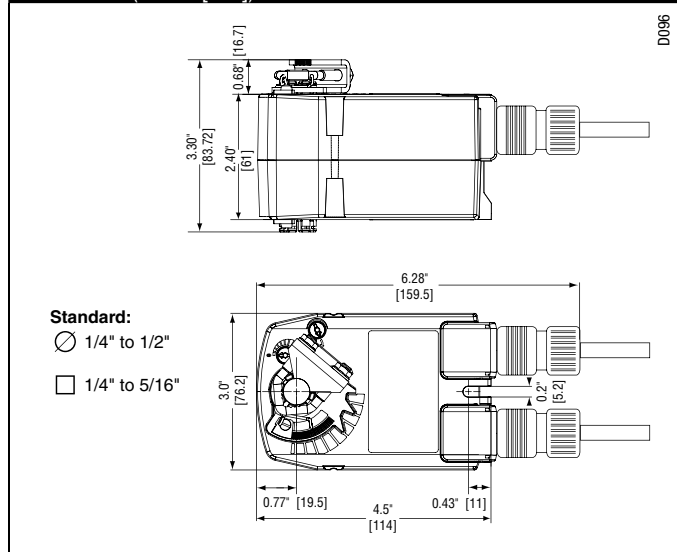

M40103 - 09/11 - Subject to change. © Belimo Aircontrols (USA), Inc.

Accessories	
Tool-06	8mm and 10 mm wrench
KH-TF	Crank arm for up to 1/2" round shaft
ZG-TF2	Crank arm adaptor kit for TF
ZG-TF112	Mounting bracket, kit for TF
ZG-TF113	Mounting bracket, kit for TF
ZS-100	Weather shield (metal)
ZS-150	Weather shield (polycarbonate)

NOTE: When using TFCB120-S, TFCX120-S actuators, only use accessories listed on this page.
For actuator wiring information and diagrams, refer to Belimo wiring guide.

Typical Specification

On/Off spring return damper actuators shall be direct coupled type which require no crank arm and linkage and be capable of direct mounting to a shaft up to a 1/2" diameter and center a 1/2" shaft. The actuators must be designed so that they may be used for either clockwise or counterclockwise fail-safe operation. Actuators shall be protected from overload at all angles of rotation. If required, one SPDT auxiliary switch shall be provided having the capability of being adjustable. Actuators must be constructed to meet the requirements for Double Insulation so an electrical ground is not required to meet agency listings. Actuators shall be cULus listed and have a 5 year warranty, and be manufactured under ISO 9001 International Quality Control Standards. Actuators shall be as manufactured by Belimo.

Wiring Diagram

✂️ INSTALLATION NOTES

- 1 Provide overload protection and disconnect as required.
- 2 **CAUTION Equipment Damage!**
Actuators may be connected in parallel. Power consumption must be observed.
- 4 For end position indication, interlock control, fan startup, etc., TFCB120-S, TFCX120-S incorporate one built-in auxiliary switch: 1 x SPDT, 3A (0.5A) @250 VAC, UL Approved, adjustable 0° to 95°.

📄 APPLICATION NOTES

◆ Meets cULus requirements without the need of an electrical ground connection.

⚠️ **WARNING Live Electrical Components!**
During installation, testing, servicing and troubleshooting of this product, it may be necessary to work with live electrical components. Have a qualified licensed electrician or other individual who has been properly trained in handling live electrical components perform these tasks. Failure to follow all electrical safety precautions when exposed to live electrical components could result in death or serious injury.

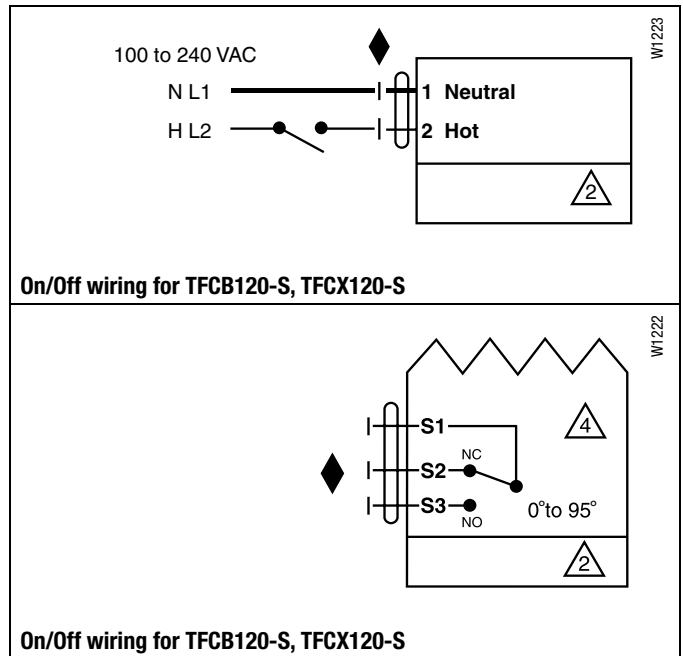

TFB24-3(-S), TFX24-3(-S)

On/Off, Floating Point, Spring Return, 24V



Technical Data		TFB24-3(-S), TFX24-3(-S)
Power supply		24 VAC ± 20%, 50/60 Hz
Power consumption	running	2.5 W
	holding	1 W
Transformer sizing		4 VA (class 2 power source)
Electrical connection		
TFB...		3 ft, 18 GA plenum cable, 1/2" conduit connector -S models: two 3 ft, 18 gauge appliance cables with 1/2" conduit connectors
TFX...		3 ft [1m], 10 ft [3m], or 16 ft [5m], 18 GA appliance or plenum cable, with or without 1/2" conduit connector -S models: two 3 ft [1m], 10 ft [3m] or 16 ft [5m] appliance cables with or without 1/2" conduit connectors
Overload protection		electronic throughout 0 to 95° rotation
Input impedance		1000 Ω (0.6w) control inputs
Electrical protection		actuators are double insulated
Angle of rotation		max 95°, adjust. with mechanical stop
Torque		22 in-lbs [2.5 Nm] minimum
Direction of rotation	spring motor	reversible with cw/ccw mounting reversible with built-in switch
Position indication		visual indicator, 0° to 95° (0° spring return position)
Running time	motor spring	95 sec constant, independent of load < 25 sec @ -4°F to 122°F [-20°C to 50°C] < 60 sec @ -22°F [-30°C]
Humidity		5 to 95% RH non-condensing
Ambient temperature		-22°F to 122°F [-30°C to 50°C]
Storage temperature		-40°F to 176°F [-40°C to 80°C]
Housing		NEMA type 2 / IP42, UL enclosure type 2
Housing material		UL94-5VA
Agency listings†		cULus acc. to UL60730-1A/-2-14, CAN/CSA E60730-1:02, CE acc. to 2004/108/EC, (and 2006/95/EC for -S versions)
Noise level (max)	running spring return	< 35 db (A) 62 dB (A)
Servicing		maintenance free
Quality standard		ISO 9001
Weight		1.4 lbs (0.6 kg), 1.5 lbs (0.5 kg) with switch
†Rated Impulse Voltage 800V, Type of action 1.AA (1.AA.B for -S version), Control Pollution Degree 3.		
TFB24-3-S, TFX24-3-S		
Auxiliary switch		1 x SPDT 3A (0.5A) @ 250 VAC, UL approved adjustable 0° to 95° (double insulated)

Torque min. 22 in-lbs, for control of air dampers

Application

For modulation or on/off control of dampers in HVAC systems. Actuator sizing should be done in accordance with the damper manufacturer's specifications.

The actuator is mounted directly to a damper shaft from 1/4" up to 1/2" in diameter by means of its universal clamp, 1/2" shaft centered at delivery. A crank arm and several mounting brackets are available for applications where the actuator cannot be direct coupled to the damper shaft.

Control is floating point from a triac or relay, or on/off from an auxiliary contact on a fan motor contactor, controller, or manual switch.

Operation

The TF series actuators provide true spring return operation for reliable fail-safe application and positive close-off on air tight dampers. The spring return system provides consistent torque to the damper with, and without, power applied to the actuator.

The TF series provides 95° of rotation and is provided with a graduated position indicator showing 0 to 95°.

The TF uses a brushless DC motor which is controlled by an Application Specific Integrated Circuit (ASIC) and a microprocessor. The microprocessor provides the intelligence to the ASIC to provide a constant rotation rate. The ASIC monitors and controls the brushless DC motor's rotation and provides a digital rotation sensing function to prevent damage to the actuator in a stall condition. The actuator may be stalled anywhere in its normal rotation without the need of mechanical end switches.

Power consumption is reduced in holding mode.

The TF-S version is provided with one built-in auxiliary switch. This SPDT switch is provided for safety interfacing or signaling, for example, for fan start-up. The switching function is adjustable between 0° and 95°. The auxiliary switch in the TF-S is double insulated so an electrical ground is not necessary.

SAFETY NOTE

Screw a conduit fitting into the actuator's bushing. Jacket the actuator's input and output wiring with suitable flexible conduit. Properly terminate the conduit in a suitable junction box.

Dimensions (Inches [mm])

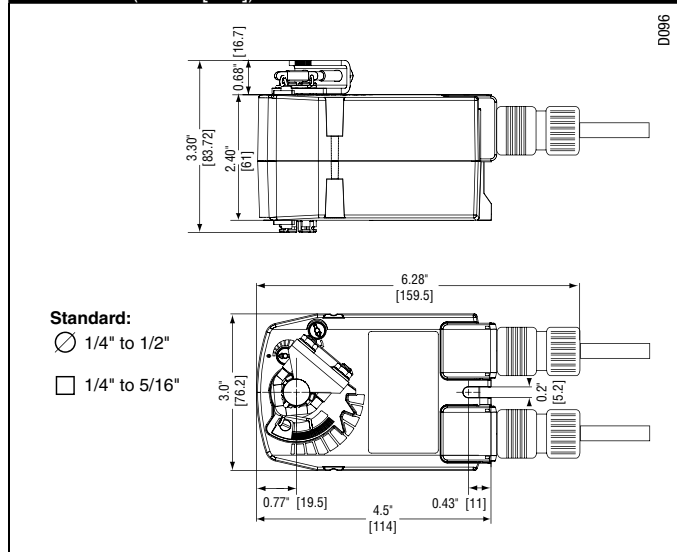

M40103 - 09/11 - Subject to change. © Belimo Aircontrols (USA), Inc.

Accessories

Tool-06	8mm and 10 mm wrench
KH-TF	Crank arm for up to 1/2" round shaft
ZG-TF2	Crank arm adaptor kit for TF
ZG-TF112	Mounting bracket, kit for TF
ZS-100	Weather shield (metal)
ZS-150	Weather shield (polycarbonate)

NOTE: When using TFB24-3(-S), TFX24-3(-S) actuators, only use accessories listed on this page.
For actuator wiring information and diagrams, refer to Belimo wiring guide.

Typical Specification

Floating point, On/Off spring return damper actuators shall be direct coupled type which require no crank arm and linkage and be capable of direct mounting to a shaft up to a 1/2" diameter and center a 1/2" shaft. The actuators must be designed so that they may be used for either clockwise or counterclockwise fail-safe operation. Actuators shall have an external direction of rotation switch to reverse control logic. Actuators shall use a brushless DC motor and be protected from overload at all angles of rotation. If required, one SPDT auxiliary switch shall be provided having the capability of being adjustable. Actuators with auxiliary switch must be constructed to meet the requirements for Double Insulation so an electrical ground is not required to meet agency listings. Run time shall be constant and independent of torque. Actuators shall be cULus listed certified, have a 5 year warranty, and be manufactured under ISO 9001 International Quality Control Standards. Actuators shall be as manufactured by Belimo.

Wiring Diagrams

INSTALLATION NOTES

- 2 CAUTION Equipment Damage!**
Actuators may be connected in parallel. Power consumption must be observed.
- 3** The Common connection from the actuator must be connected to the Hot connection of the controller.
- 4** The actuator Hot must be connected to the control board Common.
- 5** For end position indication, interlock control, fan startup, etc., TFB24-3-S, TFX24-3-S incorporates one built-in auxiliary switch: 1 x SPDT, 3A (0.5A) @250 VAC, UL Approved, adjustable 0° to 95°.
- 7** Actuators with plenum rated cable do not have numbers on wires; use color coded instead. Actuators with appliance rated cable use numbers. TF-S has an Orange wire #5 instead of #4.

APPLICATION NOTES

- Meets cULus requirements without the need of an electrical ground connection.

WARNING Live Electrical Components!
During installation, testing, servicing and troubleshooting of this product, it may be necessary to work with live electrical components. Have a qualified licensed electrician or other individual who has been properly trained in handling live electrical components perform these tasks. Failure to follow all electrical safety precautions when exposed to live electrical components could result in death or serious injury.

M40103 - 09/11 - Subject to change. © Belimo Aircontrols (USA), Inc.

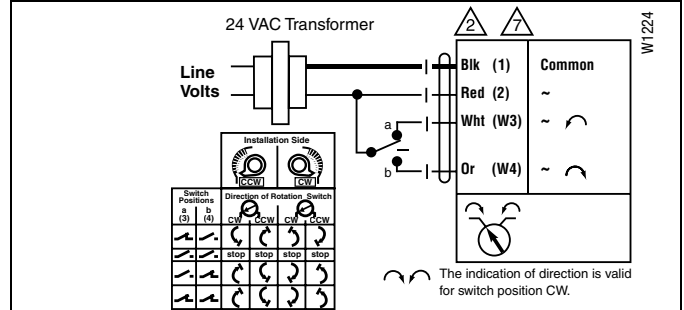

Floating Point control for TFB24-3(-S), TFX24-3(-S)

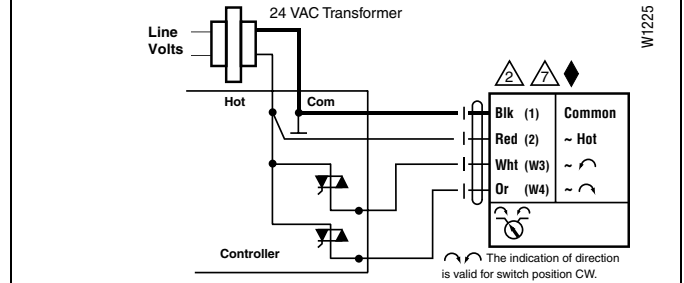

Triac source

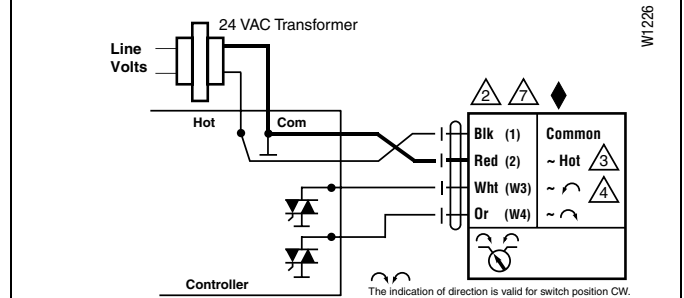

Triac sink

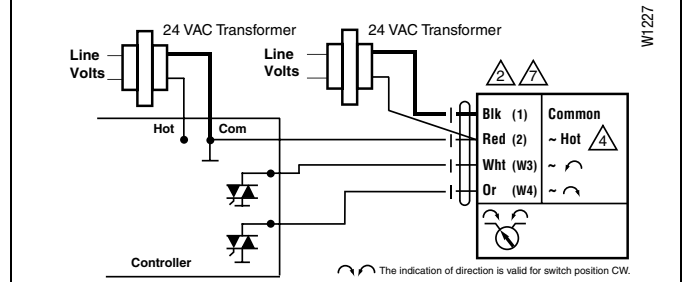

Triac sink with separate transformers

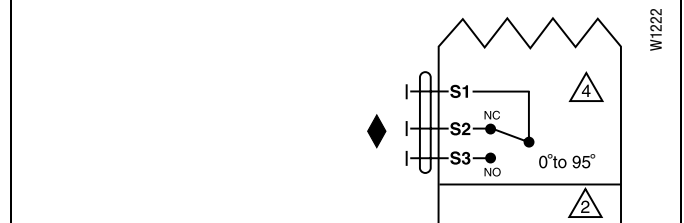

Auxiliary switch of TFB24-3(-S), TFX24-3(-S)

TFB24-SR(-S), TFX24-SR(-S)

Proportional, Spring Return, 24 V, for 2 to 10 VDC or 4 to 20 mA Control Signal



Technical Data		TFB24-SR(-S), TFX24-SR(-S)
Power supply		24 VAC ± 20% 50/60 Hz 24 VDC ± 10%
Power consumption	running	2 W
	holding	1 W
Transformer sizing		4 VA (class 2 power source)
Electrical connection TFB...		3 ft, 18 GA plenum cable, 1/2" conduit connector -S models: two 3 ft, 18 gauge appliance cables with 1/2" conduit connectors
	TFX	3 ft [1m], 10 ft [3m], or 16 ft [5m], 18 GA appliance or plenum cable, with or without 1/2" conduit connector -S models: two 3 ft [1m], 10 ft [3m] or 16 ft [5m] appliance cables with or without 1/2" conduit connectors
Overload protection		electronic throughout 0 to 95° rotation
Operating range Y		2 to 10 VDC, 4 to 20mA
Input impedance		100 kΩ (0.1 mA), 500 Ω
Feedback output U		2 to 10 VDC, 0.5 mA max
Angle of rotation		max 95°, adjust. with mechanical stop
Torque		22 in-lbs [2.5 Nm]
Direction of rotation	spring	reversible with cw/ccw mounting
	motor	reversible with built-in switch
Position indication		visual indicator, 0° to 95° (0° spring return position)
Running time	motor	95 sec constant, independent of load
	spring	< 25 sec @ -4°F to 122°F [-20°C to 50°C] < 60 sec @ -22°F [-30°C]
Humidity		5 to 95% RH non-condensing
Ambient temperature		-22°F to 122°F [-30°C to 50°C]
Storage temperature		-40°F to 176°F [-40°C to 80°C]
Housing		NEMA type 2 / IP42, UL enclosure type 2
Housing material		UL94-5VA
Agency listings†		cULus acc. to UL60730-1A/-2-14, CAN/CSA E60730-1:02, CE acc. to 2004/108/EC (and 2006/95/EC for -S versions)
Noise level (max)	running	< 35 db (A)
	spring return	62 db (A)
Servicing		maintenance free
Quality standard		ISO 9001
Weight		1.4 lbs (0.6 kg), 1.5 lbs (0.7 kg) with switch

TFB24-SR-S, TFX24-SR-S	
Auxiliary switch	1 x SPDT 3A (0.5A) @ 250 VAC, UL approved adjustable 0° to 95° (double insulated)

Torque min. 22 in-lbs, for control of air dampers

Application

For proportional modulation of dampers in HVAC systems. Actuator sizing should be done in accordance with the damper manufacturer's specifications.

The actuator is mounted directly to a damper shaft from 1/4" up to 1/2" in diameter by means of its universal clamp, 1/2" shaft centered at delivery. A crank arm and several mounting brackets are available for applications where the actuator cannot be direct coupled to the damper shaft.

The actuator operates in response to a 2 to 10 VDC, or with the addition of a 500 Ω resistor, a 4 to 20 mA control input from an electronic controller or positioner.

Operation

The TF series actuators provide true spring return operation for reliable fail-safe application and positive close-off on air tight dampers. The spring return system provides consistent torque to the damper with, and without, power applied to the actuator.

The TF series provides 95° of rotation and is provided with a graduated position indicator showing 0 to 95°.

The TF uses a brushless DC motor which is controlled by an Application Specific Integrated Circuit (ASIC) and a microprocessor. The microprocessor provides the intelligence to the ASIC to provide a constant rotation rate and to know the actuator's exact fail-safe position. The ASIC monitors and controls the brushless DC motor's rotation and provides a digital rotation sensing function to prevent damage to the actuator in a stall condition. The actuator may be stalled anywhere in its normal rotation without the need of mechanical end switches. Power consumption is reduced in holding mode.

The TF-S version is provided with one built-in auxiliary switch. This SPDT switch is provided for safety interfacing or signaling, for example, for fan start-up. The switching function is adjustable between 0° and 95°. The auxiliary switch in the TF-S is double insulated so an electrical ground is not necessary.

SAFETY NOTE

Screw a conduit fitting into the actuator's bushing. Jacket the actuator's input and output wiring with suitable flexible conduit. Properly terminate the conduit in a suitable junction box.

Dimensions (Inches [mm])

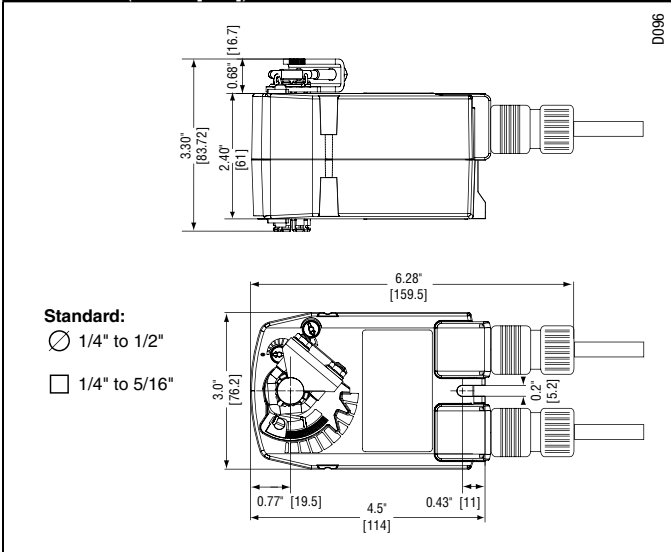

M40103 - 09/11 - Subject to change. © Belimo Aircontrols (USA), Inc.

Accessories

Tool-06	8mm and 10 mm wrench
KH-TF	Crank arm for up to 1/2" round shaft
ZG-TF2	Crank arm adaptor kit for TF
ZG-TF112	Mounting bracket, kit for TF
ZS-100	Weather shield (metal)
ZS-150	Weather shield (polycarbonate)

NOTE: When using TFB24-SR (-S), TFX24-SR (-S) actuators, only use accessories listed on this page. For actuator wiring information and diagrams, refer to Belimo wiring guide.

Typical Specification

Spring return control damper actuators shall be direct coupled type which require no crank arm and linkage and be capable of direct mounting to a shaft up to a 1/2" diameter and center a 1/2" shaft. The actuator must provide proportional damper control in response to a 2 to 10 VDC or, with the addition of a 500 Ω resistor, a 4 to 20 mA control input from an electronic controller or positioner. The actuators must be designed so that they may be used for either clockwise or counterclockwise fail-safe operation. Actuators shall use a brushless DC motor controlled by a microprocessor and be protected from overload at all angles of rotation. Run time shall be constant, and independent of torque. If required, one SPDT auxiliary switch shall be provided having the capability of being adjustable. Actuators with auxiliary switch must be constructed to meet the requirements for Double Insulation so an electrical ground is not required to meet agency listings. Actuators shall be cULus listed certified, have a 5 year warranty, and be manufactured under ISO 9001 International Quality Control Standards. Actuators shall be as manufactured by Belimo.

Wiring Diagrams

INSTALLATION NOTES

- CAUTION Equipment Damage!**
Up to 4 actuators may be connected in parallel. With 4 actuators wired to one 500 Ω resistor, a +2% shift of control signal may be required. Power consumption must be observed.
- Actuator may also be powered by 24 VDC.
- Only connect common to neg. (-) leg of control circuits.
- Actuators with plenum rated cable do not have numbers on wires; use color codes instead.
- For end position indication, interlock control, fan startup, etc., TFB24-SR-S, TFX24-SR-S incorporates one built-in auxiliary switch: 1 x SPDT, 3A (0.5 A) @250 VAC, UL Approved, adjustable 0° to 95°.

APPLICATION NOTES

- Meets cULus requirements without the need of an electrical ground connection.
- The ZG-R01 500 Ω resistor converts the 4 to 20 mA control signal to 2 to 10 VDC.

WARNING Live Electrical Components!
 During installation, testing, servicing and troubleshooting of this product, it may be necessary to work with live electrical components. Have a qualified licensed electrician or other individual who has been properly trained in handling live electrical components perform these tasks. Failure to follow all electrical safety precautions when exposed to live electrical components could result in death or serious injury.

M40103 - 09/11 - Subject to change. © Belimo Aircontrols (USA), Inc.

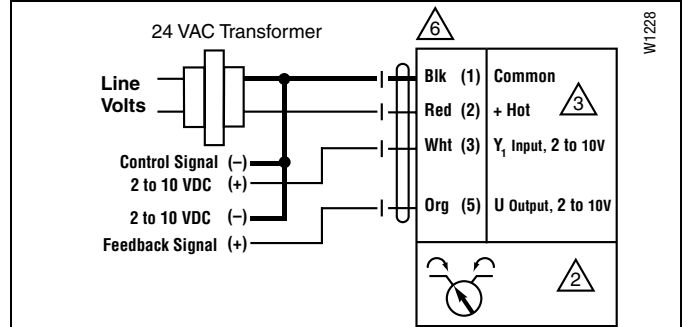

2 to 10 VDC control of TFX24-SR(-S)

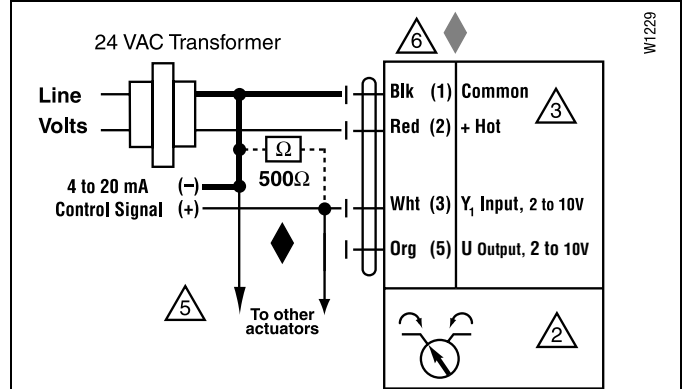

4 to 20 mA control of TFB24-SR(-S), TFX24-SR(-S)

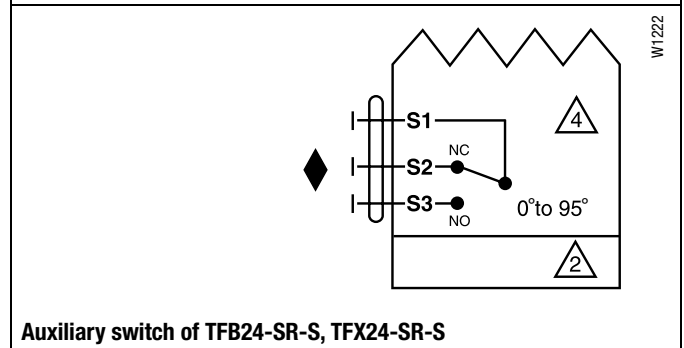

Auxiliary switch of TFB24-SR-S, TFX24-SR-S

TFB120-SR

Proportional, Spring Return, 120 V, for 2 to 10 VDC or 4 to 20 mA Control Signal



Technical Data		TFB120-SR
Power supply		100...240 VAC + 10% / -15%, 50/60 Hz
Power consumption	running	2.5 W
	holding	2 W
Transformer sizing		5.5 VA
Electrical connection		two 3 ft, 18 GA appliance cables 1/2" conduit connectors
Overload protection		electronic throughout 0 to 95° rotation
Operating range Y		2 to 10 VDC, 4 to 20mA
Input impedance		100 kΩ (0.1 mA), 500 Ω
Feedback output U		2 to 10 VDC (max. 0.5 mA) for 95°
Angle of rotation		max 95°, adjust. with mechanical stop
Torque		22 in-lbs [2.5 Nm] minimum
Direction of rotation	spring	reversible with cw/ccw mounting
	motor	reversible with built-in switch
Position indication		visual indicator, 0° to 95° (0° spring return position)
Running time	motor	95 sec constant, independent of load
	spring	< 25 sec @ -4°F to 122°F [-20°C to 50°C] < 60 sec @ -22°F [-30°C]
Humidity		5 to 95% RH non-condensing
Ambient temperature		-22°F to 122°F [-30°C to 50°C]
Storage temperature		-40°F to 176°F [-40°C to 80°C]
Housing		NEMA type 2 / IP42, UL enclosure type 2
Housing material		UL94-5VA
Agency listings†		cULus acc. to UL60730-1A/-2-14, CAN/CSA E60730-1:02, CE acc. to 2004/108/EC
Noise level (max)	running	≤ 35 dB(A)
	spring return	≤ 62 dB(A)
Servicing		maintenance free
Quality standard		ISO 9001
Weight		1.5 lbs (0.7 kg)

† Rated Impulse Voltage 4kV, Type of action 1.AA, Control Pollution Degree 3.

Torque min. 22 in-lbs, for control of air dampers

Application

For proportional modulation of dampers in HVAC systems. Actuator sizing should be done in accordance with the damper manufacturer's specifications.

The actuator is mounted directly to a damper shaft from 1/4" up to 1/2" in diameter by means of its universal clamp, 1/2" shaft centered at delivery. A crank arm and several mounting brackets are available for applications where the actuator cannot be direct coupled to the damper shaft.

The actuator operates in response to a 2 to 10 VDC, or with the addition of a 500 Ω resistor, a 4 to 20 mA control input from an electronic controller or positioner.

Operation

The TF series actuators provide true spring return operation for reliable fail-safe application and positive close-off on air tight dampers. The spring return system provides consistent torque to the damper with, and without, power applied to the actuator.

The TF series provides 95° of rotation and is provided with a graduated position indicator showing 0 to 95°.

The TFB120-SR uses a brushless DC motor which is controlled by an Application Specific Integrated Circuit (ASIC) and a microprocessor. The microprocessor provides the intelligence to the ASIC to provide a constant rotation rate and to know the actuator's exact fail-safe position. The ASIC monitors and controls the brushless DC motor's rotation and provides a digital rotation sensing function to prevent damage to the actuator in a stall condition. The actuator may be stalled anywhere in its normal rotation without the need of mechanical end switches. Power consumption is reduced in holding mode.

Dimensions (Inches [mm])

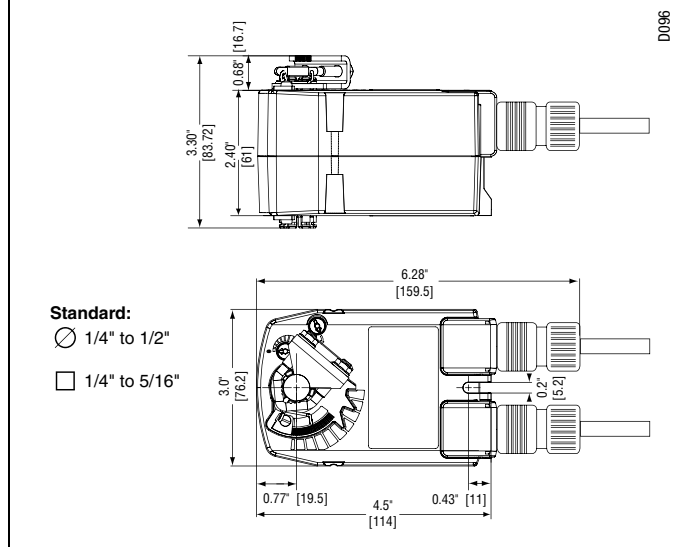

M40103 - 09/11 - Subject to change. © Belimo Aircontrols (USA), Inc.

Accessories

Tool-06	8mm and 10 mm wrench
KH-TF	Crank arm for up to 1/2" round shaft
ZG-TF2	Crank arm adaptor kit for TF
ZG-TF112	Mounting bracket, kit for TF
ZS-100	Weather shield (metal)
ZS-150	Weather shield (polycarbonate)

NOTE: When using TFB120-SR actuators, only use accessories listed on this page.
For actuator wiring information and diagrams, refer to Belimo wiring guide.

Typical Specification

Spring return control damper actuators shall be direct coupled type which require no crank arm and linkage and be capable of direct mounting to a shaft up to a 1/2" diameter and center a 1/2" shaft. The actuator must provide proportional damper control in response to a 2 to 10 VDC or, with the addition of a 500 Ω resistor, a 4 to 20 mA control input from an electronic controller or positioner. The actuators must be designed so that they may be used for either clockwise or counterclockwise fail-safe operation. Actuators shall use a brushless DC motor controlled by a microprocessor and be protected from overload at all angles of rotation. Run time shall be constant, and independent of torque. If required, one SPDT auxiliary switch shall be provided having the capability of being adjustable. Actuators with auxiliary switch must be constructed to meet the requirements for Double Insulation so an electrical ground is not required to meet agency listings. Actuators shall be cULus listed certified, have a 5 year warranty, and be manufactured under ISO 9001 International Quality Control Standards. Actuators shall be as manufactured by Belimo.

Wiring Diagrams
INSTALLATION NOTES

- CAUTION Equipment Damage!**
Up to 4 actuators may be connected in parallel. With 4 actuators wired to one 500 Ω resistor, a +2% shift of control signal may be required. Power consumption must be observed.
- Only connect common to neg. (-) leg of control circuits.
- Actuators with plenum rated cable do not have numbers on wires; use color codes instead.

APPLICATION NOTES

- Meets cULus requirements without the need of an electrical ground connection.
- The ZG-R01 500 Ω resistor converts the 4 to 20 mA control signal to 2 to 10 VDC.

WARNING Live Electrical Components!
During installation, testing, servicing and troubleshooting of this product, it may be necessary to work with live electrical components. Have a qualified licensed electrician or other individual who has been properly trained in handling live electrical components perform these tasks. Failure to follow all electrical safety precautions when exposed to live electrical components could result in death or serious injury.

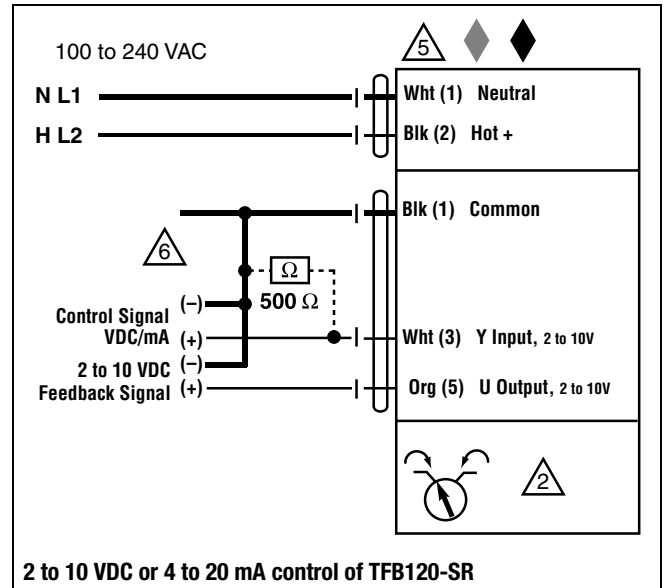

TFB24-MFT(-S), TFX24-MFT(-S)

Proportional, Spring Return, Multi-Function Technology®



MFT



Technical Data		TFB24-MFT(-S), TFX24-MFT(-S)
Power supply		24 VAC, ± 20%, 50/60 Hz 24 VDC, ±10%
Power consumption	running	2.5 W
	holding	1 W
Transformer sizing		4 VA (Class 2 power source)
Electrical connection	TFB...	3 ft, 18 GA plenum cable, 1/2" conduit connector -S models: two 3 ft, 18 gauge appliance cables with 1/2" conduit connectors
	TFX...	3 ft [1m], 10 ft [3m], or 16 ft [5m], 18 GA appliance or plenum cable, with or without 1/2" conduit connector -S models: two 3 ft [1m], 10 ft [3m] or 16 ft [5m] appliance cables with or without 1/2" conduit connectors
Overload protection		electronic throughout 0 to 95° rotation
Operating range Y*		2 to 10 VDC 4 to 20 mA (w/500 Ω, 1/4 Ω resistor) ZG-R01
Input impedance		100 kΩ for 2 to 10 VDC (0.1 mA) 500 Ω for 4 to 20 mA 1500 Ω for PWM, floating point and on/off control
Feedback output U*		2 to 10 VDC, 0.5 mA max
Torque		22 in-lbs (2.5 Nm) minimum
Direction of rotation*	spring motor	reversible with cw/ccw mounting reversible with built-in switch
Mech. angle of rotation*		max 95°, adjust with mechanical stop
Running time	motor*	150 sec constant independent of load
	spring	<25 sec @ -4°F to 122°F [-20°C to 50°C] <60 sec @ -22°F [-30°C]
Angle of rotation adaptation*		off (default)
Override control*		Min. (Min Position) = 0% - ZS (Mid. Position) = 50% - Max. (Max. Position) = 100%
Position indication		visual indicator, 0° to 95°
Humidity		5 to 95% RH, non-condensing
Ambient temperature		-22 to 122° F (-30 to 50° C)
Storage temperature		-40 to 176° F (-40 to 80° C)
Housing		NEMA 2, IP42, UL enclosure type 2
Housing material		UL 94-5VA
Noise level (max)	spring return	<35 dB (A) <65 dB (A)
Agency listings		cULus acc. to UL60730-1A/-2-14, CAN/CSA E60730-1-02, CE acc. to 2004/108/EC
Quality standard		ISO 9001
Servicing		maintenance free
Weight		1.4 lbs. (0.6 kg), 1.5 lbs (0.7 kg) with switch

* Variable when configured with MFT options

† Rated Impulse Voltage 800V, Type of action 1.AA, Control Pollution Degree 3.

TFB24-MFT-S, TFX24-MFT-S	
Auxiliary switch	1 x SPDT 3A (0.5A) @ 250 VAC, UL approved adjustable 0° to 95° (double insulated)

- Torque min. 22 in-lb.
- Control 2 to 10 VDC (Default)
- Feedback 2 to 10 VDC (Default)

Application

For proportional modulation of dampers in HVAC systems. Actuator sizing should be done in accordance with the damper manufacturer's specifications.

Default/Configuration

Default parameters for 2 to 10 VDC applications of the TF-MFT actuator are assigned during manufacturing. If required, custom versions of the actuator can be ordered. The parameters noted in the Technical Data table are variable.

These parameters can be changed by three means:

- Pre-set configurations from Belimo
- Custom configurations from Belimo
- Configurations set by the customer using the MFT PC tool software application.

Operation

The TF series actuators provide true spring return operation for reliable fail-safe application and positive close-off on air tight dampers. The spring return system provides consistent torque to the damper with, and without, power applied to the actuator.

The TF series provides 95° of rotation and is provided with a graduated position indicator showing 0 to 95°.

The TF uses a brushless DC motor which is controlled by an Application Specific Integrated Circuit (ASIC) and a microprocessor. The microprocessor provides the intelligence to the ASIC to provide a constant rotation rate and to know the actuator's exact fail-safe position. The ASIC monitors and controls the brushless DC motor's rotation and provides a digital rotation sensing function to prevent damage to the actuator in a stall condition. The actuator may be stalled anywhere in its normal rotation without the need of mechanical end switches. Power consumption is reduced in holding mode.

The TF-S version is provided with one built-in auxiliary switch. This SPDT switch is provided for safety interfacing or signaling, for example, for fan start-up. The switching function is adjustable between 0° and 95°. The auxiliary switch in the TF-S is double insulated so an electrical ground is not necessary.

SAFETY NOTE

Screw a conduit fitting into the actuator's bushing. Jacket the actuator's input and output wiring with suitable flexible conduit. Properly terminate the conduit in a suitable junction box.

Dimensions (Inches [mm])

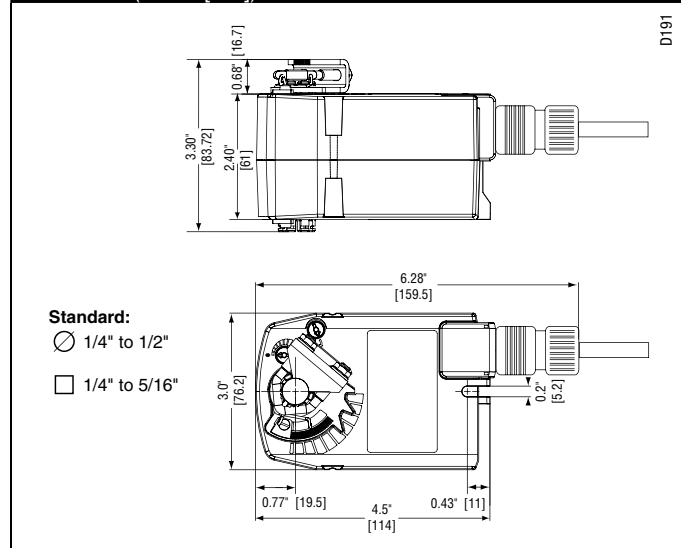

M40103 - 09/11 - Subject to change. © Belimo Aircontrols (USA), Inc.

Accessories

Tool-06	8mm and 10 mm wrench
KH-TF	Crank arm for up to 1/2" round shaft
ZG-TF2	Crank arm adaptor kit for TF
ZG-TF112	Mounting bracket, kit for TF
ZS-100	Weather shield (metal)
ZS-150	Weather shield (polycarbonate)

NOTE: When using TFB24-MFT (-S), TFX24-MFT (-S) actuators, only use accessories listed on this page. For actuator wiring information and diagrams, refer to Belimo wiring guide.

Typical Specification

Spring return control damper actuators shall be direct coupled type which require no crank arm and linkage and be capable of direct mounting to a shaft up to a 1/2" diameter and center a 1/2" shaft. The actuator must provide proportional damper control in response to a 2 to 10 VDC or, with the addition of a 500 Ω resistor, a 4 to 20 mA control input from an electronic controller or positioner. The actuators must be designed so that they may be used for either clockwise or counterclockwise fail-safe operation. Actuators shall use a brushless DC motor controlled by a microprocessor and be protected from overload at all angles of rotation. Run time shall be constant, and independent of torque. If required, one SPDT auxiliary switch shall be provided having the capability of being adjustable. Actuators with auxiliary switch must be constructed to meet the requirements for Double Insulation so an electrical ground is not required to meet agency listings. Actuators shall be cULus listed certified, have a 5 year warranty, and be manufactured under ISO 9001 International Quality Control Standards. Actuators shall be as manufactured by Belimo.

Wiring Diagrams

INSTALLATION NOTES

- 1 Provide overload protection and disconnect as required.
- 2 **CAUTION Equipment Damage!**
Actuators may be connected in parallel if not mechanically mounted to the same shaft. Power consumption and input impedance must be observed.
- 3 Actuators may also be powered by 24 VDC.
- 4 Position feedback cannot be used with Triac sink controller. The actuator internal common reference is not compatible.
- 5 Control signal may be pulsed from either the Hot (source) or the Common (sink) 24 VAC line.
- 8 Contact closures A & B also can be triacs. A & B should both be closed for triac source and open for triac sink.
- 9 For Triac sink the common connection from the actuator must be connected to the hot connection of the controller.

APPLICATION NOTES

- ◆ The ZG-R01 500 Ω resistor may be used.
- ◆ Meets UL requirements without the need of an electrical ground connection.

WARNING Live Electrical Components!

During installation, testing, servicing and troubleshooting of this product, it may be necessary to work with live electrical components. Have a qualified licensed electrician or other individual who has been properly trained in handling live electrical components perform these tasks. Failure to follow all electrical safety precautions when exposed to live electrical components could result in death or serious injury.

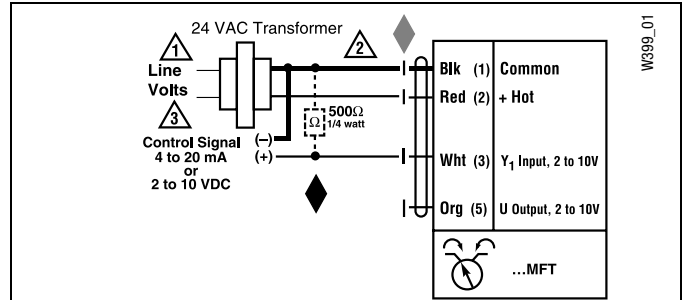

VDC/ 4-20 mA

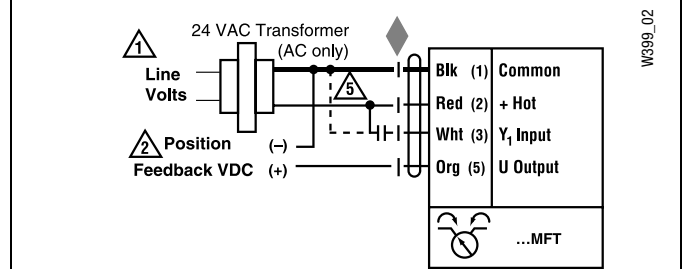

PWM

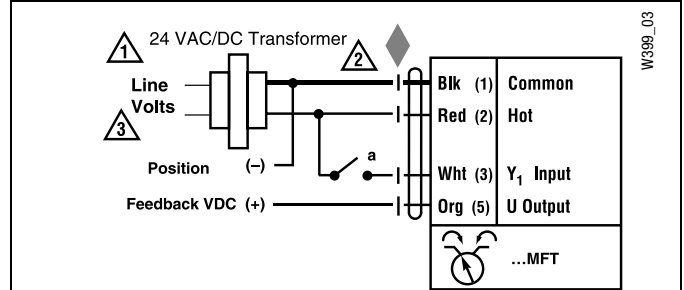

On/Off Control

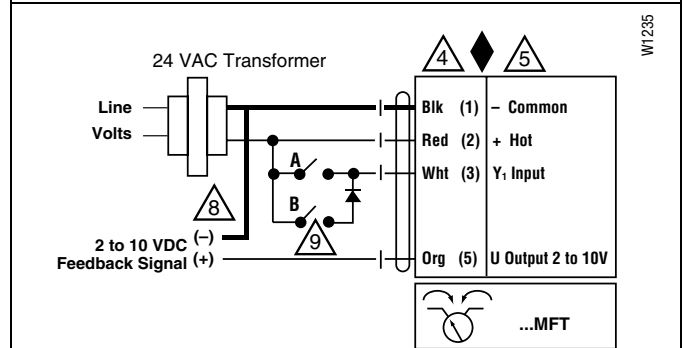

Floating Point Control

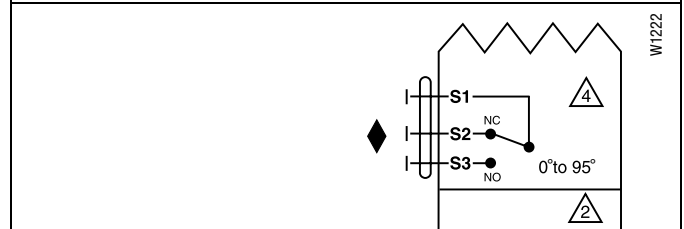

Auxiliary switch of TFB24-MFT(-S), TFX24-MFT(-S)

Installation Instructions

Quick-Mount Visual Instructions for Mechanical Installation



Quick-Mount Visual Instructions

1. Rotate the damper to its failsafe position. If the shaft rotates counterclockwise, mount the "CCW" side of the actuator out. If it rotates clockwise, mount the actuator with the "CW" side out.
2. If the universal clamp is not on the correct side of the actuator, move it to the correct side.
3. Slide the actuator onto the shaft and tighten the nuts on the V-bolt with an 8mm wrench to 6-8 ft-lb of torque.
4. Slide the anti-rotation strap under the actuator so that it engages the slot at the base of the actuator. Secure the strap to the duct work with #8 self-tapping screws.

NOTE: Read the "Standard Mounting" instructions, for more detailed information.

Preliminary Steps

1. Belimo actuators should be mounted indoors in dry, relatively clean environment free from corrosive fumes. If the actuator is to be mounted outdoors, a protective enclosure must be used to shield the actuator. (See Mechanical Accessories Section)
2. For new construction work, order dampers with extended shafts. Instruct the installing contractor to allow space for mounting and service of the Belimo actuator on the shaft.
3. For standard mounting, the damper shaft must extend at least 3 1/2" from the duct. If the shaft extends less than 3 1/2", the actuator may be mounted in its short shaft configuration.

Dimensions (Inches [mm])

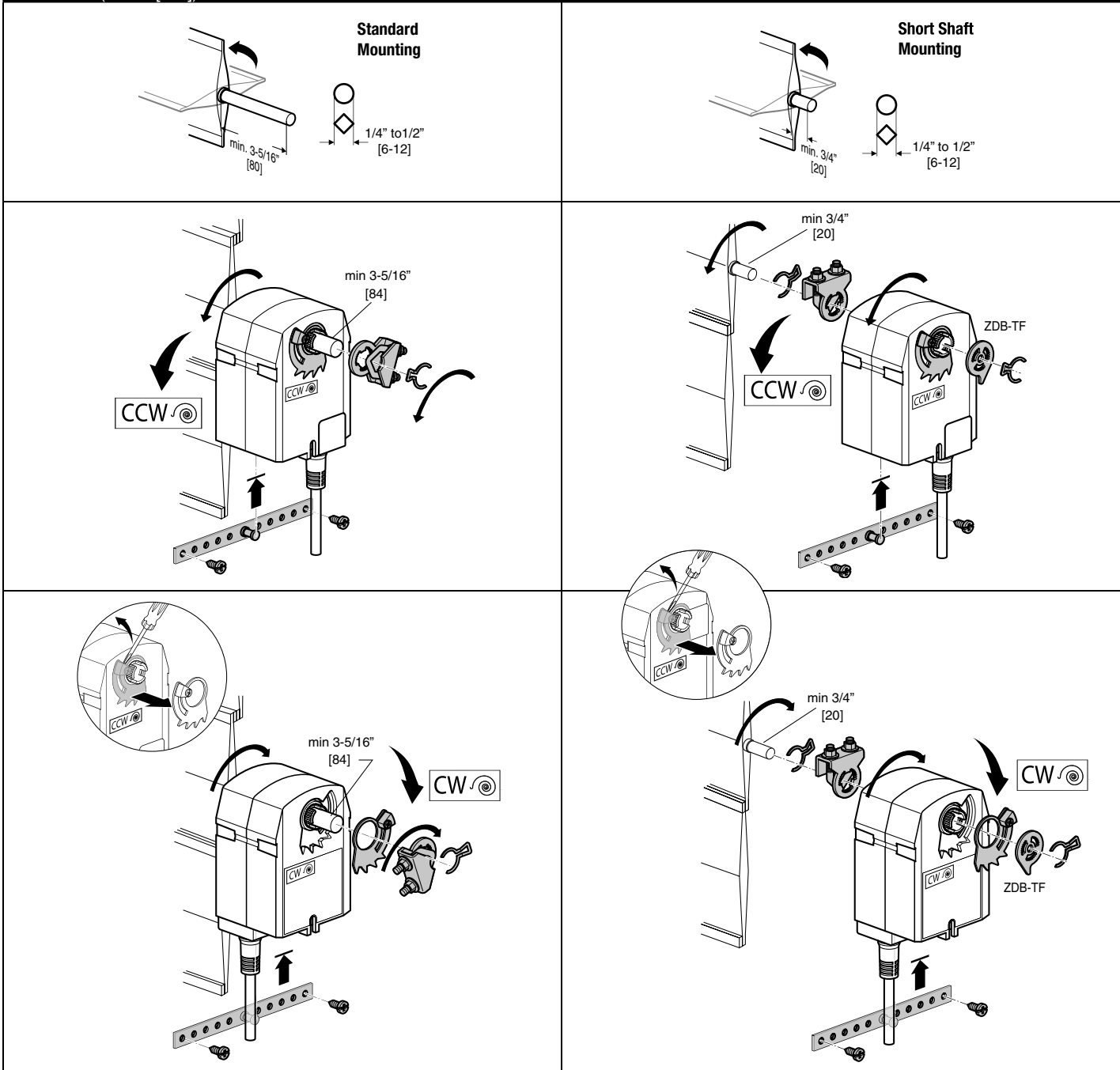

M40103 - 09/11 - Subject to change. © Belimo Aircontrols (USA), Inc.

Mechanical Operation

The actuator is mounted directly to a damper shaft up to 1/2" in diameter by means of its universal clamp. A crank arm and several mounting brackets are available for applications where the actuator cannot be direct coupled to the damper shaft.

The TF series actuators provide true spring return operation for reliable fail-safe application and positive close-off on air tight dampers. The spring return system provides consistent torque to the damper with, and without, power applied to the actuator.

The TF series provides 95° of rotation and is provided with a graduated position indicator showing 0 to 95°.

The TF...-S versions are provided with 1 built-in auxiliary switch. This SPDT switch is provided for safety interfacing or signaling, for example, for fan start-up. The switching function is adjustable between 0° and 95°.

Standard Mounting / Airtight Damper Procedure

1. See **Figure B**. Manually move the damper to the fail-safe position (a) (usually closed). If the shaft rotated counterclockwise (↺), this is a CCW installation. If the shaft rotated clockwise (↻), this is a CW installation. In a Left Hand installation, the actuator side marked "CW" faces out, while in a CW installation, the side marked "CCW" faces out. All other steps are identical.
2. The actuator is usually shipped with the universal clamp mounted to the "CW" side of the actuator. To test for adequate shaft length, slide the actuator over the shaft with the side marked "CW" (or the "CCW" side if this is the side with the clamp). If the shaft extends at least 1/8" through the clamp, mount the actuator as follows. If not, go to the Short Shaft Installation section.
3. If the clamp is not on the correct side as determined in step #1, re-mount the clamp as follows. If it is on the correct side, proceed to step #5. Look at the universal clamp. If you are mounting the actuator with the "CCW" side out, position the clamp so that the pointer section of the tab is pointing to 0° (see Fig. C) and the spline pattern of the clamp mates with spline of the actuator. Remount the stroke limiter to this side then slip the clamp over the spline. (Use the same procedure if the "CW" side is out.)
4. See Remounting the Stroke Limiter after the section Short Shaft Mounting with IND-TF Position Indicator.
5. Lock the clamp to the actuator using the retaining clip.
6. Verify that the damper is still in its full fail-safe position. (a)
7. Mount the spring return actuator to the shaft. Tighten the universal clamp, finger tight only.
8. Mount the anti-rotation strap at the base of the actuator. Do not tighten the screws.
9. Remove the screw from one end of the mounting bracket and pivot it away from the actuator.
10. Loosen the universal clamp and, making sure not to move the damper shaft, rotate the actuator approximately 5° in the direction which would open the damper.
11. Tighten the universal clamp to the shaft.
12. Rotate the actuator to apply pressure to the damper seals (b) and re-engage the anti-rotation strap (c).
13. Tighten all fasteners.

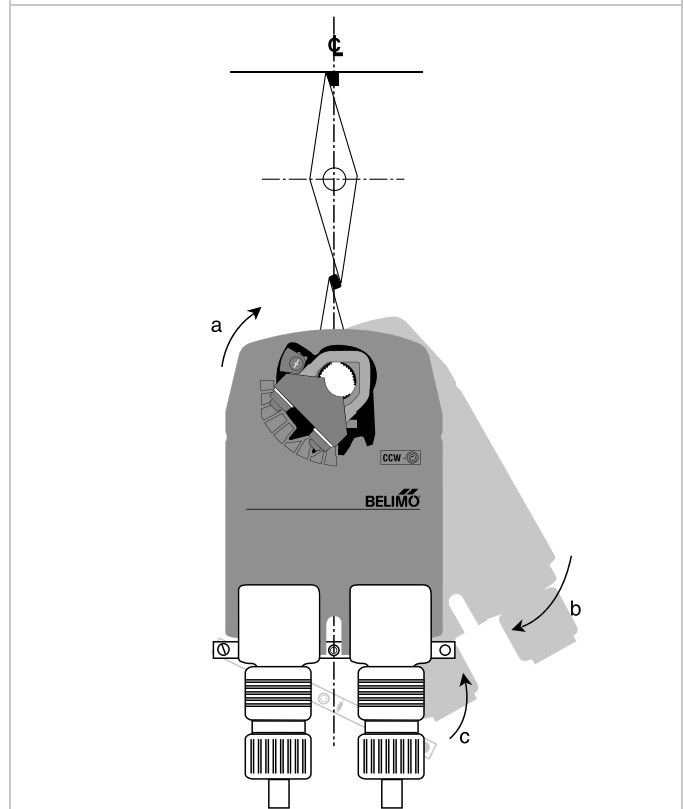
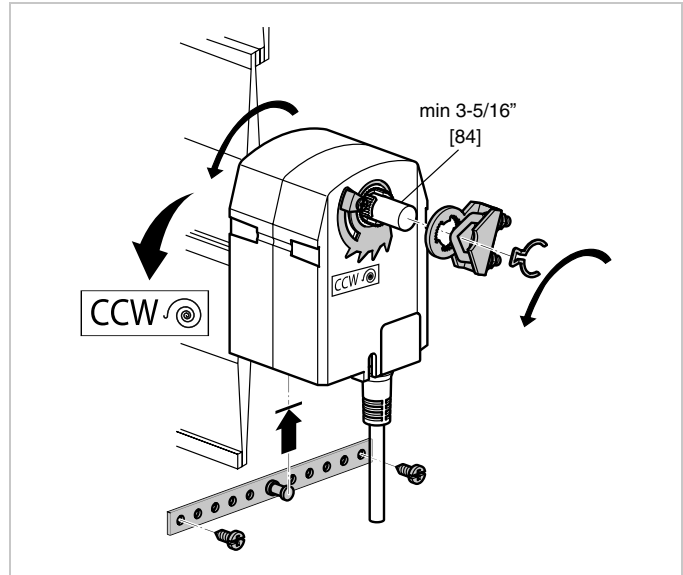

FIGURE B – Standard Mounting (Dimensions in Inches [mm])

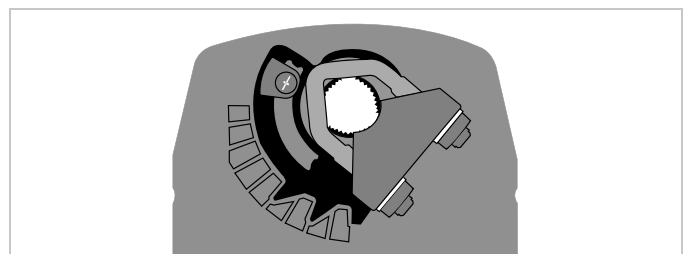

FIGURE C – Universal Clamp

Short Shaft Mounting with IND-TF Position Indicator / Airtight Damper Procedure

If the shaft extends at least 3/4" from the duct, follow these steps:

1. (See **Figure D**) Move damper blades to the fail-safe position (a).
2. Determine the best orientation for the universal clamp on the back of the actuator. The best location would be where you have the easiest access to the V bolt nuts on the clamp.
3. Engage the clamp to the actuator as close as possible to the determined location.
4. Lock the clamp to the actuator using the retainer clip.
5. Mount the spring return actuator to the shaft. Tighten the universal clamp, finger tight only.
6. Mount the anti-rotation strap at the base of the actuator. Do not tighten the screws.
7. Remove the screw from one end of the mounting bracket and pivot it away from the actuator.
8. Loosen the universal clamp and, making sure not to move the damper shaft, rotate the actuator approximately 5° in the direction which would open the damper.
9. Verify that the damper is still in its full fail-safe position.
10. Tighten the universal clamp to the shaft.
11. Rotate the actuator to apply pressure to the damper seals (b) and re-engage the anti-rotation strap (c).
12. Tighten all fasteners.
13. Use IND-TF accessory if position indication is needed.

Remounting the Stroke Limiter

1. Remove the stroke limiter by inserting a small screwdriver, like the one shown, and gently prying upward. This procedure takes very little force. See **Figure 1**.
2. While holding the back eye-let, unscrew the end-stop so that eye-let separates from the end-stop.
3. Flip the limiter over, so the teeth point the other direction. Replace the eye-let and end-stop.
4. Flip the actuator over to the opposite side (this reverses the spring return direction of the actuator). Replace the stroke limiter assembly by inserting the first two teeth as shown in the orange circle. Then press the stroke limiter into place by pushing downward on the adjustable stop.
5. Replace clamp and retaining clip.

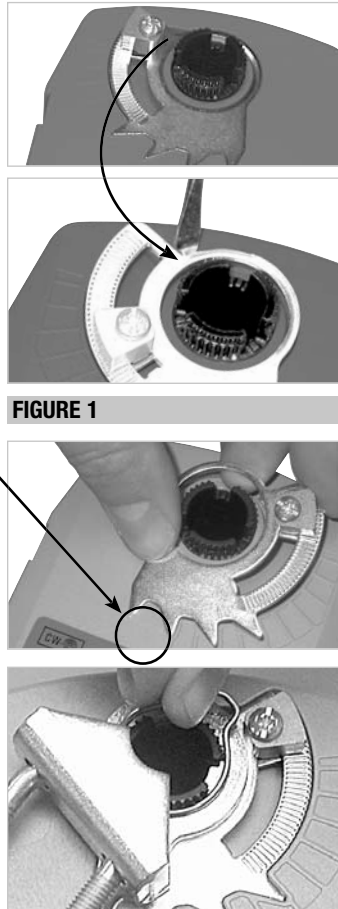

FIGURE 1

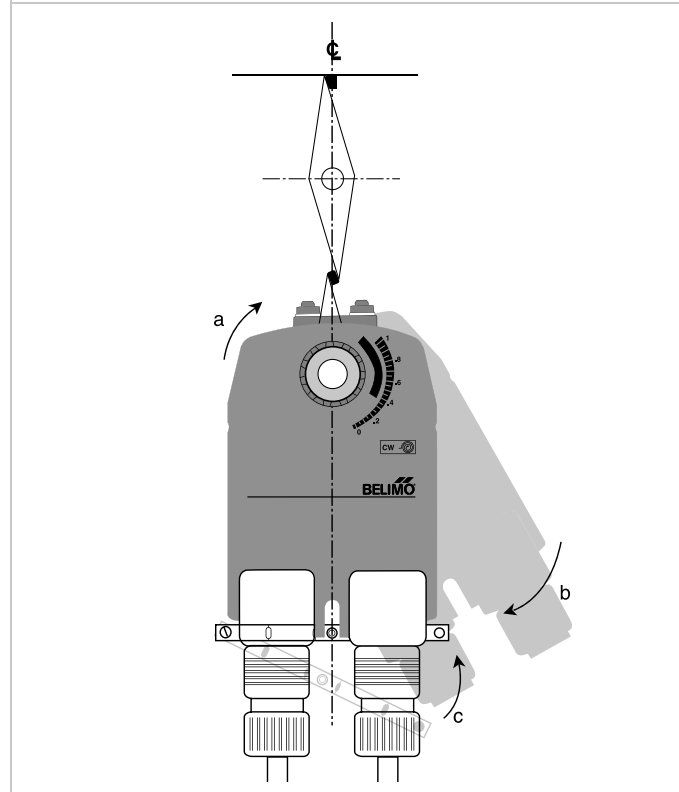
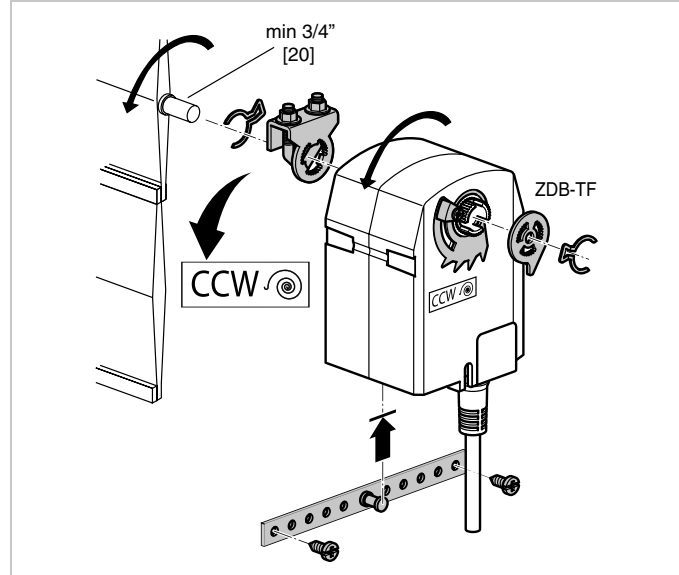

FIGURE D – Standard Mounting (Dimensions in Inches [mm])

Operational Information for TF Actuators

Initialization of the TFB24-SR(-S)

When power is applied, the internal microprocessor recognizes that the actuator is at its full fail-safe position and uses this position as the base for all of its position calculations. This procedure takes approximately 15 seconds. During this time you will see no response at the actuator. The microprocessor will retain the initialized zero during short power failures of up to 25 seconds. When power is applied during this period, the actuator will return to normal operation and proceed to the position corresponding to the input signal provided. For power failures over 25 seconds, the actuator will be at its fail-safe position and will go through the start up initialization again.

Motor position detection TFB24-SR(-S)

Belimo brushless DC motors eliminate the need for potentiometers for positioning. Inside the motor are three "Hall Effect" sensors. These sensors detect the spinning rotor and send pulses to the microprocessor which counts the pulses and calculates the position to within 1/3 of a revolution of the motor.

Overload protection

The TF on/off actuators are electronically protected against overload. The TF on/off actuator have an internal current limiter which maintains the current at a safe level which will not damage the actuator while providing adequate holding torque.

The TF modulating actuators (TFB24-SR(-S), TFB24-3(-S), TFB120-SR) are protected against overload by digital technology located in the ASIC. The ASIC circuitry constantly monitors the rotation of the brushless DC motor inside the actuator and stops the pulsing to the motor when it senses a stall condition. The motor remains energized and produces full rated torque during stall conditions. The actuator will try to move in the direction of the stall every 2 minutes, for a period of 32 minutes. After this, the actuator will try again every 2 hours.

Mechanical Angle of Rotation Limiting

The TF actuators are provided with an adjustable stop to limit the rotation of the actuator. This function works in conjunction with the universal clamp or the optional position indicator. The adjustable stop is needed when rotation of less than 95° is required. The TF actuator can be indefinitely stalled, in any position, without harming the actuator.

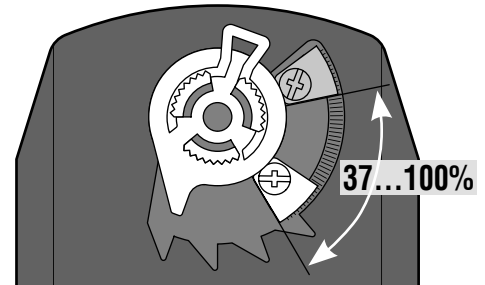

Using the Universal Clamp

1. Loosen the end stop fastening screw using a #2 Phillips screwdriver.
2. Move the stop block so the bottom edge of the block lines up with the number corresponding to the desired degrees of rotation. (example: 45 degrees of rotation = 0.5)
3. Lock the block in place with the fastening screw.
4. Check the actuator for proper rotation.

Using the IND-TF Position Indicator with Adjustable Stop

NOTE: preferred method if short shaft mounting is used.

1. With the actuator in its fail-safe position, place the IND-TF Position Indicator so that it points to the 0 degree position.
2. Loosen the end stop fastening screw using a #2 Phillips screwdriver.
3. Move the stop block so the bottom edge of the block lines up with the number corresponding to the desired degrees of rotation (example: 45 degrees of rotation = 0.5).
4. Lock the block in place with the fastening screw.
5. Check the actuator for proper rotation.

Direction of Rotation Switch

TFB24-3(-S), TFB24-SR(-S), and TFB120-SR actuators have a direction of rotation switch on the cover marked "↺↻" for CCW or CW respectively. Switch position indicates start point. For the TFB24-SR, with the switch in position "CW", the actuator rotates clockwise with a decrease in voltage or current. With the switch in position "CCW", the actuator rotates counterclockwise with a decrease in voltage or current.

The TFB24-3(-S) actuator rotates clockwise when the switch is in the "CW" position and power is applied to wire #3. When power is applied to wire #4 the actuator rotates counter clockwise.

Rotating the direction of rotation switch to "CCW" reverses the control logic.

During checkout, the switch position can be temporarily reversed and the actuator will reverse its direction. This allows the technician a fast and easy way to check the actuator operation without having to switch wires or change settings on the controller. **When the check-out is complete, make sure the switch is placed back to its original position.**

Installation Instructions

Mechanical Installation



Auxiliary Switches

The ...-S model actuators are equipped with an adjustable auxiliary switch used to indicate damper position or to interface additional controls or equipment. Switching positions can be set over the full 0 to 95° rotation simply by setting a switch on the actuator.

1. Set desired switch position.
(Example 60%)
2. As the actuator rotates, the switch indicator moves from .6 (60%) toward 0 (0%).

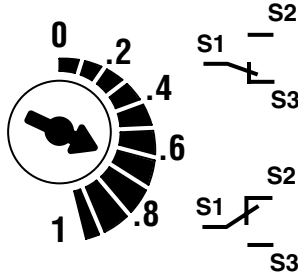

Switch Rating

Voltage	Resistive load	Inductive load
250 VAC	3 A	0.5 A

Control Accuracy and Stability

-SR and MFT TF actuators have built-in brushless DC motors which provide better accuracy and longer service life.

The -SR and MFT TF actuators are designed with a unique non-symmetrical deadband. The actuator follows an increasing or decreasing control signal with a 160 mV resolution. If the signal changes in the opposite direction, the actuator will not respond until the control signal changes by 200 mV. This allows these actuators to track even the slightest deviation very accurately, yet allowing the actuator to "wait" for a much larger change in control signal due to control signal instability.

TF Actuator responds to a 160 mV signal when not changing direction from stop position.

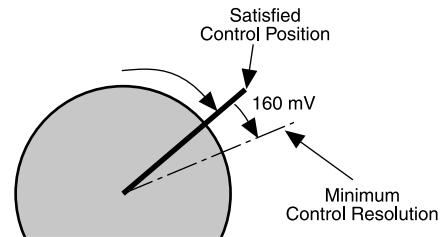

TF Actuator responds to a 200 mV signal when reversing direction from stop position.

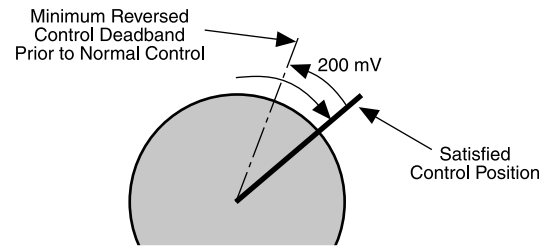

Non-Direct Mounting Methods

ZG-TF2 Crank arm Adaptor Kit

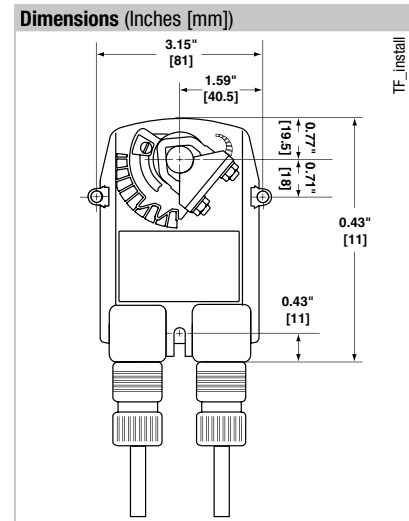
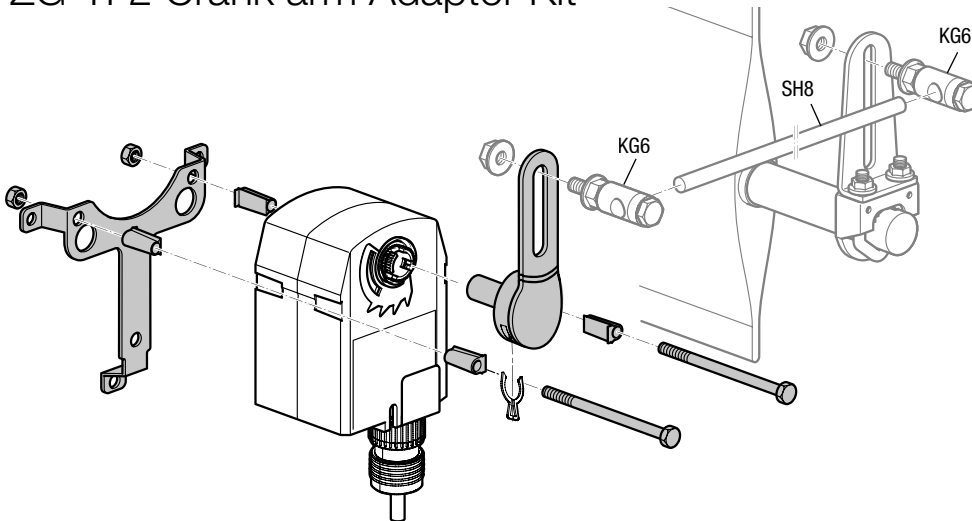

M40103 - 09/11 - Subject to change. © Belimo Aircontrols (USA), Inc.

WARNING The wiring technician must be trained and experienced with electronic circuits. Disconnect power supply before attempting any wiring connections or changes. Make all connections in accordance with wiring diagrams and follow all applicable local and national codes. Provide disconnect and overload protection as required. Use copper, twisted pair, conductors only. If using electrical conduit, the attachment to the actuator must be made with flexible conduit.

Always read the controller manufacturer's installation literature carefully before making any connections. Follow all instructions in this literature. If you have any questions, contact the controller manufacturer and/or Belimo.

Transformers

The TF24 . . actuator requires a 24 VAC class 2 transformer and draws a maximum of 5 VA per actuator. The actuator enclosure cannot be opened in the field, there are no parts or components to be replaced or repaired.

- EMC directive: 2004/108/EC
- Software class A: Mode of operation type 1
- Low voltage directive: 2006/95/EC

CAUTION It is good practice to power electronic or digital controllers from a separate power transformer than that used for actuators or other end devices. The power supply design in our actuators and other end devices use half wave rectification. Some controllers use full wave rectification. When these two different types of power supplies are connected to the same power transformer and the DC commons are connected together, a short circuit is created across one of the diodes in the full wave power supply, damaging the controller. Only use a single power transformer to power the controller and actuator if you know the controller power supply uses half wave rectification.

Multiple Actuators, One Transformer

Multiple actuators may be powered from one transformer provided the following rules are followed:

1. The TOTAL current draw of the actuators (VA rating) is less than or equal to the rating of the transformer.
2. Polarity on the secondary of the transformer is strictly followed. *This means that all No. 1 wires from all actuators are connected to the common leg on the transformer and all No 2 wires from all actuators are connected to the hotleg.* Mixing wire No. 1 & 2 on one leg of the transformer will result in erratic operation or failure of the actuator and/or controls.

Multiple Actuators, Multiple Transformers

Multiple actuators positioned by the same control signal may be powered from multiple transformers provided the following rules are followed:

1. The transformers are properly sized.
2. All No. 1 wires from all actuators are tied together and tied to the negative leg of the control signal. See wiring diagram.

Wire Length for TF... Actuators

Keep power wire runs below the lengths listed in the table in **Figure A**. If more than one actuator is powered from the same wire run, divide the allowable wire length by the number of actuators to determine the maximum run to any single actuator.

Example for TFB24-SR: 3 actuators, 16 Ga wire
 $550 \text{ Ft} \div 3 \text{ Actuators} = 183 \text{ Ft. Maximum wire run}$

TFB24(-S) / TFB120(-S) Maximum Wire Length

Wire Size	Max. Feet.	Wire Size	Max. Feet
12 Ga	1300 Ft.	18 Ga	575 Ft.
14 Ga	1175 Ft.	20 Ga	300 Ft.
16 Ga	900 Ft.	22 Ga	150 Ft.

TFB24-3(-S) Maximum Wire Length

Wire Size	Max. Feet.	Wire Size	Max. Feet
16 Ga	1125 Ft.	20 Ga	400 Ft.
18 Ga	725 Ft.	22 Ga	200 Ft.

TFB24-SR(-S), TFB24-MFT Maximum Wire Length

Wire Size	Max. Feet.	Wire Size	Max. Feet
12 Ga	1800 Ft.	18 Ga	450 Ft.
14 Ga	1100 Ft.	20 Ga	275 Ft.
16 Ga	700 Ft.	22 Ga	125 Ft.

FIGURE A

Wire Type and Wire Installation Tips

For most installations, 18 or 16 Ga. cable works well with the TFB24... actuators. Use code-approved wire nuts, terminal strips or solderless connectors where wires are joined. It is good practice to run control wires unspliced from the actuator to the controller. If splices are unavoidable, make sure the splice can be reached for possible maintenance. Tape and/or wire-tie the splice to reduce the possibility of the splice being inadvertently pulled apart.

The TFB24... proportional actuators have a digital circuit that is designed to ignore most unwanted input signals (pickup). In some situations the pickup may be severe enough to cause erratic running of the actuator. For example, a large inductive load (high voltage AC wires, motors, etc.) running near the power or control wiring may cause excessive pickup. To solve this problem, make one or more of the following changes:

1. Run the wire in metallic conduit.
2. Re-route the wiring away from the source of pickup.
3. Use shielded wire (Belden 8760 or equal). Ground the shield to an earth ground. Do not connect it to the actuator common.

Brushless DC Motor Operation

Belimo's brushless DC motor spins by reversing the poles of stationary electromagnets housed inside rotating permanent magnets. The electromagnetic poles are switched by a microprocessor and a special ASIC (Application Specific Integrated Circuit) developed by Belimo. Unlike the conventional DC motor, there are no brushes to wear or commutators to foul.

TFB24-SR(-S) Electrical Check-Out Procedure				
STEP	Procedure	Expected Response	Gives Expected Response Go To Step...	Does Not Give Expected Response Go To Step...
1.	Remove power to reset actuator. Re-apply power. Apply control signal to actuator.	Actuator will move to its "Control Signal" position.	Actuator operates properly Step 8.	No response at all Step 2. Operation is reversed Step 3. Does not drive toward "Control Signal Position" Step 4.
2.	Check power wiring. Correct any problems. See Note 1.	Power supply rating should be the total power requirement of the actuator(s). Minimum voltage of 19.2 VAC or 21.6 VDC.	Power wiring corrected, actuator begins to drive Step 1.	Power wiring corrected, actuator still does not drive Step 4.
3.	Turn reversing switch to the correct position. Make sure the switch is turned all the way left or right.	Actuator will move to its "Control Signal" position.	Actuator operates properly Step 8.	Does not drive toward "Control Signal Position" Step 4.
4.	Make sure the control signal positive (+) is connected to Wire No 3 and control signal negative (-) is connected to wire No. 1. Most control problems are caused by reversing these two wires. Verify that the reversing switch is all the way CCW or CW.	Drives to "Control Signal" position.	Actuator operates properly Step 8.	Step 5.
5.	Check input signal with a digital volt meter (DVM). Make sure the input is within the range of the actuator. For TFB24-SR this is 2 to 10 VDC or 4 to 20 mA. Note: The input signal must be above the 2 VDC or 4 mA to have the actuator move.	Input voltage or current should be $\pm 1\%$ of what controller's adjustment or programming indicate.	Controller output (actuator input) is correct. Input Polarity Correct Step 6.	Reprogram, adjust repair or replace controller as needed Step 1.
6.	Loosen the nuts on the V-bolt and move the damper by hand from fully closed to fully open.	Damper will go from fully closed to fully open.	Damper moves properly Step 7.	Find cause of damper jam and repair. Move damper back to the fully closed position and tighten the nuts Step 1.
7.	Check damper torque requirement.	Torque requirement is actuator's minimum torque.	Defective Actuator. Replace Actuator - See Note 2.	Recalculate actuator requirement and correct installation.
8.	Actuator works properly. Test controller by following controller manufacturer's instructions.			

- NOTE 1** Check that the transformer(s) are sized properly.
- If a common transformer is used, make sure that polarity is observed on the secondary. This means connect all No. 1 wires to one leg of the transformer and all No. 2 wires to the other leg of the transformer.
 - If multiple transformers are used with one control signal, make sure all No. 1 wires are tied together and tied to control signal negative (-).
 - Controllers and actuators must have separate 24 VAC/VDC power sources.
- NOTE 2** If failure occurs within 5 years from original installation date, notify Belimo and give details of the application.