

Movement by Perfection



**Axial fans
FE2owlet-ECQ**

Edition 06/2015

The Royal League in ventilation, control and drive technology

Air with IQ

Air is inert by nature. Influences in nature such as temperature gradients start moving the air – but unfortunately, in a rather uncontrolled way and not always to people's advantage. In order to make air movement useful, we recommend our intelligent ventilation and control engineering solutions. They are not only effective and reliable but are also aimed at a multitude of specific requirements. As the world's leading system supplier of fans with matching control engineering, you will certainly be able to find fans for your sector and application in our product range. Educated minds don't leave anything to chance. Instead, they trust ZIEHL-ABEGG's extensive expertise.

FANselect

Reach your goal easily, quickly, and without any complications! The world's most precise program for fans and systems components. For more information log on to our website at www.fanselect.info



Additional catalogues

Our extensive catalogues in Axial Fans, Centrifugal Fans, Centrifugal Fans for air handling units, Control Technology and other catalogues are available on our www.ziehl-abegg.com website in the "Download" area. We would be glad to send printed catalogues on request.

Contents

The ZIEHL-ABEGG Company		Page 4
Motor ECQ		Page 8
FE2owlet-ECQ		Page 10
Control technology		Page 48
General notes		Page 52
ZIEHL-ABEGG global		Page 59



ZIEHL-ABEGG

Die Königsklasse

der Lufttechnik,
Regeltechnik und Antriebstechnik

Radialventilator
ZAmid®Technologie



No one can get past the Royal League



ZIEHL-ABEGG has stood for movement by perfection in the ventilation technology, control technology and drive technology sectors for more than 100 years. What started with the invention of the first external rotor motor by Emil Ziehl is now being carried on at the company's sites around the world. We are the pioneers, masterminds and developers of technologies for the future who more than satisfy all demands to preserve an environment worth living in and to meet all our customers' requirements and wishes.

Think in the future - discover ZIEHL-ABEGG

We look forward to seeing you in ventilation, control and drive technology. There, where ideas are the daily challenge and where the latest, outstanding technologies are developed.

Welcome to the best.

Welcome to the Royal League

From fans and motors to matching control technology

Our unique selling point – your advantage

What is important to us is to correctly match our systems to your specific needs. Whether refrigeration, air conditioning, for use in your manufacturing processes or anywhere else - we reliably move air wherever it is required and at the right time. At the main Künzelsau location more than 100 engineers and technicians work in one of the most modern technology centers of this kind.

We supply the highest quality standards with **the world's largest air and noise test-bench for fans** which can completely mask vibrations and external noises. This guarantees fan measurements of the highest class according to ISO and DIN. This is the reason ZIEHL-ABEGG products with the **Premium Quality** and **Premium Efficiency** are certified - that is the reason our products and services are in the Royal League.

The world's most modern and largest test-bench for fans at the main location in Künzelsau

Right picture:
Most modern production lines for fans with the highest demands in the world

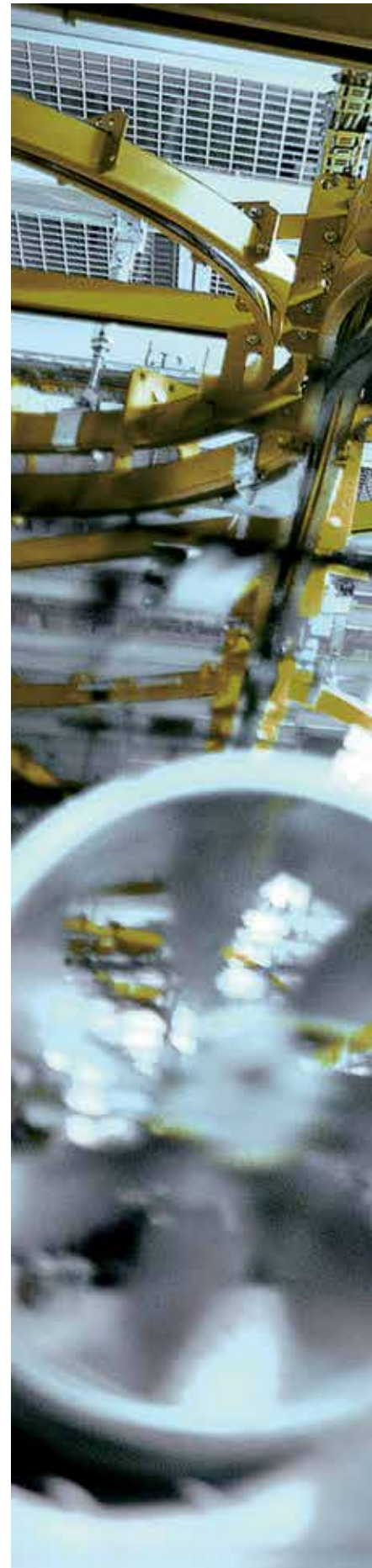



Technical description

Motor ECQ



ECQ motors from ZIEHL-ABEGG are highly efficient, electronically commuted motors (EC) with an integrated controller. The motors are designed for continuous operation (S1-operation) and are thermally protected. An insulated IP55 housing of highly resistant plastic ensures safe operation in many different environments with high humidity or extreme cold.

Description

Motor technology: EC
 Rated voltage U: 1~200...264 V* / 1~ 100...134 V*
 Rated frequency f: 50/60 Hz*
 Rated current I: 0,25 A* / 0,42 A*
 Thermic class: THCL130*
 Max. authorised media temperature $t_{R(min)}$: -40 °C
 Max. authorised media temperature $t_{R(max)}$: 50 °C
 Electrical connection: Integrated controller with attached cable
 Protection rating: IP55
 Protection class: II (no PE conductor)
 Conformity: CE
 Authorisation: UL - Recognized Component acc. UL 1004-3, CCC
ErP-data
 Does not come under the stipulations of the ErP directives
 *Rating plate data

ECQ 1~ 120 V		
Type	Article no.	Speed (3/2/1)
MI060-4QN.05.N	169791	1750/1300/1000
MI060-4QN.05.N	169792	2200/1550/1300

ECQ 1~ 230 V		
Type	Article no.	Speed (3/2/1)
MI060-4QN.05.N	151811	1750/1300/1000
MI060-4QN.05.N	151812	2200/1550/1300

Dimensions mm

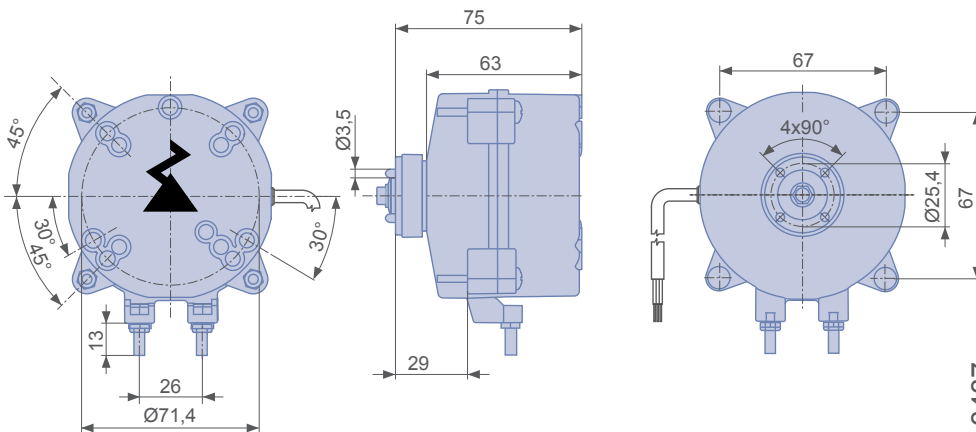

L-KL-3437

Connection diagram 1360-334

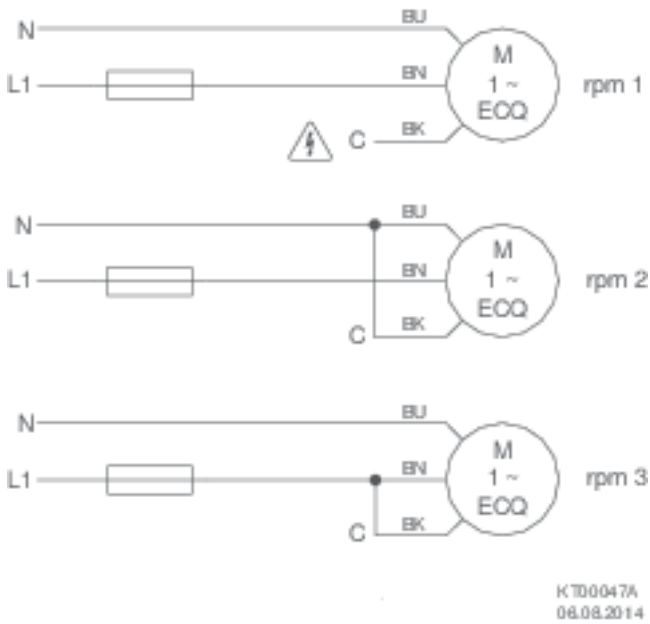

ECQ motors can be used multi-functionally with 3 speeds and reverse operation. Each speed can be adapted individually according to your application.

Switching takes place via a control cable in the cable harness. The contact is switched to "N" or "L1" depending on the operating mode, this makes ECQ motors compatible with all common control units. The motor has devices to protect it from overloading, these include protection in case of blocked rotor and overload protection with running motor.

BU = blue
BN = brown
BK = black
rpm1 = Speed1
rpm2 = Speed2
rpm3 = Speed3

FE2owlet-ECQ

Description

Profiled, sickle blades according to bionic principles with highly efficient EC drives
Ø 172...300 mm

Application

Refrigerator counters/cabinets, deep freezers, cold store rooms, etc.

Advantages

The FE2owlet-ECQ fans feature very low noise and high efficiency. The EC technology and the bionic blade design create a unique and highly innovative fan.
3 speed stages with reverse operation enable adapted operating modes such as 1"Day-2"Night-3"Cleaning.

Accessories

Motor-brackets on request.



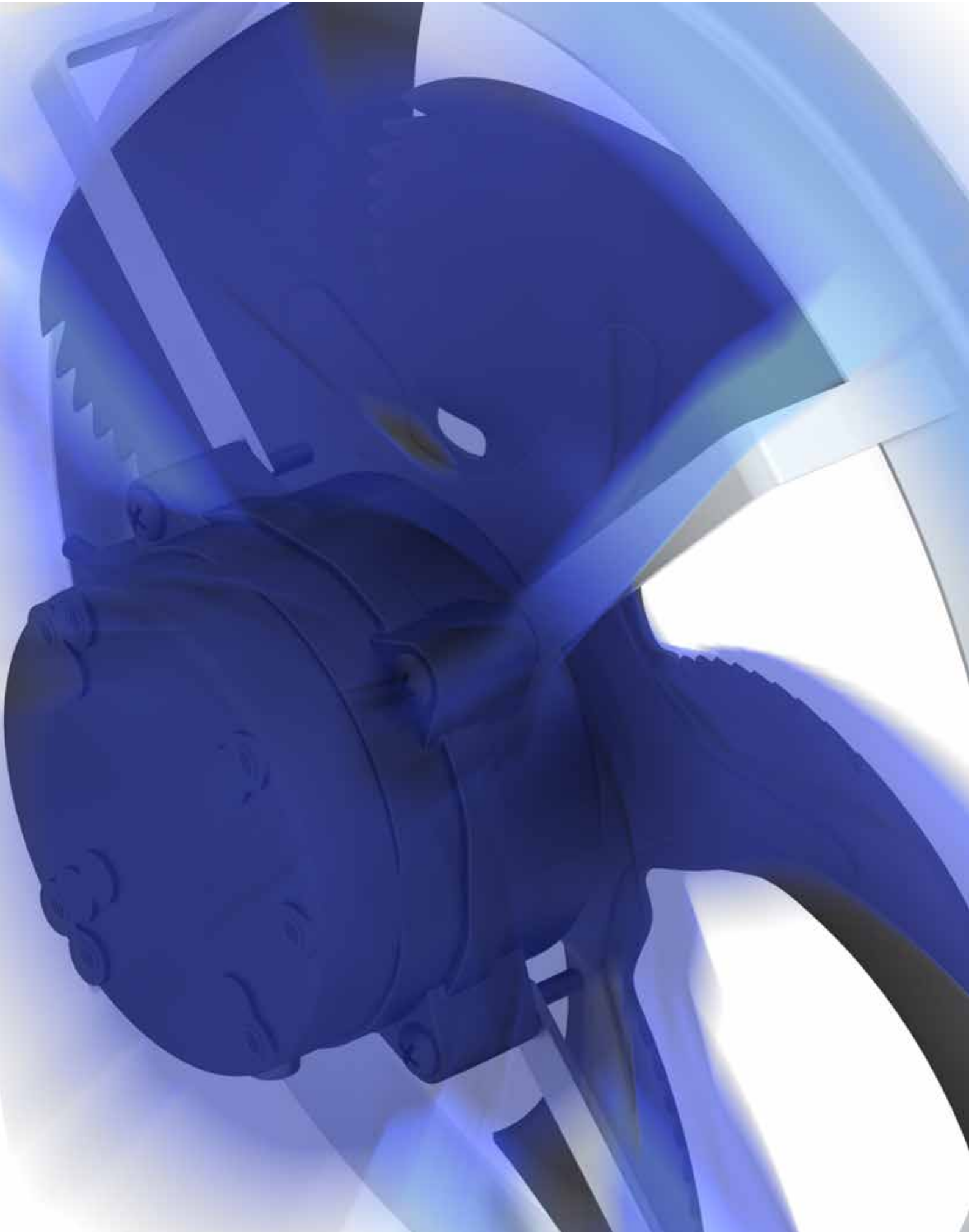

Axial fans FE2owlet-ECQ

Product overview

ECQ 1~ 230 V

Size 170 Page 12

Size 200 Page 16

Size 230 Page 20

Size 250 Page 24

Size 300 Page 28

ECQ 1~ 120 V

Size 170 Page 30

Size 200 Page 34

Size 230 Page 38

Size 250 Page 42

Size 300 Page 46

FE2owlet-ECQ

for single phase alternating current, 200-264 V

FNO17



Description

Motor technology: EC
 Rated voltage U: 1~ 200-264 V*
 Rated frequency f: 50/60 Hz*
 Motor input power P_{sys} : 0,01 kW*
 Rated current I: 0,12- 0,094 A*
 Rated speed n_{max} : 1750 Min⁻¹*
 Thermal class: THCL130*
 Min. permitted conveyor temperature $t_{R(min)}$: -40 °C
 Max. permitted conveyor temperature $t_{R(max)}$: 50 °C
 Electrical connection: Integrated controller with attached cable
 Number of blades: 5
 Protection class: IP55
 Blades: High Performance Composite Material, uncoated, black
 Conformity: CE, UL
ErP-data
 Not subject to the regulations of ErP directive ($P_1 < 125$ W)
 * Rated data

Characteristic curve

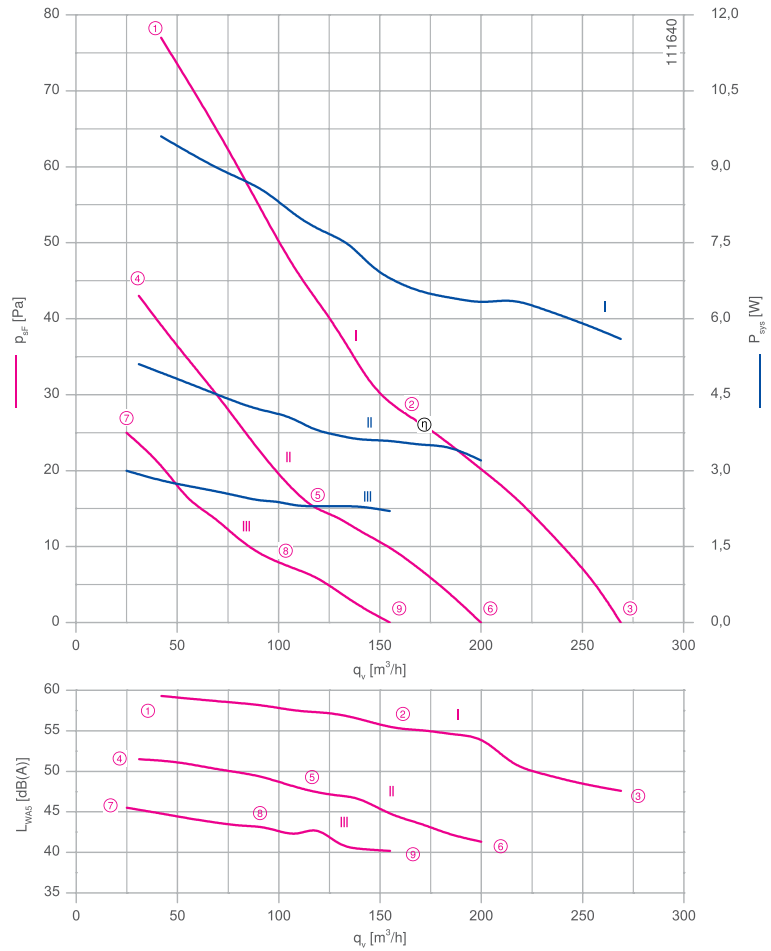

Measured with inlet ring, without guard grille in installation typet A according to ISO 5801

Connection diagram

Page 8
1360-334

Dimensions mm

Airflow direction V

Design A - without mounting

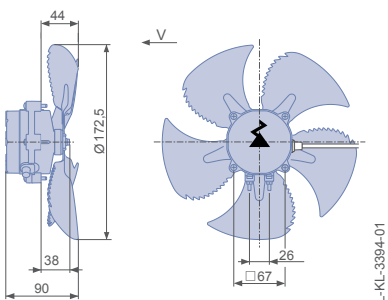

Design E - round short bell mouth, without guard grille

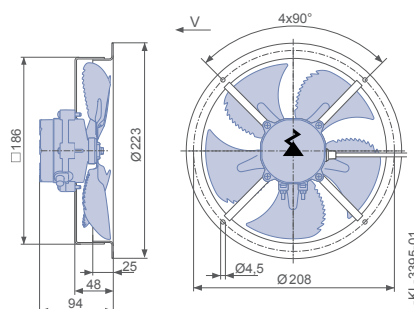

Performance data

Type	Characteristic curve	Speed n min ⁻¹	Operating point	Current	Motor input power	Suction side sound power level
				I A	P _{sys} W	L _{WA5} dB(A)
FN017-4Q_UA.V5P3	I	1750	①	0.10	10	59
			②	0.07	7	55
			③	0.06	6	48
	II	1300	④	0.05	5	52
			⑤	0.04	4	48
			⑥	0.03	3	41
	III	1000	⑦	0.03	3	46
			⑧	0.02	2	43
			⑨	0.02	2	40

Current values determined at 230V

Fan ordering information

Airflow direction V

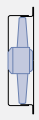
Design	A	E (without guard grille)
		
Type	FN017-4QA.UA.V5P3	FN017-4QE.UA.V5P3
Article no.	167989	151820
Weight kg	0.66	0.92

Control technology

Motor Programmer



Page 50

FE2owlet-ECQ

for single phase alternating current, 200-264 V

FNO17



Description

Motor technology: EC
 Rated voltage U: 1~ 200-264 V*
 Rated frequency f: 50/60 Hz*
 Motor input power P_{sys} : 0,016 kW*
 Rated current I: 0,20- 0,15 A*
 Rated speed n_{max} : 2200 Min⁻¹*
 Thermal class: THCL130*
 Min. permitted conveyor temperature $t_{R(min)}$: -40 °C
 Max. permitted conveyor temperature $t_{R(max)}$: 50 °C
 Electrical connection: Integrated controller with attached cable
 Number of blades: 5
 Protection class: IP55
 Blades: High Performance Composite Material, uncoated, black
 Conformity: CE, UL
ErP-data
 Not subject to the regulations of ErP directive ($P_1 < 125$ W)
 * Rated data

Characteristic curve

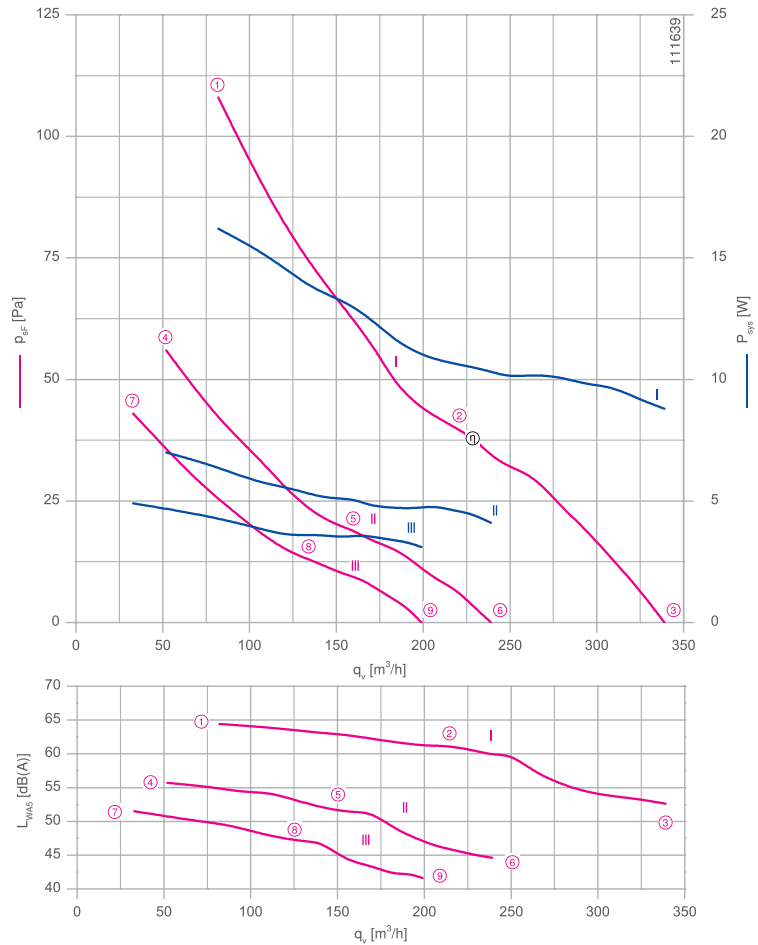

Measured with inlet ring, without guard grille in installation typet A according to ISO 5801

Connection diagram

Page 8
1360-334

Dimensions mm

Airflow direction V

Design A - without mounting

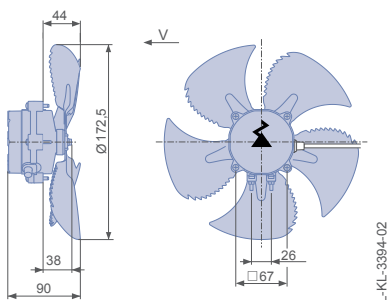

Design E - round short bell mouth, without guard grille

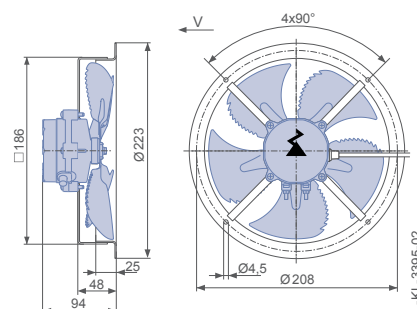



Performance data

Type	Characteristic curve	Speed n min ⁻¹	Operating point	Current	Motor input power	Suction side sound power level
				I A	P _{sys} W	L _{WA5} dB(A)
FN017-4Q_UA.V5P3	I	2200	①	0.17	16	64
			②	0.12	11	61
			③	0.09	9	53
	II	1550	④	0.07	7	56
			⑤	0.06	5	52
			⑥	0.04	4	45
	III	1300	⑦	0.05	5	52
			⑧	0.04	4	47
			⑨	0.03	3	42

Current values determined at 230V

Fan ordering information

Airflow direction V

Design	A	E (without guard grille)
		
Type	FN017-4QA.UA.V5P3	FN017-4QE.UA.V5P3
Article no.	167990	151821
Weight kg	0.66	0.92

Control technology

Motor Programmer



Page 50

FE2owlet-ECQ

for single phase alternating current, 200-264 V

FNO20



Description

Motor technology: EC
 Rated voltage U: 1~ 200-264 V*
 Rated frequency f: 50/60 Hz*
 Motor input power P_{sys} : 0,016 kW*
 Rated current I: 0,19- 0,145 A*
 Rated speed n_{max} : 1750 Min⁻¹*
 Thermal class: THCL130*
 Min. permitted conveyor temperature $t_{R(min)}$: -40 °C
 Max. permitted conveyor temperature $t_{R(max)}$: 50 °C
 Electrical connection: Integrated controller with attached cable
 Number of blades: 5
 Protection class: IP55
 Blades: High Performance Composite Material, uncoated, black
 Conformity: CE, UL
ErP-data
 Not subject to the regulations of ErP directive ($P_1 < 125$ W)
 * Rated data

Characteristic curve

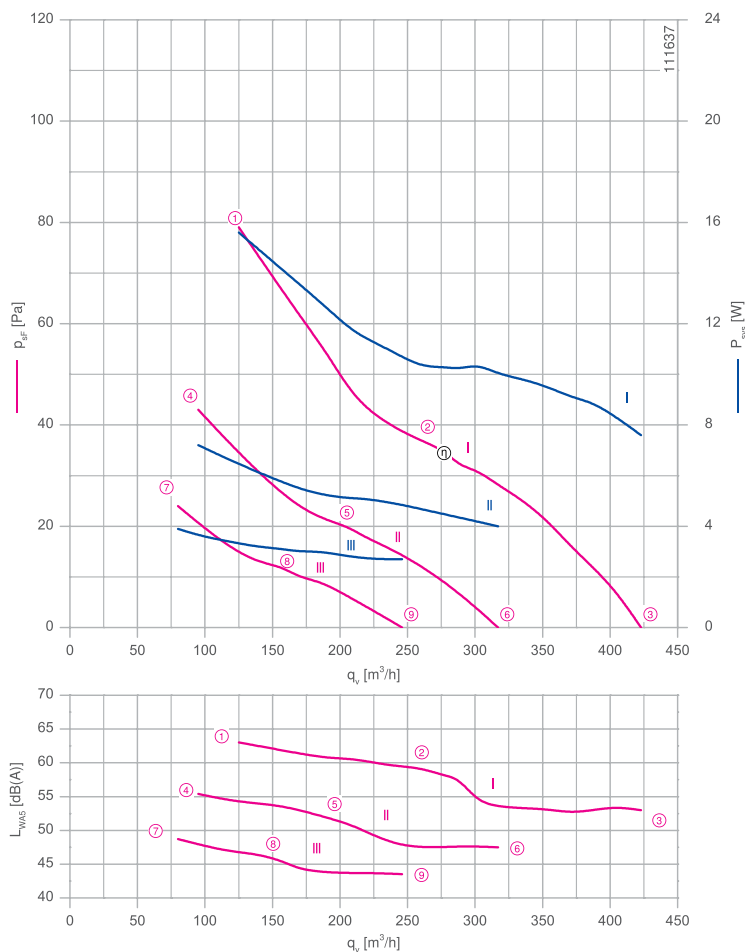

Measured with inlet ring, without guard grille in installation typet A according to ISO 5801

Connection diagram

Page 8
1360-334

Dimensions mm



Design A - without mounting

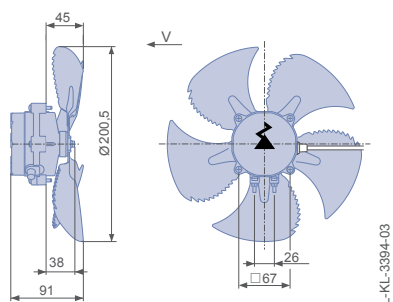

Design E - round short bell mouth, without guard grille

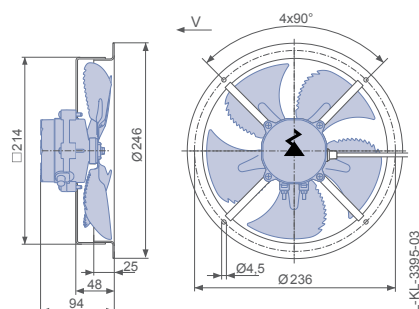

Performance data

Type	Characteristic curve	Speed n min ⁻¹	Operating point	Current	Motor input power	Suction side sound power level
				I A	P _{sys} W	L _{WA5} dB(A)
FN020-4Q_UA.V5P3	I	1750	①	0.16	16	63
			②	0.11	10	59
			③	0.08	8	53
	II	1300	④	0.08	7	55
			⑤	0.06	5	52
			⑥	0.04	4	48
	III	1000	⑦	0.04	4	49
			⑧	0.03	3	46
			⑨	0.01	1	44

Current values determined at 230V

Fan ordering information

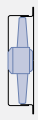
Airflow direction V		
Design	A	E (without guard grille)
		
Type	FN020-4QA.UA.V5P3	FN020-4QE.UA.V5P3
Article no.	167991	151822
Weight kg	0.67	0.95

Control technology

Motor Programmer



Page 50

FE2owlet-ECQ

for single phase alternating current, 200-264 V

FNO20



Description

Motor technology: EC
 Rated voltage U: 1~ 200-264 V*
 Rated frequency f: 50/60 Hz*
 Motor input power P_{sys} : 0,03 kW*
 Rated current I: 0,33- 0,25 A*
 Rated speed n_{max} : 2200 Min⁻¹*
 Thermal class: THCL130*
 Min. permitted conveyor temperature $t_{R(min)}$: -40 °C
 Max. permitted conveyor temperature $t_{R(max)}$: 50 °C
 Electrical connection: Integrated controller with attached cable
 Number of blades: 5
 Protection class: IP55
 Blades: High Performance Composite Material, uncoated, black
 Conformity: CE, UL
ErP-data
 Not subject to the regulations of ErP directive ($P_1 < 125$ W)
 * Rated data

Characteristic curve

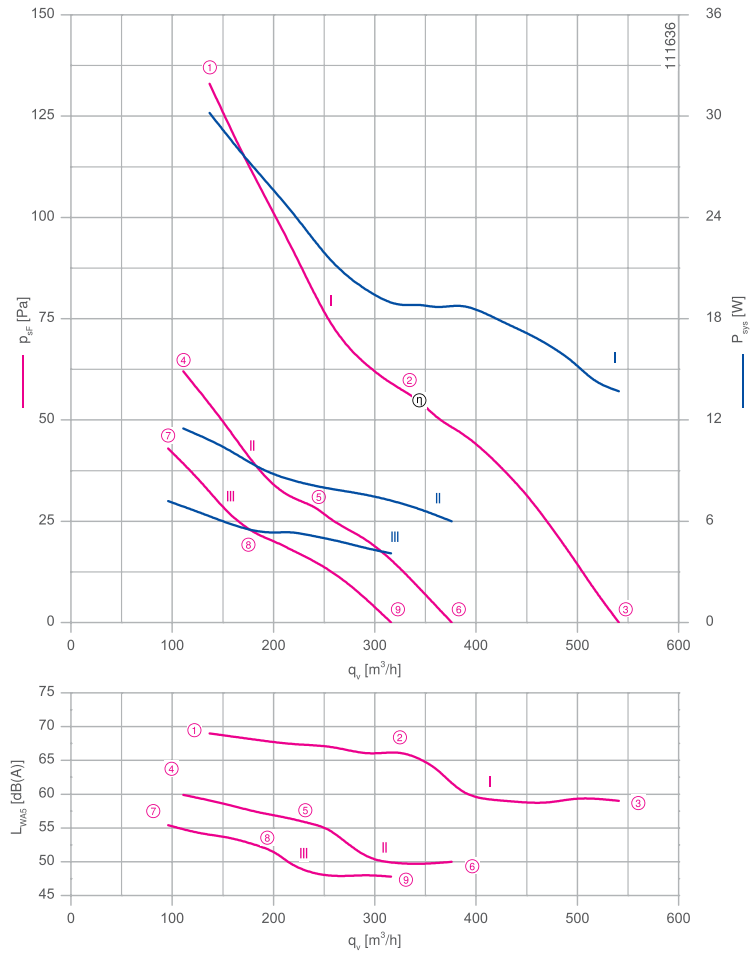

Measured with inlet ring, without guard grille in installation typet A according to ISO 5801

Connection diagram

Page 8
1360-334

Dimensions mm



Design A - without mounting

Design E - round short bell mouth, without guard grille

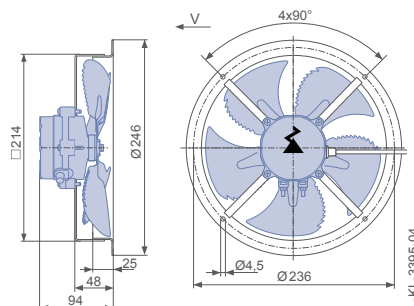
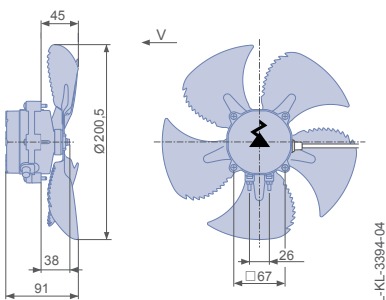

Performance data

Type	Characteristic curve	Speed n min ⁻¹	Operating point	Current	Motor input power	Suction side sound power level
				I A	P _{sys} W	L _{WA5} dB(A)
FN020-4Q_UA.V5P3	I	2200	①	0.29	30	69
			②	0.19	19	66
			③	0.14	14	59
	II	1550	④	0.12	12	60
			⑤	0.09	8	56
			⑥	0.06	6	50
	III	1300	⑦	0.08	7	55
			⑧	0.06	5	52
			⑨	0.04	4	48

Current values determined at 230V

Fan ordering information

Airflow direction V

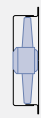
Design	A	E (without guard grille)
		
Type	FN020-4QA.UA.V5P3	FN020-4QE.UA.V5P3
Article no.	167992	151823
Weight kg	0.67	0.95

Control technology

Motor Programmer



Page 50

FE2owlet-ECQ

for single phase alternating current, 200-264 V

FN023



Description

Motor technology: EC
 Rated voltage U: 1~ 200-264 V*
 Rated frequency f: 50/60 Hz*
 Motor input power P_{sys} : 0,03 kW*
 Rated current I: 0,34- 0,26 A*
 Rated speed n_{max} : 1750 Min⁻¹*
 Thermal class: THCL130*
 Min. permitted conveyor temperature $t_{R(min)}$: -40 °C
 Max. permitted conveyor temperature $t_{R(max)}$: 50 °C
 Electrical connection: Integrated controller with attached cable
 Number of blades: 5
 Protection class: IP55
 Blades: High Performance Composite Material, uncoated, black
 Conformity: CE, UL
ErP-data
 Not subject to the regulations of ErP directive ($P_1 < 125$ W)
 * Rated data

Characteristic curve

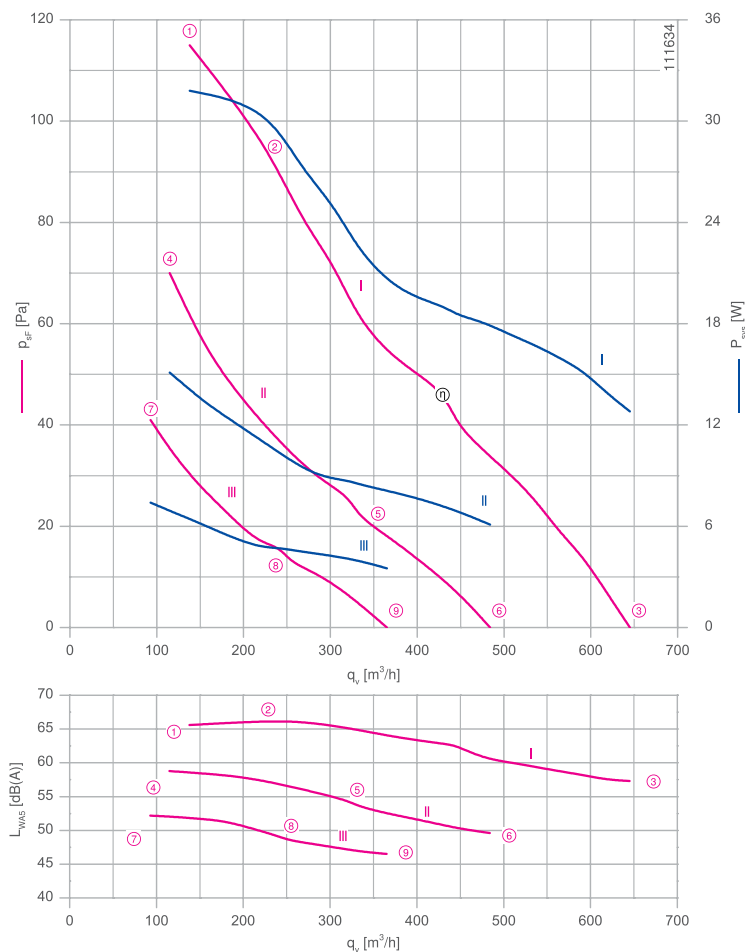

Measured with inlet ring, without guard grille in installation typet A according to ISO 5801

Connection diagram

Page 8
1360-334

Dimensions mm



Design A - without mounting

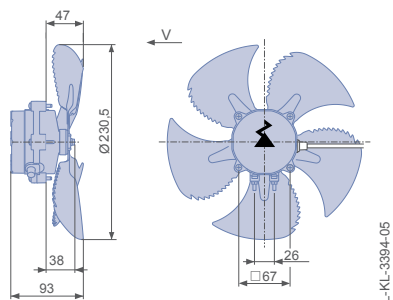

Design E - round short bell mouth, without guard grille

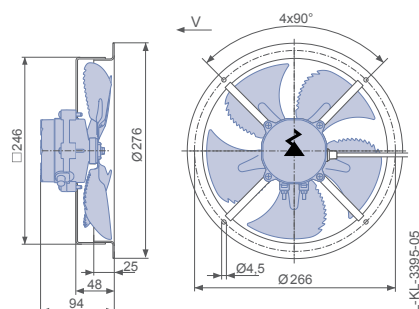

Performance data

Type	Characteristic curve	Speed n min ⁻¹	Operating point	Current I A	Motor input power P _{sys} W	Suction side sound power level L _{WA5} dB(A)
FN023-4Q_UA.V5P3	I	1750	①	0.30	32	66
			②	0.29	30	66
			③	0.14	13	57
	II	1300	④	0.17	15	60
			⑤	0.10	9	54
			⑥	0.07	6	50
	III	1000	⑦	0.08	7	52
			⑧	0.05	5	48
			⑨	0.04	4	47

Current values determined at 230V

Intelligent motor electronics limit the power consumption in operating point ①, where the full nominal speed is not reached.

Fan ordering information

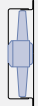
Airflow direction V		
Design	A	E (without guard grille)
		
Type	FN023-4QA.UA.V5P3	FN023-4QE.UA.V5P3
Article no.	167993	151824
Weight kg	0.69	1.01

Control technology

Motor Programmer



Page 50

FE2owlet-ECQ

for single phase alternating current, 200-264 V

FN023



Description

Motor technology: EC
 Rated voltage U: 1~ 200-264 V*
 Rated frequency f: 50/60 Hz*
 Motor input power P_{sys} : 0,034 kW*
 Rated current I: 0,36- 0,27 A*
 Rated speed n_{max} : 2200 Min⁻¹*
 Thermal class: THCL130*
 Min. permitted conveyor temperature $t_{R(min)}$: -40 °C
 Max. permitted conveyor temperature $t_{R(max)}$: 50 °C
 Electrical connection: Integrated controller with attached cable
 Number of blades: 5
 Protection class: IP55
 Blades: High Performance Composite Material, uncoated, black
 Conformity: CE, UL
ErP-data
 Not subject to the regulations of ErP directive ($P_1 < 125$ W)
 * Rated data

Characteristic curve

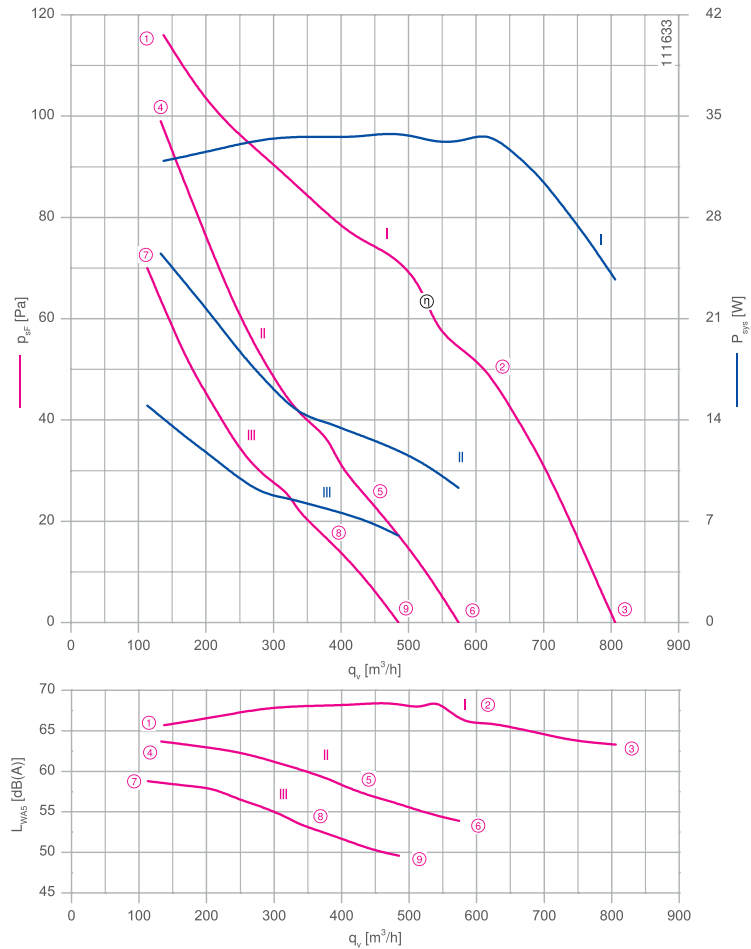

Connection diagram

Page 8
1360-334

Dimensions mm

Airflow direction V

Design A - without mounting

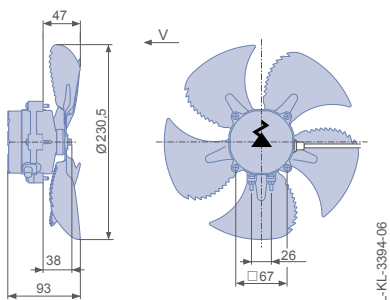

Design E - round short bell mouth, without guard grille

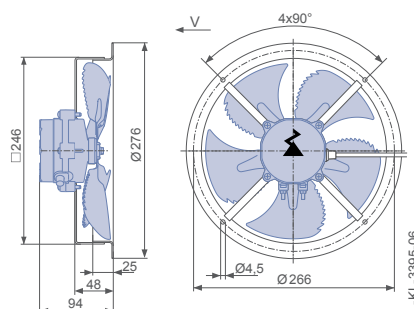

Performance data



Type	Characteristic curve	Speed n min ⁻¹	Operating point	Current	Motor input power	Suction side sound power level
				I A	P _{sys} W	L _{WA5} dB(A)
FN023-4Q_UA.V5P3	I	2200	①	0.30	32	66
			②	0.31	34	66
			③	0.24	24	63
	II	1550	④	0.25	26	64
			⑤	0.15	13	57
			⑥	0.11	9	54
	III	1300	⑦	0.16	15	60
			⑧	0.09	8	53
			⑨	0.07	6	50

Current values determined at 230V

Intelligent motor electronics limit the power consumption in operating point ① and ② ,where the full nominal speed is not reached.

Fan ordering information

Airflow direction V

Design	A	E (without guard grille)
		
Type	FN023-4QA.UA.V5P3	FN023-4QE.UA.V5P3
Article no.	167994	151825
Weight kg	0.69	1.01

Control technology

Motor Programmer



Page 50

FE2owlet-ECQ

for single phase alternating current, 200-264 V

FN025



Description

Motor technology: EC
 Rated voltage U: 1~ 200-264 V*
 Rated frequency f: 50/60 Hz*
 Motor input power P_{sys} : 0,032 kW*
 Rated current I: 0,34- 0,26 A*
 Rated speed n_{max} : 1750 Min⁻¹*
 Thermal class: THCL130*
 Min. permitted conveyor temperature $t_{R(min)}$: -40 °C
 Max. permitted conveyor temperature $t_{R(max)}$: 50 °C
 Electrical connection: Integrated controller with attached cable
 Number of blades: 5
 Protection class: IP55
 Blades: High Performance Composite Material, uncoated, black
 Conformity: CE, UL
ErP-data
 Not subject to the regulations of ErP directive ($P_1 < 125$ W)
 * Rated data

Characteristic curve

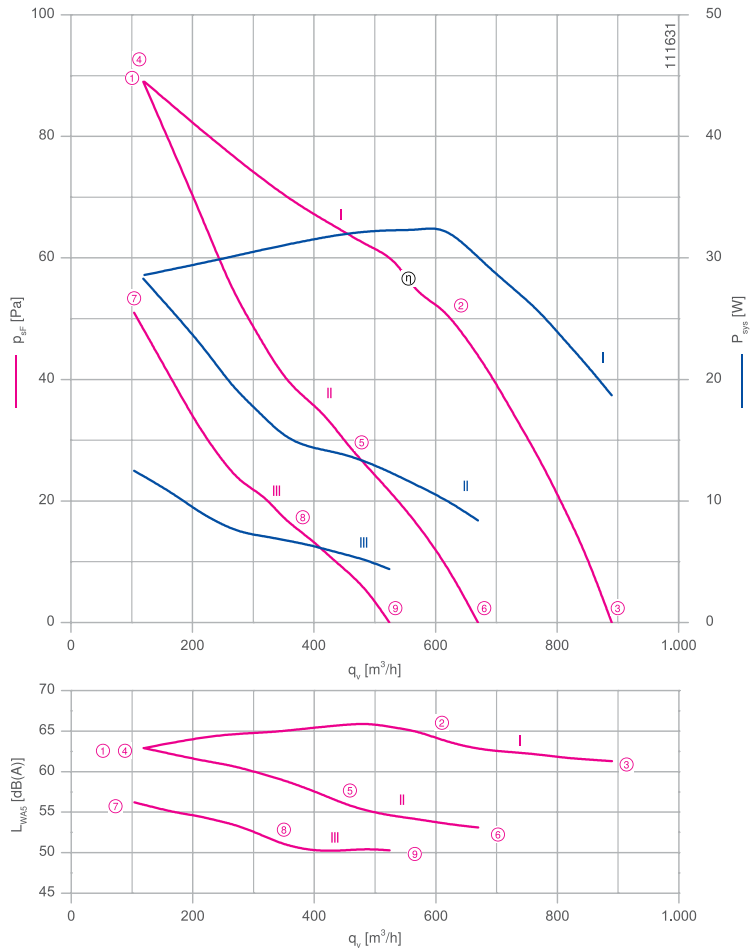

Measured with inlet ring, without guard grille in installation typet A according to ISO 5801

Connection diagram

Page 8
1360-334

Dimensions mm



Design A - without mounting

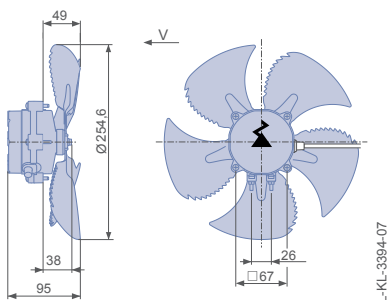

Design E - round short bell mouth, without guard grille

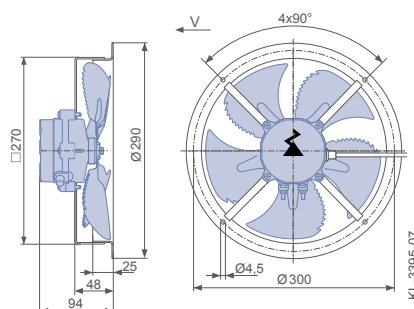

Performance data

Type	Characteristic curve	Speed n min ⁻¹	Operating point	Current	Motor input power	Suction side sound power level
				I A	P _{sys} W	L _{WA5} dB(A)
FN025-4Q_UA.V5P3	I	1750	①	0.27	28	63
			②	0.29	32	64
			③	0.18	19	61
	II	1300	④	0.28	28	63
			⑤	0.15	14	56
			⑥	0.09	8	53
	III	1000	⑦	0.14	13	56
			⑧	0.08	7	51
			⑨	0.05	4	50

Current values determined at 230V

Intelligent motor electronics limit the power consumption in operating point ① and ② ,where the full nominal speed is not reached.

Fan ordering information

Airflow direction V

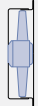
Design	A	E (without guard grille)
		
Type	FN025-4QA.UA.V5P3	FN025-4QE.UA.V5P3
Article no.	167995	151826
Weight kg	0.71	1.05

Control technology

Motor Programmer



Page 50

FE2owlet-ECQ

for single phase alternating current, 200-264 V

FN025



Description

Motor technology: EC
 Rated voltage U: 1~ 200-264 V*
 Rated frequency f: 50/60 Hz*
 Motor input power P_{sys} : 0,032 kW*
 Rated current I: 0,31- 0,27 A*
 Rated speed n_{max} : 1950 Min⁻¹*
 Thermal class: THCL130*
 Min. permitted conveyor temperature $t_{R(min)}$: -40 °C
 Max. permitted conveyor temperature $t_{R(max)}$: 50 °C
 Electrical connection: Integrated controller with attached cable
 Number of blades: 5
 Protection class: IP55
 Blades: High Performance Composite Material, uncoated, black
 Conformity: CE, UL
ErP-data
 Not subject to the regulations of ErP directive ($P_1 < 125$ W)
 * Rated data

Characteristic curve

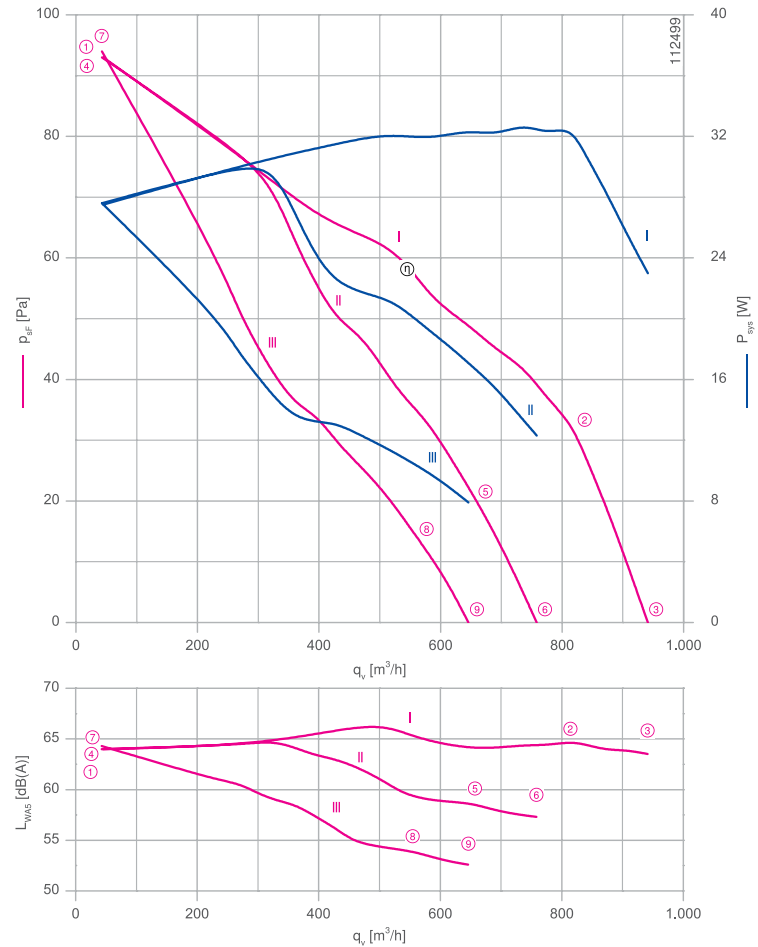

Measured with inlet ring, without guard grille in installation typet A according to ISO 5801

Connection diagram

Page 8
1360-334

Dimensions mm

Airflow direction V

Design A - without mounting

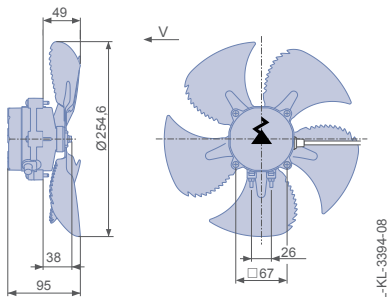

Design E - round short bell mouth, without guard grille

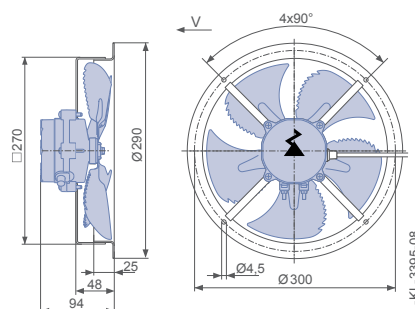



Performance data

Type	Characteristic curve	Speed n min ⁻¹	Operating point	Current	Motor input power	Suction side sound power level
				I A	P _{sys} W	L _{WA5} dB(A)
FN025-4Q_UA.V5P3	I	1950	①	0.27	28	64
			②	0.31	32	65
			③	0.24	24	64
	II	1550	④	0.27	28	64
			⑤	0.18	17	59
			⑥	0.14	12	57
	III	1300	⑦	0.26	28	64
			⑧	0.12	11	54
			⑨	0.09	8	53

Current values determined at 230V

Intelligent motor electronics limit the power consumption in operating point ① and ② ,where the full nominal speed is not reached.

Fan ordering information

Airflow direction V		
Design	A	E (without guard grille)
		
Type	FN025-4QA.UA.V5P3	FN025-4QE.UA.V5P3
Article no.	167996	151827
Weight kg	0.71	1.05

Control technology

Motor Programmer



Page 50

FE2owlet-ECQ

for single phase alternating current, 200-264 V

FNO30



Description

Motor technology: EC
 Rated voltage U: 1~ 200-264 V*
 Rated frequency f: 50/60 Hz*
 Motor input power P_{sys} : 0,028 kW*
 Rated current I: 0,31- 0,24 A*
 Rated speed n_{max} : 1300 Min⁻¹*
 Thermal class: THCL130*
 Min. permitted conveyor temperature $t_{R(min)}$: -40 °C
 Max. permitted conveyor temperature $t_{R(max)}$: 50 °C
 Electrical connection: Integrated controller with attached cable
 Number of blades: 5
 Protection class: IP55
 Blades: High Performance Composite Material, uncoated, black
 Conformity: CE, UL
ErP-data
 Not subject to the regulations of ErP directive ($P_1 < 125$ W)
 * Rated data

Characteristic curve

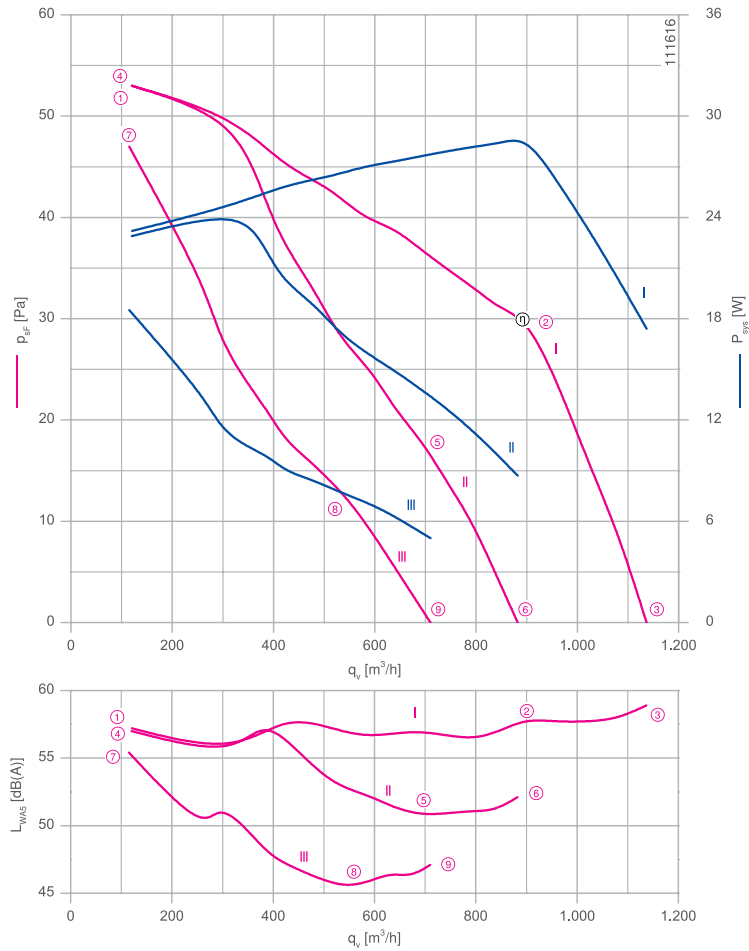

Measured with inlet ring, without guard grille in installation typet A according to ISO 5801

Connection diagram

Page 8
1360-334

Dimensions mm

Airflow direction V

Design A - without mounting

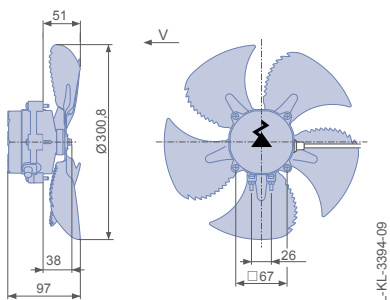

Design E - round short bell mouth, without guard grille

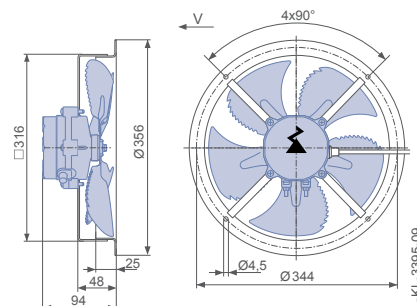

Performance data



Type	Characteristic curve	Speed n min ⁻¹	Operating point	Current	Motor input power	Suction side sound power level
				I A	P _{sys} W	L _{WA5} dB(A)
FN030-4Q_UA.V5P3	I	1300	①	0.23	24	57
			②	0.27	28	58
			③	0.18	17	59
	II	1000	④	0.24	22	57
			⑤	0.15	14	51
			⑥	0.10	9	52
	III	800	⑦	0.19	19	55
			⑧	0.08	7	46
			⑨	0.06	5	47

Current values determined at 230V

Intelligent motor electronics limit the power consumption in operating point ① and ② ,where the full nominal speed is not reached.

Fan ordering information

Airflow direction V

Design	A	E (without guard grille)
		
Type	FN030-4QA.UA.V5P3	FN030-4QE.UA.V5P3
Article no.	167997	151828
Weight kg	0.74	1.19

Control technology

Motor Programmer



Page 50

FE2owlet-ECQ

for single phase alternating current, 100-134 V

FNO17



Description

Motor technology: EC
 Rated voltage U: 1~ 100-134 V*
 Rated frequency f: 50/60 Hz*
 Motor input power P_{sys} : 10 W*
 Rated current I: 0.16- 0.12 A*
 Rated speed n_{max} : 1750 min⁻¹*
 Thermal class: THCL130*
 Min. permitted ambient temperature $t_{R(min)}$: -40 °C
 Max. permitted ambient temperature $t_{R(max)}$: 50 °C
 Electrical connection: Integrated controller with attached cable
 Number of blades: 5
 Protection class: IP55
 Blades: High Performance Composite Material, uncoated, black
 Conformity: CE, UL
ErP-data
 Not subject to the regulations of ErP directive ($P_1 < 125$ W)
 * Rated data

Characteristic curve

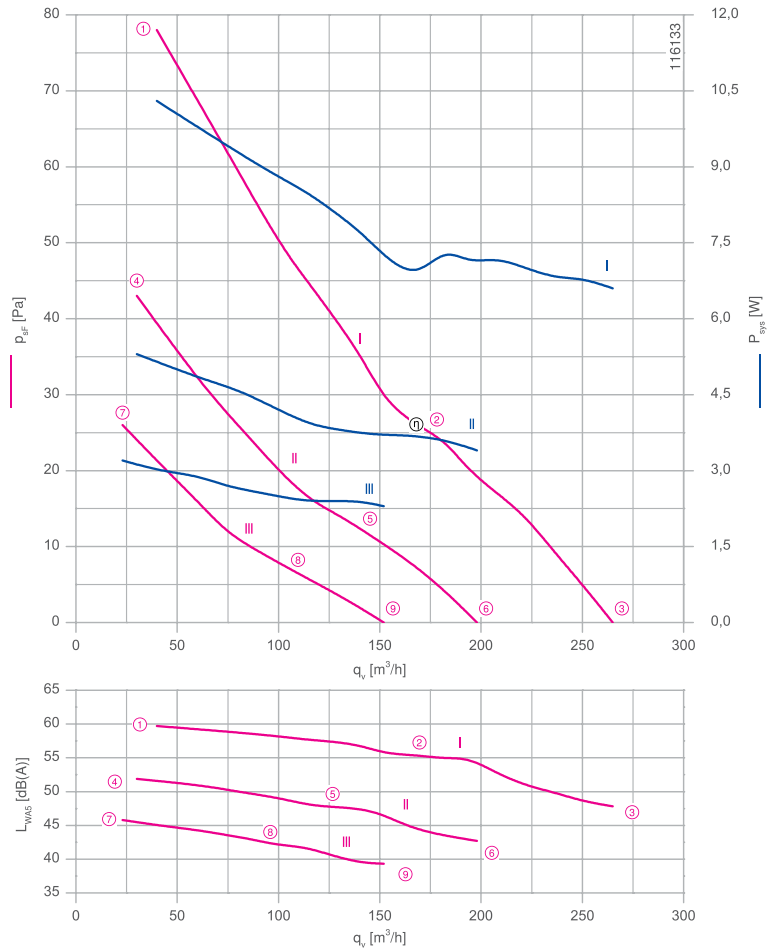

Measured with inlet ring, without guard grille in installation typet A according to ISO 5801

Connection diagram

Page 8
1360-334

Dimensions mm

Airflow direction V

Design A - without mounting

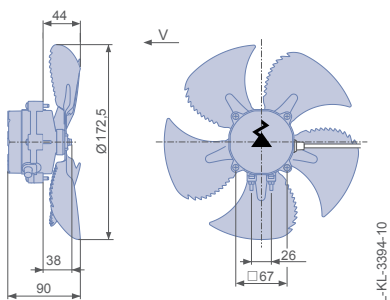

Design E - round short bell mouth, without guard grille

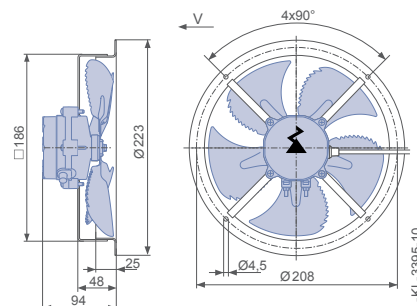

Performance data

Type	Characteristic curve	Speed n min ⁻¹	Operating point	Current	Motor input power	Suction side sound power level
				I A	P _{sys} W	L _{WA5} dB(A)
FN017-4Q_UA_5P3	I	1750	①	0.14	10	60
			②	0.09	7	55
			③	0.09	7	48
	II	1300	④	0.07	5	52
			⑤	0.05	4	48
			⑥	0.05	3	43
	III	1000	⑦	0.05	3	46
			⑧	0.04	3	42
			⑨	0.03	2	39

Current values determined at 115V

Fan ordering information

Airflow direction V

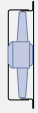
Design	A	E (without guard grille)
		
Type	FN017-4QA.UA.V5P3	FN017-4QE.UA.V5P3
Article no.	169782	169773
Weight kg	0.66	0.92

Control technology

Motor Programmer



Page 50

FE2owlet-ECQ

for single phase alternating current, 100-134 V

FNO17



Description

Motor technology: EC
 Rated voltage U: 1~ 100-134 V*
 Rated frequency f: 50/60 Hz*
 Motor input power P_{sys} : 18 W*
 Rated current I: 0.26- 0.195 A*
 Rated speed n_{max} : 2200 min⁻¹*
 Thermal class: THCL130*
 Min. permitted ambient temperature $t_{R(min)}$: -40 °C
 Max. permitted ambient temperature $t_{R(max)}$: 50 °C
 Electrical connection: Integrated controller with attached cable
 Number of blades: 5
 Protection class: IP55
 Blades: High Performance Composite Material, uncoated, black
 Conformity: CE, UL
ErP-data
 Not subject to the regulations of ErP directive ($P_1 < 125$ W)
 * Rated data

Characteristic curve

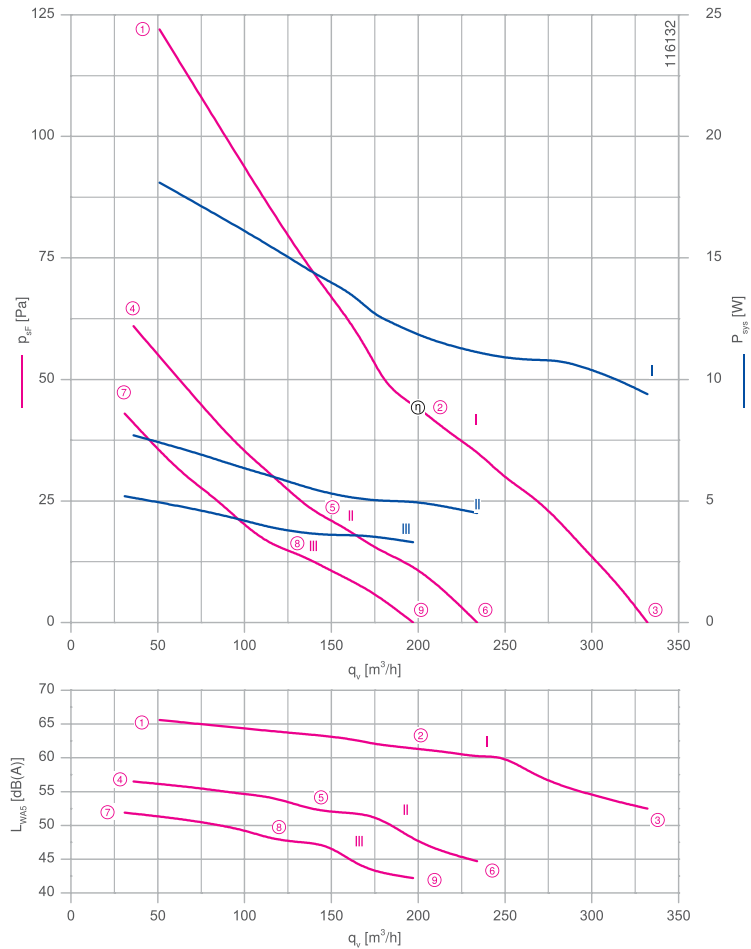

Measured with inlet ring, without guard grille in installation typet A according to ISO 5801

Connection diagram

Page 8
1360-334

Dimensions mm

Airflow direction V

Design A - without mounting

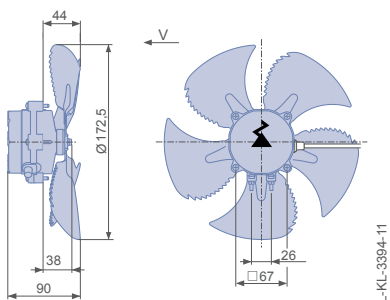

Design E - round short bell mouth, without guard grille

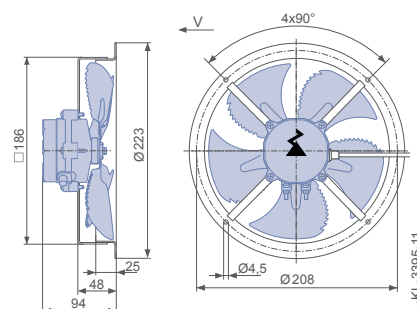

Performance data

Type	Characteristic curve	Speed n min ⁻¹	Operating point	Current	Motor input power	Suction side sound power level
				I A	P _{sys} W	L _{WA5} dB(A)
FN017-4Q_UA_5P3	I	2200	①	0.23	18	71
			②	0.15	12	61
			③	0.12	9	53
	II	1550	④	0.10	8	56
			⑤	0.07	5	52
			⑥	0.06	5	45
	III	1300	⑦	0.07	5	52
			⑧	0.05	4	48
			⑨	0.05	3	42

Current values determined at 115V

Fan ordering information

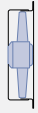
Airflow direction V		
Design	A	E (without guard grille)
		
Type	FN017-4QA.UA.V5P3	FN017-4QE.UA.V5P3
Article no.	169783	169774
Weight kg	0.66	0.92

Control technology

Motor Programmer



Page 50

FE2owlet-ECQ

for single phase alternating current, 100-134 V

FNO20



Description

Motor technology: EC
 Rated voltage U: 1~ 100-134 V*
 Rated frequency f: 50/60 Hz*
 Motor input power P_{sys} : 20 W*
 Rated current I: 0.29- 0.21 A*
 Rated speed n_{max} : 1750 min⁻¹*
 Thermal class: THCL130*
 Min. permitted ambient temperature $t_{R(min)}$: -40 °C
 Max. permitted ambient temperature $t_{R(max)}$: 50 °C
 Electrical connection: Integrated controller with attached cable
 Number of blades: 5
 Protection class: IP55
 Blades: High Performance Composite Material, uncoated, black
 Conformity: CE, UL
ErP-data
 Not subject to the regulations of ErP directive ($P_1 < 125$ W)
 * Rated data

Characteristic curve

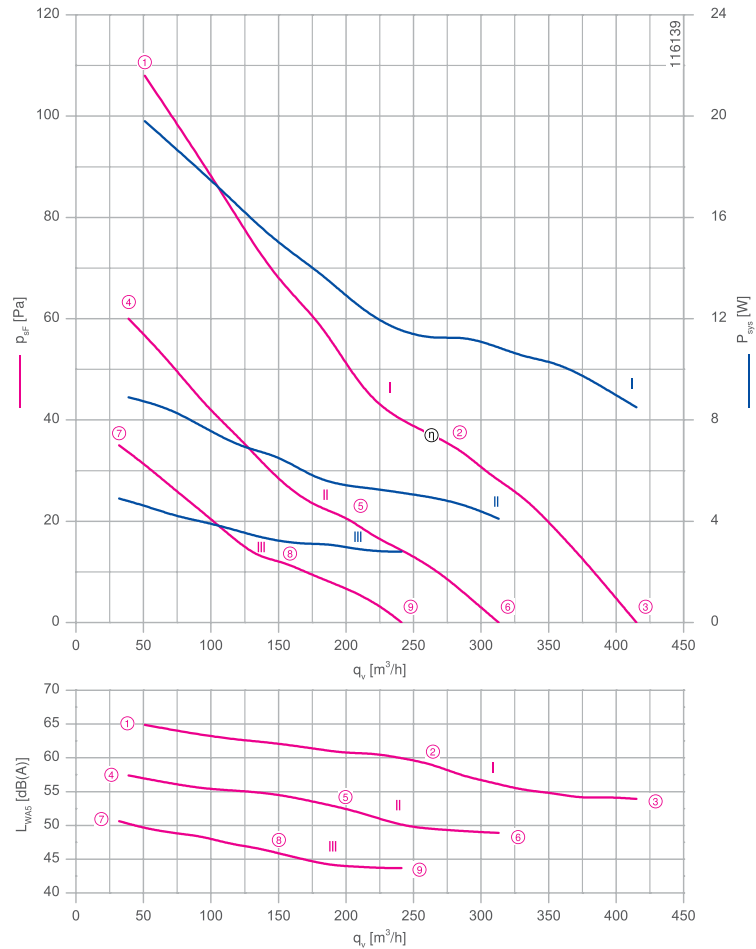

Measured with inlet ring, without guard grille in installation typet A according to ISO 5801

Connection diagram

Page 8
1360-334

Dimensions mm

Airflow direction V

Design A - without mounting

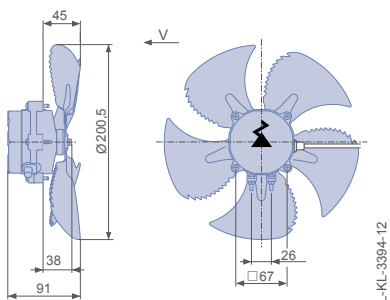

Design E - round short bell mouth, without guard grille

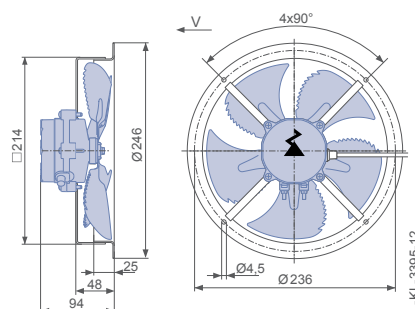



Performance data

Type	Characteristic curve	Speed	Operating point	Current	Motor input power	Suction side sound power level
		n min ⁻¹		I A	P _{sys} W	L _{WA5} dB(A)
FN020-4Q_UA_5P3	I	1750	①	0.25	20	65
			②	0.15	11	59
			③	0.11	9	54
	II	1300	④	0.12	9	57
			⑤	0.07	5	53
			⑥	0.06	4	49
	III	1000	⑦	0.07	5	51
			⑧	0.05	3	46
			⑨	0.04	3	44

Current values determined at 115V

Fan ordering information

Airflow direction V

Design	A	E (without guard grille)
		
Type	FN020-4QA.UA.V5P3	FN020-4QE.UA.V5P3
Article no.	169784	169775
Weight kg	0.67	0.95

Control technology

Motor Programmer



Page 50

FE2owlet-ECQ

for single phase alternating current, 100-134 V

FNO20



Description

Motor technology: EC
 Rated voltage U: 1~ 100-134 V*
 Rated frequency f: 50/60 Hz*
 Motor input power P_{sys} : 32 W*
 Rated current I: 0.44- 0.34 A*
 Rated speed n_{max} : 2200 min⁻¹*
 Thermal class: THCL130*
 Min. permitted ambient temperature $t_{R(min)}$: -40 °C
 Max. permitted ambient temperature $t_{R(max)}$: 50 °C
 Electrical connection: Integrated controller with attached cable
 Number of blades: 5
 Protection class: IP55
 Blades: High Performance Composite Material, uncoated, black
 Conformity: CE, UL
ErP-data
 Not subject to the regulations of ErP directive ($P_1 < 125$ W)
 * Rated data

Characteristic curve

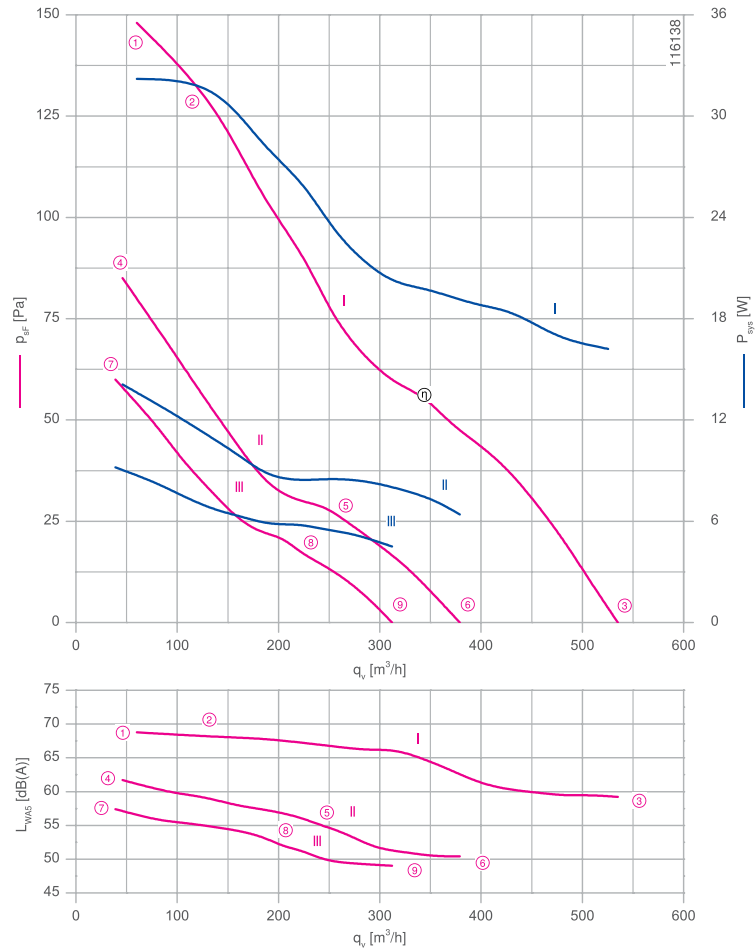

Measured with inlet ring, without guard grille in installation typet A according to ISO 5801

Connection diagram

Page 8
1360-334

Dimensions mm



Design A - without mounting

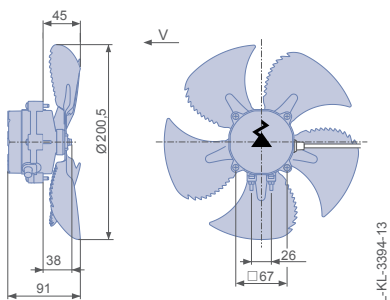

Design E - round short bell mouth, without guard grille

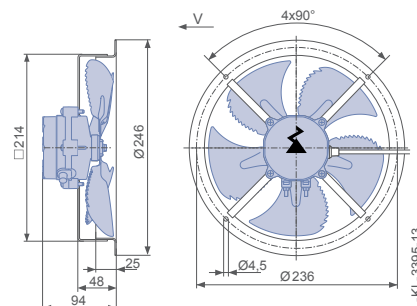



Performance data

Type	Characteristic curve	Speed n min ⁻¹	Operating point	Current	Motor input power	Suction side sound power level
				I A	P _{sys} W	L _{WA5} dB(A)
FN020-4Q_UA_5P3	I	2200	①	0.39	32	69
			②	0.39	32	68
			③	0.20	16	59
	II	1550	④	0.18	14	62
			⑤	0.11	9	55
			⑥	0.09	6	50
	III	1300	⑦	0.12	9	57
			⑧	0.08	6	52
			⑨	0.06	5	49

Current values determined at 115V

Fan ordering information

Airflow direction V		
Design	A	E (without guard grille)
		
Type	FN020-4QA.UA.V5P3	FN020-4QE.UA.V5P3
Article no.	169785	169776
Weight kg	0.67	0.95

Control technology

Motor Programmer



Page 50

FE2owlet-ECQ

for single phase alternating current, 100-134 V

FN023



Description

Motor technology: EC
 Rated voltage U: 1~ 100-134 V*
 Rated frequency f: 50/60 Hz*
 Motor input power P_{sys} : 30 W*
 Rated current I: 0.42- 0.31 A*
 Rated speed n_{max} : 1750 min⁻¹*
 Thermal class: THCL130*
 Min. permitted ambient temperature $t_{R(min)}$: -40 °C
 Max. permitted ambient temperature $t_{R(max)}$: 50 °C
 Electrical connection: Integrated controller with attached cable
 Number of blades: 5
 Protection class: IP55
 Blades: High Performance Composite Material, uncoated, black
 Conformity: CE, UL
ErP-data
 Not subject to the regulations of ErP directive ($P_1 < 125$ W)
 * Rated data

Characteristic curve

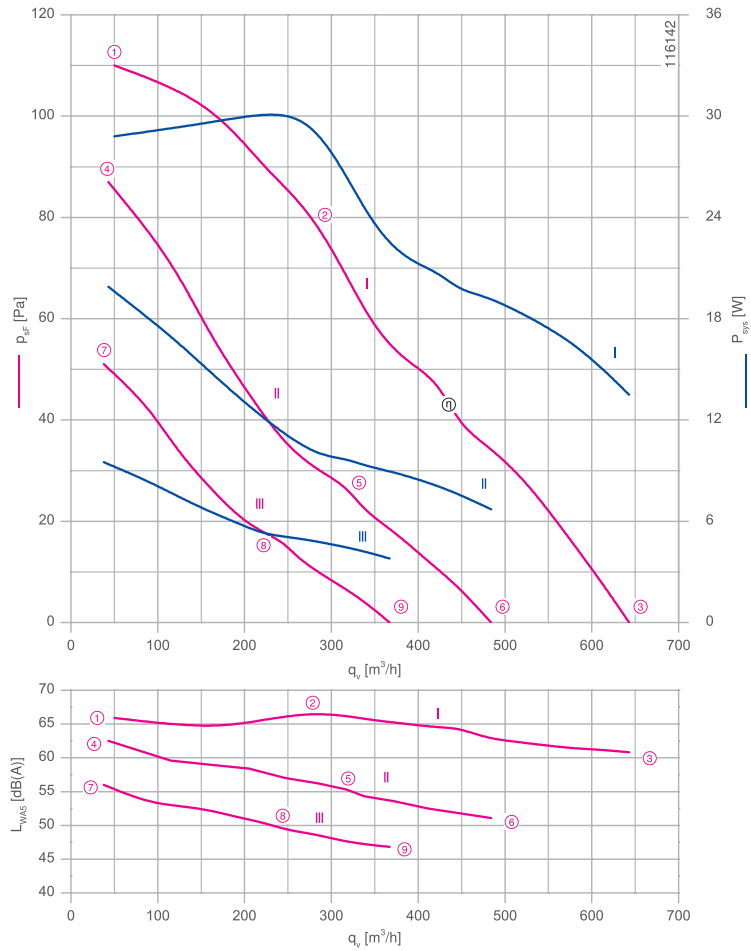

Measured with inlet ring, without guard grille in installation typet A according to ISO 5801

Connection diagram

Page 8
1360-334

Dimensions mm

Airflow direction V

Design A - without mounting

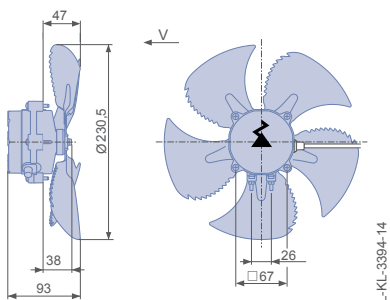

Design E - round short bell mouth, without guard grille

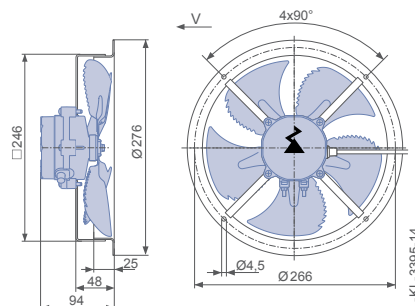

Performance data

Type	Characteristic curve	Speed n min ⁻¹	Operating point	Current	Motor input power	Suction side sound power level
				I A	P _{sys} W	L _{WA5} dB(A)
FN023-4Q_UA_5P3	I	1750	①	0.35	28	66
			②	0.36	30	67
			③	0.17	14	61
	II	1300	④	0.25	20	62
			⑤	0.13	10	55
			⑥	0.09	7	51
	III	1000	⑦	0.13	10	56
			⑧	0.07	5	50
			⑨	0.05	4	47

Current values determined at 115V

Intelligent motor electronics limit the power consumption in operating point ①, where the full nominal speed is not reached.

Fan ordering information

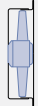
Airflow direction V		
Design	A	E (without guard grille)
		
Type	FN023-4QA.UA.V5P3	FN023-4QE.UA.V5P3
Article no.	169786	169777
Weight kg	0.69	1.01

Control technology

Motor Programmer



Page 50

FE2owlet-ECQ

for single phase alternating current, 100-134 V

FN023



Description

Motor technology: EC
 Rated voltage U: 1~ 100-134 V*
 Rated frequency f: 50/60 Hz*
 Motor input power P_{sys} : 32 W*
 Rated current I: 0.44- 0.33 A*
 Rated speed n_{max} : 2200 min⁻¹*
 Thermal class: THCL130*
 Min. permitted ambient temperature $t_{R(min)}$: -40 °C
 Max. permitted ambient temperature $t_{R(max)}$: 50 °C
 Electrical connection: Integrated controller with attached cable
 Number of blades: 5
 Protection class: IP55
 Blades: High Performance Composite Material, uncoated, black
 Conformity: CE, UL
ErP-data
 Not subject to the regulations of ErP directive ($P_1 < 125$ W)
 * Rated data

Characteristic curve

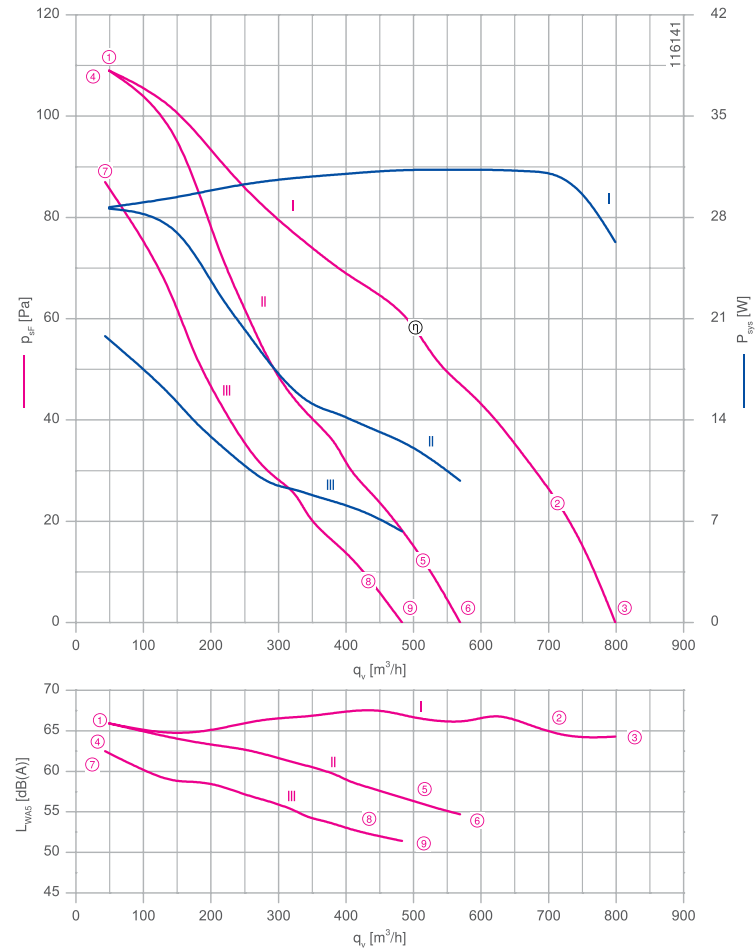

Measured with inlet ring, without guard grille in installation typet A according to ISO 5801

Connection diagram

Page 8
1360-334

Dimensions mm



Design A - without mounting

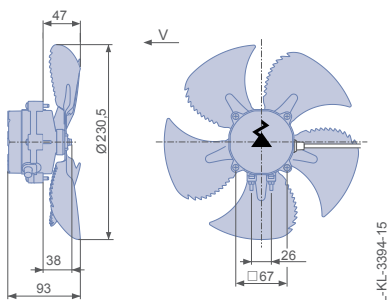

Design E - round short bell mouth, without guard grille

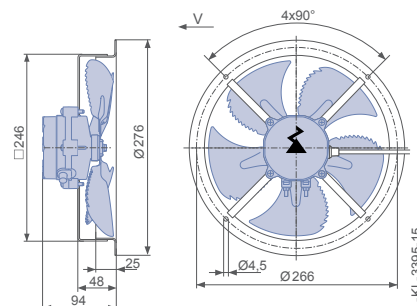

Performance data



Type	Characteristic curve	Speed n min ⁻¹	Operating point	Current	Motor input power	Suction side sound power level
				I A	P _{sys} W	L _{WA5} dB(A)
FN023-4Q_UA_5P3	I	2200	①	0.35	28	66
			②	0.38	32	65
			③	0.32	26	64
	II	1550	④	0.35	28	66
			⑤	0.15	12	56
			⑥	0.13	10	55
	III	1300	⑦	0.25	20	62
			⑧	0.10	8	52
			⑨	0.09	6	51

Current values determined at 115V

Intelligent motor electronics limit the power consumption in operating point ① and ② ,where the full nominal speed is not reached.

Fan ordering information

Airflow direction V

Design	A	E (without guard grille)
		
Type	FN023-4QA.UA.V5P3	FN023-4QE.UA.V5P3
Article no.	169787	169778
Weight kg	0.69	1.01

Control technology

Motor Programmer



Page 50

FE2owlet-ECQ

for single phase alternating current, 100-134 V

FN025



Description

Motor technology: EC
 Rated voltage U: 1~ 100-134 V*
 Rated frequency f: 50/60 Hz*
 Motor input power P_{sys} : 32 W*
 Rated current I: 0.44- 0.33 A*
 Rated speed n_{max} : 1750 min⁻¹*
 Thermal class: THCL130*
 Min. permitted ambient temperature $t_{R(min)}$: -40 °C
 Max. permitted ambient temperature $t_{R(max)}$: 50 °C
 Electrical connection: Integrated controller with attached cable
 Number of blades: 5
 Protection class: IP55
 Blades: High Performance Composite Material, uncoated, black
 Conformity: CE, UL
ErP-data
 Not subject to the regulations of ErP directive ($P_1 < 125$ W)
 * Rated data

Characteristic curve

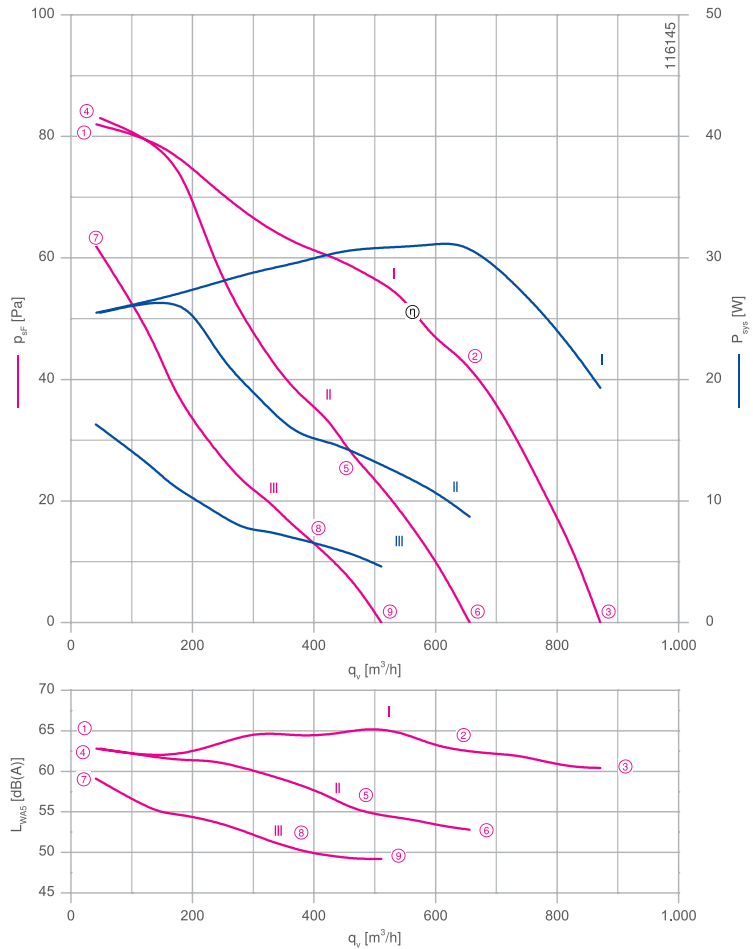

Measured with inlet ring, without guard grille in installation typet A according to ISO 5801

Connection diagram

Page 8
1360-334

Dimensions mm



Design A - without mounting

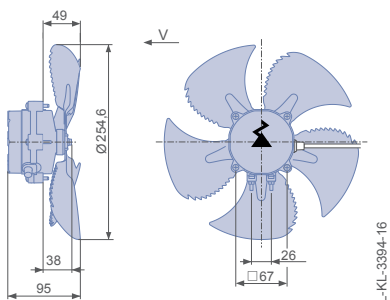

Design E - round short bell mouth, without guard grille

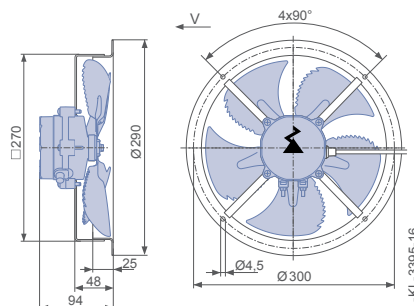

Performance data



Type	Characteristic curve	Speed n min ⁻¹	Operating point	Current	Motor input power	Suction side sound power level
				I A	P _{sys} W	L _{WA5} dB(A)
FN025-4Q_UA_5P3	I	1750	①	0.32	26	63
			②	0.38	32	63
			③	0.24	19	60
	II	1300	④	0.32	26	63
			⑤	0.17	14	55
			⑥	0.12	9	53
	III	1000	⑦	0.21	16	59
			⑧	0.09	7	50
			⑨	0.07	5	49

Current values determined at 115V

Intelligent motor electronics limit the power consumption in operating point ① and ② ,where the full nominal speed is not reached.

Fan ordering information

Airflow direction V

Design	A	E (without guard grille)
		
Type	FN025-4QA.UA.V5P3	FN025-4QE.UA.V5P3
Article no.	169788	169779
Weight kg	0.71	1.05

Control technology

Motor Programmer



Page 50

FE2owlet-ECQ

for single phase alternating current, 100-134 V

FN025



Description

Motor technology: EC
 Rated voltage U: 1~ 100-134 V*
 Rated frequency f: 50/60 Hz*
 Motor input power P_{sys} : 34 W*
 Rated current I: 0.46- 0.34 A*
 Rated speed n_{max} : 1950 min⁻¹*
 Thermal class: THCL130*
 Min. permitted ambient temperature $t_{R(min)}$: -40 °C
 Max. permitted ambient temperature $t_{R(max)}$: 50 °C
 Electrical connection: Integrated controller with attached cable
 Number of blades: 5
 Protection class: IP55
 Blades: High Performance Composite Material, uncoated, black
 Conformity: CE, UL
ErP-data
 Not subject to the regulations of ErP directive ($P_1 < 125$ W)
 * Rated data

Characteristic curve

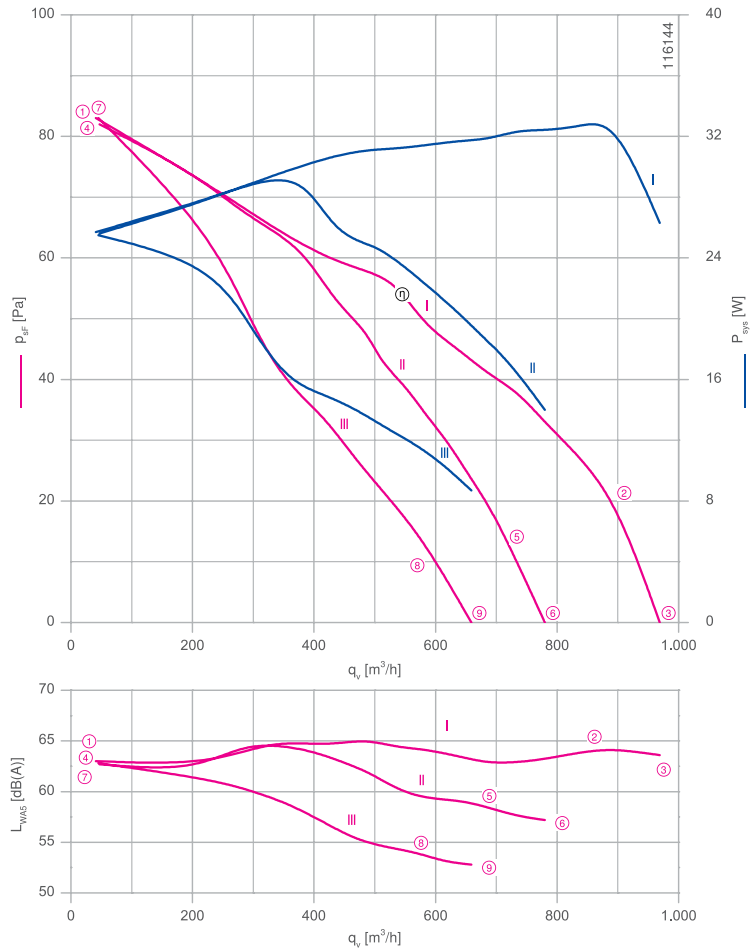

Measured with inlet ring, without guard grille in installation typet A according to ISO 5801

Connection diagram

Page 8
1360-334

Dimensions mm

Airflow direction V

Design A - without mounting

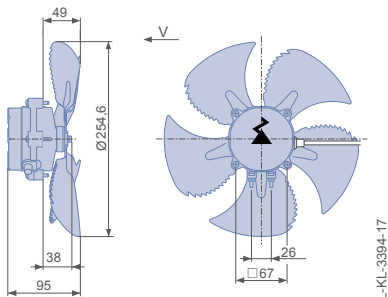

Design E - round short bell mouth, without guard grille

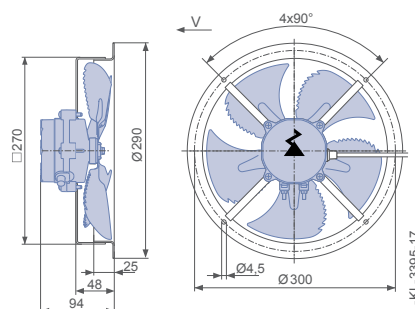



Performance data

Type	Characteristic curve	Speed n min ⁻¹	Operating point	Current	Motor input power	Suction side sound power level
				I A	P _{sys} W	L _{WA5} dB(A)
FN025-4Q_UA_5P3	I	1950	①	0.32	26	63
			②	0.40	34	64
			③	0.32	26	64
	II	1550	④	0.32	26	63
			⑤	0.22	17	58
			⑥	0.18	14	57
	III	1300	⑦	0.32	26	63
			⑧	0.14	11	53
			⑨	0.12	9	53

Current values determined at 115V

Intelligent motor electronics limit the power consumption in operating point ① and ② ,where the full nominal speed is not reached.

Fan ordering information

Airflow direction V		
Design	A	E (without guard grille)
		
Type	FN025-4QA.UA.V5P3	FN025-4QE.UA.V5P3
Article no.	169789	169780
Weight kg	0.71	1.05

Control technology

Motor Programmer



Page 50

FE2owlet-ECQ

for single phase alternating current, 100-134 V

FNO30



Description

Motor technology: EC
 Rated voltage U: 1~ 100-134 V*
 Rated frequency f: 50/60 Hz*
 Motor input power P_{sys} : 28 W*
 Rated current I: 0.39- 0.29 A*
 Rated speed n_{max} : 1300 min⁻¹*
 Thermal class: THCL130*
 Min. permitted ambient temperature $t_{R(min)}$: -40 °C
 Max. permitted ambient temperature $t_{R(max)}$: 50 °C
 Electrical connection: Integrated controller with attached cable
 Number of blades: 5
 Protection class: IP55
 Blades: High Performance Composite Material, uncoated, black
 Conformity: CE, UL
ErP-data
 Not subject to the regulations of ErP directive ($P_1 < 125$ W)
 * Rated data

Characteristic curve

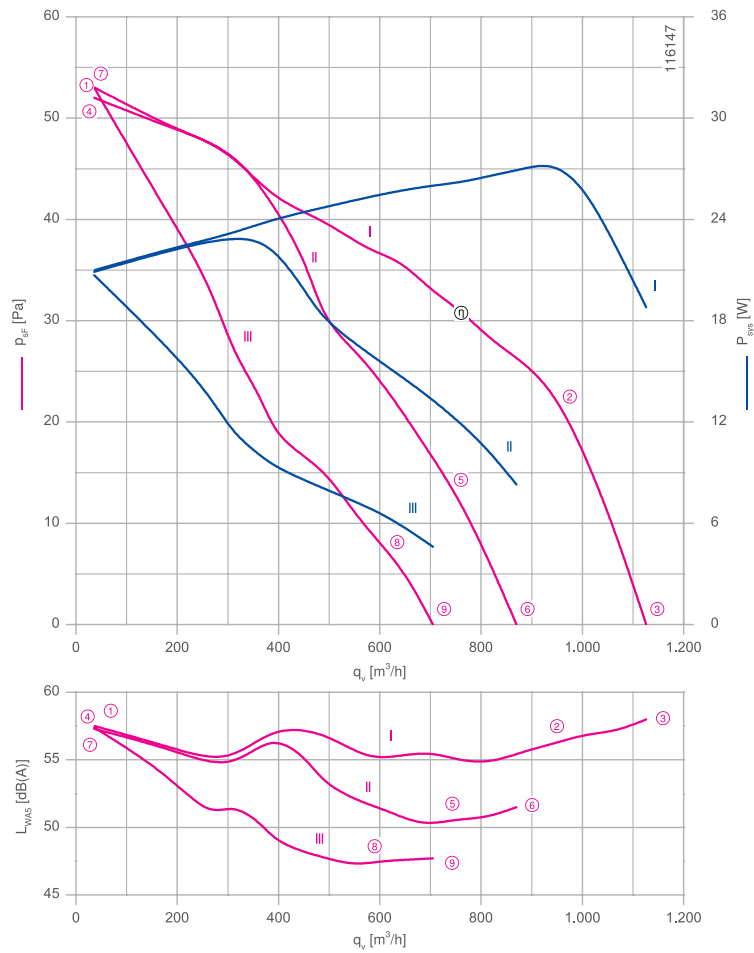

Measured with inlet ring, without guard grille in installation typet A according to ISO 5801

Connection diagram

Page 8
1360-334

Dimensions mm

Airflow direction V

Design A - without mounting

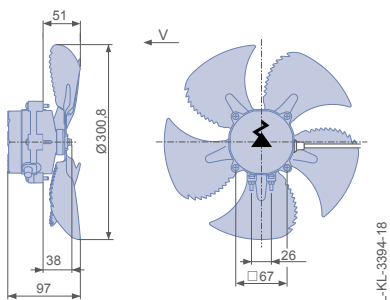

Design E - round short bell mouth, without guard grille

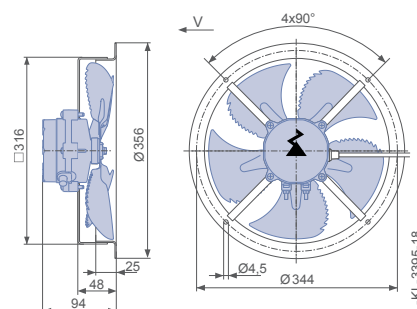



Performance data

Type	Characteristic curve	Speed n min ⁻¹	Operating point	Current	Motor input power	Suction side sound power level
				I A	P _{sys} W	L _{WA5} dB(A)
FN030-4Q_UA_5P3	I	1300	①	0.27	22	57
			②	0.34	28	56
			③	0.24	19	58
	II	1000	④	0.27	20	57
			⑤	0.16	13	51
			⑥	0.11	8	52
	III	800	⑦	0.27	20	57
			⑧	0.09	7	47
			⑨	0.07	5	48

Current values determined at 115V

Intelligent motor electronics limit the power consumption in operating point ① and ② ,where the full nominal speed is not reached.

Fan ordering information

Airflow direction V		
Design	A	E (without guard grille)
		
Type	FN030-4QA.UA.V5P3	FN030-4QE.UA.V5P3
Article no.	169790	169781
Weight kg	0.74	1.19

Control technology

Motor Programmer



Page 50



Control technology

Control technology

Motor Programmer

Page 50

Motor Programmer



ECQ motors can be adapted to individual requirements at any time. Speeds and turning direction can be reprogrammed with a computer.

The motor programmer serves to communicate between motor electronics and computer software. All the necessary cable are included in delivery.

Hardware drivers and software can be found under the following Internet address:
http://ziehl-abegg.com/ECQ_configurator

Article No. 00534239

Connection

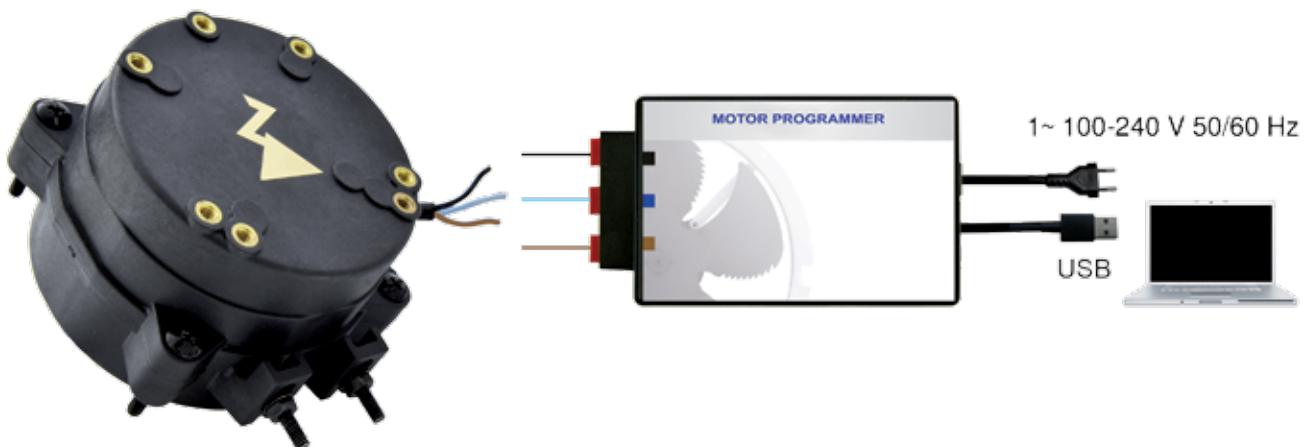



General notes

overview

Explanation of technical details	Page 54
Aerodynamics and Acoustics	Page 55
Installation and usage information	Page 58
ZIEHL-ABEGG global	Page 60

Explanation of technical details

Symbols, Units of Measure

Symbol	Unit	Description
P_{sF}	Pa	Static pressure increase
P_{d2}	Pa	Dynamic pressure
q_v	m ³ /h	Air flow
n_N	rpm	Rated speed
P_1	hp	Motor input power
P_{sys}	hp	Motor input power
U_N	V	Rated voltage
f_N	Hz	Rated frequency
I_N	A	Rated current
I_A	A	Starting current
ΔI	%	Percentage increase of current based on rated current for speed control by voltage reduction
C_{400V}	μF	Capacity
$t_{R(min)}$	°F	Minimum permitted conveyor temperature
$t_{R(max)}$	°F	Maximum permitted conveyor temperature
L_{WA5}	dB	Suction side sound power level
η_{statA}	%	Overall efficiency, static according to measurement category A at optimum duty point without losses of electronic speed control according to calculation method ErP-commission regulation No. 327/2011 annex II
N_{actual}	-	Actual efficiency grade of the fan based on an electrical input power of 10 kW at its point of optimum energy efficiency
N_{target}	-	Target efficiency grade at motor input power 10 kW
L_{pA}	dB	Suction-side or pressure-side acoustic pressure level
P_{spez}	Wh/1000m ³	Specific power

Conversion factors

Pressure

		SI-unit	Additional units		
		Pa (N/m ²)	mbar	in.wg	psi (lbs./in ²)
SI-unit	Pa (N/m ²)	1	0.01	0.004015	0.000145
Additional units	mbar	100	1	0.401463	0.014503
	in.wg	249.10	2.49	1	0.036127
	psi (lbs./in ²)	6894.76	68.95	27.68	1

Air flow

		SI-unit	Additional units		
		m ³ /s	m ³ /h	l/s	cfm
SI-unit	m ³ /s	1	3600	1000	2118.9
Additional units	m ³ /h	0.000277	1	0.277777	0.588583
	l/s	0.001	3.6	1	2.1189
	cfm	0.000472	1.698994	0.471943	1

Temperature

		SI-unit	Additional units
		°C	°F
SI-unit	°C	1	(°C × 1.8) + 32
Additional units	°F	(°F – 32) / 1.8	1



Aerodynamics and Acoustics

Measurement method

The characteristic map display shows the pressure increase Δp_{sF} in Pa as a function of the volume flow rate q_v in m^3/h .

Technical conditions of supply

The specified performance data meet the requirements for accuracy class 3 in line with **DIN 24 166** and apply to the rated data and air performance curves at the rated voltage. The continuous line in the characteristic map represents the optimum reliable operating range for axial fans.

Fan test bench

FE2owlet-ECblue, FE2owlet, MAXvent owlet:

The fan characteristic curves are determined on a combined ventilation and sound test bench.

The characteristic curves are measured in compliance with **DIN EN ISO 5801** and **AMCA 210-99**. The sound power levels are measured in compliance with **DIN EN ISO 3745** and **ISO 13347-3** using the enveloping surface measuring method

The figure below shows an example of the measuring setup. The fan intake is installed in the measuring chamber at free intake and free exhaust (installation type A as per **DIN EN ISO 5801** or **AMCA 210-99**).

Air density

The air density and humidity are conditioned during the measurement using heat exchangers and kept largely constant. The characteristic curves shown refer to the measuring density. The mean measuring density is 1.16 kg/m^3 .

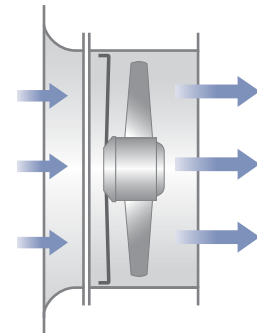

KL-1290a

Installation type A according to ISO 5801



Technology Centre (InVent)

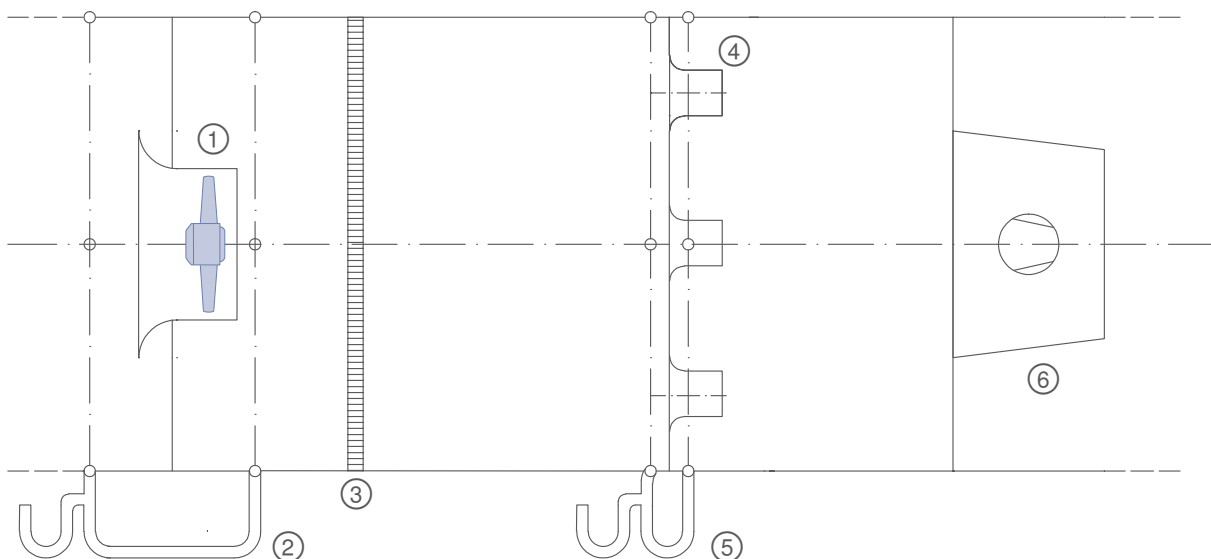

- ① Test fan
- ② P_{sF}
- ③ Flow straightener
- ④ Nozzles
- ⑤ Δp Differential pressure
- ⑥ Auxiliary fan

Noise level data

Unless otherwise indicated, this catalogue specifies the intake side, A-evaluated sound power levels L_{WA} . The sound power levels are determined by using the enveloping surface method in compliance with ISO 13347-3, accuracy class 1 and/or DIN EN ISO 3745.

This is done by measuring the acoustic pressure level L_p of the individual third-octave bands at 12 points on the enveloping surface (Fig. 1a). The measured acoustic pressure levels for the third-octave bands are initially used to calculate the sound power level for the third-octave bands and then the intake side sound power level L_W . To do this, the fans are installed with a free intake (from the measuring chamber) and an (air) outlet (into the surrounding area). The standard measurements are carried out without the need for additional parts, e.g. guard grille. The measuring equipment used complies with DIN EN 61672.

Because of the different weighting of the third-octave sound power level, the A-evaluation, which is typically carried out, takes into account the subjective nature of human sound perception. The A-weighted sound power level is the standard variable used to assess the sound characteristics of technical equipment.

Calculation of pressure side sound power level and total sound power level

For axial fans, the pressure side sound power level is approximately equal to the intake side level. The total sound power level is calculated by adding up the power from the sound power levels of both the intake and the pressure side (see DIN 45 635 Part 1, Appendix F, DIN EN ISO 3745). Thus, it is approximately 3 dB higher than the intake side sound power level specified in the catalogue.

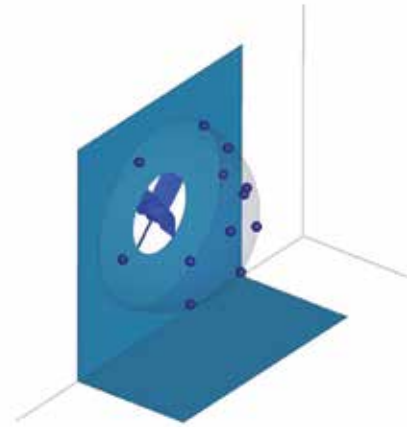

Fig. 1a: Position of microphones in relation to axial fans



Fig. 1b: Fan test-bench

Determination of total sound power level during the interaction of several sound sources

The total sound power level of several individual sound sources operating concurrently is calculated by adding the power of the individual levels in compliance with DIN EN ISO 3745. This equation is the basis for the diagrams in Fig. II and III.

To add up several sound sources with the same level, please see diagram (Fig. II) for complete level information; e.g. 6 identical sound sources operating concurrently results in a total level that is approx. 8 dB higher.

The total sound power level of two sound sources with different levels can be seen in diagram Fig. III. For example, two sound sources whose sound power levels differ by 4 dB produce a total sound power level that is around 1.5 dB higher than that of the louder sound source.

Determination of acoustic pressure level

The A-tested acoustic pressure level L_pA for rooms with average absorption capacity for a distance of 1m from the fan axis is calculated by subtracting 7 dB from the A sound power level L_{WA} . In most cases, this assumption is correct and provides a sufficient level of accuracy. However, the sound characteristics can be hugely influenced by the individual installation situation.

Absorption of the acoustic pressure level, depending on the distance with partial reflection, is shown in Fig. IV.

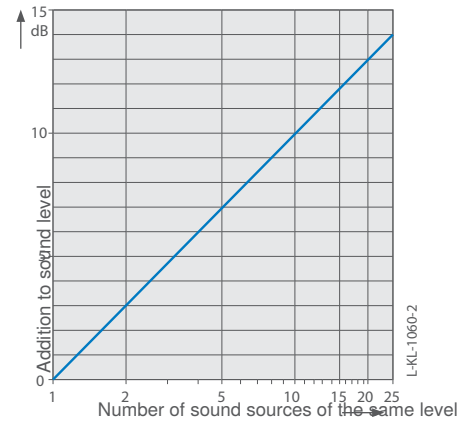

Fig. II: Addition of several sound sources

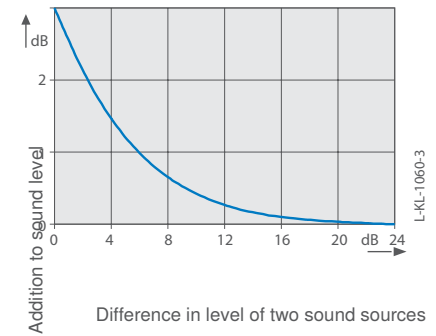

Fig. III: Sound sources of different levels

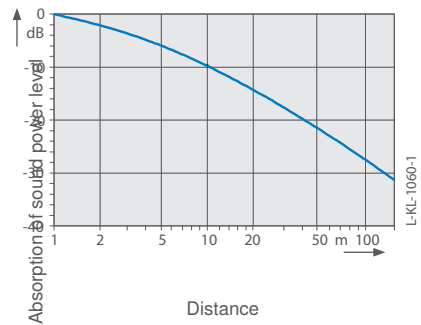

Fig. IV: Reduction of sound pressure level

Installation and usage information

Conditions for use and lifetime

Protective device

The fans may only be operated if installed appropriately for their purpose and when safety is ensured through protective devices as per DIN EN 13857 or ISO 13852 (DIN EN ISO 12100) or by other construction protection measures.

Lifetime

Thanks to the use of ball bearings with "lifetime lubrication", the axial fan is maintenance-free. The grease lasts for minimum 45000 hours in standard applications



ZIEHL-ABEGG Germany

Field service representatives

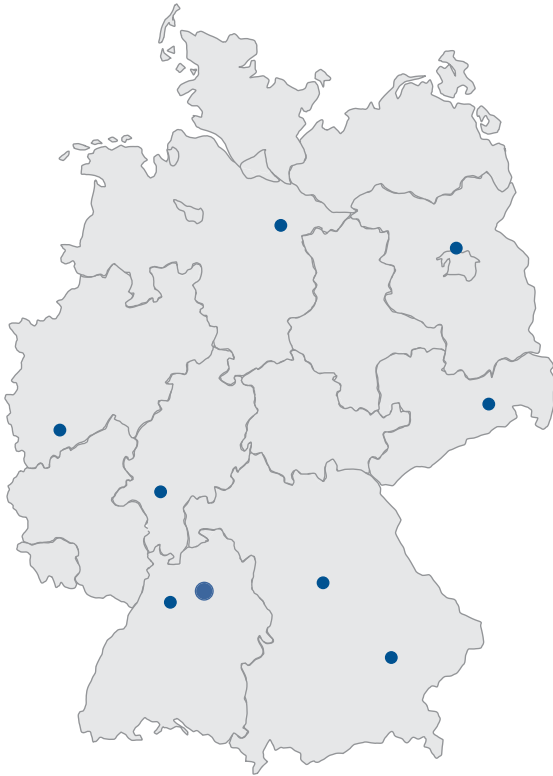

Headquarters

ZIEHL-ABEGG SE
Heinz-Ziehl-Straße
74653 Künzelsau
Tel. 07940 16-0
Fax 07940 16-300
info@ziehl-abegg.de
www.ziehl-abegg.com

Bavaria north

Michael Böhme
91126 Rednitzhembach
Phone 09122 8850964
Mobile 0160 90643765
Fax 09122 8850965
michael.boehme@
ziehl-abegg.de

Baden-Württemberg

Tomas Pilic
74257 Untereisesheim
Phone 07132 3417922
Mobile 0171 7610136
Fax 07132 3417933
tomas.pilic@ziehl-abegg.de

Hessen, Rhineland Palatinate, Saarland

Harald Keim
64859 Eppertshausen
Phone 06071 3923385
Mobile 0171 7655880
Fax 06071 3923386
harald.keim@ziehl-abegg.de

North Rhine-Westphalia, Lower Saxony West

Hans-Peter Rommerscheidt
53111 Bonn
Phone 0228 9628754
Mobile 0170 7946555
Fax 0228 9628756
hans-peter.rommerscheidt@
ziehl-abegg.de

Bavaria South

Willibald Walter
83533 Edling
Mobile 0175 2911908
willibald.walter@ziehl-abegg.de

Lower Saxony, north, east and south, Bremen, Hamburg, Schleswig-Holstein

Kai Städing
29559 Wrestedt/Nettelkamp
Phone 05802 9912
Mobile 0171 3044458
Fax 05802 9913
kai.staeding@ziehl-abegg.de

Mecklenburg-West Pomerania, Berlin, Brandenburg middle and north, Saxony-Anhalt middle and north

Wolfgang Kull
16348 Wandlitz
Phone 033056 82838
Mobile 0171 2295159
Fax 033056 82839
wolfgang.kull@ziehl-abegg.de

Saxons, Thuringia, Brandenburg south, Saxony-Anhalt south

Harald Höntsch
01219 Dresden
Phone 0351 8494892
Mobile 0170 9249851
Fax 0351 8584781
harald.hoentsch@
ziehl-abegg.de

ZIEHL-ABEGG global

Subsidiaries, sales partners

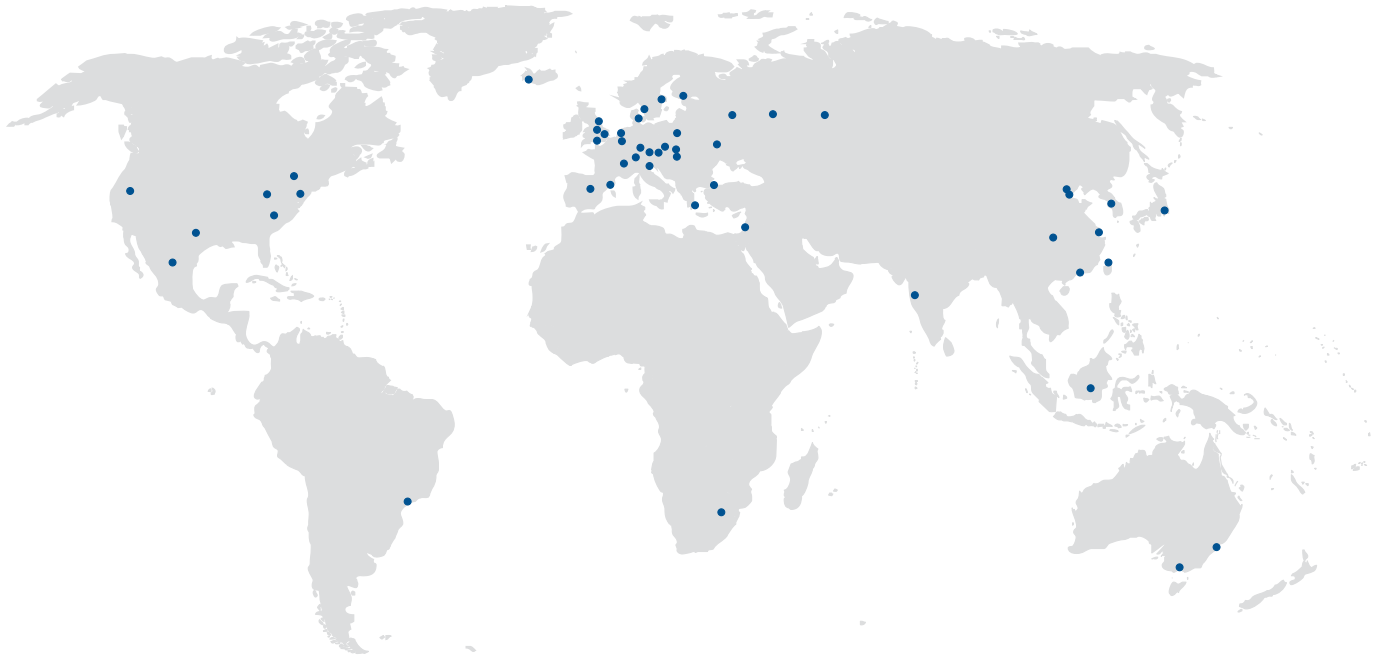

Albania

supported by
ZIEHL-ABEGG Ges.m.b.H.
AUSTRIA

Argentina

supported by
ZIEHL-ABEGG do Brasil Imp.,
Exp. e Com. de Equipamentos
de Ventilação Ltda.
BRASIL

Armenia

supported by
OOO ZIEHL-ABEGG
RUSSIA

Australia

ZIEHL-ABEGG Australia Pty Ltd
(VIC)
181 Calarco Drive
Derrimut
VICTORIA 3030
AUSTRALIA
Phone +61 3 99310899
Fax +61 3 99310499
www.ziehl-abegg.com.au
info@ziehl-abegg.com.au

Austria

ZIEHL-ABEGG Ges.m.b.H.
Prinz Eugen Strasse 19
4020 LINZ
AUSTRIA
Phone +43 732 7850950
Fax +43 732 785702
www.ziehl-abegg.at
info@ziehl-abegg.at

Azerbaijan

supported by
ZIEHL-ABEGG Ventilator ve
Motor
San ve Tic. Ltd. Sti.
TURKEY

Belarus

supported by
OOO ZIEHL-ABEGG
RUSSIA

Belgium

supported by
ZIEHL-ABEGG Benelux B.V.
NETHERLANDS

Bolivia

supported by
ZIEHL-ABEGG do Brasil Imp.,
Exp. e Com. de Equipamentos
de Ventilação Ltda.
BRASIL

Bosnia-Herzegovina

supported by
ZIEHL-ABEGG Ges.m.b.H.
AUSTRIA

Brazil

ZIEHL-ABEGG do Brasil Imp.,
Exp. e Com. de Equipamentos
de Ventilação Ltda.
Rua Osasco, 1.295
Centro Empresarial Anhanguera
Cajamar -SP - CEP 07753-040
BRAZIL
Phone + 55 11 2898-0827
www.ziehl-abegg.com.br
info@ziehl-abegg.com.br

Bulgaria

supported by
ZIEHL-ABEGG Ges.m.b.H.
AUSTRIA

Canada

supported by
ZIEHL-ABEGG Inc.
USA

Chile

supported by
ZIEHL-ABEGG do Brasil Imp.,
Exp. e Com. de Equipamentos
de Ventilação Ltda.
BRASIL

China

ZIEHL-ABEGG Mechanical
and Electrical Equipment
(Shanghai)
Co. Ltd.
No. 65 Hong Mu Dan Road
Xinbang Town
Songjiang District
SHANGHAI 201605
CHINA
Phone +86 21 57893991
Fax +86 21 57893932
www.ziehl-abegg.cn
info@ziehl-abegg.com.cn

Colombia

ZIEHL-ABEGG fans and drives
Carrera 7B No. 126 – 49
Oficina 104 Bogotá
COLOMBIA

Croatia

supported by
ZIEHL-ABEGG Ges.m.b.H.
AUSTRIA

Czech Republic

ZIEHL-ABEGG s.r.o.
Škrobárenská 484/8
617 00 BRNO
Czech REPUBLIC
Phone +420 5 45421690
Fax +420 5 45421699
www.ziehl-abegg.cz
sales@ziehl-abegg.cz

Denmark

ZIEHL-ABEGG Danmark ApS
Pakhusgården 40
5000 Odense C
DENMARK
Phone +45 66 155800
Fax +45 66 155810
www.ziehl-abegg.com
carsten.sundman@ziehl-abegg.com

Ecuador

supported by
ZIEHL-ABEGG do Brasil Imp.,
Exp. e Com. de Equipamentos
de Ventilação Ltda.
BRASIL

Estonia

supported by
ZIEHL-ABEGG Finland OY
FINLAND

Finland

ZIEHL-ABEGG Finland OY
Olarinluoma 11
02200 ESPOO
FINLAND
Phone +358 10 40068-00
Fax +358 10 40068-10
www.ziehl-abegg.fi
info@ziehl-abegg.fi



France

ZIEHL-ABEGG France Sarl
Rue de la gare
01800 VILLIEU
FRANCE
Phone +33 474 4606-20
Fax +33 474 611958
www.ziehl-abegg.fr
societe@ziehl-abegg.fr

Georgia

supported by
ZIEHL-ABEGG Ventilator ve
Motor
San ve Tic. Ltd. Sti.
TURKEY

Great Britain

ZIEHL-ABEGG UK Ltd.
Springfield Business Park
Lonebarn Link, Unit 1
CHELMSFORD, ESSEX CM2
5AR
GREAT BRITAIN
Phone +44 1245 4490-10
Fax +44 1245 4490-11
www.ziehl-abegg.co.uk
info@ziehl-abegg.co.uk

Greece

supported by
ZIEHL-ABEGG SE
GERMANY

Hungary

supported by
ZIEHL-ABEGG Ges.m.b.H.
AUSTRIA
Phone +36 30 821 5226

Iceland

Varmi HF
Laugavegi 168
0105 REYKJAVIK
ICELAND
Phone +354 5517560
Fax +354 5624110
www.varmi.is
varmi@varmi.is

India

ZIEHL-ABEGG India Pvt Ltd.
GAT No.679/2/3,
Kuruli Village
Tal Khed Dist.
PUNE - 410501
INDIA
Phone +91 21 3567 9679
Fax +91 21 3567 9680
www.ziehl-abegg.in
vikas.kundra@ziehl-abegg.com

Indonesia

ZIEHL-ABEGG SEA Pte. Ltd.
Indonesia Representative Office
Heartline Center Building,
2nd Floor, No.201,
Jl. Permatasari 1000, Villa
Permata
Lippo Karawaci, Tangerang
15810
INDONESIEN
Phone +62 21 5988181
Fax +62 21 5988181
www.ziehl-abegg.sg
rudysusanto@ziehl-abegg.com.sg

Iraq

supported by
ZIEHL-ABEGG Ventilator ve
Motor
San ve Tic. Ltd. Sti.
TURKEY

Ireland

supported by
ZIEHL-ABEGG UK Ltd.
GREAT BRITAIN

Italy

ZIEHL-ABEGG Italia S.r.l.
Via Primo Maggio 10
30031 DOLO (VE)
ITALY
Phone +39 041 5130-311
Fax +39 041 5131-953
www.ziehl-abegg.it
info@ziehl-abegg.it

Japan

ZIEHL-ABEGG Japan Co., Ltd.
9F Yokohama Hanasaki Build-
ing,
6-145 Hanasaki-cho, Nishi-ku
YOKOHAMA, KANAGAWA 220-
0022
JAPAN
Phone +81 45 3281295
Fax +81 45 3230108
www.ziehl-abegg.com
info@ziehl-abegg.jp

Jordan

supported by
ZIEHL-ABEGG Ventilator ve
Motor
San ve Tic. Ltd. Sti.
TURKEY

Kazakhstan

supported by
OOO ZIEHL-ABEGG
RUSSIA

Korea

Jung Air Technics Co., Ltd.
#831, Hyundai Etrebeau Bldg.
852, Janghang-Dong, Ilsan-Ku
GOYANG-CITY (411-837)
KOREA
Phone +82 31 9033071
Fax +82 31 9033072
www.jungairtechnics.com
jat@nuri.net

Kyrgyzstan

supported by
OOO ZIEHL-ABEGG
RUSSIA

Latvia

supported by
ZIEHL-ABEGG Polska Sp. z o.o.
POLAND

Lithuania

supported by
ZIEHL-ABEGG Polska Sp. z o.o.
POLAND

Macedonia

supported by
ZIEHL-ABEGG Ges.m.b.H.
AUSTRIA

Malaysia

supported by
ZIEHL-ABEGG SEA Pte. Ltd.
SINGAPORE

Mexico

supported by
ZIEHL-ABEGG Inc.
USA

Moldova

supported by
OOO ZIEHL-ABEGG
RUSSIA

Mongolia

supported by
ZIEHL-ABEGG Mechanical and
Electrical Equipment (Shanghai)
Co. Ltd.
CHINA

Montenegro

supported by
ZIEHL-ABEGG Ges.m.b.H.
AUSTRIA

Netherlands

ZIEHL-ABEGG Benelux B.V.
Veldweg 20c
Postbus 36
5320 AA HEDEL
NETHERLANDS
Phone +31 73 594 7000
Fax +31 73 594 7009
www.ziehl-abegg.nl
info@ziehl-abegg.nl

New Zealand

supported by
ZIEHL-ABEGG Australia Pty Ltd
(VIC)
AUSTRALIA

Norway

supported by
ZIEHL-ABEGG Sverige AB
SWEDEN

Paraguay

supported by
ZIEHL-ABEGG do Brasil Imp.,
Exp. e Com. de Equipamentos
de Ventilação Ltda.
BRASIL

Peru

supported by
ZIEHL-ABEGG do Brasil Imp.,
Exp. e Com. de Equipamentos
de Ventilação Ltda.
BRASIL

Philippines

supported by
ZIEHL-ABEGG SEA Pte. Ltd.
SINGAPORE

Poland

ZIEHL-ABEGG Polska Sp. z o.o.
ul. Sochaczewska 13
01-327 WARSZAWA
POLAND
Phone +48 22 6654933
Fax +48 22 6640134
www.ziehl-abegg.pl
biuro@ziehl-abegg.pl

Portugal

supported by
ZIEHL-ABEGG Ibérica S.L.
SPAIN

Romania

supported by
ZIEHL-ABEGG Ges.m.b.H.
AUSTRIA

Russia

OOO ZIEHL-ABEGG
34/building 3
Khotovskaya Str.
Schelkovo
141101 MOSCOW REGION
RUSSIA
Phone +7 495 2215665
Fax +7 495 2215665
www.ziehl-abegg.ru
info@ziehl-abegg.ru

Serbia

supported by
ZIEHL-ABEGG Ges.m.b.H.
AUSTRIA

Singapore

ZIEHL-ABEGG SEA Pte. Ltd.
57 Ubi Avenue 1
#05-04 Ubi Centre
SINGAPORE 408936
SINGAPORE
Phone +65 67482587
Fax +65 67487357
www.ziehl-abegg.sg
info@ziehl-abegg.com.sg

Slovakia

supported by
ZIEHL-ABEGG s.r.o.
CZECH REPUBLIC

Slovenia

supported by
ZIEHL-ABEGG Ges.m.b.H.
AUSTRIA

South Africa

ZIEHL-ABEGG South Africa
(Pty) Ltd.
51 Loper Road
Spartan / Aeroport
Kempton Park
JOHANNESBURG
SOUTH AFRICA
Phone +27 11 9744211
Fax +27 11 9747970
www.ziehl-abegg.co.za
info@ziehl-abegg.co.za

Spain

ZIEHL-ABEGG Ibérica S.L.
C/ Calidad 58
Polígono Industrial Los Olivos
28906 GETAFE (MADRID)
SPAIN
Phone +34 91 2953008
Fax +34 91 2953014
www.ziehl-abegg.es
info@ziehl-abegg.es

ZIEHL-ABEGG global

Subsidiaries, sales partners

Sweden

ZIEHL-ABEGG Sverige AB
Kvartsgatan 11
749 40 ENKÖPING
SWEDEN
Phone +46 171 8588-0
Fax +46 171 8588-1
www.z-abegg.se
info@z-abegg.se

Switzerland

ZIEHL-ABEGG Schweiz AG
Limmatstrasse 12
8957 SPREITENBACH
SWITZERLAND
Phone +41 56 41850-10
Fax +41 56 41850-15
www.ziehl-abegg.ch
info@ziehl-abegg.ch

Syria

supported by
ZIEHL-ABEGG Ventilator ve
Motor
San ve Tic. Ltd. Sti.
TURKEY

Taiwan

Tuntos Enterprise Co. Ltd.
No. 23-1, Alley 10, Lane 437,
Pa-Der Road, Sec 2,
TAIPEI, TAIWAN R.O.C.
TAIWAN
Phone +886 2 27512135
Fax +886 2 27775343
www.tuntos.com.tw
tuntos@ms23.hinet.net

Tajikistan

supported by
OOO ZIEHL-ABEGG
RUSSIA

Thailand

supported by
ZIEHL-ABEGG SEA Pte. Ltd.
SINGAPORE

Turkey

ZIEHL-ABEGG Ventilator ve
Motor
San ve Tic. Ltd. Sti.
Atatürk Mah. Firat Bulvari
Gardenya Plaza 3. Binasi
Kat:3 Ofis No: 17
34758 ATAŞEHİR-İSTANBUL
TURKEY
Phone +90 216 5808250
Fax +90 216 5809530
www.ziehl-abegg.com.tr
omur.aydogan@ziehl-abegg.
com.tr

Turkmenistan

supported by
ZIEHL-ABEGG Ventilator ve
Motor
San ve Tic. Ltd. Sti.
TURKEY

Ukraine

ZIEHL-ABEGG Ukraine Ltd
46 Budenogo str.
08700 OBUHOV, KIEV REGION
UKRAINE
Phone +38 067 4637958
Fax +38 044 4927409
ua.ziehl-abegg.com
info@ziehl-abegg.com.ua

USA

ZIEHL-ABEGG Inc.
719 N. Regional Road
GREENSBORO, NC 27419
USA
Phone +1 336 8349339
Fax +1 336 8349340
www.ziehl-abegg.us
info@ziehl-abegg.us

Uruguay

supported by
ZIEHL-ABEGG do Brasil Imp.,
Exp. e Com. de Equipamentos
de Ventilação Ltda.
BRASIL

Uzbekistan

supported by
OOO ZIEHL-ABEGG
RUSSIA

Venezuela

supported by
ZIEHL-ABEGG do Brasil Imp.,
Exp. e Com. de Equipamentos
de Ventilação Ltda.
BRASIL

Vietnam

supported by
ZIEHL-ABEGG SEA Pte. Ltd.
SINGAPORE



General notes

The information and data contained in this catalogue were composed to the best of our best ability and do not absolve the user from its duty to check the suitability of the products with respect to its intended application.

ZIEHL-ABEGG SE reserves the right to make design changes, which are used for continuous technical improvement.

The customer is obligated to inform the supplier about general information concerning the intended use, the type of installation, the operating conditions and any other conditions that need to be taken into consideration if the order is not based on catalogue information.

ECblue and FE2owlet are registered trademarks of ZIEHL-ABEGG SE

Copyright

ZIEHL-ABEGG SE reserves in its entirety the copyright of this catalogue. The catalogue is intended for proper use as intended and neither the catalogue, its content nor extracts may be passed on to third parties without our express written consent.

The Royal League

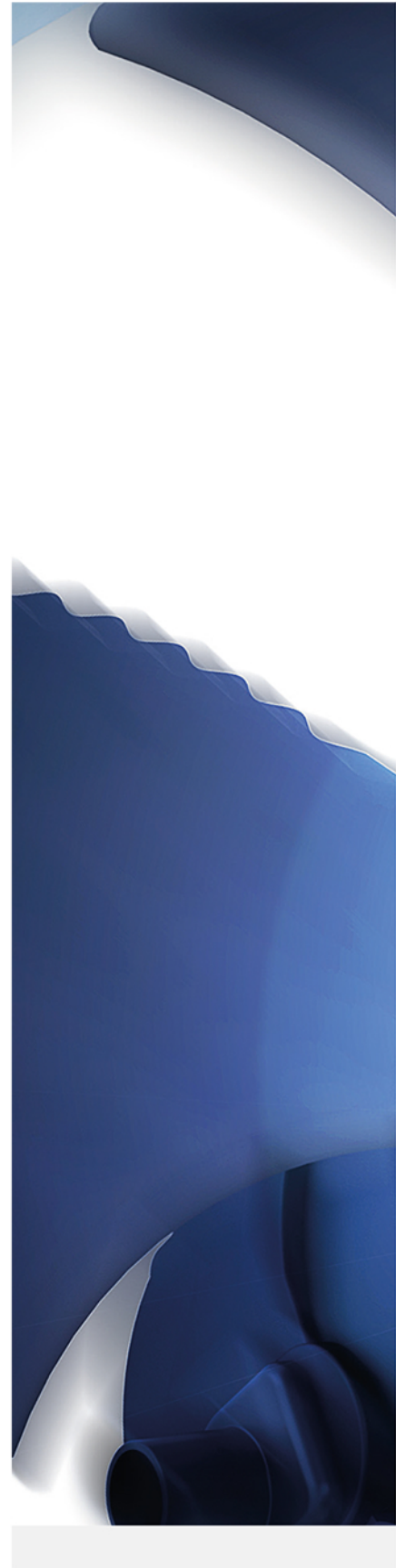

© ZIEHL-ABEGG SE - 00702749 - EN - MA - 06/2015 - xxx - OHA Druck - Subject to technical modifications