

- ALL STEEL CONSTRUCTION
- INTEGRAL STEEL MULTI-SHUTTER DAMPER
- 1/3 INCH SPACED FINS SET AT 20 DEGREES
- MINIMUM SIZE = 8 X 4 (2 SCREW HOLES)
- MAXIMUM SIZE = 16 X 6 (4 SCREW HOLES)
- 3-WAY DEFLECTION
- FOR HEATING OR COOLING
- FINISH: WHITE (W) ENAMEL

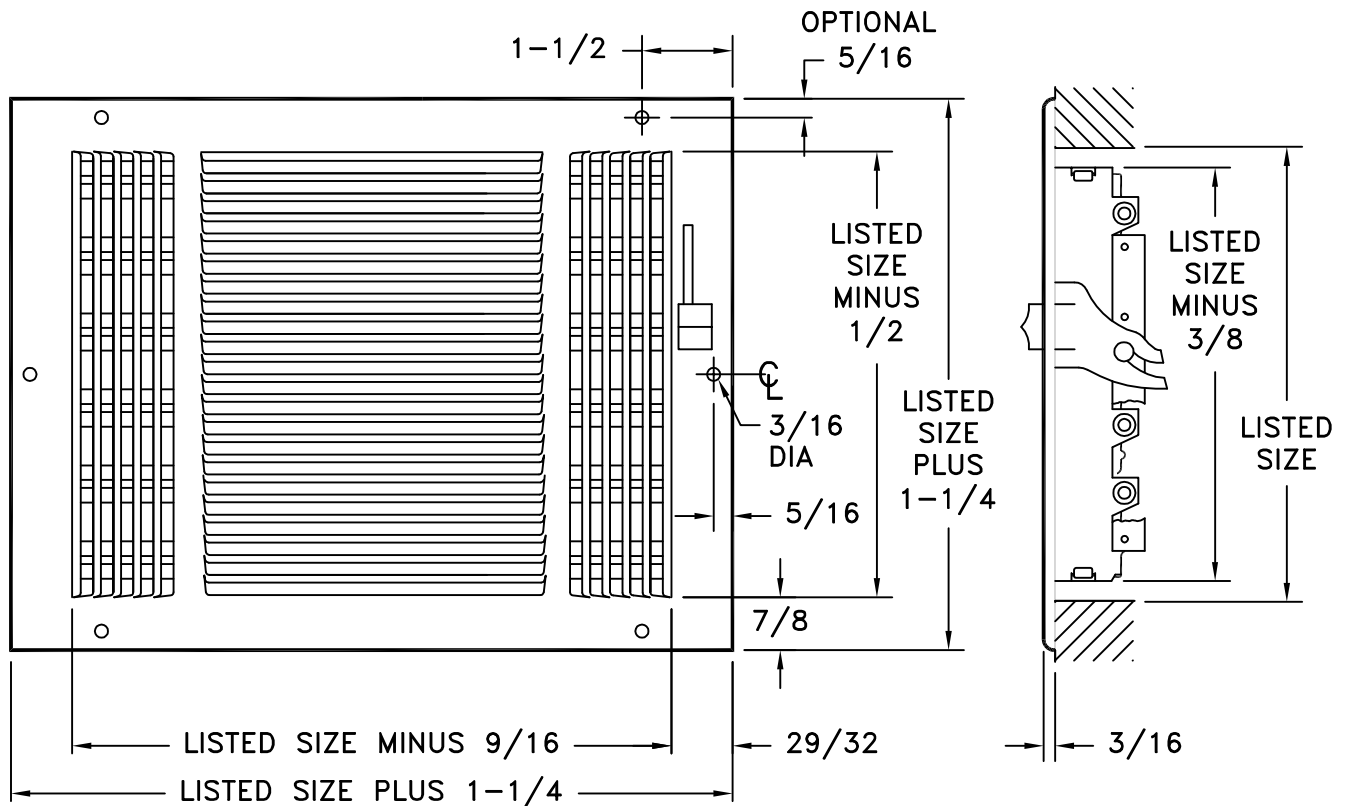

JOB NAME: _____	SUBMITTED BY: _____	DATE: 08/23/2013	SD-2416
LOCATION: _____		631 Steel 3-Way Stamped Face Register	
ARCHITECT: _____			
ENGINEER: _____			
CONTRACTOR: _____			