

Imperial [IP] Dimensions
Metric (SI) in Parentheses

CARNES COMPANY 448 S. Main St., P. O. Box 930040, Verona, WI 53593-0040 Phone: (608)845-6411 Fax: (608)845-6504 www.carnes.com

SIZES
4 - 20

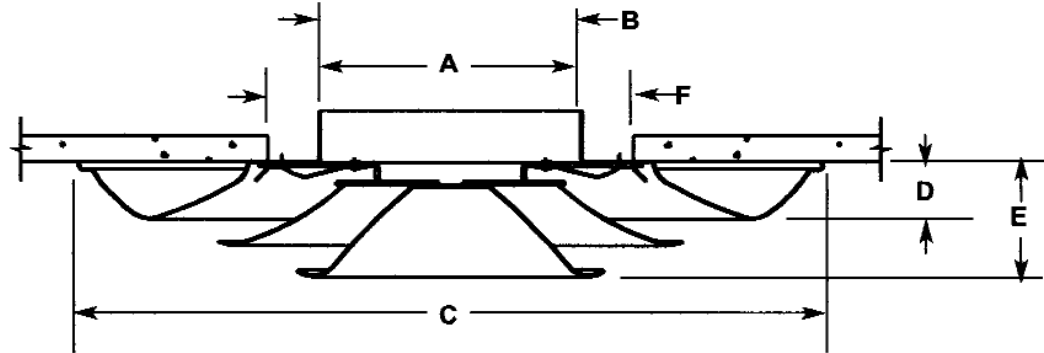

SIZES
24 - 36

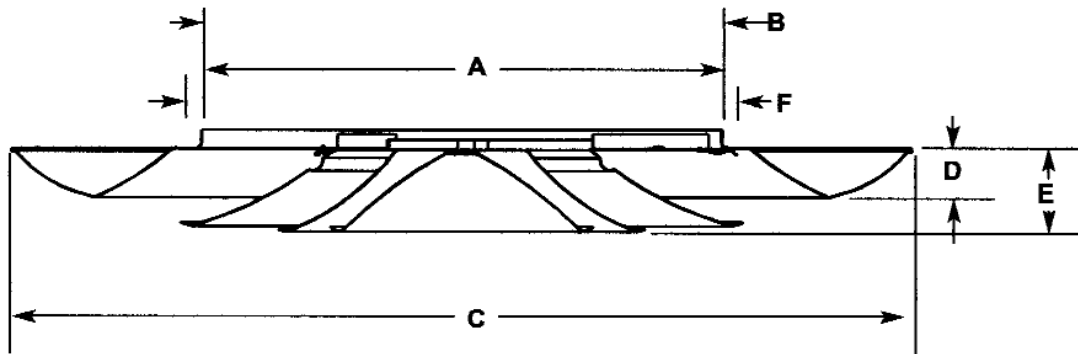

Dim. Description	4	5	6	8	10	12	14	16	18	20	24	28	32	36
A Neck Inside Diameter	4-1/16 (103)	5-1/16 (129)	6-1/16 (154)	8-1/16 (205)	10-1/16 (256)	12-1/16 (306)	14-1/16 (357)	16-1/16 (408)	18-1/16 (459)	20-1/16 (510)	24-1/16 (611)	28-1/16 (713)	32-1/16 (814)	36-1/16 (916)
B Neck Outside Diameter	4-1/8 (105)	5-1/8 (130)	6-1/8 (156)	8-1/8 (206)	10-1/8 (257)	12-1/8 (308)	14-1/8 (359)	16-1/8 (410)	18-1/8 (460)	20-1/8 (511)	24-1/8 (613)	28-1/8 (714)	32-1/8 (816)	36-1/8 (918)
C Frame Outside Diameter	14-1/2 (368)	14-1/2 (368)	14-1/2 (368)	17-9/16 (446)	19-13/16 (503)	22-1/16 (560)	24-1/16 (611)	28-13/16 (732)	32-1/16 (814)	33-9/16 (852)	39-5/16 (999)	48-9/16 (1233)	60-13/16 (1545)	60-13/16 (1545)
D Form Projection	1-3/16 (30)	1-3/16 (30)	1-3/16 (30)	1-3/8 (35)	1-3/8 (35)	1-3/8 (35)	1-1/2 (38)	2-1/8 (54)	2-1/8 (54)	2-1/4 (57)	2-5/8 (67)	2-11/16 (68)	2-7/8 (73)	2-7/8 (73)
E Overall Projection	1-15/16 (49)	1-15/16 (49)	1-15/16 (49)	2-3/8 (60)	1-7/8 (48)	2-15/16 (59)	2-15/16 (59)	2-3/4 (70)	3-1/8 (79)	3-1/8 (79)	3-11/16 (94)	4-1/2 (114)	4-15/16 (125)	4-15/16 (125)
F Rec. Ceiling Opening	7-1/4 (184)	7-1/4 (184)	7-1/4 (184)	9-1/4 (235)	11-1/4 (286)	13-1/4 (337)	15-1/4 (387)	17-1/4 (438)	19-1/4 (489)	21-1/4 (540)	25-1/4 (641)	29-1/4 (743)	33-1/4 (845)	37-1/4 (946)
G Collar Height	3/4 (19)	1-3/8 (35)	1 (25)	1 (25)	1 (25)	1 (25)	1 (25)	1 (25)	1 (25)	1 (25)	1 (25)	1 (25)	1 (25)	1 (25)

Notes:

1. Aluminum construction.
2. Standard finish is electrocoat acrylic baked enamel. Other finishes are available on request.
3. Standard color is #11 Bright White. Other colors are available on request.
4. Neck is oversized to fit over standard duct.