

IP [English] Dimensions
SI (Metric) In Parentheses

CARNES COMPANY 448 S. Main St., P. O. Box 930040, Verona, WI 53593-0040 Phone: (608)845-6411 Fax: (608)845-6504 www.carnes.com

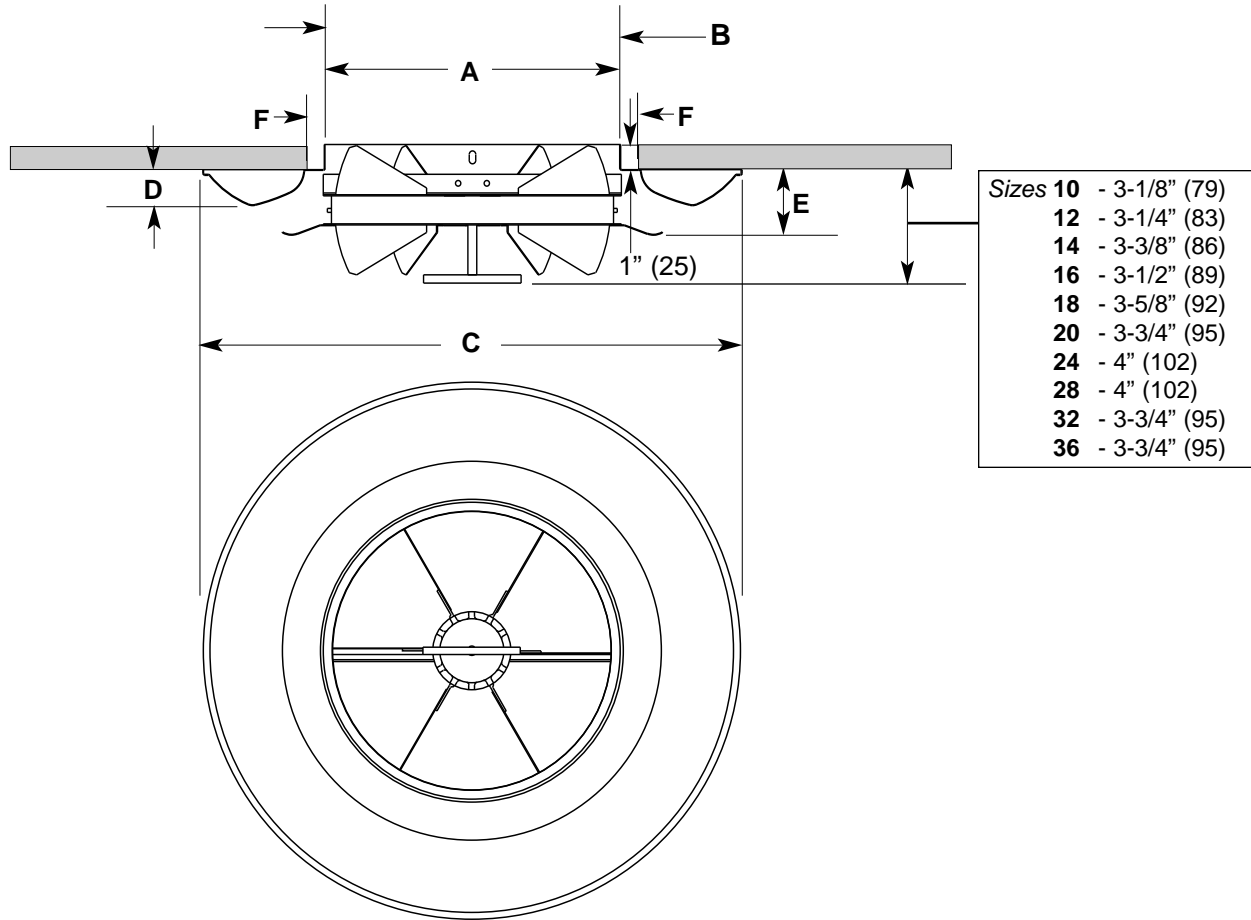

DIMENSIONS LISTED IN INCHES (Millimeters)

Dim.	Description	Nominal Neck Size						
		10	12	14	16	18	20	24
A	Neck ID	10-1/16 (256)	12-1/16 (306)	14-1/16 (357)	16-1/16 (408)	18-1/16 (459)	20-1/16 (510)	24-1/16 (611)
B	Neck OD	10-1/8 (257)	12-1/8 (308)	14-1/8 (359)	16-1/8 (410)	18-1/8 (460)	20-1/8 (511)	24-1/8 (613)
C	Face OD	19-13/16 (503)	22-1/16 (560)	24-1/16 (611)	28-13/16 (732)	32-1/16 (814)	33-9/16 (852)	39-5/16 (998)
D	Form Projection	1-3/16 (30)	1-3/8 (35)	1-1/2 (38)	2-1/8 (54)	2-1/8 (54)	2-1/4 (57)	2-5/8 (67)
E	Overall Projection	1-15/16 (49)	2-3/16 (56)	2-5/16 (59)	3 (76)	3-9/16 (90)	3-7/16 (87)	3-15/16 (100)
F	Rec. Ceiling Opening	11-1/4 (286)	13-1/4 (337)	15-1/4 (387)	17-1/4 (438)	19-1/4 (489)	21-1/4 (540)	25-1/4 (641)

Dim.	Description	Nominal Neck Size		
		28	32	36
A	Neck ID	28-1/16 (713)	32-1/16 (814)	36-1/16 (922)
B	Neck OD	28-1/8 (714)	32-1/8 (816)	36-1/8 (918)
C	Face OD	48-9/16 (1233)	60-13/16 (1545)	60-13/16 (1545)
D	Form Projection	2-11/16 (68)	2-7/8 (73)	2-7/8 (73)
E	Overall Projection	5-3/16 (132)	6-9/16 (167)	6-9/16 (167)
F	Rec. Ceiling Opening	29-1/4 (818)	33-1/4 (845)	37-1/4 (946)

Notes:

1. Construction is heavy gauge steel.
2. The standard finish is electrocoat acrylic baked enamel. Other finishes are available upon request.
3. Standard color is #11 Bright White. Other colors are available on request.
4. Discharge is adjustable from horizontal to vertical by twisting the control handle 45°.
5. Neck is oversized to fit over the duct.
6. Metric dimensions are given in millimeters.
7. Core is removed by disengaging locking springs, then twisting core.