

Imperial [IP] Dimensions
Metric (SI) in Parentheses

Square and Rectangular Diffusers Alum. Const. — Adjustable — For Tetular Type Ceilings

CARNES COMPANY 448 S. Main St., P. O. Box 930040, Verona, WI 53593-0040 Phone: (608)845-6411 Fax: (608)845-6504 www.carnes.com

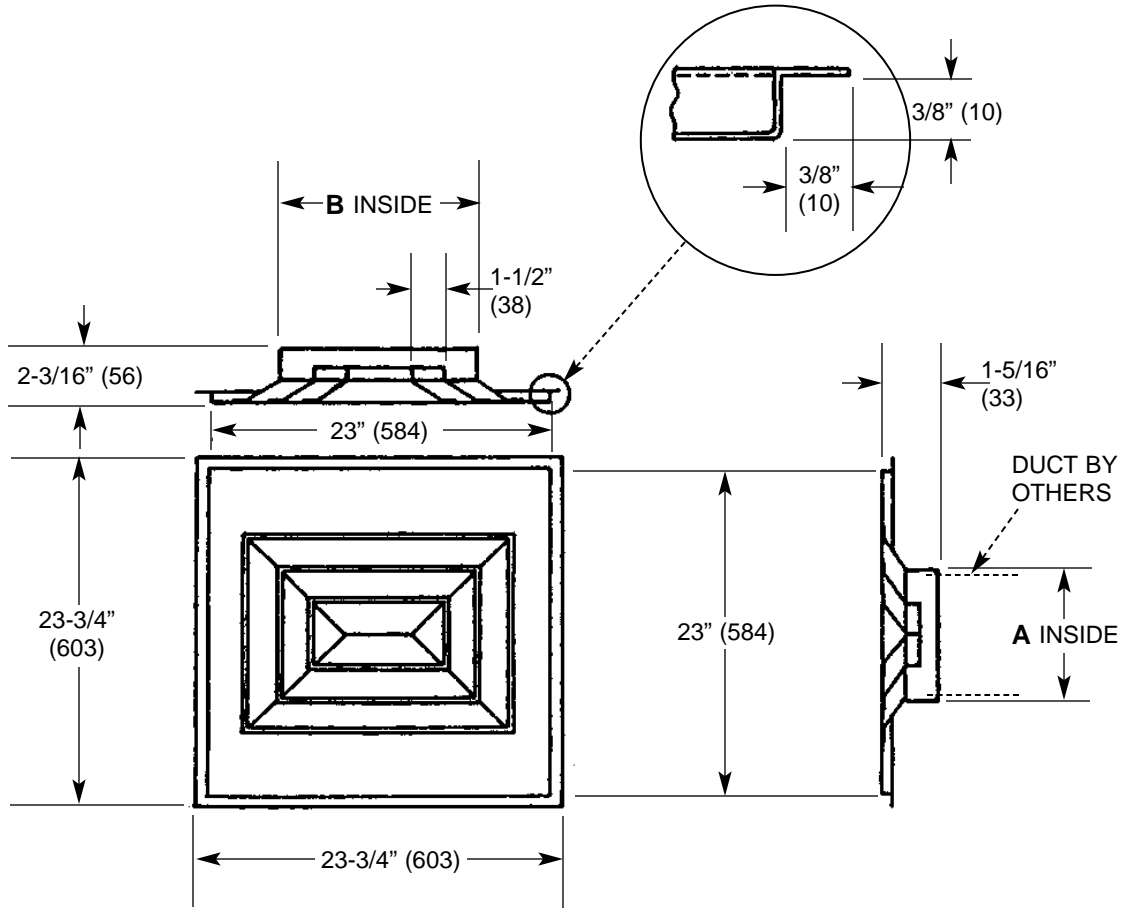

SQUARE

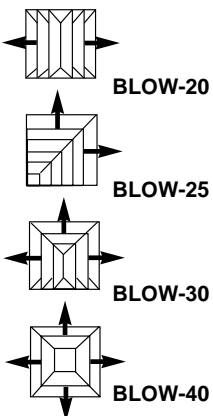

RECTANGULAR

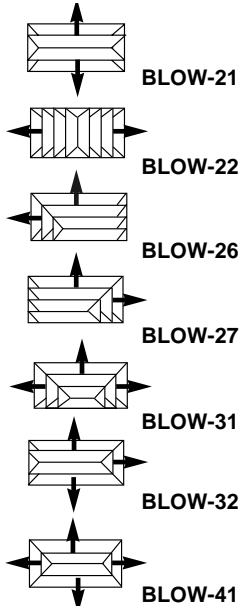

ADJUSTMENT

HORIZONTAL
AIR FLOW

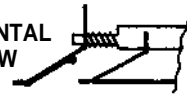

VERTICAL
AIR FLOW

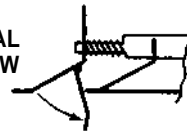

Two spring loaded pins, four pin suspension to ceiling plate. Removable and interchangeable center core assembly.

Note:

- Standard Finish #11 White Electrocoat

DIMENSIONS LISTED IN INCHES (Millimeters)

Size A x B	Size A x B	Size A x B
6 x 6 (152 x 152)	9 x 9 (229 x 229)	12 x 15 (305 x 381)
6 x 9 (152 x 229)	9 x 12 (229 x 305)	12 x 18 (305 x 457)
6 x 12 (152 x 305)	9 x 15 (229 x 381)	15 x 15 (381 x 381)
6 x 15 (152 x 381)	9 x 18 (229 x 457)	15 x 18 (381 x 457)
6 x 18 (152 x 457)	12 x 12 (305 x 305)	18 x 18 (457 x 457)