

HVAC HEATING PRODUCTS

Application Manual

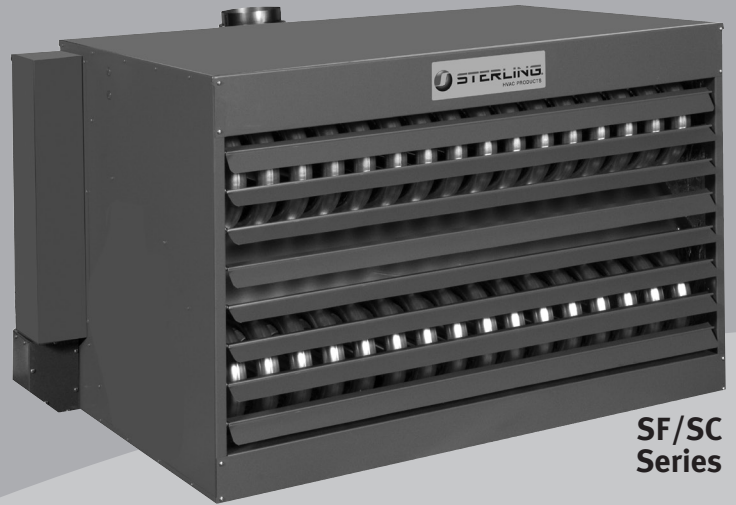

TF/TC
Series



SF/SC
Series



GG
Series

GAS-FIRED HEATING EQUIPMENT

- Tubular Unit Heaters
- Duct Furnaces
- Cabinet Blowers



Contents

	PAGE
GENERAL INFORMATION – Tubular	3
APPLICATIONS	4
GG SERIES	
Standard/Optional Features	5
Unit Number Description	5
Performance Data and Dimensional Data	6
Dimensional Data	7
TF/TC SERIES	
Standard/Optional Features	8
Unit Number Description	8
Performance and Dimensional Data – TF Series	9
Performance and Dimensional Data – TC Series	10
Performance Data – TC Series	11
SF/SC SERIES	
Standard/Optional Features	12
Unit Number Description	12
Performance and Dimensional Data – SF Series	13
Performance and Dimensional Data – SC Series	14
Performance Data – SC Series	15
TD SERIES	
General Information – Duct Furnace	16
Standard/Optional Features	17
Unit Number Description	17
Dimensional Data – TD Series	18
Performance Data – TD Series	19
QVED/QVES/QVSD SERIES	
Standard Features	20-21
Unit Number Description	21
Performance and Dimensional Data – QVSD Series	22
Performance and Dimensional Data – QVED Series	23
Performance and Dimensional Data – QVES Series	23
Dimensional Data – QVED/QVES Series	24
CAB SERIES	
Standard Features	25
Unit Number Description	25
Motor Data	25
Dimensional Data – CAB Series	26
Performance Data – CAB Series	27
OPTIONAL ACCESSORIES – All Series	28-29
HEAT THROW DATA – All Series	30-31
NOZZLE DIMENSIONS	32
TYPICAL STANDARD SPECIFICATIONS	
GG Series	33
TF/TC Series	33
SF/SC Series	33
TD Series	34
QVED/QVES/QVSD Series	34
CAB Series	34
WARRANTY – All Series	35

Tubular Unit Heaters



GG Series



TF Series

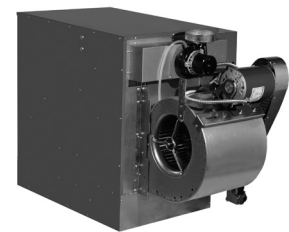

TC Series



SF Series

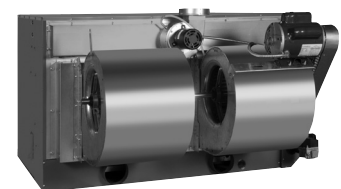

SC Series

- **GG SERIES**
- **TF SERIES**
- **TC SERIES**
- **SF SERIES**
- **SC SERIES**
- **TD SERIES**

General Information

STERLING TUBULAR DESIGN GAS FIRED UNIT HEATER

The Sterling Tubular gas-fired unit heaters offer a highly efficient, extremely durable alternative to the traditional clam shell design. These units combine the latest tubular heat exchanger and inshot burner technology with the quality and reliability you have come to know from Sterling.

HIGH EFFICIENCY

Standard energy saving features like the direct spark ignition and power venting reduce standby losses and offer improved seasonal efficiencies. Tubular units certified by ETL as providing 83% thermal (combustion) efficiency.

TUBULAR HEAT EXCHANGER

The Sterling tubular heat exchanger has been designed to provide maximum and uniform heat transfer. The low pressure drop associated with this design enables heated air to be evenly distributed to the conditioned space. This curved, non-welded serpentine design experiences less thermally induced stress making it highly durable for significantly longer service life. All Sterling tubular heat exchangers are constructed of heavy duty 20-gauge aluminized steel. Optional 409 stainless steel heat exchangers are also available.

DIRECT SPARK IGNITION SYSTEM

Sterling Tubular units utilize a direct spark pilotless ignition of the burner, providing fast heat delivery. This highly reliable and efficient ignition system incorporates an integrated electronic control board to regulate the system sequence of operation, including an onboard LED indicator for simple troubleshooting.

VENTING

The Sterling Tubular unit heaters are ETL certified in accordance with categories I and III venting requirements. This certification allows units to be vented both vertically and horizontally using either single wall or double wall venting materials. This venting flexibility of the unit heater makes installation easier and more cost effective by allowing the installer to utilize existing venting components.

CONTROL ACCESSIBILITY

Designed with the service person in mind, every component of the Sterling unit heaters is easily accessible. Ignition and fan controls are located in one centrally located control panel. The access door provides control isolation as well as a pleasing exterior appearance.

10-YEAR WARRANTY

Sterling warranties the heat exchanger, flue collector and burners of each unit heater to be free from defects in materials and workmanship for a period of 10 years from the date of manufacture.

SEPARATED COMBUSTION - SF/SC SERIES

The SF/SC series heater “separates” the combustion process from the environment where the unit is installed. A power venting system draws a controlled quantity of combustion air from outside the building. The same system exhausts flue products to the outside. The burners and flue system are enclosed within the unit; thus, the entire combustion process is unaffected by the atmosphere in the space where the heater is located. Separated combustion units are designed to be installed where dusty, dirty or mildly corrosive conditions exist or where high humidity or slightly negative pressure prevail.

Applications

UNIT HEATER PLACEMENT

Gas-fired unit heaters are used primarily in commercial and industrial buildings such as warehouses, manufacturing areas, garages, showrooms, lobbies, etc. Placement is typically determined by air distribution requirements. Proper distributions should have air directed toward areas of greatest heat loss. Multiple units may be used to greatest effect by positioning units around the perimeter. Several units near the center and with air discharging toward outside walls may also satisfy the heating requirements. Direct air discharge on occupants should be avoided.

TYPICAL APPLICATIONS

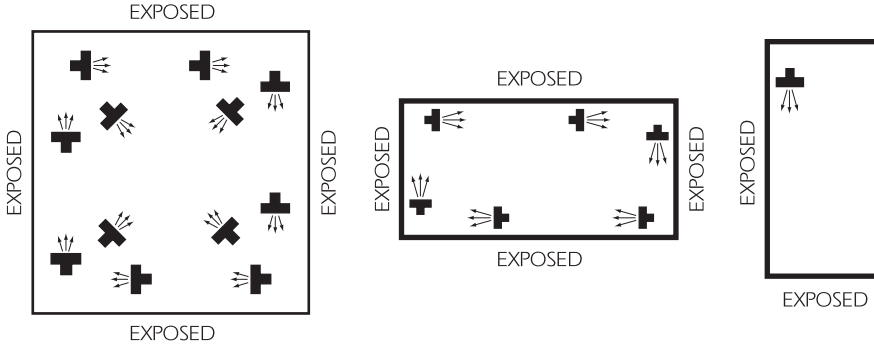

A large square area with exposed walls and roof; units are blanketing all exposed surfaces.

A narrow area with four exposed walls either with or without roof exposure.

A small area with exposed walls requiring one unit.

HOW TO CALCULATE HEAT LOSS

It is suggested that when calculating heat loss for a building, reference be made to procedures outlined in the **ASHRAE Handbook**. As an easy reference, however, the following abbreviated method may be used with a good degree of reliability.

1. Determine inside temperature to be maintained and the design outside temperature for your locality. The difference between these two figures is the design temperature difference.
2. Calculate net areas in square feet of glass, wall, floor, and roof exposed to outside temperature or unheated spaces. Calculate door as all glass.
3. Select heat-transfer coefficients from the table below (or the **ASHRAE Handbook**) and compute the heat-transmission loss for each area in BTU/HR by multiplying each area by the heat-transfer coefficient and the temperature difference.
4. Add 10% to the heat-loss figures for areas exposed to prevailing winds.
5. Calculate the volume of the room or area in cubic feet and multiply by the estimated number of air changes per hour due to infiltration (usually from one to two). Determine the number of cubic feet per hour of air exhausted by ventilating fans or industrial processes. Substitute the larger of these two figures in the formula to determine the heat required to raise the air from outside to room temperature —

$$\text{BTU/HR} = \frac{\text{cubic feet per hour} \times \text{temperature difference}}{55}$$

6. The totals of BTU/HR losses from 3, 4 and 5 (above) will give the total BTU/HR to be supplied by unit heaters. (Note: If processes performed in the room liberate considerable amounts of heat, this may be determined as accurately as possible and subtracted from the total).

Building Material	"U" Factor
WALLS	
Poured concrete 80#/cu. feet	
8-inch	0.25
12-inch	0.18
Concrete Block, hollow cinder aggregate	
8-inch	0.39
12-inch	0.36
Gravel aggregate	
8-inch	0.52
12-inch	0.47
Concrete Block, w/4-inch facebrick	
Gravel, 8-inch	0.41
Cinder, 8-inch	0.33
Metal	
(un-insulated)	1.17
w/1-inch blanket insulation	0.22
w/3-inch blanket insulation	0.08
ROOFING	
Corrugated Metal (un-insulated) ...	1.50
w/1-inch bolt or blanket	0.23
w/1-1/2-inch bolt or blanket ..	0.16
w/3-inch bolt or blanket	0.08
Flat Metal	
w/3/8-inch built-up roofing	0.90
w/1-inch blanket insulation under deck	0.21
w/2-inch blanket insulation under deck	0.12
Wood/ 1" /(un-insulated)	
w/3/8-inch built-up roofing	0.48
w/1-inch blanket insulation	0.17
Wood/ 2" /(un-insulated)	
w/3/8-inch built-up roofing	0.32
w/1-inch blanket insulation	0.15
Concrete slab/ 2" /(un-insulated)	
w/3/8-inch built-up roofing	0.30
w/1-inch insulation board	0.16
Concrete slab/ 3" /(un-insulated)	
w/3/8-inch built-up roofing	0.23
w/1-inch insulation board	0.14
Gypsum slab/ 2" /(un-insulated)	
w/1/2-inch gypsum board	0.36
w/1-inch insulation board	0.20
Gypsum slab/ 3" /(un-insulated)	
w/1/2-inch gypsum board	0.30
w/1-inch insulation board	0.18
WINDOWS	
Vertical, single-glass	1.13
Vertical, double-glass, 3/16-inch air space	0.69
Horizontal, single-glass (sky light)	1.40
DOORS	
Metal — single sheet	1.20
Wood, 1-inch	0.64
2-inch	0.43

GG Series — Low Profile Unit Heater

RESIDENTIAL AND COMMERCIAL CERTIFICATIONS

The Sterling GG Series unit heater conforms with the latest ETL certification standards. Design certified under ANSI Z83.8 for Industrial/Commercial use and the more demanding requirements of CSA 10.96 USA (2nd ed.) "Unit Heaters for Residential Installation", make this low profile unit heater the ideal selection.

STANDARD FEATURES

- 82+% Thermal Efficiency
- Redundant Single-Stage Gas Valve
- Residential Certification
- 120/24V Control Transformer
- OSHA Fan Guard
- 115/1/60 Fan Motor with Internal Overload Protection
- Direct Spark Ignition
- 20-Gauge Cabinet with Baked Enamel Finish
- 10 Year Heat Exchanger Warranty
- Right Hand Control Access - Field Convertible to Left Hand
- High Limit Switch
- Air Pressure Switch
- Natural or Propane Gas
- Gas Conversion Kit Included
- Field Convertible to Separated Combustion
- Easy Access Control Panel
- 321 Stainless Steel Burner Box
- 20-Gauge Aluminized Heat Exchanger
- Power Vented

OPTIONAL FEATURES

- 409 Stainless Steel Heat Exchanger
- Two-Stage Gas Control (Sizes 60-120 Only)
- Stainless Steel Flue Collector
- Supply Voltage (Field Mounted Transformers):
 - 208/1/60
 - 230/1/60
 - 208/3/60
 - 230/3/60
 - 460/3/60
 - 575/3/60
- Vent Caps
- Totally Enclosed Motors (Sizes 60-120 Only)
- Pressure Regulator (1/2 – 35 psi)
- Single & Two-Stage Mercury Free Thermostats
- Locking Thermostat Cover
- 24V SPST Relay
- Combustion Air Inlet Kits (For All Separated Combustion Installations)

Unit Number Description

Digit	G	X	X	X	—	1	2	3	4	5	6	7	8	9	10	11	12	13	14	15	+	
Item	Prefix <small>(Internal use Only)</small>					UT		CA			FT	FM	GT	AL	GC	SV	MT	DL		AS		

1, 2 - Unit Type [UT]

GG - Residential Low Profile Tubular Propeller
 Note: Field conversion to Separated Combustion requires a Combustion Air Inlet Kit. See Accessory Options X7-4 and X7-5 for proper unit selection.

3, 4, 5 - Capacity [CA]

- 030 - 30,000 BTU/HR
- 045 - 45,000 BTU/HR
- 060 - 60,000 BTU/HR
- 075 - 75,000 BTU/HR
- 090 - 90,000 BTU/HR
- 105 - 105,000 BTU/HR
- 120 - 120,000 BTU/HR

6 - Furnace Type [FT]

A - Right Hand Access

7 - Furnace Material [FM]*

- 1 - Standard (Aluminized) Steel
 - 2 - 409 Stainless Steel
- *Heat exchanger tube material only.

8 - Gas Type [GT]

- N - Natural Gas
- P - Propane (LP) Gas

9 - Altitude [AL]

- S - 0-4,999 feet
 - T - 5,000-11,999 feet
- Note: Installations over 2,000 feet require gas input deration in the field. Refer to unit installation instructions.

10 - Gas Control [GC]

- A - Single Stage (Standard)
- B - Two Stage (Capacities [CA] 060 through 120 only)

11 - Supply Voltage [SV]

- 1 - 115/1/60
 - 2 - 208/1/60
 - 3 - 230/1/60
 - 4 - 208/3/60
 - 5 - 230/3/60
 - 6 - 460/3/60
 - 7 - 575/3/60
 - Z - Special
- Note: Supply Voltage [SV] 2-7 include field mounted step down transformer.

12 - Motor Type [MT]

- 1 - Open Drip Proof (Standard)
- 2 - Totally Enclosed (Capacities [CA] 060 through 120 only)

13 - Development Level [DL]

C - Production Onset

14, 15+ - Accessories [AS]

FACTORY INSTALLED

- S3 - Stainless Steel Flue Collector
- Z1 - Special

All Field Installed Accessories are to be entered as a separate line item using catalog number which places "AS" as a prefix. i.e: A7 becomes AS-A7.

FIELD INSTALLED (AS-____)

- A7 - High Pressure Regulator
 - A7 - 1/2-1 Regulator for 0.5-10 PSI
 - A7 - 3/8-1 Regulator for 10-20 PSI
 - A7 - 5/16-1 Regulator for 20-35 PSI
- G1 - 1-Stage T87K Mercury Free Thermostat w/Subbase Kit
- G2 - 1-Stage T87K Mercury Free Thermostat w/TG511A Guard Kit
- G3 - 1-Stage T834N Mercury Free Thermostat/Fan Switch
- G5 - 2-Stage TH5220D Mercury Free Thermostat w/Subbase
- G6 - Locking Thermostat Cover
- G9 - 1-Stage T822K Mercury Free Thermostat

P5 - 24V SPST Relay-Specify Purpose

VC-4 - 4 inch Vent Cap

- X2 - 30 Degree Downturn Nozzle
- X3 - 60 Degree Downturn Nozzle
- X4 - 90 Degree Downturn Nozzle

- X7-4 - Combustion Air Inlet Kit (Capacities [CA] 030-075)
- X7-5 - Combustion Air Inlet Kit (Capacities [CA] 090-120)

GG Series — Low Profile Unit Heater Performance and Dimensional Data



UNIT CAPACITY (MBH)	30	45	60	75	90	105	120
PERFORMANCE DATA†							
Input - BTU/Hr (kW)	30,000 (8.8)	45,000 (13.2)	60,000 (17.6)	75,000 (22.0)	90,000 (26.4)	105,000 (30.8)	120,000 (35.2)
Output - BTU/Hr (kW)	24,900 (7.2)	37,350 (10.9)	49,800 (14.5)	61,500 (18.0)	73,800 (21.6)	86,100 (25.2)	98,400 (28.8)
Thermal Efficiency - %	83	83	83	82	82	82	82
Free Air Delivery - CFM (cu. m/s)	370 (.175)	550 (.260)	740 (.349)	920 (.434)	1,100 (.519)	1,300 (.614)	1,475 (.696)
Air Temperature Rise - °F (°C)	60 (15)	60 (15)	60 (15)	60 (15)	60 (15)	60 (15)	60 (15)
Full Load Amps at 120V	3.2	3.2	4.1	4.1	6.4	6.4	6.4
Minimum Circuit Ampacity at 120V	3.7	3.7	4.8	4.8	7.5	7.5	7.5
MOTOR DATA:							
Motor HP	1/20	1/20	1/12	1/12	1/10	1/10	1/10
Motor (kW)	(0.04)	(0.04)	(0.06)	(0.06)	(0.075)	(0.075)	(0.075)
Motor Type ODP††	SP	SP	SP	SP	SP	SP	SP
RPM	1650	1650	1050	1050	1050	1050	1050
Motor Amps @ 115V	1.9	1.9	2.6	2.6	4.2	4.2	4.2
DIMENSIONAL DATA - Inches (mm)							
"A" Jacket Height	12-3/8 (314)	12-3/8 (314)	15-7/8 (403)	15-7/8 (403)	22-5/8 (574)	22-5/8 (574)	22-5/8 (574)
"B" Overall Height	13-1/4 (337)	13-1/4 (337)	16-13/16 (427)	16-13/16 (427)	23-9/16 (598)	23-9/16 (598)	23-9/16 (598)
"C" Overall Depth	25-7/8 (632)	25-7/8 (632)	26-3/16 (665)	26-3/16 (665)	26-3/8 (670)	26-3/8 (670)	26-3/8 (670)
"D1" Center Line Height of Flue*	8-1/2 (216)	8-1/2 (216)	10-3/8 (263)	10-3/8 (263)	13-5/8 (346)	13-5/8 (346)	13-5/8 (346)
"D2" Center Line Height of Air Intake	8-1/2 (216)	8-1/2 (216)	8 (203)	8 (203)	8-5/8 (219)	8-5/8 (219)	8-5/8 (219)
"E" Fan Diameter	10 (254)	10 (254)	14 (356)	14 (356)	16 (406)	16 (406)	16 (406)
"F" Discharge Opening Height	10-13/16 (275)	10-13/16 (275)	14-7/16 (367)	14-7/16 (367)	21-3/16 (538)	21-3/16 (538)	21-3/16 (538)
"G" Vent Connection Diameter	4 (102)	4 (102)	4 (102)	4 (102)	4 (102)	4 (102)	4 (102)
"H1" Center Line of Flue Connection From Side	7-1/4 (184)	7-1/4 (184)	7-1/4 (184)	7-1/4 (184)	7-3/4 (197)	7-3/4 (197)	7-1/4 (184)
"H2" Center Line of Air Intake From Side	2-3/4 (70)	2-3/4 (70)	2-3/4 (70)	2-3/4 (70)	3-1/2 (89)	3-1/2 (89)	3-1/2 (89)
VENT SIZE REQUIREMENTS - STANDARD COMBUSTION							
Category III Horizontal - Inches (mm)	4 (102)	4 (102)	4 (102)	4 (102)	4 (102)	4 (102)	4 (102)
Category I & III Vertical - Inches (mm)	4 (102)	4 (102)	4 (102)	4 (102)	4 (102)	4 (102)	4 (102)
VENT SIZE REQUIREMENTS - SEPARATED COMBUSTION							
Exhaust Diameter** - Inches (mm)	4 (102)	4 (102)	4 (102)	4 (102)	5 (127)	5 (127)	5 (127)
Intake Air Diameter - Inches (mm)	4 (102)	4 (102)	4 (102)	4 (102)	5 (127)	5 (127)	5 (127)
Unit Weight - Lbs (kgs)	60 (27)	65 (29)	80 (36)	85 (39)	95 (43)	105 (48)	110 (50)
Shipping Weight - Lbs (kgs)	70 (32)	75 (34)	90 (41)	95 (43)	110 (50)	115 (52)	120 (54)

*For all installations, the flue collar is included with the unit and should be field installed per the instructions included with the unit.

**4-5 inch reducer supplied where required.

† Ratings shown are for unit installations at elevations between 0 and 2,000 feet (0 to 610m). For unit installations in USA above 2,000 feet (610m), the unit input must be field derated 4% for each 1,000 feet (305m) above sea level; refer to local codes, or in absence of local codes, refer to the latest edition of the National Fuel Gas Code, ANSI Standard Z223.1 (NFPA No. 54).

For installations in Canada, any reference to deration at altitudes in excess of 2,000 feet (610m) are to be ignored. At altitudes of 2,000 feet to 4,500 feet (610 to 1372m), the unit must be field derated and be so marked in accordance with the ETL certification. See unit installation, operation and maintenance manual for deration information.

†† LEGEND: ODP = OPEN DRIP PROOF SP = SHADED POLE

GG Series — Low Profile Unit Heater

Dimensional Data

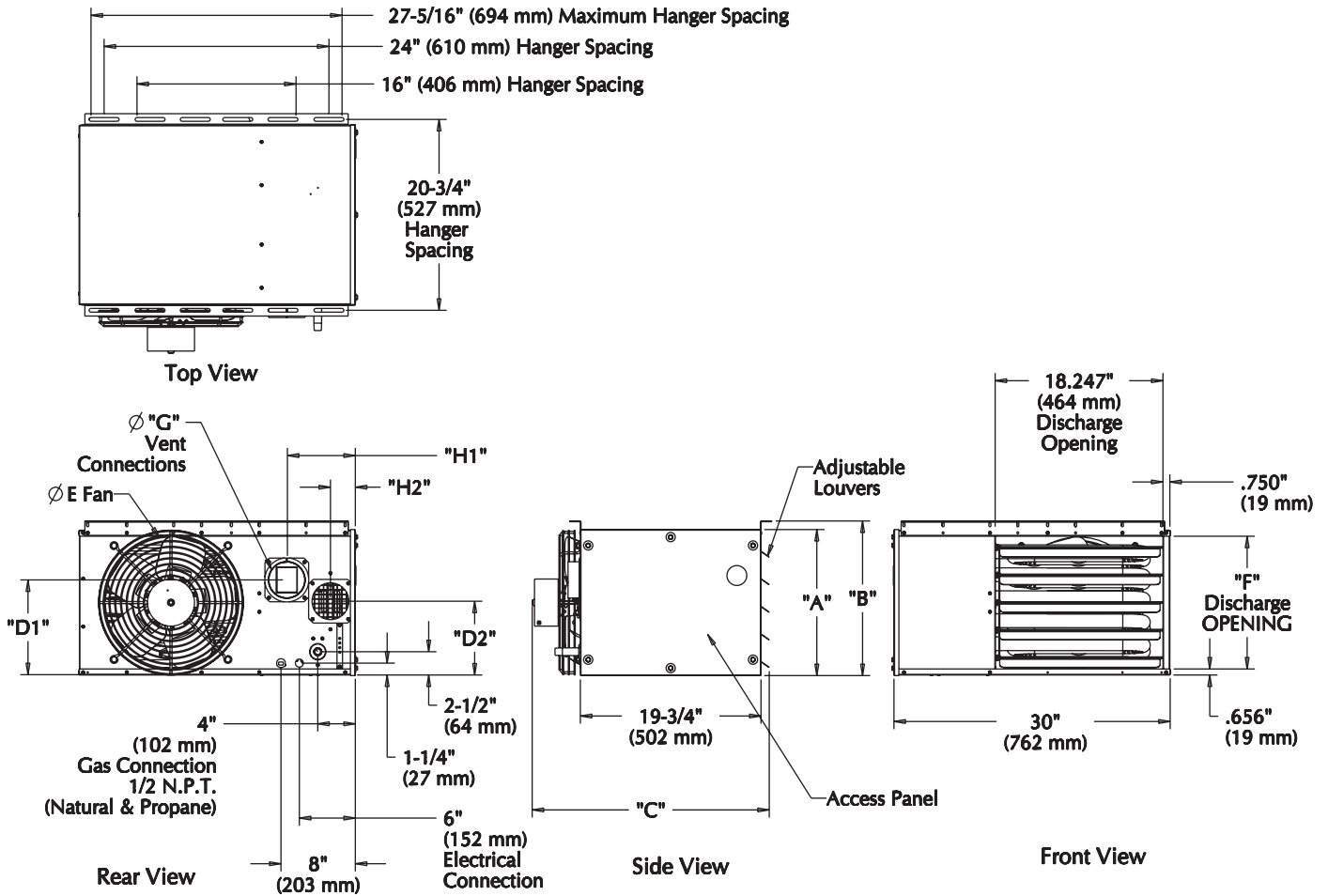

D8597

DIMENSIONS .XXX STANDARD UNITS
DIMENSIONS IN PARENTHESIS (XXX) MILLIMETERS

TF/TC Series — Tubular Unit Heater

STANDARD FEATURES

- In-Shot Burner Design
- 20-Gauge Steel Jacket with Baked Enamel Finish
- Main Control Panel
- 115/1/60 Supply Voltage
- Direct Spark Ignition
- Redundant Single-Stage Gas Valve
- 115/24 Volt Control Transformer
- Individually Adjustable and Removable Louvers
- Power Vented
- 115/1/60 Volt Motor with Internal Overload Protection
- 10 Year Heat Exchanger, Flue Collector and Burner Warranty
- 82+% Thermal Efficiency

OPTIONAL FEATURES

- Stainless Steel Heat Exchanger, Burners and/or Flue Collector
- Supply Voltages: 208 & 230/1/60 and 230, 460, 575/3/60
- Premium Efficiency Blower Motors in ODP and TE Types
- Two-Stage and Various Electronic Modulation Gas Controls
- Discharge Nozzles (30°, 60° & 90°) or Duct Flange Assembly

Unit Number Description

TF Series

Digit	T	X	X	X	—	1	2	3	4	5	6	7	8	9	10	11	12	13	+
Item	Prefix (Internal use Only)					UT		CA			FT	FM	GT	AL	GC	SV	MT	AS	

TC Series

Digit	T	X	X	X	—	1	2	3	4	5	6	7	8	9	10	11	12	13	14	+
Item	Prefix (Internal use Only)					UT		CA			FT	FM	GT	AL	GC	SV	MT	MS	AS	

1, 2 - Unit Type [UT]

TF - Tubular Propeller
TC - Tubular Blower

3, 4, 5 - Capacity [CA]

100 - 100,000 BTU/HR
125 - 125,000 BTU/HR
150 - 150,000 BTU/HR
175 - 175,000 BTU/HR
200 - 200,000 BTU/HR
250 - 250,000 BTU/HR
300 - 300,000 BTU/HR
350 - 350,000 BTU/HR
400 - 400,000 BTU/HR

6 - Furnace Type [FT]

A - Right Side Access

7 - Heat Exchanger Construction Material [FM]

1 - Standard (Aluminized) Steel
2 - 409 Stainless Steel

8 - Gas Type [GT]

N - Natural Gas
P - Propane Gas (LP)

9 - Altitude [AL]

S - 0-4,999 feet
T - 5,000-11,999 feet
Note: Installations over 2,000 feet require gas input deration in the field. Refer to unit installation instructions.

10 - Direct Spark Gas Control [GC]

1 - Single Stage
2 - Two Stage
3 - Electronic Modulation w/Room Sensing
4 - Electronic Modulation w/Duct Sensing (Blower only)
5 - Electronic Modulation w/Duct Sensing & Room Ovrd. Stat (Blower only)
6 - Electronic Modulation w/External 4-20 mA Input
7 - Electronic Modulation w/External 0-10 VDC Input

11 - Supply Voltage [SV]

1 - 115/1/60
2 - 208/1/60
3 - 230/1/60
4 - 208/3/60
5 - 230/3/60
6 - 460/3/60
7 - 575/3/60
Z - Special

Note: Supply Voltages [SV] 2-7 include step down transformer. Field mounted for propeller units, factory mounted for blower units.

12 - Motor Type [MT]

1 - Open Drip Proof (Standard)
2 - Totally Enclosed
3 - Premium Efficiency, Open Drip Proof (Blowers only)
4 - Premium Efficiency, Totally Enclosed (Blowers only)

13 - Blower Motor Sizes [MS]**

A - 1/4 HP w/Contactor
C - 1/2 HP w/Contactor
D - 3/4 HP w/Contactor
F - 1 HP w/Contactor
G - 1-1/2 HP w/Contactor
H - 2 HP w/Contactor
J - 1/4 HP
L - 1/2 HP
P - 1/2 HP w/Magnetic Starter
R - 3/4 HP w/Magnetic Starter
S - 1 HP w/Magnetic Starter
T - 1-1/2 HP w/Magnetic Starter
U - 2 HP w/Magnetic Starter
W - 1/4 HP w/Magnetic Starter

**Notes: 1. All 3-phase units [SV = 4, 5, 6, 7] include a contactor as standard.
2. All single phase units [SV = 1, 2, 3] include a contactor for units equipped with 3/4 HP motor or higher [MS =D, F, G, H]
3. [MS] options J, L only available with [SV] option 1 (115/1/60).

13/14 - Accessories [AS]

FACTORY INSTALLED

M6 - OSHA Type Fan Guard (Propellers only)
M8 - Discharge Duct Flange Assembly (Blowers only)
P4 - Terminal Block Wiring
P6 - Summer/Winter Switch
S3 - 409 Stainless Steel Flue Collector
S5 - 304L Stainless Steel Burners

† FIELD INSTALLED (AS-____)

† All Field Installed Accessories are to be entered as a separate line item using catalog number which utilizes "AS" as a prefix. i.e: A7 becomes AS-A7.

A7 - High Pressure Regulator

A7 - 1/2-1 Regulator for 0.5-10 PSI
A7 - 3/8-1 Regulator for 10-20 PSI
A7 - 5/16-1 Regulator for 20-35 PSI

H5 - Low Ambient Control

M2-2 - Vent Caps (5 inch) (Unit Capacity 100-250)
M2-3 - Vent Caps (6 inch) (Unit Capacity 300-400)
M7 - 2 to 4 Point Suspension Kit (Propeller Only)

F1 - 1-Stage T675A Ductstat (Blower only)

F2 - 2-Stage T678A Ductstat (Blower only)

P5 - 24V SPST Relay-Specify Purpose

G1 - 1-Stage T87K Mercury Free Thermostat w/Subbase Kit

G2 - 1-Stage T87K Mercury Free Thermostat w/TG511A Guard Kit

G3 - 1-Stage T834N Mercury Free Thermostat/Fan Switch

G5 - 2-Stage TH5220D Mercury Free Thermostat w/Subbase

G6 - Locking Thermostat Cover

G9 - 1-Stage T822K Mercury Free Thermostat

X2 - 30 Degree Downturn Nozzle

X3 - 60 Degree Downturn Nozzle

X4 - 90 Degree Downturn Nozzle

X5 - Vertical Louver Kit

TF Series — Tubular Propeller Unit Heater

Performance and Dimensional Data



UNIT CAPACITY (MBH)	100	125	150	175	200	250	300	350	400
PERFORMANCE DATA†									
Input - BTU/Hr (kW)	100,000 (29.3)	125,000 (36.6)	150,000 (43.9)	175,000 (51.2)	200,000 (58.6)	250,000 (73.2)	300,000 (87.8)	350,000 (102.5)	400,000 (117.1)
Output - BTU/Hr (kW)	83,000 (24.3)	103,750 (30.4)	124,500 (36.4)	145,250 (42.5)	166,000 (48.6)	207,500 (60.7)	249,000 (72.9)	290,500 (85.1)	332,000 (97.2)
Thermal Efficiency - %	83	83	83	83	83	83	83	83	83
Free Air Delivery - CFM (cu. m/s)	1,600 (0.756)	2,200 (1.039)	2,400 (1.133)	2,850 (1.346)	3,200 (1.511)	3,450 (1.629)	5,000 (2.361)	5,600 (2.644)	5,800 (2.738)
Air Temperature Rise - °F (°C)	47 (26)	42 (23)	47 (26)	46 (26)	47 (26)	54 (30)	45 (24)	47 (26)	51 (28)
Full Load Amps at 120V	6.4	6.9	6.9	8.0	8.0	8.0	11.6	13.8	13.8
Minimum Circuit Amps at 120V	7.5	8.1	8.1	9.5	9.5	9.5	14.0	16.7	16.7
MOTOR DATA:									
Motor HP (Qty)	1/10	1/4	1/4	1/3	1/3	1/3	1/4 (2)	1/3 (2)	1/3 (2)
Motor kW	(0.080)	(0.19)	(0.19)	(0.25)	(0.25)	(0.25)	(0.19)	(0.25)	(0.25)
Motor Type ODP**	SP	PSC	PSC	PSC	PSC	PSC	PSC	PSC	PSC
RPM	1,050	1,140	1,140	1,140	1,140	1,140	1,140	1,140	1,140
Amps @ 115V	4.2	4.7	4.7	5.8	5.8	5.8	9.4	11.6	11.6
DIMENSIONAL DATA - Inches (mm)									
"A" Overall Height to Top of Flue	33-3/4 (857)	33-3/4 (857)	33-3/4 (857)	33-3/4 (857)	33-3/4 (857)	33-3/4 (857)	34 (864)	34 (864)	34 (864)
"B" Jacket Width of Unit	20-3/4 (527)	20-3/4 (527)	20-3/4 (527)	32-3/4 (831)	32-3/4 (831)	32-3/4 (831)	50-3/4 (1289)	50-3/4 (1289)	50-3/4 (1289)
"C" Width to CL Flue	13-3/8 (340)	13-3/8 (340)	13-3/8 (340)	19-3/8 (492)	19-3/8 (492)	19-3/8 (492)	28-3/8 (721)	28-3/8 (721)	28-3/8 (721)
"D" Depth to Rear of Housing	11 (279)	11 (279)	11 (279)	11 (279)	11 (279)	11 (279)	12-1/4 (311)	12-1/4 (311)	12-1/4 (311)
"E" Hanging Distance Width	18-5/8 (473)	18-5/8 (473)	18-5/8 (473)	30-5/8 (778)	30-5/8 (778)	30-5/8 (778)	48-5/8 (1235)	48-5/8 (1235)	48-5/8 (1235)
"F" Discharge Opening Width	18-3/4 (476)	18-3/4 (476)	18-3/4 (476)	30-3/4 (781)	30-3/4 (781)	30-3/4 (781)	48-3/4 (1238)	48-3/4 (1238)	48-3/4 (1238)
"G" Depth to CL Flue	4-3/4 (121)	4-3/4 (121)	4-3/4 (121)	4-3/4 (121)	4-3/4 (121)	4-3/4 (121)	5-1/8 (130)	5-1/8 (130)	5-1/8 (130)
"H" Discharge Opening Height	24-1/2 (622)	24-1/2 (622)	24-1/2 (622)	24-1/2 (622)	24-1/2 (622)	24-1/2 (622)	24-1/2 (622)	24-1/2 (622)	24-1/2 (622)
"L" Overall Unit Width	25-1/4 (641)	25-1/4 (641)	25-1/4 (641)	37-1/4 (946)	37-1/4 (946)	37-1/4 (946)	55-1/4 (1403)	55-1/4 (1403)	55-1/4 (1403)
"M" Flue Size Diameter* - Inches (mm)	5 (127)	5 (127)	5 (127)	5 (127)	5 (127)	5 (127)	6 (152)	6 (152)	6 (152)
Fan Diameter - Inches (Qty)	16	16	16	18	18	18	16 (2)	18 (2)	18 (2)
Gas Inlet, Natural Gas - Inches	1/2	1/2	1/2	1/2	1/2	3/4	3/4	3/4	3/4
Gas Inlet, LP Gas - Inches	1/2	1/2	1/2	1/2	1/2	3/4	3/4	3/4	3/4
Approximate Unit Weight - Lbs (kg)	133 (60)	145 (66)	155 (70)	191 (87)	201 (91)	211 (96)	307 (139)	321 (145)	335 (152)
Approximate Ship Weight - Lbs (kg)	173 (78)	185 (84)	195 (88)	241 (109)	251 (114)	261 (118)	367 (166)	381 (173)	395 (179)

† Ratings shown are for unit installations at elevations between 0 and 2,000 feet (0 to 610m). For unit installations in USA above 2,000 feet (610m), the unit input must be field derated 4% for each 1,000 feet (305m) above sea level; refer to local codes, or in absence of local codes, refer to the latest edition of the National Fuel Gas Code, ANSI Standard Z223.1 (NFPA No. 54).

For installations in Canada, any reference to deration at altitudes in excess of 2,000 feet (610m) are to be ignored. At altitudes of 2,000 feet to 4,500 feet (610 to 1372m), the unit must be field derated and be so marked in accordance with the ETL certification. See unit installation, operation and maintenance manual for deration information.

* Flue collar is factory supplied with unit; to be field installed per included instructions. ** LEGEND: SP = SHADED POLE PSC = PERMANENT SPLIT CAPACITOR ODP = OPEN DRIP PROOF

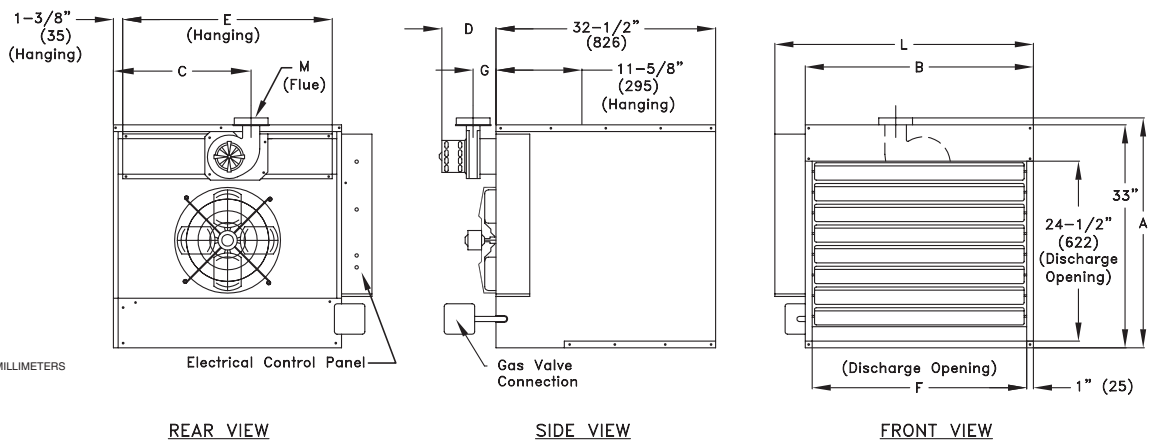

D4617C
 DIMENSIONS: .XXX STANDARD UNITS
 DIMENSIONS IN PARENTHESIS (XXX) MILLIMETERS

TC Series — Tubular Blower Unit Heater

Performance and Dimensional Data



UNIT CAPACITY (MBH)	100	125	150	175	200	250	300	350	400
PERFORMANCE DATA†									
Input - BTU/Hr (kW)	100,000 (29.3)	125,000 (36.6)	150,000 (44.0)	175,000 (51.3)	200,000 (58.6)	250,000 (73.3)	300,000 (87.9)	350,000 (102.6)	400,000 (117.2)
Output - BTU/Hr (kW)	83,000 (24.3)	103,750 (30.4)	124,500 (36.5)	145,250 (42.6)	166,000 (48.6)	207,500 (60.8)	246,000 (72.1)	290,500 (85.1)	332,000 (97.3)
Thermal Efficiency - %	83	83	83	83	83	83	82	83	83
Free Air Delivery - CFM (cu. m/s)	1,181 (0.557)	1,476 (0.697)	1,771 (0.836)	2,067 (0.976)	2,362 (1.115)	2,953 (1.394)	3,501 (1.652)	4,134 (1.951)	4,724 (2.230)
Air Temperature Rise - °F (°C)	65 (36)	65 (36)	65 (36)	65 (36)	65 (36)	65 (36)	65 (36)	65 (36)	65 (36)
Outlet Velocity - FPM (m/s)	370 (1.879)	463 (2.351)	555 (2.819)	395.0 (2.006)	451.0 (2.291)	564.0 (2.864)	422 (2.143)	498 (2.529)	570 (2.895)
Full Load Amps at 115V	7.3	9.4	9.4	14.2	14.2	15.6	15.6	20.8	20.8
Minimum Circuit Ampacity at 115V	8.6	11.2	11.2	17.1	17.1	18.9	18.9	25.4	25.4
MOTOR DATA									
Motor HP	1/4	1/2	1/2	3/4	3/4	1	1	1-1/2	1-1/2
Motor kW	0.19	0.37	0.37	0.56	0.56	0.75	0.75	1.11	1.11
Motor Type ODP**	SPH	SPH	SPH	SPH	SPH	Cap. Start	Cap. Start	Cap. Start	Cap. Start
RPM	1,725	1,725	1,725	1,725	1,725	1,725	1,725	1,725	1,725
Amps @ 115V	5.1	7.2	7.2	11.6	11.6	13.0	13.0	18.2	18.2
DIMENSIONAL DATA - Inches (mm)									
"A" Height to Top of Flue	33-3/4 (857)	33-3/4 (857)	33-3/4 (857)	33-3/4 (857)	33-3/4 (857)	33-3/4 (857)	34 (864)	34 (864)	34 (864)
"B" Jacket Width of Unit	20-3/4 (527)	20-3/4 (527)	20-3/4 (527)	32-3/4 (832)	32-3/4 (832)	32-3/4 (832)	50-3/4 (1289)	50-3/4 (1289)	50-3/4 (1289)
"C" Width to Centerline Flue	13-3/8 (340)	13-3/8 (340)	13-3/8 (340)	19-3/8 (492)	19-3/8 (492)	19-3/8 (492)	28-3/8 (721)	28-3/8 (721)	28-3/8 (721)
"D" Depth to Front Hanger	21 (533)	21 (533)	21 (533)	21 (533)	21 (533)	21 (533)	21 (533)	21 (533)	21 (533)
"E" Hanging Distance Width	18-5/8 (473)	18-5/8 (473)	18-5/8 (473)	30-5/8 (778)	30-5/8 (778)	30-5/8 (778)	48-5/8 (1235)	48-5/8 (1235)	48-5/8 (1235)
"F" Hanging Distance Depth	19 (483)	19-1/2 (495)	19-1/2 (495)	32-3/4 (832)	32-3/4 (832)	32-3/4 (832)	23-1/2 (597)	32-3/4 (832)	32-3/4 (832)
"G" Discharge Opening Width	18-3/4 (476)	18-3/4 (476)	18-3/4 (476)	30-3/4 (781)	30-3/4 (781)	30-3/4 (781)	48-3/4 (1238)	48-3/4 (1238)	48-3/4 (1238)
"H" Depth to Centerline Flue	4-3/4 (121)	4-3/4 (121)	4-3/4 (121)	4-3/4 (121)	4-3/4 (121)	4-3/4 (121)	5-1/8 (130)	5-1/8 (130)	5-1/8 (130)
"L" Discharge Opening Height	24-1/2 (622)	24-1/2 (622)	24-1/2 (622)	24-1/2 (622)	24-1/2 (622)	24-1/2 (622)	24-1/2 (622)	24-1/2 (622)	24-1/2 (622)
"M" Overall Unit Width	25-1/4 (641)	25-1/4 (641)	25-1/4 (641)	37-1/4 (946)	37-1/4 (946)	37-1/4 (946)	55-1/4 (1403)	55-1/4 (1403)	55-1/4 (1403)
"P" Overall Unit Depth	49-3/4 (1264)	49-3/8 (1254)	49-3/8 (1254)	56-1/8 (1426)	56-1/8 (1426)	56-1/8 (1426)	53-3/8 (1356)	56-1/8 (1426)	56-1/8 (1426)
*Flue Size Diameter - Inches (mm)	5 (127)	5 (127)	5 (127)	5 (127)	5 (127)	5 (127)	6 (152)	6 (152)	6 (152)
Blower Size - Inches (Qty)	9	10	10	12	12	12	10 (2)	12 (2)	12 (2)
Gas Inlet, Natural Gas - Inches	1/2	1/2	1/2	1/2	1/2	1/2	3/4	3/4	3/4
Gas Inlet, LP Gas - Inches	1/2	1/2	1/2	1/2	1/2	1/2	3/4	3/4	3/4
Approximate Unit Weight - Lbs (kg)	171 (78)	175 (79)	202 (92)	245 (111)	264 (120)	289 (131)	370 (168)	390 (177)	429 (195)
Approximate Ship Weight - Lbs (kg)	256 (116)	261 (118)	289 (131)	381 (173)	400 (181)	425 (193)	520 (236)	547 (248)	595 (270)

† Ratings shown are for unit installations at elevations between 0 and 2,000 feet (0 to 610m). For unit installations in USA above 2,000 feet (610m), the unit input must be field derated 4% for each 1,000 feet (305m) above sea level; refer to local codes, or in absence of local codes, refer to the latest edition of the National Fuel Gas Code, ANSI Standard Z223.1 (NFPA No. 54).

For installations in Canada, any reference to deration at altitudes in excess of 2,000 feet (610m) are to be ignored. At altitudes of 2,000 feet to 4,500 feet (610 to 1372m), the unit must be field derated and be so marked in accordance with the ETL certification. See unit installation, operation and maintenance manual for deration information.

* Flue collar is factory supplied with unit; to be field installed per included instructions.

** LEGEND: SPH = SPLIT PHASE
CAP. START = CAPACITOR START
ODP = OPEN DRIP PROOF

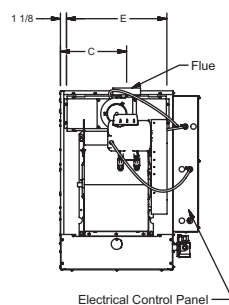

Rear View

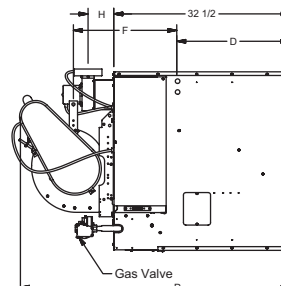

Side View

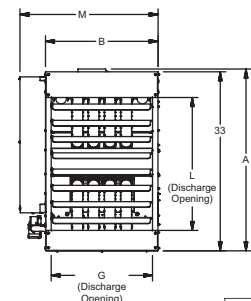

Front View

D8931B

TC Series — Tubular Blower Unit Heater Performance Data

Unit	Temp.Rise °F (°C)	CFM (cu. m/s)	External Static Pressure Inches WC (kPa)									
			0.1" (0.02)		0.2" (0.05)		0.3" (0.07)		0.4" (0.10)		0.5" (0.12)	
			RPM	HP (kW)	RPM	HP (kW)	RPM	HP (kW)	RPM	HP (kW)	RPM	HP (kW)
TC100	50 (10)	1535 (0.724)	804	1/2 (0.37)	860	1/2 (0.37)	927	1/2 (0.37)	989	1/2 (0.37)	1045	1/2 (0.37)
	60 (15.5)	1279 (0.603)	649	1/4 (0.19)	760	1/4 (0.19)	821	1/4 (0.19)	890	1/4 (0.19)	963	1/4 (0.19)
	70 (21.1)	1096 (0.517)	633	1/4 (0.19)	700	1/4 (0.19)	779	1/4 (0.19)	858	1/4 (0.19)	920	1/4 (0.19)
	80 (26.6)	959 (0.452)	591	1/4 (0.19)	665	1/4 (0.19)	733	1/4 (0.19)	801	1/4 (0.19)	869	1/4 (0.19)
TC125	50 (10)	1919 (0.905)	703	1/2 (0.37)	758	1/2 (0.37)	810	1/2 (0.37)	863	1/2 (0.37)	918	1/2 (0.37)
	60 (15.5)	1599 (0.754)	608	1/2 (0.37)	685	1/2 (0.37)	741	1/2 (0.37)	790	1/2 (0.37)	843	1/2 (0.37)
	70 (21.1)	1371 (0.647)	558	1/2 (0.37)	626	1/2 (0.37)	694	1/2 (0.37)	755	1/2 (0.37)	798	1/2 (0.37)
	80 (26.6)	1199 (0.565)	580	1/2 (0.37)	597	1/2 (0.37)	649	1/2 (0.37)	720	1/2 (0.37)	779	1/2 (0.37)
TC150	50 (10)	2303 (1.087)	853	1/2 (0.37)	927	1/2 (0.37)	962	1/2 (0.37)	988	1/2 (0.37)	1040	1/2 (0.37)
	60 (15.5)	1919 (0.905)	755	1/2 (0.37)	810	1/2 (0.37)	845	1/2 (0.37)	894	1/2 (0.37)	939	1/2 (0.37)
	70 (21.1)	1645 (0.776)	649	1/2 (0.37)	726	1/2 (0.37)	790	1/2 (0.37)	836	1/2 (0.37)	876	1/2 (0.37)
	80 (26.6)	1439 (0.679)	616	1/2 (0.37)	670	1/2 (0.37)	720	1/2 (0.37)	785	1/2 (0.37)	840	1/2 (0.37)
TC175	50 (10)	2687 (1.26)	522	3/4 (0.56)	566	3/4 (0.56)	612	3/4 (0.56)	652	3/4 (0.56)	688	3/4 (0.56)
	60 (15.5)	2239 (1.05)	468	3/4 (0.56)	514	3/4 (0.56)	564	3/4 (0.56)	609	3/4 (0.56)	654	3/4 (0.56)
	70 (21.1)	1919 (0.905)	423	3/4 (0.56)	471	3/4 (0.56)	527	3/4 (0.56)	582	3/4 (0.56)	624	3/4 (0.56)
	80 (26.6)	1697 (0.8)	402	3/4 (0.56)	482	3/4 (0.56)	515	3/4 (0.56)	567	3/4 (0.56)	609	3/4 (0.56)
TC200	50 (10)	3071 (1.44)	592	3/4 (0.56)	627	3/4 (0.56)	670	3/4 (0.56)	702	3/4 (0.56)	748	3/4 (0.56)
	60 (15.5)	2559 (1.2)	526	3/4 (0.56)	561	3/4 (0.56)	597	3/4 (0.56)	647	3/4 (0.56)	688	3/4 (0.56)
	70 (21.1)	2193 (1.03)	468	3/4 (0.56)	519	3/4 (0.56)	556	3/4 (0.56)	612	3/4 (0.56)	653	3/4 (0.56)
	80 (26.6)	1919 (0.905)	432	3/4 (0.56)	481	3/4 (0.56)	537	3/4 (0.56)	593	3/4 (0.56)	638	3/4 (0.56)
TC250	50 (10)	3839 (1.81)	734	1 (0.75)	766	1 (0.75)	802	1 1/2 (1.11)	836	1 1/2 (1.11)	863	1 1/2 (1.11)
	60 (15.5)	3199 (1.51)	626	1 (0.75)	668	1 (0.75)	700	1 (0.75)	749	1 (0.75)	780	1 (0.75)
	70 (21.1)	2742 (1.29)	545	1 (0.75)	593	1 (0.75)	633	1 (0.75)	680	1 (0.75)	718	1 (0.75)
	80 (26.6)	2399 (1.13)	494	1 (0.75)	555	1 (0.75)	590	1 (0.75)	642	1 (0.75)	680	1 (0.75)
TC300	50 (10)	4551 (2.14)	734	1 (0.75)	766	1 (0.75)	802	1 1/2 (1.11)	836	1 1/2 (1.11)	863	1 1/2 (1.11)
	60 (15.5)	3792 (1.79)	626	1 (0.75)	668	1 (0.75)	700	1 (0.75)	749	1 (0.75)	780	1 (0.75)
	70 (21.1)	3259 (1.53)	545	1 (0.75)	593	1 (0.75)	633	1 (0.75)	680	1 (0.75)	718	1 (0.75)
	80 (26.6)	2844 (1.34)	494	1 (0.75)	555	1 (0.75)	590	1 (0.75)	642	1 (0.75)	680	1 (0.75)
TC350	50 (10)	5374 (2.54)	558	1 1/2 (1.11)	598	1 1/2 (1.11)	638	1 1/2 (1.11)	676	1 1/2 (1.11)	727	1 1/2 (1.11)
	60 (15.5)	4478 (2.11)	484	1 1/2 (1.11)	532	1 1/2 (1.11)	588	1 1/2 (1.11)	653	1 1/2 (1.11)	680	1 1/2 (1.11)
	70 (21.1)	3839 (1.81)	451	1 1/2 (1.11)	503	1 1/2 (1.11)	559	1 1/2 (1.11)	609	1 1/2 (1.11)	654	1 1/2 (1.11)
	80 (26.6)	3359 (1.59)	408	1 1/2 (1.11)	480	1 1/2 (1.11)	536	1 1/2 (1.11)	589	1 1/2 (1.11)	621	1 1/2 (1.11)
TC400	50 (10)	6142 (2.9)	647	1 1/2 (1.11)	659	1 1/2 (1.11)	670	1 1/2 (1.11)	713	1 1/2 (1.11)	751	2 (1.49)
	60 (15.5)	5118 (2.41)	553	1 1/2 (1.11)	570	1 1/2 (1.11)	618	1 1/2 (1.11)	653	1 1/2 (1.11)	697	1 1/2 (1.11)
	70 (21.1)	4387 (2.07)	483	1 1/2 (1.11)	523	1 1/2 (1.11)	568	1 1/2 (1.11)	615	1 1/2 (1.11)	660	1 1/2 (1.11)
	80 (26.6)	3839 (1.81)	437	1 1/2 (1.11)	490	1 1/2 (1.11)	547	1 1/2 (1.11)	589	1 1/2 (1.11)	655	1 1/2 (1.11)

SF/SC Series — Separated Combustion Unit Heater

STANDARD FEATURES

- Enclosed Combustion System
- 20-Gauge Aluminized Steel Tubular Heat Exchanger
- 115/24 Volt Control Transformer
- 83% Thermal Efficiency
- Combustion Air Pressure Switch
- ODP Motor (with Overload Protection)
- Redundant Single-Stage Gas Valve
- 20-Gauge Steel Cabinetry with Baked Enamel Finish
- Direct Spark Ignition System
- 115/1/60 Supply Voltage
- Rear Burner Access
- Power Vented
- Individually Adjustable and Removable Horizontal Louvers
- Complete Belt/Fan Guard
- Main Control Panel
- 10 Year Heat Exchanger, Flue Collector and Burner Warranty

OPTIONAL FEATURES

- Stainless Steel Heat Exchanger, Burners, and/or Flue Collector
- Supply Voltages: 208 & 230/1/60 and 208, 230, 460, 575/3/60
- Two-Stage and Various Electronic Modulation Gas Controls
- Premium Efficiency Blower Motors in ODP & TE Types
- Discharge Nozzles (30°, 60° & 90°) or Duct Flange Assembly
- Combustion Air Inlet Kits (allows concentric venting with horizontal or vertical termination)

Unit Number Description

Digit	T	X	X	X	—	1	2	3	4	5	6	7	8	9	10	11	12	13	14	+
Item	Prefix					UT	CA			FT	FM	GT	AL	GC	SV	MT	MS	AS		
	(Internal use Only)																			

1, 2 - Unit Type [UT]

SF - Separated Combustion Tubular Propeller
SC - Separated Combustion Tubular Blower

3, 4, 5 - Capacity [CA]

100 - 100,000 BTU/HR
125 - 125,000 BTU/HR
150 - 150,000 BTU/HR
175 - 175,000 BTU/HR
200 - 200,000 BTU/HR
250 - 250,000 BTU/HR
300 - 300,000 BTU/HR
350 - 350,000 BTU/HR
400 - 400,000 BTU/HR

6 - Furnace Type [FT]

A - Right Side Access

7 - Heat Exchanger Construction Material [FM]

1 - Standard (Aluminized) Steel
2 - 409 Stainless Steel

8 - Gas Type [GT]

N - Natural Gas
P - Propane Gas (LP)

9 - Altitude [AL]

S - 0-4,999 feet
T - 5,000-11,999 feet

Note: Installations over 2,000 feet require gas input deration in the field. Refer to unit installation instructions.

10 - Direct Spark Gas Control [GC]

1 - Single Stage
2 - Two Stage
3 - Electronic Modulation w/Room Sensing
4 - Electronic Modulation w/Duct Sensing (Blower only)
5 - Electronic Modulation w/Duct Sensing & Room Ovrd. Stat (Blower only)
6 - Electronic Modulation w/External 4-20 mA Input
7 - Electronic Modulation w/External 0-10 VDC Input

11 - Supply Voltage [SV]

1 - 115/1/60 5 - 230/3/60
2 - 208/1/60 6 - 460/3/60
3 - 230/1/60 7 - 575/3/60
4 - 208/3/60 Z - Special

Note: Supply Voltages [SV] 2-7 include step down transformer. Field mounted for propeller units, factory mounted for blower units.

12 - Motor Type [MT]

1 - Open Drip Proof (Standard)
2 - Totally Enclosed
3 - Premium Efficiency, Open Drip Proof (Blowers Only)
4 - Premium Efficiency, Totally Enclosed (Blowers Only)

13 - Blower Motor Sizes [MS]**

A - 1/4 HP w/Contactor P - 1/2 HP w/Magnetic Starter
C - 1/2 HP w/Contactor R - 3/4 HP w/Magnetic Starter
D - 3/4 HP w/Contactor S - 1 HP w/Magnetic Starter
F - 1 HP w/Contactor T - 1-1/2 HP w/Magnetic Starter
G - 1-1/2 HP w/Contactor U - 2 HP w/Magnetic Starter
H - 2 HP w/Contactor W - 1/4 HP w/Magnetic Starter
J - 1/4 HP O - None/Not Applicable
L - 1/2 HP

**Notes: 1. All 3-phase units [SV = 4, 5, 6, 7] include a contactor as standard.
2. All single phase units [SV = 1, 2, 3] include a contactor for units equipped with 3/4 HP. motor or higher [MS = D, F, G, H]
3. [MS] options J, L only available with [SV] option 1 (115/1/60).

14 - Accessories [AS]

FACTORY INSTALLED

M6 - OSHA Type Fan Guard (Propellers Only)
M8 - Discharge Duct Flange (Blowers Only)
P4 - Terminal Block Wiring
P6 - Summer/Winter Switch
S3 - 409 Stainless Steel Flue Collector
S5 - 304L Stainless Steel Burners

† FIELD INSTALLED (AS-____)

† All Field Installed Accessories are to be entered as a separate line item using catalog number which utilizes "AS" as a prefix x. i.e: A7 becomes AS-A7.

A7 - High Pressure Regulator
A7 - 1/2-1 Regulator for 0.5-10 PSI
A7 - 3/8-1 Regulator for 10-20 PSI
A7 - 5/16-1 Regulator for 20-35 PSI

F1 - 1-Stage T675A Ductstat (Blowers Only)
F2 - 2-Stage T678A Ductstat (Blowers Only)

G1 - 1-Stage T87K Mercury Free Thermostat w/Subbase Kit
G2 - 1-Stage T87K Mercury Free Thermostat w/TG511A Guard Kit
G3 - 1-Stage T834N Mercury Free Thermostat/Fan Switch
G5 - 2-Stage TH5220D Mercury Free Thermostat w/Subbase
G6 - Locking Thermostat Cover
G9 - 1-Stage T822K Mercury Free Thermostat

H5 - Low Ambient Control
M2-2 - Vent Caps (5 inch) (Unit Capacity 100-250)
M2-3 - Vent Caps (6 inch) (Unit Capacity 300-400)
M7 - 2 to 4 Point Suspension Kit (Propellers Only)
P5 - 24V SPST Relay-Specify Purpose
P5 - 24V SPST Relay-Specify Purpose
X3 - 60 Degree Downturn Nozzle
X4 - 90 Degree Downturn Nozzle
X5 - Vertical Louver Kit
X7-H5 - Horiz. Combustion Air Inlet Kit, 5 inch (Unit Capacity 100-250)
X7-H6 - Horiz. Combustion Air Inlet Kit, 6 inch (Unit Capacity 300-400)
X7-V5 - Vert. Combustion Air Inlet Kit, 5 inch (Unit Capacity 100-250)
X7-V6 - Vert. Combustion Air Inlet Kit, 6 inch (Unit Capacity 300-400)

SF Series — Separated Combustion Propeller Performance and Dimensional Data



UNIT CAPACITY (MBH)	100	125	150	175	200	250	300	350	400
PERFORMANCE DATA†									
Input - BTU/Hr (kW)	100,000 (29.3)	125,000 (36.6)	150,000 (43.9)	175,000 (51.2)	200,000 (58.6)	250,000 (73.2)	300,000 (87.8)	350,000 (102.5)	400,000 (117.1)
Output - BTU/Hr (kW)	83,000 (24.3)	103,750 (30.4)	124,500 (36.4)	145,250 (42.5)	166,000 (48.6)	207,500 (60.7)	249,000 (72.9)	290,500 (85.1)	332,000 (97.2)
Thermal Efficiency - %	83	83	83	83	83	83	83	83	83
Free Air Delivery - CFM (cu. m/s)	1,600 (0.756)	2,200 (1.039)	2,400 (1.133)	2,850 (1.346)	3,200 (1.511)	3,450 (1.629)	5,000 (2.361)	5,600 (2.644)	5,800 (2.738)
Air Temperature Rise - °F (°C)	47 (26)	42 (23)	47 (26)	46 (26)	47 (26)	54 (30)	45 (24)	47 (26)	51 (28)
Full Load Amps at 120V	6.4	6.9	6.9	8.0	8.0	8.0	11.6	13.8	13.8
Minimum Circuit Amps at 120V	7.5	8.1	8.1	9.5	9.5	9.5	14	16.7	16.7
MOTOR DATA:									
Motor HP (Qty)	1/10	1/4	1/4	1/3	1/3	1/3	1/4 (2)	1/3 (2)	1/3 (2)
Motor kW	(0.080)	(0.19)	(0.19)	(0.25)	(0.25)	(0.25)	(0.19)	(0.25)	(0.25)
Motor Type ODP**	SP	PSC	PSC	PSC	PSC	PSC	PSC	PSC	PSC
RPM	1,050	1,140	1,140	1,140	1,140	1,140	1,140	1,140	1,140
Amps @ 115V	4.2	4.7	4.7	5.8	5.8	5.8	9.4	11.6	11.6
DIMENSIONAL DATA - Inches (mm)									
"A" Overall Height to Top of Flue	33-3/4 (857)	33-3/4 (857)	33-3/4 (857)	33-3/4 (857)	33-3/4 (857)	33-3/4 (857)	34 (864)	34 (864)	34 (864)
"B" Jacket Width of Unit	20-3/4 (527)	20-3/4 (527)	20-3/4 (527)	32-3/4 (831)	32-3/4 (831)	32-3/4 (831)	50-3/4 (1289)	50-3/4 (1289)	50-3/4 (1289)
"C" Width to CL Flue	13-3/8 (340)	13-3/8 (340)	13-3/8 (340)	19-3/8 (492)	19-3/8 (492)	19-3/8 (492)	28-3/8 (721)	28-3/8 (721)	28-3/8 (721)
"D" Depth to Rear of Housing	11 (279)	11 (279)	11 (279)	11 (279)	11 (279)	11 (279)	12-1/4 (311)	12-1/4 (311)	12-1/4 (311)
"E" Hanging Distance Width	18-5/8 (473)	18-5/8 (473)	18-5/8 (473)	30-5/8 (778)	30-5/8 (778)	30-5/8 (778)	48-5/8 (1235)	48-5/8 (1235)	48-5/8 (1235)
"F" Discharge Opening Width	18-3/4 (476)	18-3/4 (476)	18-3/4 (476)	30-3/4 (781)	30-3/4 (781)	30-3/4 (781)	48-3/4 (1238)	48-3/4 (1238)	48-3/4 (1238)
"G" Depth to CL Flue	4-3/4 (121)	4-3/4 (121)	4-3/4 (121)	4-3/4 (121)	4-3/4 (121)	4-3/4 (121)	5-1/8 (130)	5-1/8 (130)	5-1/8 (130)
"L" Overall Unit Width	25-1/4 (641)	25-1/4 (641)	25-1/4 (641)	37-1/4 (946)	37-1/4 (946)	37-1/4 (946)	55-1/4 (1403)	55-1/4 (1403)	55-1/4 (1403)
Combustion Air Inlet Dia. (Qty) - in (mm)	5 (127)	5 (127)	5 (127)	5 (127)	5 (127)	5 (127)	5 (2) (127)	5 (2) (127)	5 (2) (127)
"M" Flue Size Diameter* - Inches (mm)	5 (127)	5 (127)	5 (127)	5 (127)	5 (127)	5 (127)	6 (152)	6 (152)	6 (152)
Gas Inlet, Natural Gas - Inches	1/2	1/2	1/2	1/2	1/2	3/4	3/4	3/4	3/4
Gas Inlet, LP Gas - Inches	1/2	1/2	1/2	1/2	1/2	3/4	3/4	3/4	3/4
Approximate Unit Weight - Lbs (kg)	135 (61)	147 (67)	157 (71)	194 (88)	204 (93)	214 (97)	311 (141)	325 (147)	339 (154)
Approximate Ship Weight - Lbs (kg)	175 (79)	187 (85)	197 (89)	244 (111)	254 (115)	264 (120)	371 (168)	385 (175)	399 (181)

† Ratings shown are for unit installations at elevations between 0 and 2,000 feet (0 to 610m). For unit installations in USA above 2,000 feet (610m), the unit input must be field derated 4% for each 1,000 feet (305m) above sea level; refer to local codes, or in absence of local codes, refer to the latest edition of the National Fuel Gas Code, ANSI Standard Z223.1 (NFPA No. 54).

For installations in Canada, any reference to deration at altitudes in excess of 2,000 feet (610m) are to be ignored. At altitudes of 2,000 feet to 4,500 feet (610 to 1372m), the unit must be field derated and be so marked in accordance with the ETL certification. See unit installation, operation and maintenance manual for deration information.

* Flue collar is factory supplied with unit; to be field installed per included instructions.

** LEGEND: SP = SHADED POLE PSC = PERMANENT SPLIT CAPACITOR ODP = OPEN DRIP PROOF

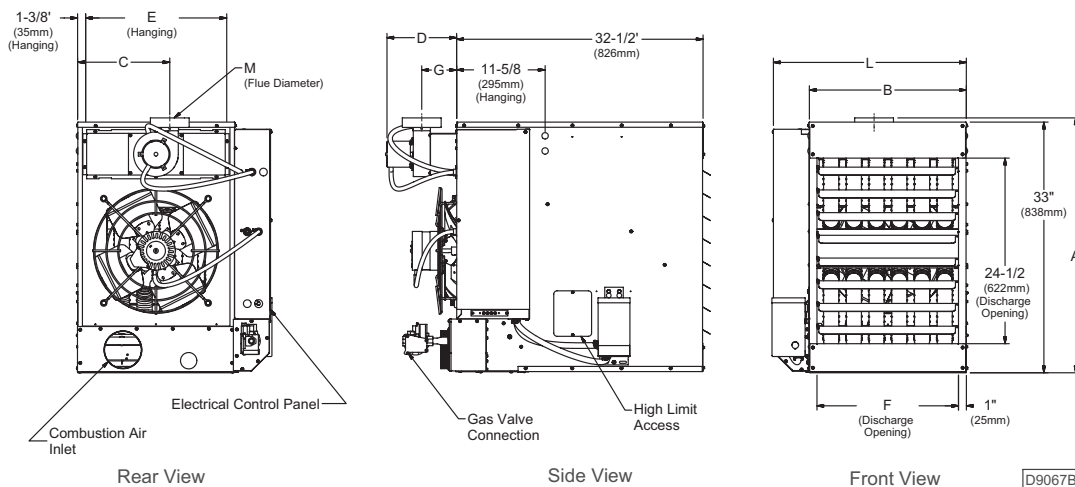

D9067B

SC Series — Separated Combustion Blower

Performance and Dimensional Data



UNIT CAPACITY (MBH)	100	125	150	175	200	250	300	350	400
PERFORMANCE DATA†									
Input - BTU/Hr (kW)	100,000 (29.3)	125,000 (36.6)	150,000 (44.0)	175,000 (51.3)	200,000 (58.6)	250,000 (73.3)	300,000 (87.9)	350,000 (102.6)	400,000 (117.2)
Output - BTU/Hr (kW)	83,000 (24.3)	103,750 (30.4)	124,500 (36.5)	145,250 (42.6)	166,000 (48.6)	207,500 (60.8)	246,000 (72.1)	290,500 (85.1)	332,000 (97.3)
Thermal Efficiency - %	83	83	83	83	83	83	82	83	83
Free Air Delivery - CFM (cu. m/s)	1,181 (0.557)	1,476 (0.697)	1,771 (0.836)	2,067 (0.976)	2,362 (1.115)	2,953 (1.394)	3,501 (1.652)	4,134 (1.951)	4,724 (2.230)
Air Temperature Rise - °F (°C)	65 (36)	65 (36)	65 (36)	65 (36)	65 (36)	65 (36)	65 (36)	65 (36)	65 (36)
Outlet Velocity - FPM (m/s)	370 (1.879)	463 (2.351)	555 (2.819)	395 (2.006)	451 (2.291)	564 (2.864)	422 (2.143)	498 (2.529)	570 (2.895)
Full Load Amps at 115V	7.3	9.4	8.19	14.2	14.2	15.6	15.6	20.8	20.8
Minimum Circuit Amps at 115V	8.6	11.2	11.2	17.1	17.1	18.9	18.9	25.4	25.4
MOTOR DATA:									
Motor HP (Qty)	1/4	1/2	1/2	3/4	3/4	1	1	1-1/2	1-1/2
Motor kW	0.19	0.37	0.37	0.56	0.56	0.75	0.75	1.11	1.11
Motor Type ODP**	SPH	SPH	SPH	SPH	SPH	Cap. Start	Cap. Start	Cap. Start	Cap. Start
RPM	1,725	1,725	1,725	1,725	1,725	1,725	1,725	1,725	1,725
Amps @ 115V	5.1	7.2	7.2	11.6	11.6	13.0	13.0	18.2	18.2
DIMENSIONAL DATA - Inches (mm)									
"A" Height to Top of Flue	33-3/4 (857)	33-3/4 (857)	33-3/4 (857)	33-3/4 (857)	33-3/4 (857)	33-3/4 (857)	34 (864)	34 (864)	34 (864)
"B" Jacket Width of Unit	20-3/4 (527)	20-3/4 (527)	20-3/4 (527)	32-3/4 (832)	32-3/4 (832)	32-3/4 (832)	50-3/4 (1289)	50-3/4 (1289)	50-3/4 (1289)
"C" Width to Centerline Flue	13-3/8 (340)	13-3/8 (340)	13-3/8 (340)	19-3/8 (492)	19-3/8 (492)	19-3/8 (492)	28-3/8 (721)	28-3/8 (721)	28-3/8 (721)
"D" Depth to Front Hanger	21 (533)	21 (533)	21 (533)	21 (533)	21 (533)	21 (533)	21 (533)	21 (533)	21 (533)
"E" Hanging Distance Width	18-5/8 (473)	18-5/8 (473)	18-5/8 (473)	30-5/8 (778)	30-5/8 (778)	30-5/8 (778)	48-5/8 (1235)	48-5/8 (1235)	48-5/8 (1235)
"F" Hanging Distance Depth	19 (483)	19-1/2 (495)	19-1/2 (495)	32-3/4 (832)	32-3/4 (832)	32-3/4 (832)	23-1/2 (597)	32-3/4 (832)	32-3/4 (832)
"G" Discharge Opening Width	18-3/4 (476)	18-3/4 (476)	18-3/4 (476)	30-3/4 (781)	30-3/4 (781)	30-3/4 (781)	48-3/4 (1238)	48-3/4 (1238)	48-3/4 (1238)
"H" Depth to Centerline Flue	4-3/4 (121)	4-3/4 (121)	4-3/4 (121)	4-3/4 (121)	4-3/4 (121)	4-3/4 (121)	5-1/8 (130)	5-1/8 (130)	5-1/8 (130)
"M" Overall Unit Width	25-1/4 (641)	25-1/4 (641)	25-1/4 (641)	37-1/4 (946)	37-1/4 (946)	37-1/4 (946)	55-1/4 (1403)	55-1/4 (1403)	55-1/4 (1403)
"P" Overall Unit Depth	49-3/4 (1264)	49-3/8 (1254)	49-3/8 (1254)	56-1/8 (1426)	56-1/8 (1426)	56-1/8 (1426)	53-3/8 (1356)	56-1/8 (1426)	56-1/8 (1426)
Combustion Air Inlet Dia. (Qty) - in (mm)	5 (127)	5 (127)	5 (127)	5 (127)	5 (127)	5 (127)	5 (2) (127)	5 (2) (127)	5 (2) (127)
*Flue Size Diameter - Inches (mm)	5 (127)	5 (127)	5 (127)	5 (127)	5 (127)	5 (127)	6 (152)	6 (152)	6 (152)
Gas Inlet, Natural Gas - Inches	1/2	1/2	1/2	1/2	1/2	3/4	3/4	3/4	3/4
Gas Inlet, LP Gas - Inches	1/2	1/2	1/2	1/2	1/2	3/4	3/4	3/4	3/4
Approximate Unit Weight - Lbs (kg)	173 (78)	177 (80)	204 (92)	248 (112)	267 (121)	292 (132)	374 (170)	394 (179)	433 (196)
Approximate Ship Weight - Lbs (kg)	258 (117)	263 (119)	291 (132)	384 (174)	403 (183)	428 (194)	524 (238)	551 (250)	599 (272)

† Ratings shown are for unit installations at elevations between 0 and 2,000 feet (0 to 610m). For unit installations in USA above 2,000 feet (610m), the unit input must be field derated 4% for each 1,000 feet (305m) above sea level; refer to local codes, or in absence of local codes, refer to the latest edition of the National Fuel Gas Code, ANSI Standard Z223.1 (NFPA No. 54).

For installations in Canada, any reference to deration at altitudes in excess of 2,000 feet (610m) are to be ignored. At altitudes of 2,000 feet to 4,500 feet (610 to 1372m), the unit must be field derated and be so marked in accordance with the ETL certification. See unit installation, operation and maintenance manual for deration information.

* Flue collar is factory supplied with unit; to be field installed per included instructions.

** LEGEND: SPH = SPLIT PHASE
CAP. START = CAPACITOR START
ODP = OPEN DRIP PROOF

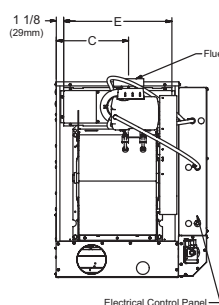

Rear View

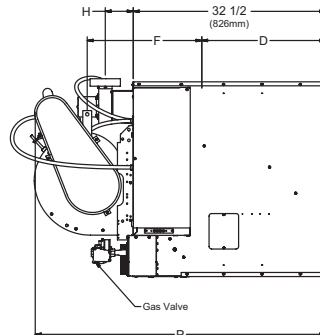

Side View

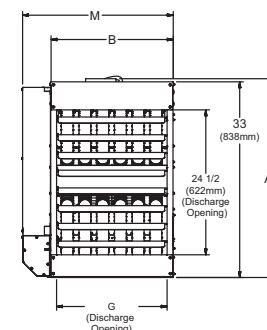

Front View

D9050B

SC Series — Separated Combustion Blower Performance Data

Unit	Temp.Rise °F (°C)	CFM (cu. m/s)	External Static Pressure Inches WC (kPa)									
			0.1" (0.02)		0.2" (0.05)		0.3" (0.07)		0.4" (0.10)		0.5" (0.12)	
			RPM	HP (kW)	RPM	HP (kW)	RPM	HP (kW)	RPM	HP (kW)	RPM	HP (kW)
SC100	50 (10)	1535 (0.724)	804	1/2 (0.37)	860	1/2 (0.37)	927	1/2 (0.37)	989	1/2 (0.37)	1045	1/2 (0.37)
	60 (15.5)	1279 (0.603)	649	1/4 (0.19)	760	1/4 (0.19)	821	1/4 (0.19)	890	1/4 (0.19)	963	1/4 (0.19)
	70 (21.1)	1096 (0.517)	633	1/4 (0.19)	700	1/4 (0.19)	779	1/4 (0.19)	858	1/4 (0.19)	920	1/4 (0.19)
	80 (26.6)	959 (0.452)	591	1/4 (0.19)	665	1/4 (0.19)	733	1/4 (0.19)	801	1/4 (0.19)	869	1/4 (0.19)
SC125	50 (10)	1919 (0.905)	703	1/2 (0.37)	758	1/2 (0.37)	810	1/2 (0.37)	863	1/2 (0.37)	918	1/2 (0.37)
	60 (15.5)	1599 (0.754)	608	1/2 (0.37)	685	1/2 (0.37)	741	1/2 (0.37)	790	1/2 (0.37)	843	1/2 (0.37)
	70 (21.1)	1371 (0.647)	558	1/2 (0.37)	626	1/2 (0.37)	694	1/2 (0.37)	755	1/2 (0.37)	798	1/2 (0.37)
	80 (26.6)	1199 (0.565)	580	1/2 (0.37)	597	1/2 (0.37)	649	1/2 (0.37)	720	1/2 (0.37)	779	1/2 (0.37)
SC150	50 (10)	2303 (1.087)	853	1/2 (0.37)	927	1/2 (0.37)	962	1/2 (0.37)	988	1/2 (0.37)	1040	1/2 (0.37)
	60 (15.5)	1919 (0.905)	755	1/2 (0.37)	810	1/2 (0.37)	845	1/2 (0.37)	894	1/2 (0.37)	939	1/2 (0.37)
	70 (21.1)	1645 (0.776)	649	1/2 (0.37)	726	1/2 (0.37)	790	1/2 (0.37)	836	1/2 (0.37)	876	1/2 (0.37)
	80 (26.6)	1439 (0.679)	616	1/2 (0.37)	670	1/2 (0.37)	720	1/2 (0.37)	785	1/2 (0.37)	840	1/2 (0.37)
SC175	50 (10)	2687 (1.26)	522	3/4 (0.56)	566	3/4 (0.56)	612	3/4 (0.56)	652	3/4 (0.56)	688	3/4 (0.56)
	60 (15.5)	2239 (1.05)	468	3/4 (0.56)	514	3/4 (0.56)	564	3/4 (0.56)	609	3/4 (0.56)	654	3/4 (0.56)
	70 (21.1)	1919 (0.905)	423	3/4 (0.56)	471	3/4 (0.56)	527	3/4 (0.56)	582	3/4 (0.56)	624	3/4 (0.56)
	80 (26.6)	1697 (0.8)	402	3/4 (0.56)	482	3/4 (0.56)	515	3/4 (0.56)	567	3/4 (0.56)	609	3/4 (0.56)
SC200	50 (10)	3071 (1.44)	592	3/4 (0.56)	627	3/4 (0.56)	670	3/4 (0.56)	702	3/4 (0.56)	748	3/4 (0.56)
	60 (15.5)	2559 (1.2)	526	3/4 (0.56)	561	3/4 (0.56)	597	3/4 (0.56)	647	3/4 (0.56)	688	3/4 (0.56)
	70 (21.1)	2193 (1.03)	468	3/4 (0.56)	519	3/4 (0.56)	556	3/4 (0.56)	612	3/4 (0.56)	653	3/4 (0.56)
	80 (26.6)	1919 (0.905)	432	3/4 (0.56)	481	3/4 (0.56)	537	3/4 (0.56)	593	3/4 (0.56)	638	3/4 (0.56)
SC250	50 (10)	3839 (1.81)	734	1 (0.75)	766	1 (0.75)	802	1 1/2 (1.11)	836	1 1/2 (1.11)	863	1 1/2 (1.11)
	60 (15.5)	3199 (1.51)	626	1 (0.75)	668	1 (0.75)	700	1 (0.75)	749	1 (0.75)	780	1 (0.75)
	70 (21.1)	2742 (1.29)	545	1 (0.75)	593	1 (0.75)	633	1 (0.75)	680	1 (0.75)	718	1 (0.75)
	80 (26.6)	2399 (1.13)	494	1 (0.75)	555	1 (0.75)	590	1 (0.75)	642	1 (0.75)	680	1 (0.75)
SC300	50 (10)	4551 (2.14)	734	1 (0.75)	766	1 (0.75)	802	1 1/2 (1.11)	836	1 1/2 (1.11)	863	1 1/2 (1.11)
	60 (15.5)	3792 (1.79)	626	1 (0.75)	668	1 (0.75)	700	1 (0.75)	749	1 (0.75)	780	1 (0.75)
	70 (21.1)	3259 (1.53)	545	1 (0.75)	593	1 (0.75)	633	1 (0.75)	680	1 (0.75)	718	1 (0.75)
	80 (26.6)	2844 (1.34)	494	1 (0.75)	555	1 (0.75)	590	1 (0.75)	642	1 (0.75)	680	1 (0.75)
SC350	50 (10)	5374 (2.54)	558	1 1/2 (1.11)	598	1 1/2 (1.11)	638	1 1/2 (1.11)	676	1 1/2 (1.11)	727	1 1/2 (1.11)
	60 (15.5)	4478 (2.11)	484	1 1/2 (1.11)	532	1 1/2 (1.11)	588	1 1/2 (1.11)	653	1 1/2 (1.11)	680	1 1/2 (1.11)
	70 (21.1)	3839 (1.81)	451	1 1/2 (1.11)	503	1 1/2 (1.11)	559	1 1/2 (1.11)	609	1 1/2 (1.11)	654	1 1/2 (1.11)
	80 (26.6)	3359 (1.59)	408	1 1/2 (1.11)	480	1 1/2 (1.11)	536	1 1/2 (1.11)	589	1 1/2 (1.11)	621	1 1/2 (1.11)
SC400	50 (10)	6142 (2.9)	647	1 1/2 (1.11)	659	1 1/2 (1.11)	670	1 1/2 (1.11)	713	1 1/2 (1.11)	751	2 (1.49)
	60 (15.5)	5118 (2.41)	553	1 1/2 (1.11)	570	1 1/2 (1.11)	618	1 1/2 (1.11)	653	1 1/2 (1.11)	697	1 1/2 (1.11)
	70 (21.1)	4387 (2.07)	483	1 1/2 (1.11)	523	1 1/2 (1.11)	568	1 1/2 (1.11)	615	1 1/2 (1.11)	660	1 1/2 (1.11)
	80 (26.6)	3839 (1.81)	437	1 1/2 (1.11)	490	1 1/2 (1.11)	547	1 1/2 (1.11)	589	1 1/2 (1.11)	655	1 1/2 (1.11)

TD Series — Duct Furnaces

Indoor Duct Furnace

DESCRIPTION

The TD Series duct furnace is the latest addition to the Sterling HVAC tubular product line. Designed for use with existing systems for any ducted air application. Sterling HVAC indoor tubular duct furnaces are available in 7 sizes (100 – 400 MBH). Sterling HVAC products are proudly manufactured in the USA.

Standard energy saving features like the direct spark ignition and power venting reduce standby losses and offer improved seasonal efficiencies. The TD Series is certified by ETL as providing 82% thermal (combustion) efficiency.

TUBULAR HEAT EXCHANGER

The Sterling HVAC tubular heat exchanger has been designed to provide maximum and uniform heat transfer. The low pressure drop associated with this design enables heated air to be evenly distributed to the conditioned space. This curved, non-welded serpentine design experiences less thermally induced stress making it highly durable for significantly longer service life. All standard Sterling HVAC tubular heat exchangers are constructed of heavy duty 20-gauge aluminized steel with an optional 409 stainless steel heat exchanger available for applications in mildly corrosive environments.

DIRECT SPARK IGNITION SYSTEM

Sterling HVAC TD units utilize a direct spark pilotless ignition of the burner, providing fast heat delivery. This highly reliable and efficient ignition system incorporates an integrated electronic control board to regulate the system sequence of operation, including an onboard LED indicator for simple troubleshooting.

VENTING

The Sterling HVAC TD Series is ETL certified in accordance with category III venting requirements. This certification allows units to be vented both vertically and horizontally using either single wall or double wall venting materials. This venting flexibility of the TD duct furnace makes installation easier and more cost effective by allowing the installer to utilize existing venting components. The TD duct furnace can be field converted to separated combustion using the “Air Inlet Kit” or the “Combustion Air Inlet Kit”. This is recommend for units to be installed in dusty, dirty or mildly corrosive environments or where high humidity or slightly negative pressures exist. All critical components including the burners, direct spark ignition, and controls are fully enclosed within the unit and protected from the elements ensuring clean and efficient combustion.

CONTROL ACCESSIBILITY

Designed with the service person in mind, every component of the Sterling HVAC TD Series is easily accessible. Ignition and fan controls are located in one centrally located control panel. The access panel provides control isolation as well as a pleasing exterior appearance.



TD-400



TD-100

TD Series — Duct Furnace

STANDARD FEATURES

- In-Shot Burner Design
- 20-Gauge Steel Jacket with Baked Enamel Finish
- Double Wall Construction
- 115/1/60 Supply Voltage
- Direct Spark Ignition
- Redundant Single-Stage Gas Valve
- 82% Thermal Efficiency
- 115/24 Volt Controls transformer
- Power Venter
- 20-Gauge Aluminized Steel Heat Exchanger
- Four Point Suspension
- For Natural or Propane Gas
- 10 Year Heat Exchanger, Flue Collector and Burner Warranty
- Easy Access Control Panel
- Left Hand Control Access – Field Convertible to Right Hand

OPTIONAL FEATURES

- 409 Stainless Steel Heat Exchanger and Flue Collector
- Supply Voltages (Field Mounted Transformer): 208 & 230/1/60 and 208, 230, 460, 575/3/60
- Two-Stage and Various Electronic Modulation Gas Controls
- High Pressure Regulator 1/2 - 35 PSI
- Single and Two-Stage Mercury Free Ductstats and Thermostats
- Locking Thermostat Cover
- Low Ambient Control
- Vent Caps
- 24V SPST Relay
- Stainless Steel Drip Pan
- Horizontal and Vertical Louvers
- Air Inlet Kit (For conversion to separated combustion and two roof or wall penetrations. Includes a vent cap for the combustion air inlet pipe)
- Combustion Air Inlet Kit (For conversion to separated combustion and a single roof or wall penetration)

Tubular Duct Furnace Unit Number Description

Digit	T	X	X	X	—	1	2	3	4	5	6	7	8	9	10	11	12	13	14	15	+
Item	Prefix					UT		CA			FT	FM	GT	AL	GC	SV	MT	MS	DL	AS	

(Internal use Only)

1, 2 - Unit Type [UT]

TD - Tubular Duct Furnace

3, 4, 5 - Capacity [CA]

- 100 - 100,000 BTU/HR
- 150 - 150,000 BTU/HR
- 200 - 200,000 BTU/HR
- 250 - 250,000 BTU/HR
- 300 - 300,000 BTU/HR
- 350 - 350,000 BTU/HR
- 400 - 400,000 BTU/HR

6 - Furnace Type [FT]

A - Left Side Access

Note: Field convertible to right side access; refer to unit installation instructions.

7 - Heat Exchanger (Furnace)

Material [FM]

1 - Aluminized Steel (Standard)

2 - 409 Stainless Steel

Note: Heat Exchanger Material [FM] selection includes flue collector material.

8 - Gas Type [GT]

N - Natural Gas

P - Propane Gas (LP)

9 - Altitude [AL]

S - 0-4,999 feet

T - 5,000-11,999 feet

Note: Installations over 2,000 feet require gas input deration in the field.

Refer to unit installation instructions.

10 - Direct Spark Gas Control [GC]

1 - Single Stage

2 - Two Stage

3 - Electronic Modulation w/Room Sensing

4 - Electronic Modulation w/Duct Sensing

5 - Electronic Modulation w/Duct Sensing & Room Override Stat

6 - Electronic Modulation w/External

4-20 mA Input

7 - Electronic Modulation w/External

0-10 VDC Input

11 - Supply Voltage [SV]

1 - 115/1/60

5 - 230/3/60

2 - 208/1/60

6 - 460/3/60

3 - 230/1/60

7 - 575/3/60

4 - 208/3/60

Z - Special

Note: Supply Voltages [SV] 2-7 include field mounted step down transformer.

12 - Motor Type [MT]

0 - None/Not Applicable

13 - Motor Sizes [MS]

0 - None/Not Applicable

14 - Design Level [DL]

A - First Design Level

15+ - Accessories [AS]

FACTORY INSTALLED

P4 - Terminal Block Wiring

P6 - Summer/Winter Switch

† FIELD INSTALLED (AS-____)

† All Field Installed Accessories are to be entered as a separate line item using the catalog number which utilizes "AS" as a prefix. i.e: G3 becomes AS-G3.

A7 - High Pressure Regulator:

A7-1/2-1 - Regulator for 0.5-10 PSI

A7-3/8-1 - Regulator for 10-20 PSI

A7-5/16-1 - Regulator for 20-35 PSI

F1 - One-Stage T675A Ductstat

F2 - Two-Stage T678A Ductstat

G1 - One-Stage T87K Mercury Free Thermostat w/Subbase Kit

G2 - One-Stage T87K Mercury Free Thermostat w/TG511A Guard Kit

G3 - One-Stage T834N Mercury Free Thermostat w/Fan Switch

G5 - Two-Stage TH5220D Mercury Free Thermostat w/Subbase

G6 - Locking Thermostat Cover

G9 - One-Stage T822K Mercury Free Thermostat

H5 - Low Ambient Control

M2-2 - Vent Cap (5 inch) (Unit Capacity 100-200)

M2-3 - Vent Cap (6 inch) (Unit Capacity 250-400)

P5 - 24V SPST Relay-Specify Purpose

S4 - Stainless Steel Drip Pan

X5 - Horizontal and Vertical Louver Kit

X8-H5 - Horizontal Combustion Air Inlet Kit, 5 inch (Unit Capacity 100-200)

X8-H6 - Horizontal Combustion Air Inlet Kit, 6 inch (Unit Capacity 250-400)

X8-V5 - Vertical Combustion Air Inlet Kit, 5 inch (Unit Capacity 100-200)

X8-V6 - Vertical Combustion Air Inlet Kit, 6 inch (Unit Capacity 250-400)

X9-DBL-5 - Air Inlet Kit, 5 inch (Unit Capacity 100-200)

X9-DBL-6 - Air Inlet Kit, 6 inch (Unit Capacity 250-400)

Note: X9 kits allow for conversion to separated combustion and include the M2 vent cap for the combustion air inlet pipe. X8 kits allow for conversion to separated combustion and venting concentrically through one roof or wall penetration.

TD Series — Duct Furnace

Dimensional Data

Tubular Duct Furnace Dimensions

Unit Capacity (MBH)	100	150	200	250	300	350	400
Dimensional Data - inches (mm)							
“A” Overall Unit Height	10.3 (262)	13.7 (348)	17 (432)	20.2 (513)	23.5 (597)	26.7 (678)	30 (762)
“B” Height to Centerline Flue	7.6 (193)	10.5 (267)	11.9 (302)	6.8 (173)	8.4 (213)	10 (254)	11.6 (295)
“C” Height to Gas Connection	2.5 (64)	3.7 (94)	5.3 (135)	7 (178)	7 (178)	8.7 (221)	10.3 (262)
“D” Opening Height, Front & Rear	8.5 (216)	11.7 (297)	15 (381)	18.2 (462)	21.5 (546)	24.7 (627)	28 (711)
“E” Overall Unit Depth	32.7 (831)	32.7 (831)	32.7 (831)	33.5 (851)	33.5 (851)	33.5 (851)	33.5 (851)
“F” Flue Size Diameter	5 (127)	5 (127)	5 (127)	6 (152)	6 (152)	6 (152)	6 (152)
“G” Air Inlet Size Diameter	5 (127)	5 (127)	5 (127)	6 (152)	6 (152)	6 (152)	6 (152)
Gas Inlet, Natural Gas - inch	1/2	1/2	1/2	3/4	3/4	3/4	3/4
Gas Inlet, LP Gas - inch	1/2	1/2	1/2	3/4	3/4	3/4	3/4
Approximate Unit Weight - lb (kg)	160 (73)	221 (100)	250 (113)	270 (122)	296 (134)	321 (146)	355 (161)
Approximate Ship Weight - lb (kg)	270 (122)	331 (150)	360 (163)	403 (183)	429 (195)	454 (206)	488 (221)

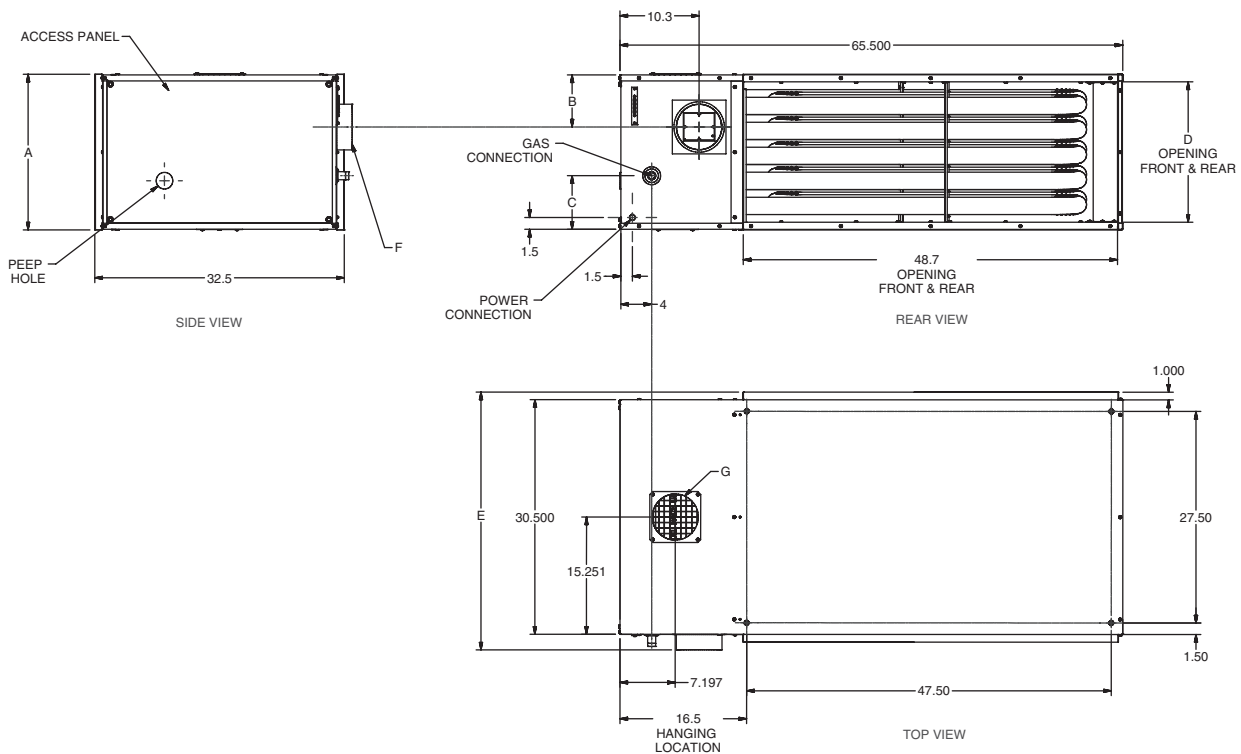

D9362

TD Series — Duct Furnace Performance Data

Tubular Duct Furnace Performance Data

UNIT CAPACITY (MBH)	100	150	200	250	300	350	400
Maximum Input - MBH (kW)	100 (29.3)	150 (43.9)	200 (58.6)	250 (73.2)	300 (87.8)	350 (102.5)	400 (117.1)
Minimum Input - MBH (kW)	50 (14.6)	75 (21.9)	100 (29.3)	125 (36.6)	150 (43.9)	175 (51.2)	200 (58.6)
Output - MBH (kW)	82 (24.0)	123 (36.0)	164 (48.0)	205 (60.0)	246 (72.0)	287 (84.1)	328 (96.1)
Full Load Amps at 115V	2.2	2.2	2.2	1.8	1.8	1.8	1.8
Minimum Circuit Amps at 115V	2.5	2.5	2.5	1.9	1.9	1.9	1.9
Minimum CFM (m ³ /s)	758 (0.357)	1137 (0.536)	1517 (0.715)	1896 (0.894)	2275 (1.074)	2654 (1.252)	3034 (1.431)
Temperature Rise - °F (°C)	100 (56)	100 (56)	100 (56)	100 (56)	100 (56)	100 (56)	100 (56)
Pressure Drop - in. WC (kPa)	0.07 (0.017)	0.03 (0.007)	0.04 (0.009)	0.08 (0.019)	0.03 (0.007)	0.07 (0.017)	0.08 (0.019)
Maximum CFM (m ³ /s)	2528 (1.193)	3792 (1.789)	5057 (2.386)	6321 (2.983)	7585 (3.579)	8849 (4.176)	10,114 (4.773)
Temperature Rise - °F (°C)	30 (17)	30 (17)	30 (17)	30 (17)	30 (17)	30 (17)	30 (17)
Pressure Drop - in. WC (kPa)	0.65 (0.16)	0.44 (0.11)	0.54 (0.13)	0.76 (0.19)	0.69 (0.16)	0.76 (0.19)	0.70 (0.17)

Ratings are shown for unit installations at elevations between 0 and 2,000 feet (610m). For unit installations in USA above 2,000 feet (610m), the unit input must be field derated 4% for each 1,000 feet (305m) above sea level; refer to local codes, or in absence of local codes, refer to the latest edition of the National Fuel Gas Code, ANSI Standard Z223.1 (NFPA 54). For installations in Canada, any references to deration at altitudes in excess of 2,000 feet (610m) are to be ignored. At altitudes of 2,000 to 4,500 feet (610 to 1372m), the unit must be field derated and be so marked in accordance with the ETL certification. See Installation Instructions for USA and Canadian field deration information.

Temperature Rise and Pressure Drop Graph

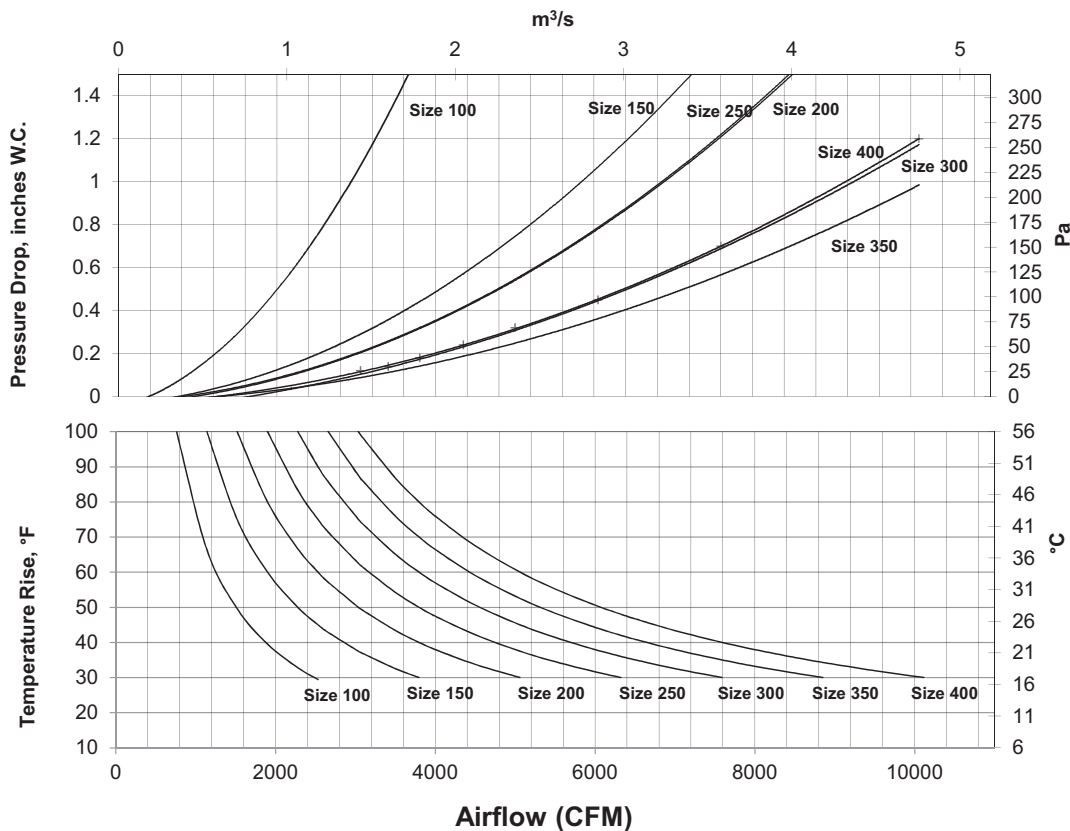

Duct Furnaces

- QVED SERIES
- QVES SERIES
- QVSD SERIES

Indoor Duct Furnace

Sterling HVAC's line of high efficient indoor duct furnaces are designed for ducted air applications. Indoor duct furnaces are designed for use with existing systems for heating, heating / cooling or make-up air systems. Sterling's indoor duct furnaces are available in 10 sizes (100 – 400 MBH) and equipped with electronic spark ignition (100% safety shutoff on LP models), 115 volt power, vent system pressure switch, high limit switch and 24 volt control transformer.

All duct furnaces are ETL certified for installation upstream or downstream from cooling coils (stainless steel heat exchangers are recommended).

Sterling HVAC's products are proudly manufactured in the USA.

HEAT EXCHANGERS

All heat exchangers feature 20-gauge tubes and 18-gauge headers and are available in 3 types of steel:

- Aluminized Steel (Standard)
- 409 Grade Stainless Steel (Optional)
- 321 Grade Stainless Steel (Optional)
- Stainless steel heat exchangers recommended for applications where entering air is below 40°F (4.4°C) and/or duct furnaces are located downstream from cooling coils.

APPLICATIONS

Sterling's duct furnaces are available in variable configurations to meet all application needs. QVED (bottom burner access) and QVES (side burner access) models offer integral power venting through a concentric vent for both outside combustion air and flue gas exhaust.

The QVSD (separated combustion) is designed to be installed in dusty, dirty or mildly corrosive environments, or where high humidity or slightly negative pressures exist. All critical components including the burners, pilot and flue systems are fully enclosed within the unit and protected from the elements insuring clean and efficient combustion. QVSD units are perfect for manufacturing and automotive facilities and greenhouse applications.



QVED/QVES Series

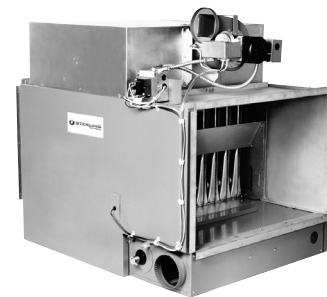

QVSD Series

QVED/QVES Series — Power Vented Duct Furnace

QVSD — Separated Combustion Duct Furnace

STANDARD FEATURES

- QVED – Bottom Access Panel
- QVES – Side Access Panel, Right Side
- QVSD – Separated Combustion
- 80% Thermal Efficiency
- Aluminized Steel Heat Exchanger – 20-gauge
- Aluminized Steel Burners with Stainless “Burner Shade Port Protector”
- For Natural and Propane Gases
- Aluminized Steel Flue Collector
- 115/1/60 Supply Voltage
- Spark Ignited Intermittent Pilot with Electronic Flame Supervision
- Power Venter
- Redundant Single Stage Combustion Gas Valve
- High Limit Switch
- Control Transformer, 115/24V
- Combustion Air Pressure Switch
- Adjustable Burner Air Shutters
- Four Point Suspension
- QVSD – Enclosed Combustion System
- 20-Gauge Steel Cabinet with Baked Enamel Finish
- QVSD – Combustion Air/Flue Connections (see Vent Caps; Two Required per Unit)

Unit Number Description

Digit	X	X	X	X	–	1	2	3	4	5	6	7	8	9	10	11	12	13	14	15	+	
Item	Prefix					UT	CA			FT	FM	GT	IC	AL	GC	SV	MT	MS	AS			

(Internal use Only)

Digit #1, 2 - Unit Type [UT]

- QVED (D2) - Power Vented Duct Furnace
- QVSD (D3) - Separated Combustion Duct Furnace
- QVES (D6) - Side Service Power Vented Duct Furnace

Digit #3, 4, 5 - Capacity [CA]

100 - 100,000 BTU/HR	225 - 225,000 BTU/HR
125 - 125,000 BTU/HR	250 - 250,000 BTU/HR
150 - 150,000 BTU/HR	300 - 300,000 BTU/HR
175 - 175,000 BTU/HR	350 - 350,000 BTU/HR
200 - 200,000 BTU/HR	400 - 400,000 BTU/HR

Digit #6 - Furnace Type [FT]

- A - Right Side Access (Standard)
- B - Left Side Access

Digit #7 - Heat Exchanger Construction Material [FM]

- 1 - Aluminized Steel
- 2 - 409 Stainless Steel
- 3 - 321 Stainless Steel

Digit #8 - Gas Type [GT]

- N - Natural Gas
- P - Propane Gas (LP)
- K - Natural Gas w/100% Shutoff

Digit #9 - Ignition Control [IC]

- 2 - Spark Ignition

Digit #10 - Altitude [AL]

- A - 0-1,999 feet
- B - 2,000-2,999 feet
- C - 3,000-3,999 feet
- D - 4,000-4,999 feet
- F - 5,000-5,999 feet
- G - 6,000-6,999 feet
- H - 7,000-7,999 feet
- J - 8,000-8,999 feet
- K - 9,000-9,999 feet
- L - 10,000-10,999 feet
- M - 11,000-11,999 feet
- N - Local Gas Supplier Derate
- P - Canadian High Altitude 2,000-4,500 feet

Digit #11 - Gas Control [GC]

- A - Single Stage
- B - Two Stage
- H - Electronic Modulation w/Room Sensing
- J - Electronic Modulation w/Duct Sensing
- K - Electronic Modulation w/Duct Sensing & Room Ovrd. Stat
- L - Electronic Modulation w/External 4-20 mA Input
- N - Electronic Modulation w/External 0-10 VDC Input

Digit #12 - Supply Voltage [SV]

- 1 - 115/1/60
 - 2 - 208/1/60
 - 3 - 230/1/60
 - 4 - 208/3/60
 - 5 - 230/3/60
 - 6 - 460/3/60
 - 7 - 575/3/60
 - Z - Special
- Note: Supply Voltages [SV] 2-7 include field mounted step down transformer.

Digit #13 - Motor Type [MT]

- 0 - None/Not Applicable

Digit #14 - Motor Sizes [MS]

- 0 - None/Not Applicable

Digit #15 - Accessories [AS]

FACTORY INSTALLED

- A8 - Input Derate
- K4 - Fan Time Delay
- K5 - Air Flow Prove Switch
- P4 - Terminal Block Wiring
- P6 - Summer/Winter Switch
- S1 - 409 Stainless Steel Burners
- S3 - 409 Stainless Steel Flue Collector

† FIELD INSTALLED (AS-____)

†Field Installed Accessories are not included in the Unit Number. All Field Installed Accessories are entered as a separate line item using the catalog number which utilizes “AS” as a prefix. i.e: A7 becomes AS-A7.

- A7 - High Pressure Regulator
 - A7 - 1/2-1 Regulator for 0.5-10 PSI
 - A7 - 3/8-1 Regulator for 10-20 PSI
 - A7 - 5/16-1 Regulator for 20-35 PSI
- F1 - 1-Stage T675A Ductstat
- F2 - 2-Stage T678A Ductstat
- G1 - 1-Stage T87K
- G2 - 1-Stage T87K
 - Mercury Free Thermostat w/Subbase Kit
- G2 - 1-Stage T87K
 - Mercury Free Thermostat w/TG511A Guard Kit
- G3 - 1-Stage T834N Mercury Free Thermostat w/Fan Switch
- G6 - Locking Thermostat Cover
- G9 - 1-Stage T822K
 - Mercury Free Thermostat
- H5 - Low Ambient Control
- M2-1 - Vent Caps (4 inch) (Unit Capacity 100-175)
- M2-2 - Vent Caps (5 inch) (Unit Capacity 200-250)
- M2-3 - Vent Caps (6 inch) (Unit Capacity 300-400)
- M3-1 - Adaptors (5-4 inch) (Unit Capacity 100-175)
- M4 - Vertical Combustion Air Inlet Kit
- M5 - Horizontal Combustion Air Inlet Kit
- P2 - Adjustable High Limit Switch
- P3 - Adjustable Fan Switch
- P5 - 24V SPST Relay-Specify Purpose
- Q7 - Horizontal/Vertical Louvers
- S4 - 409 Stainless Drip Pan (Only available on QVED and QVES)

QVSD Series — Separated Combustion Duct Furnace Performance and Dimensional Data

UNIT CAPACITY (MBH)	100	125	150	175	200	225	250	300	350	400
PERFORMANCE DATA†										
Input (Maximum) - BTU/Hr. (kW)	100,000 (29.3)	125,000 (36.6)	150,000 (44.0)	175,000 (51.3)	200,000 (58.6)	225,000 (65.9)	250,000 (73.3)	300,000 (87.9)	350,000 (102.6)	400,000 (117.2)
Input (Minimum) - BTU/Hr. (kW)	50,000 (14.6)	62,500 (18.3)	75,000 (22.0)	87,500 (25.6)	100,000 (29.3)	112,500 (33.0)	125,000 (36.6)	150,000 (44.0)	175,000 (51.3)	200,000 (58.6)
Output - BTU/Hr. (kW)	80,000 (23.4)	100,000 (29.3)	120,000 (35.1)	140,000 (41.0)	160,000 (46.9)	180,000 (52.7)	200,000 (58.6)	240,000 (70.3)	280,000 (82.0)	320,000 (93.7)
Thermal Efficiency - %	80	80	80	80	80	80	80	80	80	80
Free Air Delivery (Minimum) - CFM (cu. m/s)	822 (0.388)	1,028 (0.485)	1,233 (0.582)	1,439 (0.679)	1,645 (0.776)	1,850 (0.873)	2,056 (0.970)	2,467 (1.164)	2,878 (1.358)	3,289 (1.552)
Air Temperature Rise - °F (°C)	90 (50)	90 (50)	90 (50)	90 (50)	90 (50)	90 (50)	90 (50)	90 (50)	90 (50)	90 (50)
Pressure Drop - Inches WC (kPa)	0.10 (0.02)	0.09 (0.02)	0.09 (0.02)	0.09 (0.02)	0.09 (0.02)	0.09 (0.02)	0.09 (0.02)	0.10 (0.02)	0.10 (0.02)	0.10 (0.02)
Free Air Delivery (Maximum) - CFM (cu. m/s)	3,700 (1.746)	4,625 (2.183)	5,550 (2.620)	6,475 (3.056)	7,401 (3.493)	8,326 (3.930)	9,251 (4.366)	11,101 (5.240)	12,951 (6.113)	14,801 (6.986)
Air Temperature Rise - °F (°C)	20 (11)	20 (11)	20 (11)	20 (11)	20 (11)	20 (11)	20 (11)	20 (11)	20 (11)	20 (11)
Pressure Drop - Inches WC (kPa)	2.03 (0.51)	1.92 (0.48)	1.81 (0.45)	1.86 (0.46)	1.90 (0.47)	1.93 (0.48)	1.96 (0.49)	2.00 (0.50)	2.02 (0.50)	2.05 (0.51)
DIMENSIONAL DATA - Inches (mm)										
"A" Overall Unit Width	17-7/8 (454)	20-5/8 (524)	20-5/8 (524)	23-3/8 (594)	26-1/8 (664)	28-7/8 (733)	31-5/8 (803)	37-1/8 (943)	42-5/8 (1083)	48-1/8 (1222)
"B" Discharge Opening	15-1/2 (394)	18-1/4 (464)	18-1/4 (464)	21 (533)	23-3/4 (603)	26-1/2 (673)	29-1/4 (743)	34-3/4 (883)	40-1/4 (1022)	45-3/4 (1162)
"C" Hanging Distance Width	17-1/8 (435)	19-7/8 (505)	19-7/8 (505)	22-5/8 (575)	25-3/8 (645)	28-1/8 (714)	30-7/8 (784)	36-3/8 (924)	41-7/8 (1064)	47-3/8 (1203)
"D" Flue Opening Diameter*	4 (102)	4 (102)	4 (102)	4 (102)	5 (127)	5 (127)	5 (127)	6 (152)	6 (152)	6 (152)
Gas Inlet, Natural Gas - Inches	1/2	1/2	1/2	1/2	1/2	3/4	3/4	3/4	3/4	3/4
Gas Inlet, LP Gas - Inches	1/2	1/2	1/2	1/2	1/2	3/4	3/4	3/4	3/4	3/4
Approximate Ship Weight - lb (kg)	161 (73)	180 (82)	188 (85)	207 (93)	227 (103)	246 (116)	266 (121)	305 (138)	344 (156)	383 (174)

† Ratings shown are for unit installations at elevations between 0 and 2,000 feet (0 to 610m). For unit installations in U.S.A. above 2,000 feet (610m), the unit input must be derated 4% for each 1,000 feet (305m) above sea level; refer to local codes, or in absence of local codes, refer to the latest edition of the National Fuel Gas Code, ANSI Standard Z223.1 (NFPA No. 54).

For installations in Canada, any reference to deration at altitudes in excess of 2,000 feet (610m) are to be ignored. At altitudes of 2,000 feet to 4,500 feet (610 to 1372m), the unit must be derated and be so marked in accordance with the ETL certification. See unit installation, operation and maintenance manual for deration information.

* Flue collar is factory supplied with unit; to be field installed per included instructions.

QVSD Separated Combustion Duct Furnace — Bottom Service Access Only

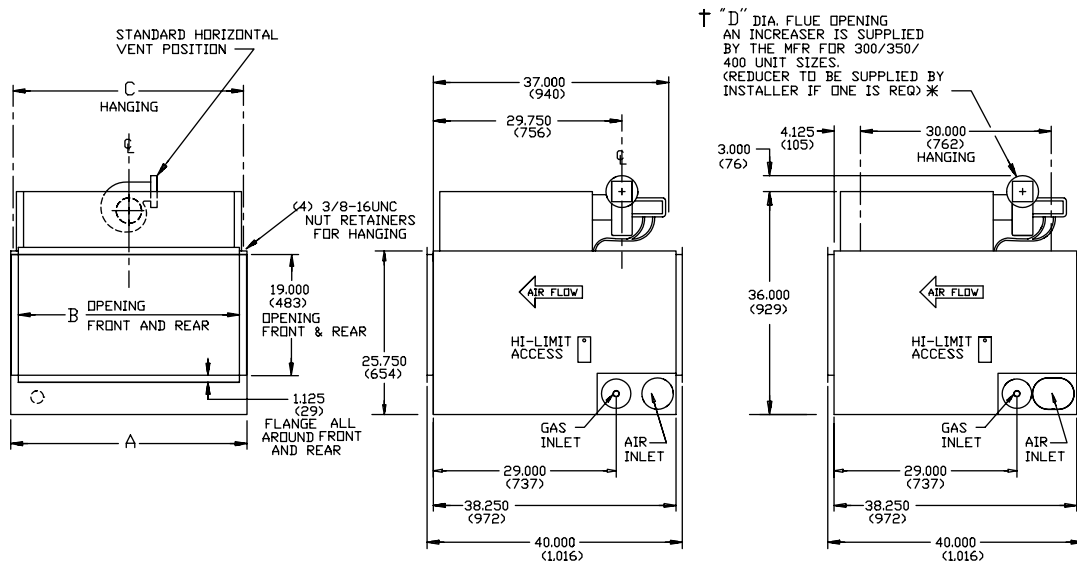

100/250 MBTU/HR UNIT SIZES

300/400 MBTU/HR UNIT SIZES
† OVAL CONNECTOR SHOWN ACCEPTS 6" DIA (152) PIPE

DIMENSIONS XXX STANDARD UNITS
DIMENSIONS IN PARENTHESIS (XXX) MILLIMETERS

D3862

QVED/QVES Series — Power Vented Duct Furnace Performance and Dimensional Data

UNIT CAPACITY (MBH)	100	125	150	175	200	225	250	300	350	400
PERFORMANCE DATA†										
Input (Maximum) - BTU/Hr. (kW)	100,000 (29.3)	125,000 (36.6)	150,000 (44.0)	175,000 (51.3)	200,000 (58.6)	225,000 (65.9)	250,000 (73.3)	300,000 (87.9)	350,000 (102.6)	400,000 (117.2)
Input (Minimum) - BTU/Hr. (kW)	50,000 (14.6)	62,500 (18.3)	75,000 (22.0)	87,500 (25.6)	100,000 (29.3)	112,500 (33.0)	125,000 (36.6)	150,000 (44.0)	175,000 (51.3)	200,000 (58.6)
Output - BTU/Hr. (kW)	80,000 (23.4)	100,000 (29.3)	120,000 (35.1)	140,000 (41.0)	160,000 (46.9)	180,000 (52.7)	200,000 (58.6)	240,000 (70.3)	280,000 (82.0)	320,000 (93.7)
Thermal Efficiency - %	80	80	80	80	80	80	80	80	80	80
Free Air Delivery (Minimum) - CFM (cu. m/s)	929 (0.438)	1,157 (0.546)	1,389 (0.656)	1,620 (0.765)	1,852 (0.874)	2,083 (0.983)	2,315 (1.093)	2,778 (1.311)	3,241 (1.530)	3,704 (1.748)
Air Temperature Rise - °F (°C)	80 (44)	80 (44)	80 (44)	80 (44)	80 (44)	80 (44)	80 (44)	80 (44)	80 (44)	80 (44)
Pressure Drop - Inches WC (kPa)	0.12 (0.03)	0.13 (0.03)	0.15 (0.04)	0.14 (0.03)	0.14 (0.03)	0.14 (0.03)	0.14 (0.03)	0.13 (0.03)	0.13 (0.03)	0.14 (0.03)
Free Air Delivery (Maximum) - CFM (cu. m/s)	2,469 (1.165)	3,086 (1.457)	3,704 (1.748)	4,321 (2.040)	4,938 (2.331)	5,556 (2.622)	6,173 (2.914)	7,407 (3.496)	8,642 (4.079)	9,877 (4.662)
Air Temperature Rise - °F (°C)	30 (17)	30 (17)	30 (17)	30 (17)	30 (17)	30 (17)	30 (17)	30 (17)	30 (17)	30 (17)
Pressure Drop - Inches WC (kPa)	0.90 (0.22)	0.80 (0.20)	0.75 (0.19)	0.75 (0.19)	0.75 (0.19)	0.75 (0.19)	0.80 (0.20)	0.90 (0.22)	0.90 (0.22)	0.90 (0.22)
DIMENSIONAL DATA - Inches (mm)										
"A" Overall Unit Width	17-7/8 (454)	20-5/8 (524)	20-5/8 (524)	23-3/8 (594)	26-1/8 (664)	28-7/8 (733)	31-5/8 (803)	37-1/8 (943)	42-5/8 (1083)	48-1/8 (1222)
"B" Discharge Opening	15-1/2 (394)	18-1/4 (464)	18-1/4 (464)	21 (533)	23-3/4 (603)	26-1/2 (673)	29-1/4 (743)	34-3/4 (883)	40-1/4 (1022)	45-3/4 (1162)
"C" Hanging Distance Width	17-1/8 (435)	19-7/8 (505)	19-7/8 (505)	22-5/8 (575)	25-3/8 (645)	28-1/8 (714)	30-7/8 (784)	36-3/8 (924)	41-7/8 (1064)	47-3/8 (1203)
"D" Flue Opening Diameter*	4 (102)	4 (102)	4 (102)	4 (102)	5 (127)	5 (127)	5 (127)	6 (152)	6 (152)	6 (152)
"F" Clearance for Burner Drawer Access (Side Access Type Only)	23-7/8 (606)	25-5/8 (651)	26-5/8 (676)	29-3/8 (746)	32-1/8 (816)	34-7/8 (886)	37-5/8 (956)	43-1/8 (1095)	48-5/8 (1235)	54-1/8 (1375)
Gas Inlet, Natural Gas - Inches	1/2	1/2	1/2	1/2	1/2	3/4	3/4	3/4	3/4	3/4
Gas Inlet, LP Gas - Inches	1/2	1/2	1/2	1/2	1/2	3/4	3/4	3/4	3/4	3/4
Approximate Ship Weight - lb (kg)	173 (78)	186 (84)	197 (89)	216 (98)	232 (105)	254 (115)	263 (119)	312 (142)	389 (176)	403 (183)

† Ratings shown are for unit installations at elevations between 0 and 2,000 feet (0 to 610m). For unit installations in U.S.A. above 2,000 feet (610m), the unit input must be derated 4% for each 1,000 feet (305m) above sea level; refer to local codes, or in absence of local codes, refer to the latest edition of the National Fuel Gas Code, ANSI Standard Z223.1 (NFPA No. 54).

For installations in Canada, any reference to deration at altitudes in excess of 2,000 feet (610m) are to be ignored. At altitudes of 2,000 feet to 4,500 feet (610 to 1372m), the unit must be derated and be so marked in accordance with the ETL certification. See unit installation, operation and maintenance manual for deration information.

* Flue collar is factory supplied with unit; to be field installed per included instructions.

Temperature Rise and Pressure Drop Graph

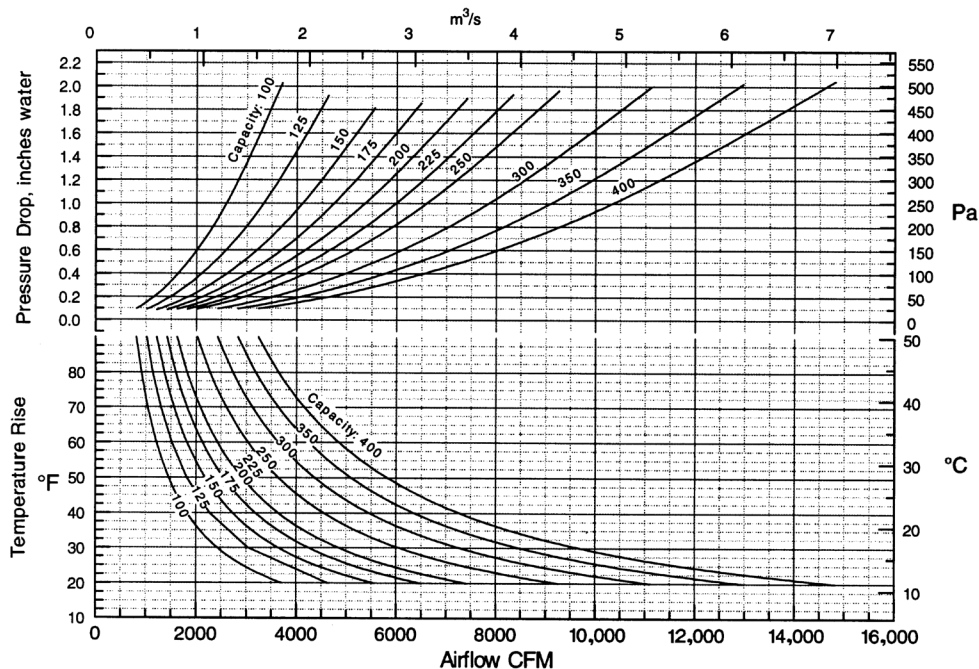

QVED/QVED Series — Power Vented Duct Furnace Dimensional Data

QVED Power Vented Duct Furnace — Bottom Service Access

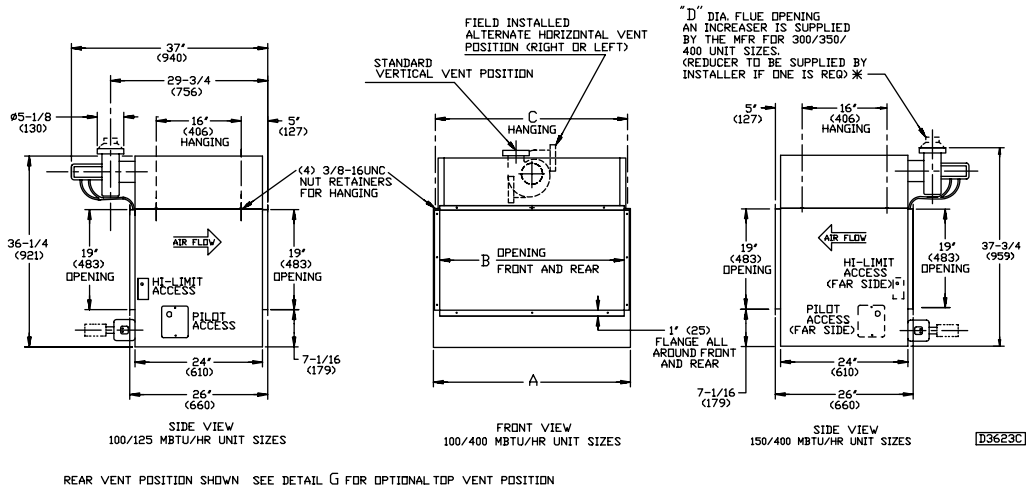

QVES Power Vented Duct Furnace — Side Service Access

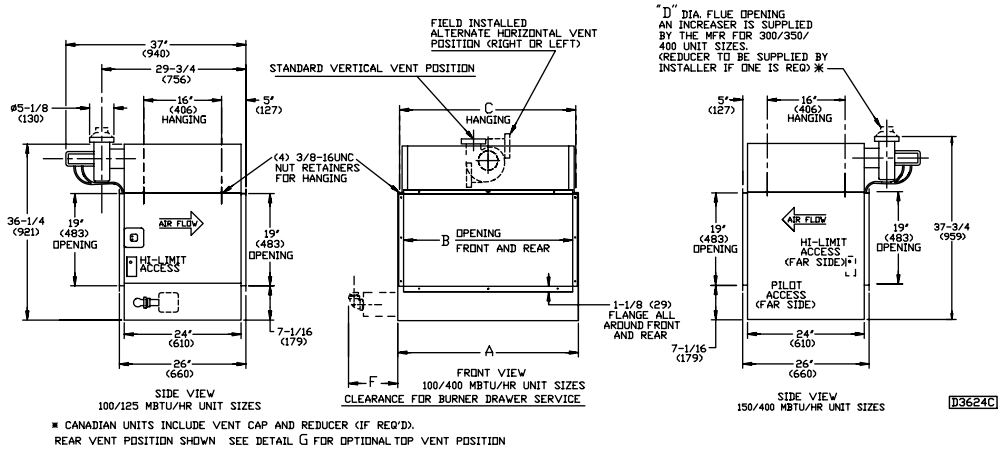

Detail G — Optional Top Vent Position

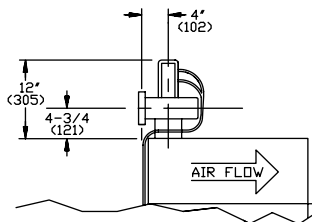

DETAIL G

POSITIONS - FRONT - REAR - RIGHT - LEFT

DIMENSIONS XX' STANDARD UNITS
DIMENSIONS IN PARENTHESIS (XX) MILLIMETERS

D3616A

CAB Series — Cabinet Blower

STANDARD FEATURES

- Sterling Cabinet Blowers have been especially designed for use with Sterling Duct Furnaces.
- Duct Flange at rear to facilitate attaching Ductwork.
- Side panels removable for inspection, servicing and motor maintenance.
- Specify Unit Number of both Cabinet Blower and Duct Furnace on Order, thus CAB2 150 indicates CAB2 Blower with 150,000 BTU Duct Furnace.
- Four sizes provide CFM capacities ranging from 1,250 to 8,000 CFM (0.59 to 3.78 m³/s).
- Sheet metal duct pieces for connecting Cabinet Blower to Duct Furnace are furnished only with Sterling Cabinet Blower-Duct Furnace combinations.
- Cabinet finished in baked enamel.

Unit Number Description

Digit	C	X	X	X	—	1	2	3	4	5	6	7	8	9	10	11	+
Item	Prefix					UT				CA			SV	MT	MS	AS	
	(Internal use Only)																

1, 2, 3, 4 - Unit Type [UT]

CAB1 - Cabinet Blower Size 1
CAB2 - Cabinet Blower Size 2
CAB3 - Cabinet Blower Size 3
CAB4 - Cabinet Blower Size 4

5, 6, 7 - Furnace Capacity [CA]*

100 - 100,000 BTU/HR
125 - 125,000 BTU/HR
150 - 150,000 BTU/HR
175 - 175,000 BTU/HR
200 - 200,000 BTU/HR
225 - 225,000 BTU/HR
250 - 250,000 BTU/HR
300 - 300,000 BTU/HR
350 - 350,000 BTU/HR
400 - 400,000 BTU/HR
000 - No Transition Required

* Indicates transition duct size needed for corresponding QVED or QVES Duct Furnace. Refer to "Compatible Duct Furnace Capacity" indicated in the table on page 22.

8 - Supply Voltage [SV]

1 - 115/1/60 **5** - 230/3/60
2 - 208/1/60 **6** - 460/3/60
3 - 230/1/60 **7** - 575/3/60
4 - 208/3/60 **Z** - Other

9 - Motor Type [MT]

1 - Open Drip Proof
2 - Totally Enclosed
3 - Premium Efficiency, Open Drip Proof
4 - Premium Efficiency, Totally Enclosed

10 - Blower Motor Sizes [MS]

B - 1/3 HP w /Contactor **K** - 1/3 HP
C - 1/2 HP w/Contactor **L** - 1/2 HP
D - 3/4 HP w/Contactor **M** - 3/4 HP
F - 1 HP w/Contactor **N** - 1 HP
G - 1-1/2 HP w/Contactor
H - 2 HP w/Contactor
J - 3 HP w/Contactor

P - 1/2 HP w/Magnetic Starter
R - 3/4 HP w/Magnetic Starter
S - 1 HP w/Magnetic Starter
T - 1-1/2 HP w/Magnetic Starter
U - 2 HP w/Magnetic Starter
W - 3 HP w/Magnetic Starter
Y - 1/3 HP w/Magnetic Starter

11 - Accessories [AS]

All Field Installed Accessories are to be entered as a separate line item using the catalog number which utilizes "AS" as a prefix. i.e: F1 becomes AS-F1.

FACTORY INSTALLED

B1 - 1 inch Washable Filters
B6 - 1 inch Throwaway Filters

K4 - Fan Time Delay

P4 - Terminal Block Wiring

Y5 - Cabinet Insulation
Y6 - Transition Insulation

FIELD INSTALLED (AS-____)

F1 - 1-Stage T675A Ductstat
F2 - 2-Stage T678A Ductstat

G1 - 1-Stage T87K Mercury Free Thermostat w/Subbase
G2 - 1-Stage T87K Mercury Free Thermostat w/TG511A Guard Kit
G3 - 1-Stage T834N Mercury Free Thermostat/Fan Switch
G5 - 2-Stage TH5220D Mercury Free Thermostat w/Subbase
G6 - Locking Thermostat Cover
G9 - 1-Stage T822K Mercury Free Thermostat

Motor Data – Amps

	1-(115/1/60)				2 - (208/1/60)				3 - (230/1/60)				4 - (208/3/60)			
	1 ODP	2 TE	3 PEODP	4 PETE	1 ODP	2 TE	3 PEODP	4 PETE	1 ODP	2 TE	3 PEODP	4 PETE	1 ODP	2 TE	3 PEODP	4 PETE
1/3 HP	6.1	6.0	4.4	3.2	3.4				3.1	3.0	1.6	1.6	1.5	1.6		
1/2 HP	7.2	8.6	4.6	4.6	3.7		2.8		3.8	4.3	2.3	2.3	2.3	2.0	1.8	1.7
3/4 HP	11.6	11.0	6.5	6.3	5.2	5.4	3.4		5.0	5.5	3.3	3.2	3.0	3.2	2.5	
1 HP	13.0	13.4	8.6	8.5	6.6	6.8			6.5	6.7	4.3	4.3	3.4	3.7	3.1	3.1
1-1/2 HP	18.2	18.0	12.5	12.6	9.1	8.4			9.1	8.0	6.3	6.3	5.1	5.0	4.5	4.5
2 HP	21.0			17.6	11.3				10.5			8.8	6.2		5.8	6.0
3 HP	33.5	28.0			17.4	14.6			16.8	14.0		11.8	9.2		8.5	9.0
	5 - (230/3/60)				6 - (460/3/60)				7 - (575/3/60)							
	1 ODP	2 TE	3 PEODP	4 PETE	1 ODP	2 TE	3 PEODP	4 PETE	1 ODP	2 TE	3 PEODP	4 PETE				
1/3 HP	1.6	1.9			0.8	0.8										
1/2 HP	2.2	2.5	1.8	2.0	1.1	1.0	0.9	1.0	0.8	0.8						
3/4 HP	3.4	3.0	2.4	2.8	1.7	1.5	1.2	1.4	1.1	1.1						
1 HP	3.4	3.4	3.0	3.1	1.7	1.7	1.5	1.5	1.3	1.7	1.2	1.2				
1-1/2 HP	5.2	4.6	4.4	4.4	2.6	2.3	2.2	2.2	1.7		1.8	1.8				
2 HP	6.0		5.8	5.8	3.0		2.9	2.9			2.3	2.4				
3 HP	8.6		8.4	8.4	4.3		4.2	4.2			3.4	3.2				

CAB Series — Cabinet Blower

Dimensional Data

MODEL NO. *	A	B	C	D	E	F	G	APPR. SHIP WT.		
	inch (mm)	inch (mm)	inch (mm)	inch (mm)	inch (mm)	inch (mm)	inch (mm)	FILTER DATA SIZE **	FILTER REQ'D.	LESS MOTOR LB (KG)
CAB-1/100	65-1/2 (1664)	26 (660)	10 (254)	18 (457)	21-1/4 (540)	15-3/4 (400)	15-5/8 (397)	25 X 25 X 1	1	135 (61)
CAB-1/125	65-1/2 (1664)	26 (660)	10 (254)	18 (457)	21-1/4 (540)	15-3/4 (400)	18-3/8 (467)	25 X 25 X 1	1	135 (61)
CAB-2/150	65-1/2 (1664)	26 (660)	10 (254)	18 (457)	21-1/4 (540)	15-3/4 (400)	18-3/8 (467)	25 X 25 X 1	1	155 (70)
CAB-2/175	65-1/2 (1664)	26 (660)	10 (254)	18 (457)	21-1/4 (540)	15-3/4 (400)	21-1/8 (537)	25 X 25 X 1	1	155 (70)
CAB-3/200	65-1/2 (1664)	40-1/2 (1029)	10 (254)	18 (457)	35-3/4 (908)	30-3/8 (772)	23-7/8 (606)	25 X 20 X 1	2	200 (91)
CAB-3/225	65-1/2 (1664)	40-1/2 (1029)	10 (254)	18 (457)	35-3/4 (908)	30-3/8 (772)	26-5/8 (676)	25 X 20 X 1	2	200 (91)
CAB-3/250	65-1/2 (1664)	40-1/2 (1029)	10 (254)	18 (457)	35-3/4 (908)	30-3/8 (772)	29-3/8 (746)	25 X 20 X 1	2	200 (91)
CAB-4/300	65-1/2 (1664)	60-1/2 (1537)	10 (254)	18 (457)	55-3/4 (1416)	50-3/8 (1280)	34-7/8 (886)	25 X 20 X 1	3	296 (134)
CAB-4/350	69-1/2 (1765)	60-1/2 (1537)	14 (356)	22 (559)	55-3/4 (1416)	50-3/8 (1280)	40-3/8 (1026)	25 X 20 X 1	3	296 (134)
CAB-4/400	69-1/2 (1765)	60-1/2 (1537)	14 (356)	22 (559)	55-3/4 (1416)	50-3/8 (1280)	45-7/8 (1165)	25 X 20 X 1	3	296 (134)

*Never use a single cabinet blower to handle more than one duct furnace. CAB-4 has two blowers driven by one motor.

**Standard filters are 1 inch thick throw away type. Side panels removable for inspection, servicing and motor maintenance. Cabinet painted gray enamel.

Sterling reserves the right to change specifications without incurring obligations.

Cabinet blower units are not certified by ETL.

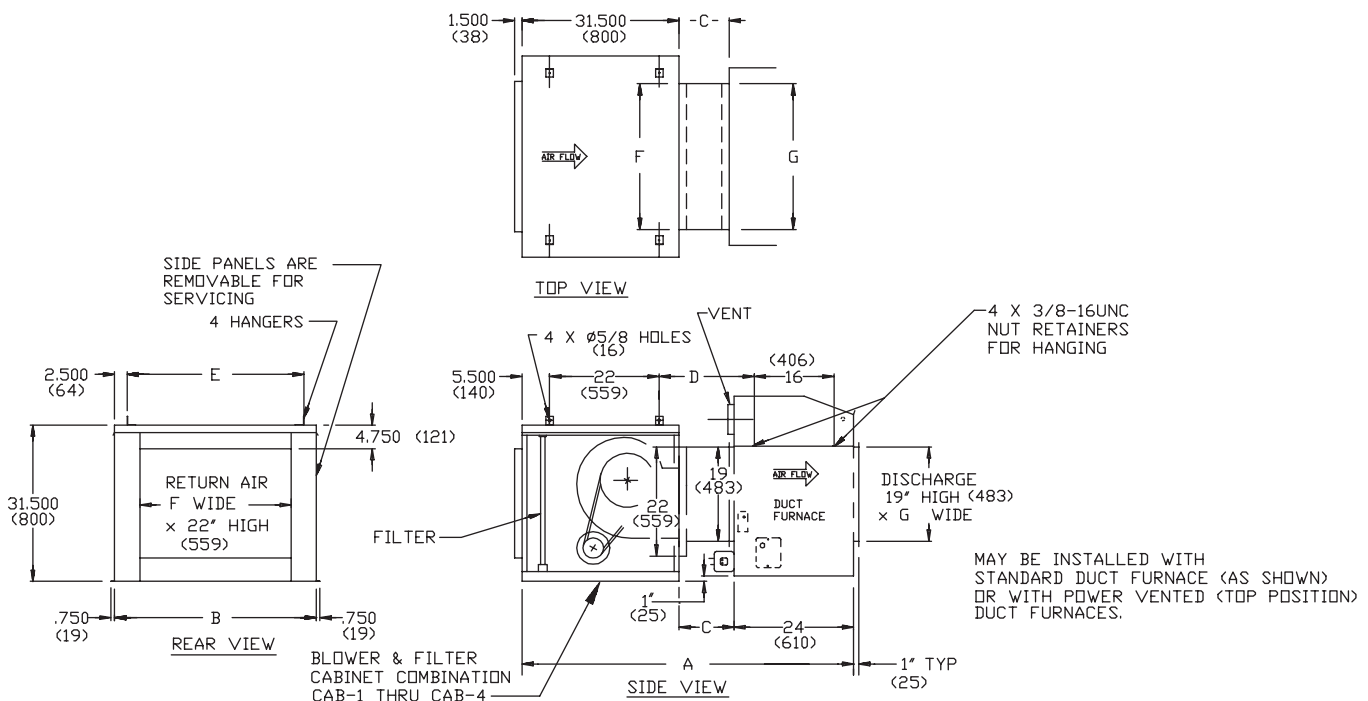

D3627
T3618

DIMENSIONS .XXX STANDARD UNITS
DIMENSIONS IN PARENTHESIS (XX) MILLIMETERS

CAB Series – Cabinet Blower Performance Data

Total Static Pressure *

inch of WC (kPa)

MODEL	0.2 (0.05)		0.3 (0.07)		0.4 (0.10)		0.5 (0.12)		0.6 (0.15)		0.7 (0.17)		0.8 (0.20)		0.9 (0.22)		DUCT FURNACE SECTIONS PRESSURE DROP				
	CFM (cu. m/s)	RPM	HP (kW)	RPM	HP (kW)	RPM	HP (kW)	RPM	HP (kW)	RPM	HP (kW)	RPM	HP (kW)	RPM	HP (kW)	RPM	HP (kW)	SIZE (kPa)	inch WC (kPa)	SIZE (kPa)	inch WC (kPa)
CAB 1 10" BLOWER	1,250 (0.590)	525	1/3 (0.25)	650	1/3 (0.25)	680	1/3 (0.25)	760	1/3 (0.25)	780	1/3 (0.25)	840	1/3 (0.25)	100 (0.04)	0.16
	1,250 (0.590)	525	1/3 (0.25)	650	1/3 (0.25)	680	1/3 (0.25)	760	1/3 (0.25)	780	1/3 (0.25)	840	1/3 (0.25)	125 (0.02)	0.10
	1,500 (0.708)	600	1/3 (0.25)	680	1/3 (0.25)	715	1/3 (0.25)	790	1/3 (0.25)	810	1/2 (0.37)	860	1/2 (0.37)	895 (0.37)	1/2 (0.37)	970 (0.37)	1/2 (0.37)	125 (0.04)	0.15
	1,750 (0.826)	650	1/3 (0.25)	710	1/3 (0.25)	750	1/2 (0.37)	805	1/2 (0.37)	850	1/2 (0.37)	890	1/2 (0.37)	940 (0.56)	3/4 (0.56)	990 (0.56)	3/4 (0.56)	125 (0.04)	0.18
	2,000 (0.944)	700	1/2 (0.37)	760	1/2 (0.37)	800	1/2 (0.37)	850	1/2 (0.37)	890	1/2 (0.37)	925	3/4 (0.56)	980 (0.56)	3/4 (0.56)	1,010 (0.56)	3/4 (0.56)	125 (0.06)	0.24
	1,500 (0.708)	425	1/3 (0.25)	500	1/3 (0.25)	550	1/3 (0.25)	630	1/3 (0.25)	150 (0.02)	0.09	175 (0.02)	0.07
	1,750 (0.826)	450	1/3 (0.25)	515	1/3 (0.25)	560	1/3 (0.25)	635	1/2 (0.37)	680	1/2 (0.37)	725	1/2 (0.37)	150 (0.04)	0.15	175 (0.03)	0.11
CAB 2 BLOWER	2,000 (0.944)	475	1/3 (0.25)	530	1/3 (0.25)	590	1/2 (0.37)	640	1/2 (0.37)	690	1/2 (0.37)	740	1/2 (0.37)	785 (0.37)	1/2 (0.37)	810 (0.56)	3/4 (0.56)	150 (0.05)	0.20	175 (0.03)	0.14
	2,250 (1.062)	515	1/2 (0.37)	560	1/2 (0.37)	610	1/2 (0.37)	650	1/2 (0.37)	700	3/4 (0.56)	750	3/4 (0.56)	790 (0.56)	3/4 (0.56)	815 (0.56)	3/4 (0.56)	175 (0.04)	0.18
	2,500 (1.180)	540	1/2 (0.37)	590	1/2 (0.37)	625	1/2 (0.37)	670	1/2 (0.37)	710	3/4 (0.56)	760	3/4 (0.56)	795 (0.56)	3/4 (0.56)	820 (0.56)	3/4 (0.56)	175 (0.05)	0.22
	2,750 (1.298)	575	1/2 (0.37)	615	1/2 (0.37)	650	3/4 (0.56)	690	3/4 (0.56)	730	3/4 (0.56)	780	3/4 (0.56)	800 (0.56)	3/4 (0.56)	830 (0.75)	1 (0.75)	175 (0.07)	0.27
	1,750 (0.826)	450	1/3 (0.25)	510	1/3 (0.25)	560	1/3 (0.25)	630	1/3 (0.25)	675	1/2 (0.37)	720	1/2 (0.37)	200 (0.02)	0.09
	2,000 (0.944)	475	1/3 (0.25)	525	1/3 (0.25)	590	1/2 (0.37)	635	1/2 (0.37)	680	1/2 (0.37)	735	1/2 (0.37)	785 (0.37)	1/2 (0.37)	810 (0.56)	3/4 (0.56)	200 (0.03)	0.11	225 (0.03)	0.09
	2,250 (1.062)	500	1/2 (0.37)	550	1/2 (0.37)	600	1/2 (0.37)	645	1/2 (0.37)	685	1/2 (0.37)	740	3/4 (0.56)	785 (0.56)	3/4 (0.56)	810 (0.56)	3/4 (0.56)	200 (0.03)	0.14	225 (0.03)	0.11
CAB 3 12" BLOWER	2,500 (1.180)	525	1/2 (0.37)	580	1/2 (0.37)	615	1/2 (0.37)	665	1/2 (0.37)	700	3/4 (0.56)	750	3/4 (0.56)	790 (0.56)	3/4 (0.56)	815 (0.56)	3/4 (0.56)	200 (0.04)	0.17	225 (0.03)	0.13
	2,750 (1.298)	560	1/2 (0.37)	605	1/2 (0.37)	640	3/4 (0.56)	685	3/4 (0.56)	715	3/4 (0.56)	775	3/4 (0.56)	805 (0.56)	3/4 (0.56)	825 (0.75)	1 (0.75)	200 (0.05)	0.20	225 (0.03)	0.14
	3,000 (1.416)	610	1/2 (0.37)	640	3/4 (0.56)	660	3/4 (0.56)	710	3/4 (0.56)	750	1 (0.75)	790	1 (0.75)	815 (0.75)	1 (0.75)	845 (0.75)	1 (0.75)	200 (0.05)	0.22	225 (0.04)	0.175
	2,250 (1.062)	500	1/2 (0.37)	550	1/2 (0.37)	590	1/2 (0.37)	645	1/2 (0.37)	675	1/2 (0.37)	735	1/2 (0.37)	780 (0.56)	3/4 (0.56)	805 (0.56)	3/4 (0.56)	250 (0.02)	0.09
	2,500 (1.180)	520	1/2 (0.37)	580	1/2 (0.37)	610	1/2 (0.37)	665	1/2 (0.37)	700	3/4 (0.56)	745	3/4 (0.56)	800 (0.56)	3/4 (0.56)	810 (0.56)	3/4 (0.56)	250 (0.03)	0.11
	2,750 (1.298)	550	1/2 (0.37)	605	1/2 (0.37)	640	3/4 (0.56)	680	3/4 (0.56)	710	3/4 (0.56)	770	3/4 (0.56)	810 (0.56)	3/4 (0.56)	820 (0.56)	3/4 (0.56)	250 (0.03)	0.12
	3,000 (1.416)	600	3/4 (0.56)	640	3/4 (0.56)	670	3/4 (0.56)	705	3/4 (0.56)	730	3/4 (0.56)	785	1 (0.75)	820 (0.75)	1 (0.75)	840 (0.75)	1 (0.75)	250 (0.03)	0.14
	3,250 (1.534)	630	3/4 (0.56)	675	3/4 (0.56)	700	1 (0.75)	735	1 (0.75)	750	1 (0.75)	790	1 (0.75)	830 (0.75)	1 (0.75)	860 (0.75)	1 (0.75)	250 (0.04)	0.16
	3,500 (1.652)	675	3/4 (0.56)	700	1 (0.75)	725	1 (0.75)	775	1 (0.75)	800	1 (0.75)	840	1-1/2 (1.12)	875 (1.12)	1-1/2 (1.12)	890 (1.12)	1-1/2 (1.12)	250 (0.05)	0.20
	2,750 (1.298)	400	3/4 (0.56)	450	3/4 (0.56)	510	3/4 (0.56)	300 (0.02)	0.09
	3,000 (1.416)	425	3/4 (0.56)	475	3/4 (0.56)	550	3/4 (0.56)	600	3/4 (0.56)	650	3/4 (0.56)	300 (0.02)	0.10
	3,500 (1.652)	430	3/4 (0.56)	480	3/4 (0.56)	560	3/4 (0.56)	610	3/4 (0.56)	660	3/4 (0.56)	700	1 (0.75)	730 (0.75)	1 (0.75)	300 (0.03)	0.14	350 (0.03)	0.1
	4,000 (1.888)	450	3/4 (0.56)	500	3/4 (0.56)	565	3/4 (0.56)	615	3/4 (0.56)	670	1 (0.75)	710	1 (0.75)	740 (0.75)	1 (0.75)	790 (0.75)	1 (0.75)	300 (0.04)	0.18	350 (0.03)	0.13
4,500 (2.124)	475	3/4 (0.56)	525	3/4 (0.56)	575	3/4 (0.56)	620	1 (0.75)	680	1 (0.75)	715	1 (0.75)	750 (0.75)	1 (0.75)	800 (1.12)	1-1/2 (1.12)	350 (0.04)	0.16	400 (0.03)	0.14	
5,000 (2.360)	500	3/4 (0.56)	540	3/4 (0.56)	600	1 (0.75)	630	1 (0.75)	690	1 (0.75)	720 (1.12)	1-1/2 (1.12)	760 (1.12)	1-1/2 (1.12)	810 (1.12)	1-1/2 (1.12)	350 (0.05)	0.20	400 (0.04)	0.17	
5,500 (2.596)	530	1 (0.75)	575	1 (0.75)	615	1 (0.75)	650	1-1/2 (1.12)	700	1-1/2 (1.12)	700	1-1/2 (1.12)	730 (1.12)	1-1/2 (1.12)	820 (1.12)	1-1/2 (1.12)	350 (0.06)	0.23	400 (0.05)	0.2	
6,000 (2.832)	575	1-1/2 (1.12)	615	1-1/2 (1.12)	660	1-1/2 (1.12)	690	1-1/2 (1.12)	715	1-1/2 (1.12)	760	2 (1.49)	800 (1.49)	2 (1.49)	830 (1.49)	2 (1.49)	350 (0.06)	0.26	400 (0.06)	0.23	
6,500 (3.068)	610	1-1/2 (1.12)	660	2 (1.49)	710	2 (1.49)	750	2 (1.49)	800	2 (1.49)	840	2 (2.24)	890 (2.24)	3 (2.24)	930 (2.24)	3 (2.24)	350 (0.07)	0.30	400 (0.06)	0.26	
7,000 (3.304)	720	1-1/2 (1.12)	790	2 (1.49)	830	2 (1.49)	860	2 (1.49)	910	3 (2.24)	940	3 (2.24)	960	3 (2.24)	NA	NA	400 (0.07)	0.28	
7,500 (3.540)	800	2 (1.49)	860	2 (1.49)	900	3 (2.24)	930	3 (2.24)	960	3 (2.24)	NA	NA	NA	NA	NA	NA	400 (0.07)	0.30	
8,000 (3.776)	860	2 (1.49)	930	3 (2.24)	960	3 (2.24)	NA	NA	NA	NA	NA	NA	NA	NA	NA	NA	400 (0.08)	0.31	

*External static pressure in inches of WC. Add the pressure drop of the duct furnace and the pressure drop of the ductwork to determine the total external static pressure.

Accessories [AC]

FACTORY INSTALLED

- A8 - INPUT DERATE**
Series QVED, QVES, QVSD
Factory Installed
Unit is derated up to 50% for specific applications.
- K4 - FAN TIME DELAY**
Series QVED, QVES, QVSD
Field Installed
Thermal bi metallic type time delay is standard on all units except duct furnaces. Provides a 60 delay on and 45 second delay off for blower operation.
- K5 - AIR FLOW PROVE SWITCH**
Series QVED, QVES, QVSD
Factory Installed
A Dwyer 1910-0 pressure switch with an operating range of 0.15 - 0.5 inches WC.
- M6 - OSHA TYPE FAN GUARD**
Series TF, SF
Factory installed available on series TF and SF only, standard on series GG. Required for installations that must conform to OSHA standards. Also known as fingerproof fan guards.
- M8 - DISCHARGE DUCT FLANGE ASSEMBLY**
Series TC, SC
Factory Installed
(Specify — No Charge)
Used in lieu of louvers on blower units for incorporating field duct work.
- P4 - TERMINAL BLOCK WIRING**
Series TF, TC, SF, SC, TD, QVED, QVES, QVSD
Factory Installed
Provides specific terminal designation for field wiring.
- P6 - SUMMER/WINTER SWITCH**
Series TF, TC, SF, SC, TD, QVED, QVES, QVSD
Factory Installed
Allows operation of fan or blower for ventilating purposes during hot summer months (manually operated).
- S1 - 409 STAINLESS STEEL BURNERS**
Series QVED, QVES, QVSD
Factory Installed
409 stainless steel burners in lieu of the standard aluminized steel burners.
- S3 - STAINLESS STEEL FLUE COLLECTOR**
Series TF, GG, TC, SF, SC
Factory Installed
409 Stainless steel flue collector in lieu of standard aluminized steel collector.
- S5 - STAINLESS STEEL BURNERS**
Series TF, TC, SF, SC
Factory Installed
304L Stainless steel in-shot burners in lieu of the standard aluminized steel in-shot burners.

FIELD INSTALLED

- A7 - PRESSURE REGULATOR 1/2-35 PSI**
All Series & Sizes
Field Installed
Required where main line pressure exceeds 14 inches WC (1/2 psig). Choose regulator based on three incoming pressure ranges: 1/2-10 PSI, 10-20 PSI, 20-35 PSI. One regulator per unit required, shipped separately.
- F1 - ONE STAGE DUCTSTAT**
Series TC, SC, TD, QVED, QVES, QVSD
Field Installed
Single pole, double throw. 55-175°F setpoint range.
[2" W x 5-5/8" H x 2-7/16" D]
- F2 - TWO STAGE DUCTSTAT**
Series TC, SC, TD, QVED, QVES, QVSD
Field Installed
Single pole, double throw. 55-175°F setpoint range.
[2" W x 5-5/8" H x 2-7/16" D]
- G1 - ONE STAGE T87K (MERCURY-FREE) THERMOSTAT WITH SUBBASE**
All Series and Sizes
Field Installed
Single stage heating thermostat with subbase. Includes fan switching relay. Standard round styling suitable for any decor. 40-90°F range.
- G2 - ONE STAGE T87K (MERCURY-FREE) THERMOSTAT WITH TG511A GUARD**
All Series and Sizes
Field Installed
Same features as "G1" except a tamper proof guard is included.
- G3 - ONE STAGE T834N (MERCURY-FREE) THERMOSTAT WITH FAN SWITCH**
All Series and Sizes
Field Installed
Single stage heating thermostat with fan switch. Manufactured exclusively for Sterling with a "Sterling" logo face plate. 50-90°F range.
[2-7/8" W x 4-3/4" H x 1-1/2" D]
- G5 - TWO STAGE TH5220D (MERCURY-FREE) THERMOSTAT WITH SUBBASE**
All Series and Sizes
Field Installed
Two stage heating and two stage cooling with system and fan switching and built in 10°F heating/cooling differential. Includes fan relay. Heating 40-90°F range, Cooling 50-99°F.
[5-13/16" W x 3-9/16" H x 1-1/2" D]
- G6 - LOCKING THERMOSTAT COVER**
All Series and Sizes
Field Installed
Universal locking thermostat cover for use with all thermostats listed.
- G9 - ONE STAGE T822K (MERCURY-FREE) THERMOSTAT**
All Series and Sizes
Field Installed
Single stage heating only thermostat with subbase. 24 volt operation. 50-90°F range.
[2-7/8" W x 4-3/4" H x 1-1/2" D]
- H5 - LOW AMBIENT CONTROL**
Series TF, TC, SF, SC, TD, QVED, QVES, QVSD
Field Installed
Disengages duct furnace(s) from firing in times of mild ambient temperatures.
- M2 - 1, 2, 3 - VENT CAP**
Series TF, TC, SF, SC, TD, QVED, QVES, QVSD
Field Installed
4 (QVED, QVES, QVSD only), 5 or 6 inch vent cap for use with series TF, TC, SF, SC, QVED, QVES, QVSD. Must indicate unit size when ordered.
- M3-1 - ADAPTOR**
Series QVED, QVES, QVSD
Field Installed
4 to 5 inch flue vent adaptor for use with 100 through 175 MBH power vented units. Power vented unit capacities 300, 350 and 400 require 5 to 6 inch flue vent adaptor which is supplied with the unit as standard equipment.
- M4 - VERTICAL CONCENTRIC FLUE KIT**
Series QVSD
Field Installed
Allows for one 8 inch vent/combustion air vertical penetration through a structure. Kit includes collection box, 5 inch flue gas vent cap and 8 inch combustion air inlet cap.
- M5- HORIZONTAL CONCENTRIC FLUE KIT**
Series QVSD
Field Installed
Allows for one 8 inch vent/combustion air horizontal penetration through a structure. Kit includes collection box, 5 inch flue gas vent cap and 8 inch combustion air inlet cap.
- M7- 2 to 4 POINT SUSPENSION KIT**
Series TF, SF
Field Installed
Kit converts 2 point unit heater suspension to 4 point.
- P2 - ADJUSTABLE HIGH LIMIT SWITCH**
Series QVED, QVES, QVSD
Field Installed
Adjustable switch used in conjunction with the standard header mounted high limit switch.

Accessories [AC]

- P3 - ADJUSTABLE FAN SWITCH**
 Series QVED, QVES, QVSD
Field Installed
 Adjustable switch used to cycle a separate blower.
- P5 - 24 VOLT RELAY**
 All Series and Sizes
Field Installed
 Specify purpose. 24 volt SPST relay.
- Q7 - HORIZONTAL AND VERTICAL LOUVERS**
 Series QVED, QVES, QVSD
Field Installed
 For four way deflection on duct.
- S4 - 409 STAINLESS STEEL DRAIN PAN**
 Series TD, QVED, QVES
Field Installed
 Condensate drain pan typically used when cooling coils are installed upstream of duct.
- VC - 4 VENT CAP**
 Series GG
Field Installed
 4 inch vent cap for use with series GG.
- X2 - 30° NOZZLE**
 Series GG, TF, TC, SF, SC
Field Installed
 Directs the discharge air at a 30° angle. Air can be directed up to 60° by adjusting the horizontal louvers. Louvers are supplied with the unit heater and must be reinstalled in the nozzle discharge. Must indicate unit size when ordered.
- X3 - 60° NOZZLE**
 Series GG, TF, TC, SF, SC
Field Installed
 Directs the discharge air at a 60° angle. Air can be directed up to 90° by adjusting the horizontal louvers. Louvers are supplied with the unit heater and must be reinstalled in the nozzle discharge. Must indicate unit size when ordered.
- X4 - 90° NOZZLE**
 Series GG, TF, TC, SF, SC
Field Installed
 Directs the discharge air at a 90° angle. Louvers are supplied with the unit heater and must be reinstalled in the nozzle discharge. Must indicate unit size when ordered.
- X5 - VERTICAL LOUVER KIT**
 Series TF, TC, SF, SC
Field Installed
 Vertical Louvers to provide 4 way air deflection. Must indicate unit size when ordered.
- X5 - HORIZONTAL AND VERTICAL LOUVERS**
 Series TD
Field Installed
 For four way deflection on duct.
- X7 - 4, 5 COMBUSTION AIR INLET KIT**
 Series GG
Field Installed
 Allows for one 6 or 8 inch vent/combustion air opening through a structure. One kit permits for either horizontal or vertical applications. *Kit required for converting a series GG to separated combustion.*
- X7 - H5, H6 HORIZONTAL COMBUSTION AIR INLET KIT**
 Series SF, SC
Field Installed
 Allows for one 8 or 10 inch horizontal vent/combustion air opening through a structure. Must indicate unit size when ordered.
- X7 - V5, V6 VERTICAL COMBUSTION AIR INLET KIT**
 Series SF, SC
Field Installed
 Allows for one 8 or 10 inch vertical vent/combustion air opening through a structure. Must indicate unit size when ordered.
- X8 - H5, H6 HORIZONTAL COMBUSTION AIR INLET KIT**
 Series TD
Field Installed
 Allows for one 8 or 10 inch horizontal vent/combustion air opening through a structure. *Kit required for converting series TD to separated combustion with single wall penetration.* Must indicate unit size when ordered.
- X8 - V5, V6 VERTICAL COMBUSTION AIR INLET KIT**
 Series TD
Field Installed
 Allows for one 8 or 10 inch vertical vent/combustion air opening through a structure. *Kit required for converting series TD to separated combustion with single roof penetration.* Must indicate unit size when ordered.
- X9 - DBL - 5, 6 AIR INLET KIT**
 Series TD
Field Installed
Kit required for converting series TD to separated combustion. Kit includes (1) M2 Vent Cap. Must indicate unit size when ordered.

Heat Throw Data

- NOTES:**
1. All throw data shown below is for tubular unit heaters only – excludes Series QVED, QVES, QVSD and CAB.
 2. All throw data figures are approximations. Allowances should be made for optimum performance, altitude, etc.
 3. “NR” - Units not recommended at these mounting heights.
 4. 30, 60 and 90 degree nozzles are shipped unassembled.

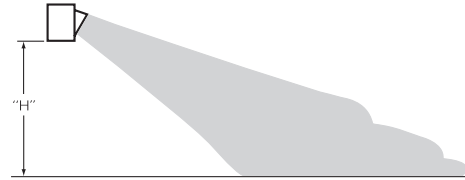
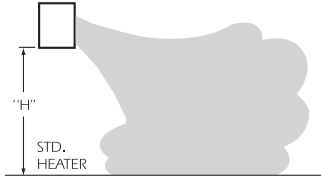

STANDARD UNIT HEATER APPLICATIONS

Distance From Floor to Bottom of Unit “H” Feet (m)	Approximate Distance of Heat Throw - Feet (Meters)			
	30,000 (8.8)	45,000 (13.2)	60,000 (17.6)	75,000 (22.0)
8 (2.4)	33 (10.1)	33 (10.1)	33 (10.1)	40 (12.2)
10 (3.0)	28 (8.5)	28 (8.5)	28 (8.5)	35 (10.7)
12 (3.7)	NR	NR	NR	NR
15 (4.6)	NR	NR	NR	NR
20 (6.1)	NR	NR	NR	NR
	UNIT SIZE BTU/HR (kW)			
	90,000 (26.4)	100,000 (29.3)	105,000 (30.8)	120,000 (34.2)
8 (2.4)	40 (12.2)	60 (18.3)	60 (18.3)	65 (19.8)
10 (3.0)	35 (10.7)	54 (16.5)	54 (16.5)	56 (17.1)
12 (3.7)	NR	44 (13.4)	44 (13.4)	46 (14.0)
15 (4.6)	NR	NR	NR	NR
20 (6.1)	NR	NR	NR	NR
	UNIT SIZE BTU/HR (kW)			
	125,000 (36.6)	150,000 (43.9)	175,000 (51.2)	200,000 (58.6)
8 (2.4)	65 (19.8)	70 (21.3)	75 (22.9)	80 (24.4)
10 (3.0)	56 (17.1)	60 (18.3)	64 (19.5)	68 (20.7)
12 (3.7)	46 (14.0)	49 (14.9)	57 (17.4)	61 (18.6)
15 (4.6)	NR	45 (13.7)	49 (14.9)	52 (15.8)
20 (6.1)	NR	NR	NR	46 (14.0)
	UNIT SIZE BTU/HR (kW)			
	250,000 (73.2)	300,000 (87.8)	350,000 (102.5)	400,000 (117.1)
8 (2.4)	90 (27.4)	105 (32.0)	110 (33.5)	120 (36.6)
10 (3.0)	78 (23.8)	90 (27.4)	95 (29.0)	100 (30.5)
12 (3.7)	68 (20.7)	80 (24.4)	84 (25.6)	90 (27.4)
15 (4.6)	60 (18.3)	70 (21.3)	74 (22.6)	80 (24.4)
20 (6.1)	54 (16.5)	63 (19.2)	66 (20.1)	70 (21.3)

30° NOZZLE

Distance From Floor to Bottom of Unit “H” Feet (m)	Approximate Distance of Heat Throw - Feet (Meters)			
	30,000 (8.8)	45,000 (13.2)	60,000 (17.6)	75,000 (22.0)
8 (2.4)	Data Not Available			
10 (3.0)	Data Not Available			
12 (3.7)	Data Not Available			
15 (4.6)	Data Not Available			
20 (6.1)	Data Not Available			
	UNIT SIZE BTU/HR (kW)			
	90,000 (26.4)	100,000 (29.3)	105,000 (30.8)	120,000 (34.2)
8 (2.4)	Data Not Available	65 (19.8)	Data Not Available	Data Not Available
10 (3.0)	Data Not Available	57 (17.4)	Data Not Available	Data Not Available
12 (3.7)	Data Not Available	50 (15.2)	Data Not Available	Data Not Available
15 (4.6)	Data Not Available	NR	Data Not Available	Data Not Available
20 (6.1)	Data Not Available	NR	Data Not Available	Data Not Available
	UNIT SIZE BTU/HR (kW)			
	125,000 (36.6)	150,000 (43.9)	175,000 (51.2)	200,000 (58.6)
8 (2.4)	70 (21.3)	75 (22.9)	80 (24.4)	85 (25.9)
10 (3.0)	60 (18.3)	64 (19.5)	68 (20.7)	72 (21.9)
12 (3.7)	54 (16.5)	57 (17.4)	60 (18.3)	64 (19.5)
15 (4.6)	45 (13.7)	48 (14.6)	50 (15.2)	53 (16.2)
20 (6.1)	NR	NR	44 (13.4)	47 (14.3)
	UNIT SIZE BTU/HR (kW)			
	250,000 (73.2)	300,000 (87.8)	350,000 (102.5)	400,000 (117.1)
8 (2.4)	95 (29.0)	115 (35.1)	120 (36.6)	125 (38.1)
10 (3.0)	86 (26.2)	99 (30.2)	105 (32.0)	110 (33.5)
12 (3.7)	77 (23.5)	88 (26.8)	94 (28.7)	100 (30.5)
15 (4.6)	64 (19.5)	74 (22.6)	79 (24.1)	84 (25.6)
20 (6.1)	58 (17.7)	66 (20.1)	71 (21.6)	75 (22.9)

Heat Throw Data

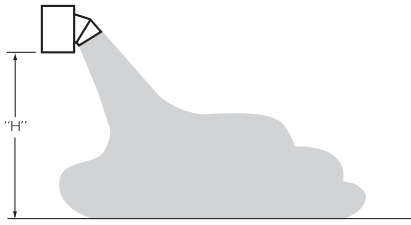

60° NOZZLE

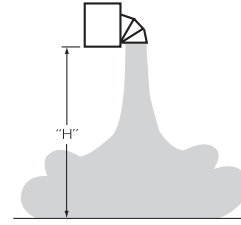

90° NOZZLE*

Distance From Floor to Bottom of Unit "H" Feet (m)	Approximate Distance of Heat Throw - Feet (Meters)			
	30,000 (8.8)	UNIT SIZE BTU/HR (kW)		
		45,000 (13.2)	60,000 (17.6)	75,000 (22.0)
8 (2.4)	Data Not Available			
10 (3.0)	Data Not Available			
12 (3.7)	Data Not Available			
15 (4.6)	Data Not Available			
20 (6.1)	Data Not Available			
		UNIT SIZE BTU/HR (kW)		
	90,000 (26.4)	100,000 (29.3)	105,000 (30.8)	120,000 (34.2)
8 (2.4)	Data Not Available	75 (22.9)	Data Not Available	Data Not Available
10 (3.0)	Data Not Available	65 (19.8)	Data Not Available	Data Not Available
12 (3.7)	Data Not Available	60 (18.3)	Data Not Available	Data Not Available
15 (4.6)	Data Not Available	50 (15.2)	Data Not Available	Data Not Available
20 (6.1)	Data Not Available	NR	Data Not Available	Data Not Available
		UNIT SIZE BTU/HR (kW)		
	125,000 (36.6)	150,000 (43.9)	175,000 (51.2)	200,000 (58.6)
8 (2.4)	80 (24.4)	85 (25.9)	90 (27.4)	95 (29.0)
10 (3.0)	70 (21.3)	75 (22.9)	79 (24.1)	83 (25.3)
12 (3.7)	64 (19.5)	68 (20.7)	72 (21.9)	76 (23.2)
15 (4.6)	54 (16.5)	56 (17.1)	61 (18.6)	65 (19.8)
20 (6.1)	49 (14.9)	52 (15.8)	55 (16.8)	59 (18.0)
		UNIT SIZE BTU/HR (kW)		
	250,000 (73.2)	300,000 (87.8)	350,000 (102.5)	400,000 (117.1)
8 (2.4)	110 (33.5)	125 (38.1)	130 (39.6)	138 (42.1)
10 (3.0)	95 (29.0)	109 (33.2)	115 (35.1)	120 (36.6)
12 (3.7)	84 (25.6)	100 (30.5)	103 (31.4)	108 (32.9)
15 (4.6)	71 (21.6)	85 (25.9)	88 (26.8)	94 (28.7)
20 (6.1)	65 (19.8)	77 (23.5)	81 (24.7)	85 (25.9)

Distance From Floor to Bottom of Unit "H" Feet (m)	Approximate Distance of Heat Throw - Feet (Meters)		
	UNIT SIZE BTU/HR (kW)		
	100,000 (29.3)	125,000 (36.6)	150,000 (43.9)
10 (3.0)	NR	NR	NR
15 (4.6)	30 (9.1) x 25 (7.6)	35 (10.7) x 30 (9.1)	40 (12.2) x 35 (10.7)
20 (6.1)	NR	NR	NR
25 (7.6)	NR	NR	NR
30 (9.1)	NR	NR	NR
		UNIT SIZE BTU/HR (kW)	
	175,000 (51.2)	200,000 (58.6)	250,000 (73.2)
10 (3.0)	NR	NR	NR
15 (4.6)	45 (13.7) x 40 (12.2)	50 (15.2) x 40 (12.2)	60 (18.3) x 45 (13.7)
20 (6.1)	NR	40 (12.2) x 35 (10.7)	56 (17.1) x 40 (12.2)
25 (7.6)	NR	NR	50 (15.2) x 35 (10.7)
30 (9.1)	NR	NR	NR
		UNIT SIZE BTU/HR (kW)	
	300,000 (87.8)	350,000 (102.5)	400,000 (117.1)
10 (3.0)	NR	NR	NR
15 (4.6)	70 (21.3) x 45 (13.7)	80 (24.4) x 50 (15.2)	100 (30.5) x 50 (15.2)
20 (6.1)	65 (19.8) x 40 (12.2)	70 (21.3) x 45 (13.7)	80 (24.4) x 45 (13.7)
25 (7.6)	60 (18.3) x 35 (10.7)	65 (19.8) x 40 (12.2)	75 (22.9) x 40 (12.2)
30 (9.1)	55 (16.8) x 35 (10.7)	60 (18.3) x 35 (10.7)	65 (19.8) x 40 (12.2)

*It is not recommended to mount a unit with a 90° nozzle at 10 feet or less. Heat Throw data for GG Series units with a 90° nozzle installed is not currently available.

Nozzle Dimensions*

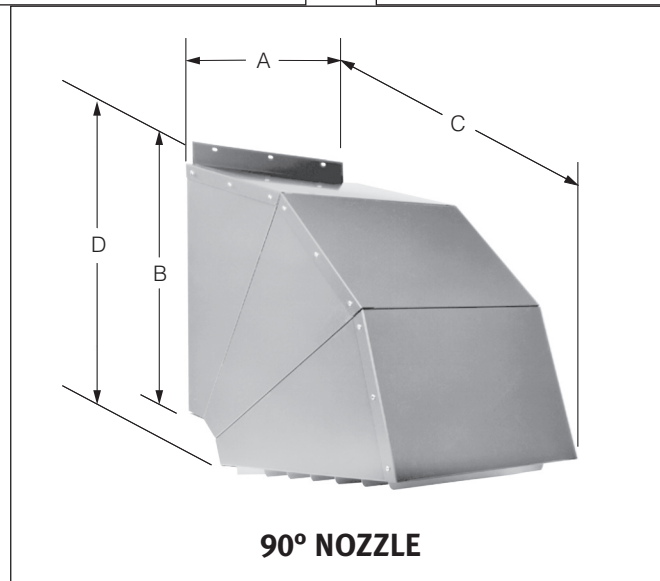
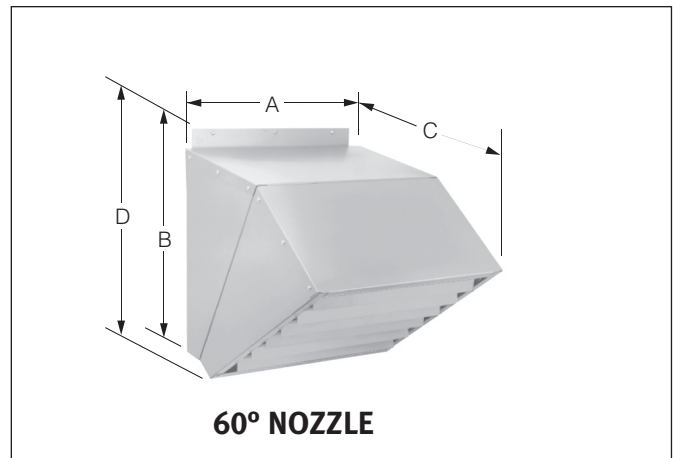
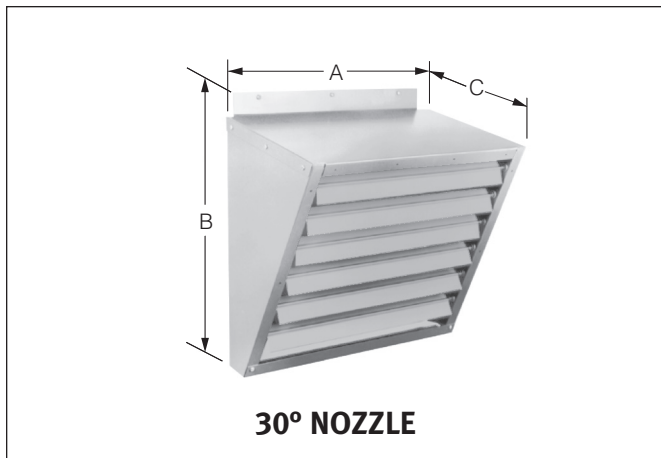

*Nozzles are field assembled.

NOZZLE DIMENSIONAL DATA CHART

DIMENSION	NOZZLE TYPE	30, 45	60, 75	90, 105, 120	100, 125, 150	175, 200, 250	300, 350, 400
WIDTH A Inches (mm)	30°	19-5/8 (498)	19-5/8 (498)	19-5/8 (498)	20-3/4 (527)	32-3/4 (832)	50-3/4 (1289)
	60°	19-5/8 (498)	19-5/8 (498)	19-5/8 (498)	20-3/4 (527)	32-3/4 (832)	50-3/4 (1289)
	90°	19-5/8 (498)	19-5/8 (498)	19-5/8 (498)	20-3/4 (527)	32-3/4 (832)	50-3/4 (1289)
HEIGHT B Inches (mm)	30°	12-1/16 (306)	15-5/8 (397)	22-3/8 (568)	31-1/2 (800)	31-1/2 (800)	31-1/2 (800)
	60°	12-1/16 (306)	15-5/8 (397)	22-3/8 (568)	31-1/2 (800)	31-1/2 (800)	31-1/2 (800)
	90°	12-1/16 (306)	15-5/8 (397)	22-3/8 (568)	31-1/2 (800)	31-1/2 (800)	31-1/2 (800)
FURTHEST DEPTH C Inches (mm)	30°	13-1/8 (333)	13-1/8 (333)	13-1/8 (333)	15 (381)	15 (381)	15 (381)
	60°	22-3/16 (564)	22-3/16 (564)	22-3/16 (564)	25-1/2 (648)	25-1/2 (648)	25-1/2 (648)
	90°	25-9/16 (694)	25-9/16 (694)	25-9/16 (694)	28-1/4 (718)	28-1/4 (718)	28-1/4 (718)
HEIGHT WITH OVERHANG D Inches (mm)	30°	N/A					
	60°	13-5/16 (338)	16-7/8 (429)	23-5/8 (600)	30 (762)	30 (762)	30 (762)
	90°	15-1/4 (387)	18-13/16 (478)	25-9/16 (649)	34 (864)	34 (864)	34 (864)

GG Series Typical Standard Specification

Furnish and install, where indicated or scheduled on plans, gas-fired unit heaters manufactured by Sterling HVAC. All heaters are to have a minimum thermal efficiency of 82%. The heat exchanger consists of aluminized steel tubes not lighter than 20-gauge. Burner system is to be of the “single-orifice burner” design. A direct spark ignition system with integrated control and redundant gas valve shall be utilized. Flame rectification shall be independent of the spark igniter, allowing true indication of complete ignition of the burner. Most cabinetry and trim pieces shall be fabricated of 20-gauge material, and finished with a baked gray enamel.

Separated combustion style units must utilize clean air from the outside of the structure for combustion purposes. A concentric type adapter must be used at the point of building termination. This adapter will allow for the outside air to enter and combustion flue gases exit through one opening.

Heaters shall be equipped with a 120/24 volt transformer; factory wiring shall permit the use of propeller fan for continuous air circulation when combined with manufacturers (optional) 24 volt summer/winter single stage thermostat. The control transformer and pressure switch shall be factory mounted in a main control cabinet located on the side of the unit; the side panel is removed to create easy access and all wiring information will be indicated on the inside control cabinet.

Units will be equipped with a low voltage automatic reset high temperature control, wired to de-energize the main gas valve and maintain fan operation until the high temperature control resets. Units will be equipped with 120/1/60 volt motors which include internal automatic reset thermal overload protection. Fans will be hubbed with aluminum blades and have OSHA-approved fan guard protection. Adjustable and individually removable horizontal louver blades shall be provided for directing air flow.

All units and component assemblies shall be warranted for a period of one year from the date of shipment from the factory or 18 months from the date of manufacture, whichever occurs first. All burners, heat exchangers, and flue collectors shall carry a ten year non-prorated limited warranty on materials and workmanship (subject to appropriate disclaimers).

TF/TC Series Typical Standard Specification

Furnish and install, where indicated or scheduled on plans, gas-fired unit heaters manufactured by Sterling HVAC. All heaters are to have a minimum thermal efficiency of 83%. The heat exchanger consists of aluminized steel tubes not lighter than 20-gauge. Burners are to be of the “in-shot” design. A direct spark ignition system with integrated control and redundant gas valve shall be utilized. Flame rectification shall be independent of the spark igniter allowing true indication of complete ignition of the burner. Most cabinetry and trim pieces shall be fabricated of 20-gauge material and finished with a baked gray enamel.

All line voltage wiring shall be completely enclosed in flexible conduit. Heaters shall be equipped with a 120/24 volt controls transformer. Factory wiring shall permit the use of propeller fan

on TF units and blower on TC units, for continuous air circulation when combined with manufacturer’s (optional) 24-volt summer/winter single stage thermostat. The control transformer and pressure switch shall be factory mounted in a main control panel located on the side of the unit; this panel creates easy access and all wiring information will be indicated on the inside control panel door.

Units will be equipped with a low voltage automatic reset high temperature control, wired to de-energize the main gas valve and maintain fan or blower operation until the high temperature control resets. Units will be equipped with 120/1/60 volt motors, which include internal automatic reset thermal overload protection. TF unit fans will be hubbed with aluminum blades and have fan guard protection. TF units with inputs greater than 250,000’s BTU’s shall be equipped with dual motors and fan blades for optimum air distribution. TC units shall have centrifugal blowers with an OSHA-type belt guard. TC units with inputs greater than 250,000 BTU’s shall be equipped with dual blowers on a single shaft for optimum air distribution. Adjustable and individually removable horizontal louver blades shall be provided on all units for directing air flow.

All units and component assemblies shall be warranted for a period of one year from the date of shipment from the factory or 18 months from the date of manufacture, whichever occurs first. All burners, heat exchangers, and flue collectors shall carry a ten year non-prorated limited warranty on materials and workmanship (subject to appropriate disclaimers).

SF/SC Series Typical Standard Specification

Furnish and install, where indicated or scheduled on plans, gas-fired unit heaters manufactured by Sterling HVAC. All heaters to be designed to separate the combustion process from the environment where the units are installed; the burners, igniter and flue system will be enclosed within the unit and a power venting system will both draw in combustion air from outside the space and exhaust flue gas products to the outside. All heaters are to have a minimum thermal efficiency of 83%. The heat exchanger consists of aluminized steel tubes not lighter than 20-gauge. Burners are to be of the “in-shot” design. A direct spark ignition system with integrated control and redundant gas valve shall be utilized. Flame rectification shall be independent of the spark igniter allowing true indication of complete ignition of the burner. Most cabinetry and trim pieces shall be fabricated of 20-gauge material and finished with baked gray enamel.

All line voltage wiring shall be completely enclosed in flexible conduit. Heaters shall be equipped with a 120/24 volt controls transformer. Factory wiring shall permit the use of propeller fan on SF units and blower on SC units for continuous air circulation when combined with manufacturer’s (optional) 24-volt summer/winter single stage thermostat. The control transformer and pressure switch shall be factory mounted in a main control panel located on the side of the unit; this panel creates easy access and all wiring information will be indicated on the inside control panel door.

Units will be equipped with a low voltage automatic reset high temperature control, wired to de-energize the main gas valve and maintain fan or blower operation until the high temperature control resets. Units will be equipped with 120/1/60 volt motors, which include internal automatic reset thermal overload protection. SF unit fans will be hubbed with aluminum blades and have fan guard protection. SF units with inputs greater than 250,000 BTU’s shall be equipped with dual motors and fan blades on a single shaft for optimum air distribution. SC units shall have centrifugal blowers

with an OSHA-type belt guard. SC units with inputs greater than 250,000 BTU's shall be equipped with dual blowers on a single shaft for optimum air distribution. Adjustable and individually removable horizontal louver blades shall be provided on all units for directing air flow.

Units to be vented horizontally or vertically via standard two-pipe configuration. When necessary to vent concentrically through one wall or roof penetration, an optional combustion air inlet kit will be made available.

All units and component assemblies shall be warranted for a period of one year from the date of shipment from the factory or 18 months from the date of manufacture, whichever occurs first. All burners, heat exchangers, and flue collectors shall carry a ten year non-prorated limited warranty on materials and workmanship (subject to appropriate disclaimers).

TD Series Typical Standard Specification

Furnish and install where shown on plans, Gas-Fired Tubular Duct Furnaces as made by Sterling HVAC.

All units and components are to be warranted (subject to appropriate disclaimers) from defects in material and workmanship for a period of one year from date of shipment from the factory. Heat Exchanger, draft hood assembly, and burners will be free from defects in material or workmanship for a period of ten (10) years from the date of manufacture.

Sterling HVAC Model TD Tubular Duct Furnaces are completely factory assembled, piped, wired and test fired. All models are ETL certified as having 82% thermal efficiency and for operation on either natural or LP (propane) gas. All models conform to the latest ANSI Standards for safe and efficient performance.

All sizes have exceptionally low pressure drop, making it possible to handle large volumes of air without using an axillary by-pass. Sterling HVAC duct furnaces are tested to operate against 2.0 inches water column pressure.

Casings shall be double wall construction consisting of a 20-gauge exterior panel, 1/2 inch Microlite insulation and 16-gauge interior liner. Exterior and interior panels shall be finished in baked enamel. Burners shall be aluminized steel and shall be of in-shot design. Heat exchangers and flue collector shall be aluminized steel or 409 stainless steel. Tubes shall not be lighter than 20-gauge.

All models are equipped with direct spark ignition, 115 volt power venter, vent system pressure switch, high limit switch, fan time delay and 24 volt control transformer. Units are provided with a four-point suspension system.

All models must be vented utilizing our standard two-pipe method or our optional certified Air Inlet Kit or Combustion Air Inlet kit for concentric venting.

QVED/QVES/QVSD Series Typical Standard Specification

Furnish and install where shown on plans, gas-fired duct furnaces as made by Sterling HVAC. Burners shall be pressed aluminized steel or 409 stainless steel, and shall have stainless steel port protectors. Heat exchangers shall be aluminized steel, 409 stainless steel or 321 stainless steel. Tubes shall not be lighter than 20-gauge. Headers shall not be lighter than 18-gauge. Furnaces to be of neat appearance and good workmanship. All units and components are to be warranted (subject to appropriate disclaimers) from defects in material and workmanship for a period of one year from date of shipment from the factory.

All sizes have exceptionally low pressure drop, making it possible to handle large volumes of air without using an axillary by-pass. Sterling duct furnaces are tested to operate against 2.0 inches water column pressure.

All models are equipped with electronic spark ignition (100% safety shutoff on LP models), 115 volt power venter, vent system pressure switch, high limit switch, fan time delay and 24 volt control transformer.

Indoor Duct Furnaces are completely factory assembled, piped, wired and test fired. All models conform to the latest ANSI Standards for safe and efficient performance. Units are provided with a four-point suspension system and are available for operation on either natural or LP gas.

Casings are die-formed 20-gauge bonderized steel, finished in baked enamel. Burners are accessible through a removable, bottom panel (QVED & QVSD only). Burners are accessible through a removable, side panel (QVES only).

All models are equipped with a 24 volt control system, which is powered by a factory installed 115/24 volt transformer, Electronic Spark Ignition and Integral Power Venting with a sealed flue collector.

CAB Series Typical Standard Specification

Cabinet blowers shall be as made by Sterling HVAC consisting of a 20-gauge aluminized steel cabinet, with removable side panels, centrifugal fan, motor and filters. Motor and drive shall be furnished by the factory and shipped fully mounted so that field mounting is not required. Motor pulley shall be adjustable as to pitch diameter. When a cabinet blower-duct furnace combination is required, the manufacturer shall furnish the standard cataloged duct transition piece. Furnaces shall be of neat appearance and good workmanship. All units and components are to be warranted (subject to appropriate disclaimers) from defects in materials and workmanship for a period of one year from the date of shipment from the factory.

Tubular Unit Heaters and TD Duct Furnaces

LIMITED WARRANTY

1. Sterling (“the Manufacturer”) warrants to the original owner at original installation site that the above models of Sterling Gas-Fired Heaters (“the Product”) will be free from defects in material or workmanship for one (1) year from the date of shipment from the factory, or one and one-half (1-1/2) years from the date of manufacture, whichever occurs first. Sterling further warrants that the complete heat exchanger, flue collector, and burners will be free from defects in material or workmanship for a period of ten (10) years from the date of manufacture. If upon examination by the Manufacturer the Product is shown to have a defect in material or workmanship during the warranty period, the Manufacturer will repair or replace, at its option, that part of the Product which is shown to be defective.
2. This limited warranty does not apply:
 - (a) if the Product has been subjected to misuse or neglect, has been accidentally or intentionally damaged, has not been installed, maintained or operated in accordance with the furnished written instructions, or has been altered or modified in any way by any unauthorized person.
 - (b) to any expenses, including labor or material, incurred during removal or reinstallation of the Product.
 - (c) to any damage due to corrosion by chemicals, including halogenated hydrocarbons, precipitated in the air.
 - (d) to any workmanship of the installer of the Product.
3. This limited warranty is conditional upon:
 - (a) advising the installing contractor, who will in turn notify the distributor or manufacturer.
 - (b) shipment to the Manufacturer of that part of the Product thought to be defective. Goods can only be returned with prior written approval of the Manufacturer. All returns must be freight prepaid.
 - (c) determination in the reasonable opinion of the Manufacturer that there exists a defect in material or workmanship.
4. Repair or replacement of any part under this Limited Warranty shall not extend the duration of the warranty with respect to such repaired or replaced part beyond the stated warranty period.
5. **THIS LIMITED WARRANTY IS IN LIEU OF ALL OTHER WARRANTIES, EITHER EXPRESS OR IMPLIED, AND ALL SUCH OTHER WARRANTIES, INCLUDING WITHOUT LIMITATION IMPLIED WARRANTIES OF MERCHANTABILITY OR FITNESS FOR A PARTICULAR PURPOSE, ARE HEREBY DISCLAIMED AND EXCLUDED FROM THIS LIMITED WARRANTY. IN NO EVENT SHALL THE MANUFACTURER BE LIABLE IN ANY WAY FOR ANY CONSEQUENTIAL, SPECIAL, OR INCIDENTAL DAMAGES OF ANY NATURE WHATSOEVER, OR FOR ANY AMOUNTS IN EXCESS OF THE SELLING PRICE OF THE PRODUCT OR ANY PARTS THEREOF FOUND TO BE DEFECTIVE. THIS LIMITED WARRANTY GIVES THE ORIGINAL OWNER OF THE PRODUCT SPECIFIC LEGAL RIGHTS. YOU MAY ALSO HAVE OTHER RIGHTS WHICH MAY VARY BY EACH JURISDICTION.**

Duct Furnaces, Cabinet Blowers

1 YEAR LIMITED WARRANTY UNIT TYPE QVES, QVED, QVSD, CAB 1-4

Duct Furnaces, Separated Combustion Unit Heaters and Cabinet Blowers are warranted by Sterling to be free from defects in materials and workmanship for a period of one (1) year from date of shipment from Sterling’s Plant.

Sterling will repair or replace, at its option, any components which, upon inspection, it finds to be defective, provided that the unit has been operated within its listed capacity, has been installed in accordance with the furnished instructions, has not been misused or subject to negligence and has received reasonable and necessary maintenance.

This warranty does not cover loss due to corrosion by chemicals precipitated in the air such as halogenated hydrocarbons.

Sterling will in no event be liable for incidental or consequential damages of any kind whatsoever.

Written permission is required prior to the return of defective components. All returns must be sent with all transportation charges prepaid to the plant designated in the written permission.



STERLING®

HVAC PRODUCTS

260 NORTH ELM ST. WESTFIELD, MA 01085
(413) 564-5540 • FAX: (413) 562-5311
www.sterlinghvac.com



A MESTEK COMPANY