



COMMERCIAL HIGH PERFORMANCE 10

Electric Heated Air Curtain

Data Sheet

For Mounting Heights To 10' (environmental separation)

STANDARD CONSTRUCTION

- 14" high x 15" deep
- 1/2 hp three speed motor(s)
- Factory installed fan speed/heat switch
- White or black aluminum exterior cover (Optional: Custom Color or Stainless)
- Wall & Top Mounting

- Patented venturi open helical element with point suspension
 - Thermal overload protection
 - Galvanized steel frame
- Alternate kW: see sheet EP-112

2 Year Limited Warranty



MODEL	Nozzle Width (in)	Max Vel. at Nozzle (fpm)	Avg. Outlet Vel. (fpm)	Air Volume (cfm)	Outlet Vel. Uniformity	Power Rating (kW)	Motor(s) @ hp	Max Electric Capacity (kW)	Heater Output (MBH)	Air Temp. Rise (°F)	Net Wt. (lbs)
CHC10-1036E	36.00	5,917	1,990	1,741	61%	0.73	1 @ 1/2	14.0	47.8	25°	52
CHC10-1042E	42.00	4,418	1,748	1,784	54%	0.74	1 @ 1/2	14.0	47.8	25°	55
CHC10-1048E	48.00	3,815	1,515	1,768	62%	0.75	1 @ 1/2	14.0	47.8	25°	56
CHC10-1060E	60.00	2,930	1,184	1,726	48%	0.73	1 @ 1/2	14.0	47.8	26°	63
CHC10-2060E	60.00	3,963	1,801	2,626	74%	1.21	2 @ 1/2	21.0	71.7	25°	96
CHC10-2072E	72.00	5,917	1,990	3,482	61%	1.45	2 @ 1/2	28.0	95.6	25°	104
CHC10-2084E	87.00	4,418	1,687	3,568	54%	1.49	2 @ 1/2	28.0	95.6	25°	110
CHC10-2096E	99.00	3,815	1,470	3,536	62%	1.49	2 @ 1/2	28.0	95.6	25°	112
CHC10-3096E	99.00	2,930	1,815	4,367	61%	1.93	3 @ 1/2	35.0	119.5	25°	148
CHC10-2108E	111.00	3,963	1,295	3,494	48%	1.48	2 @ 1/2	28.0	95.6	25°	119
CHC10-3108E	111.00	5,917	1,936	5,223	61%	2.18	3 @ 1/2	42.0	143.3	25°	156
CHC10-2120E	116.25	2,930	1,222	3,452	48%	1.47	2 @ 1/2	28.0	95.6	26°	126
CHC10-3120E	116.25	4,418	1,864	5,266	54%	2.19	3 @ 1/2	42.0	143.3	25°	159

1. NOTE: Operation at 50 Hz will generate approximately a 17% reduction in air performance.
 2. Performance data based on AMCA licensed data from unheated units.
 Berner does not recommend CHC10-1060E, CHC10-2108E & CHC10-2120E, exists only as an equivalent to competitors' models.
 See sheet EP-112 for amp draws/total load requirements and alternate kW.

MODEL NUMBER CONFIGURATION

CHC10-1 036 E B-R-SS

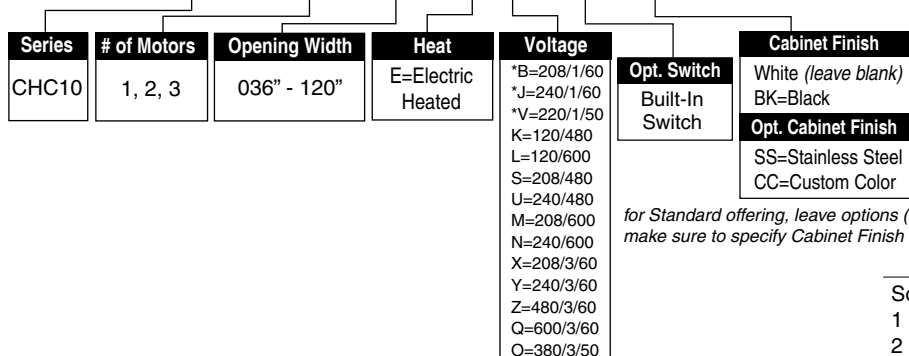

for Standard offering, leave options (Opt.) blank
 make sure to specify Cabinet Finish if other than white

Sound level measured 10' (3m) from the unit in free field:		
1 motor:	Low/Medium/High Speed:	64/65/66 dBA
2 motors 60":	Low/Medium/High Speed:	66/67/68 dBA
2 motors:	Low/Medium/High Speed:	67/68/69 dBA
3 motors:	Low/Medium/High Speed:	70/71/72 dBA

*Max 15kW
 See sheet EP-112
 for available lengths and voltages

Berner reserves the right to alter specifications without prior notice.



COMMERCIAL HIGH PERFORMANCE 10

Electric Heated Air Curtain

Electrical Performance Sheet

MODEL	kW (suffix)	Temp Rise °F	208/1/60 (voltage code B) MOTOR AMP DRAW = 3.5 each			240/1/60 (voltage code J) or 220/1/50 (voltage code V) MOTOR AMP DRAW = 3.5 each			208/3/60 (voltage code X) MOTOR AMP DRAW = 3.5 each			240/3/60 (voltage code Y) MOTOR AMP DRAW = 3.5 each		
			# CKTS	AMPS PER CIRCUIT (including motor)	BREAKER RATING PER CIRCUIT	# CKTS	AMPS PER CIRCUIT (including motor)	BREAKER RATING PER CIRCUIT	# CKTS	AMPS PER CIRCUIT (including motor)	BREAKER RATING PER CIRCUIT	# CKTS	AMPS PER CIRCUIT (including motor)	BREAKER RATING PER CIRCUIT
CHC10-1036E CHC10-1042E CHC10-1048E CHC10-1060E	14 (140)	25	2	26.0/44.9	35/60	2	23.0/38.9	30/50	1	42.4	60	1	37.2	50
	10 (100)	18	2	19.5/32.0	25/40	1	45.2	60	1	31.3	40	1	27.6	35
	8 (080)	14	1	42.0	60	1	36.8	50	1	25.7	35	1	22.7	30
	6 (060)	11	1	32.3	45	1	28.5	40	1	20.2	30	1	17.9	25
CHC10-2060E	21 (210)	25	-	N/A	N/A	-	N/A	N/A	2	26.4/38.9	35/50	2	23.8/33.7	30/45
	15 (150)	18	2	31.0/48.1	40/60	2	27.8/41.7	35/60	1	48.6	60	1	43.1	60
	12 (120)	14	2	26.2/38.5	35/50	2	23.7/33.3	30/45	1	40.3	50	1	35.9	45
	9 (090)	11	2	21.4/28.8	30/40	1	44.5	60	1	32.0	40	1	28.7	35
CHC10-2072E CHC10-2084E CHC10-2096E CHC10-2108E CHC10-2120E	28 (280)	25	-	N/A	N/A	-	N/A	N/A	2	45.9/38.9	60/50	2	40.7/33.7	50/45
	20 (200)	18	-	N/A	N/A	2	N/A	N/A	2	34.8/27.8	45/35	2	31.1/24.1	40/35
	16 (160)	14	2	45.5/38.5	60/50	2	40.3/33.3	50/45	2	29.2/22.2	40/30	1	45.5	60
	12 (120)	11	2	35.8/28.8	45/40	2	32.0/25.0	40/35	1	40.3	50	1	35.9	45
CHC10-3096E	35 (350)	25	-	N/A	N/A	-	N/A	N/A	3	29.9/38.9/38.9	40/50/50	3	27.3/33.7/33.7	35/45/45
	25 (250)	18	-	N/A	N/A	-	N/A	N/A	2	38.3/41.6	50/60	2	34.6/36.1	45/50
	20 (200)	14	-	N/A	N/A	-	N/A	N/A	2	32.7/33.3	40/45	2	29.7/28.9	40/40
	15 (150)	11	2	39.3/43.3	50/60	2	35.5/37.5	45/50	2	27.2/25.0	35/35	2	24.9/21.7	30/30
CHC10-3108E CHC10-3120E	42 (420)	25	-	N/A	N/A	-	N/A	N/A	3	49.4/38.9/38.9	60/50/50	3	44.2/33.7/33.7	60/45/45
	30 (300)	18	-	N/A	N/A	-	N/A	N/A	3	38.3/27.8/27.8	50/35/35	2	34.6/48.1	45/60
	24 (240)	14	-	N/A	N/A	-	N/A	N/A	2	32.7/44.4	40/60	2	29.7/38.5	40/50
	18 (180)	11	-	N/A	N/A	-	N/A	N/A	2	27.2/33.3	35/45	2	24.9/28.9	30/40



COMMERCIAL HIGH PERFORMANCE 10

Electric Heated Air Curtain

Electrical Performance Sheet

MODEL	kW (suffix)	Temp Rise °F	480/3/60 (voltage code Z) MOTOR AMP DRAW = 1.4 each			600/3/60 (voltage code Q) MOTOR AMP DRAW = 1.0 each			380/3/50 (voltage code O) MOTOR AMP DRAW = 3.5 each		
			# CKTS	AMPS PER CIRCUIT (including motor)	BREAKER RATING PER CIRCUIT	# CKTS	AMPS PER CIRCUIT (including motor)	BREAKER RATING PER CIRCUIT	# CKTS	AMPS PER CIRCUIT (including motor)	BREAKER RATING PER CIRCUIT
CHC10-1036E CHC10-1042E CHC10-1048E CHC10-1060E	14 (140)	25	1	18.2	25	1	14.5	20	1	24.8	35
	10 (100)	18	1	13.4	20	1	10.6	15	1	18.7	25
	8 (080)	14	1	11.0	15	1	8.7	15	1	15.7	20
	6 (060)	11	1	8.6	15	1	6.8	15	1	12.6	20
CHC10-2060E	21 (210)	25	1	28.1	35	1	22.2	30	1	38.9	50
	15 (150)	18	1	20.8	30	1	16.4	25	1	29.8	40
	12 (120)	14	1	17.2	25	1	13.5	20	1	25.2	35
	9 (090)	11	1	13.6	20	1	10.7	15	1	20.7	25
CHC10-2072E CHC10-2084E CHC10-2096E CHC10-2108E CHC10-2120E	28 (280)	25	1	36.5	50	1	28.9	40	2	28.3/21.3	35/30
	20 (200)	18	1	26.9	35	1	21.2	30	1	37.4	50
	16 (160)	14	1	22.0	30	1	17.4	25	1	31.3	40
	12 (120)	11	1	17.2	25	1	13.5	20	1	25.2	35
CHC10-3096E	35 (350)	25	1	46.3	60	1	36.7	50	2	31.8/31.9	40/40
	25 (250)	18	1	34.3	45	1	27.1	35	1	48.5	60
	20 (200)	14	1	28.3	35	1	22.2	30	1	40.9	50
	15 (150)	11	1	22.2	30	1	17.4	25	1	33.3	40
CHC10-3108E CHC10-3120E	42 (420)	25	2	21.0/33.7	30/45	1	43.4	60	2	31.8/42.5	40/60
	30 (300)	18	1	40.3	50	1	31.9	40	2	25.7/30.4	35/40
	24 (240)	14	1	33.1	45	1	26.1	35	1	47.0	60
	18 (180)	11	1	25.9	35	1	20.3	25	1	37.8	50

CHC10 ELECTRIC HEATED

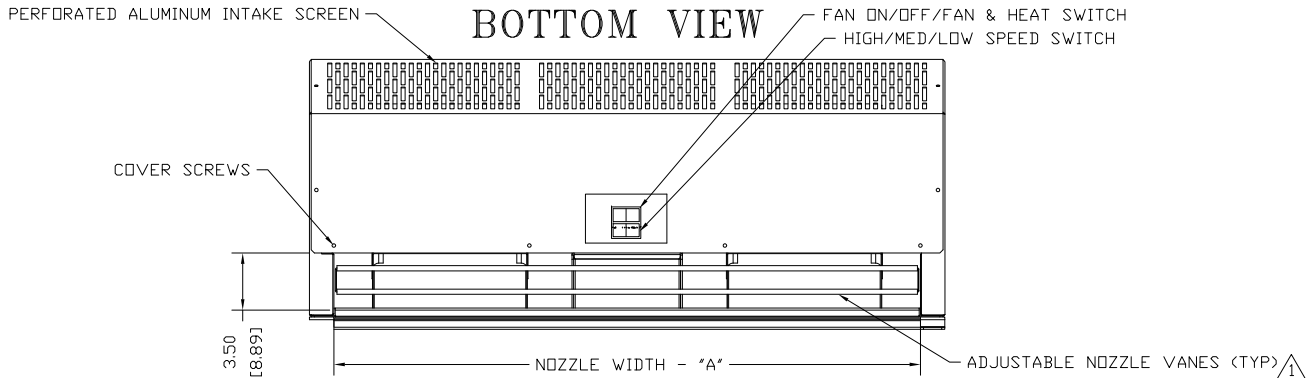
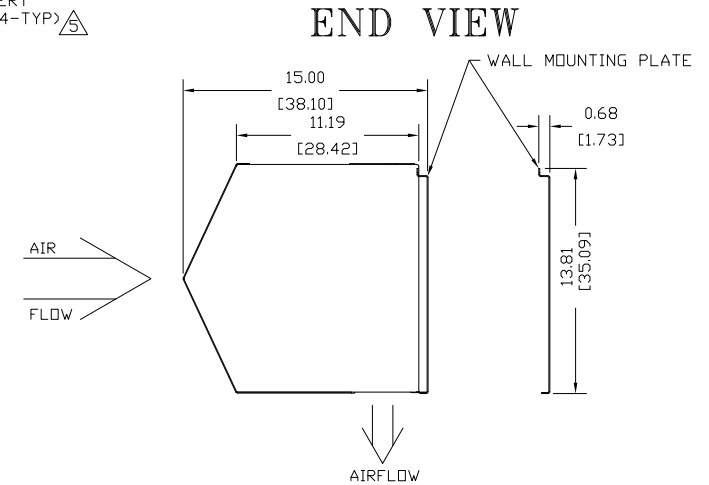
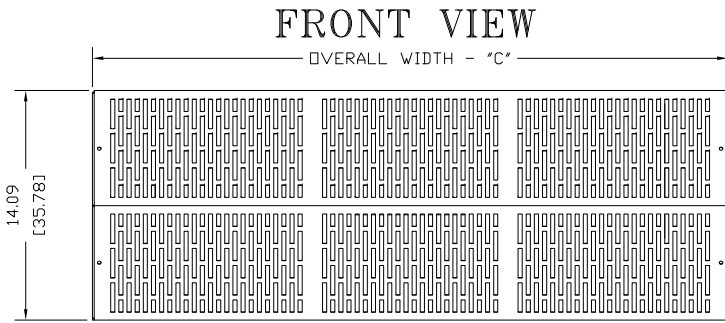
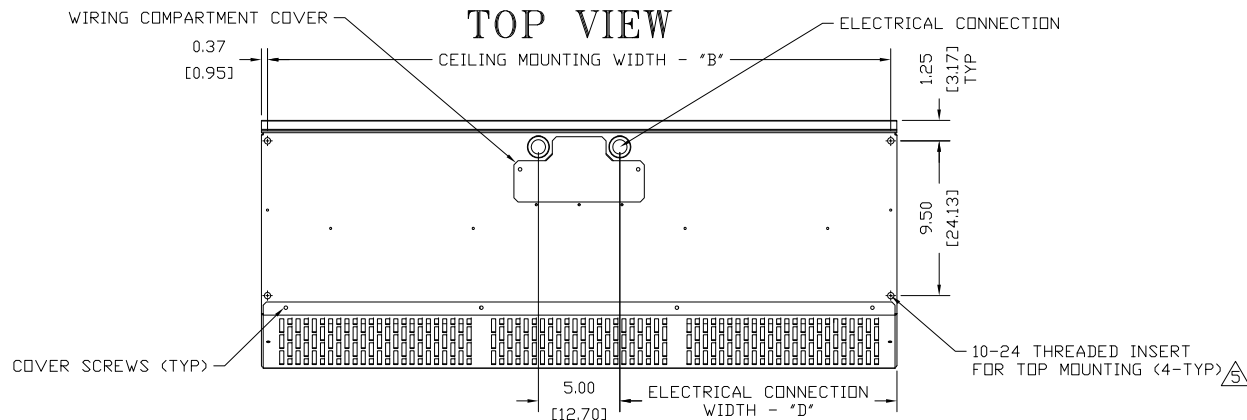

NOTES:

- ① AIR CURTAIN MUST BE INSTALLED SO AIR STREAM IS NOT OBSTRUCTED WHEN DEFLECTED 20° TO EITHER SIDE OF C.
- ② ELECTRICAL CONNECTIONS TO BE FLEXIBLE.
- ③ FIELD VERIFY DIMENSIONS.
- ④ ANCHORS TO SUPPORTING STRUCTURE BY OTHERS.
- ⑤ ADEQUACY OF SUPPORTING STRUCTURE IS TO BE VERIFIED BY A PROFESSIONAL STRUCTURAL ENGINEER.
- ⑥ LETTER "E" IN MODEL NUMBER DESIGNATES ELECTRIC HEATED UNIT.
- ⑦ DIMENSIONS IN INCHES [CENTIMETERS].

MODEL ①	NOZZLE WIDTH "A"	MOUNTING WIDTH "B"	UNIT WIDTH "C"	ELECTRIC WIDTH "D"
CHC10-1036E	36.00 [91.44]	38.25 [97.16]	39.00 [99.06]	17.00 [43.18]
CHC10-1042E	42.00 [106.68]	44.25 [112.40]	45.00 [114.30]	20.00 [50.80]
CHC10-1048E	48.00 [121.92]	50.25 [127.64]	51.00 [129.54]	23.00 [58.42]
CHC10-1060E	60.00 [152.40]	62.25 [158.12]	63.00 [160.02]	29.00 [73.66]
CHC10-2060E	60.00 [152.40]	62.25 [158.12]	63.00 [160.02]	19.00 [48.26]
CHC10-2072E	72.00 [182.88]	74.25 [188.60]	75.00 [190.50]	17.00 [43.18]
CHC10-2084E	86.88 [220.66]	89.13 [226.38]	89.88 [228.28]	20.75 [52.71]
CHC10-2096E	98.88 [251.14]	101.13 [257.18]	101.88 [258.76]	23.75 [60.33]
CHC10-3096E	98.88 [251.14]	101.13 [257.18]	101.88 [258.76]	15.50 [39.37]
CHC10-2108E	110.88 [281.62]	113.13 [287.38]	113.88 [289.24]	26.75 [67.95]
CHC10-3108E	110.88 [281.62]	113.13 [287.38]	113.88 [289.24]	17.50 [44.45]
CHC10-2120E	116.25 [295.28]	118.50 [300.99]	119.25 [302.90]	28.06 [71.28]
CHC10-3120E	116.25 [295.28]	118.50 [300.99]	119.25 [302.90]	18.38 [46.67]

PROJECT		
LOCATION		
ARCHITECT		
ENGINEER		REV. -
DWG. NO.	CHC10-ELE	TITLE: BERNER
DATE	10NOV14	MODEL CHC10 AIR CURTAIN
BY	SBEL	ELECTRIC HEATED SYSTEM
REPLACES	-	BERNER INTERNATIONAL CORP. NEW CASTLE, PA.
BY	-	