



PAC series

Portable Air-Cooled Spot Cooler

ENGINEERING, INSTALLATION AND SERVICE MANUAL



AIR COOLED



PAC60



PAC12



OCEANAIRE

6228 Oakton Street Morton Grove, IL. 60053
1-866-GET-AIRE (438-2473) Phone: (847) 583-0311 Fax: (847) 583-0312
web-site: www.oceanaire-inc.com e-mail: sales@oceanaire-inc.com

TABLE OF CONTENTS

	PAGE
GENERAL INFORMATION	1
PRODUCT DATA AND SPECIFICATIONS	2
UNIT DESCRIPTION	
Standard Features.....	3
Applications / Operation.....	4
Electrical Configurations.....	5
Use of Extension Cords.....	6
Condensate.....	7
Accessories.....	8 - 14
Inspection/Installation.....	15
Deluxe Electronic Controller.....	16
SERVICE	
Replacement Parts Procedure.....	17
Troubleshooting Guide.....	18
Preventive Maintenance.....	19
Interior View.....	20
DIAGRAMS/SCHEMATICS	
Piping Schematic.....	21
Single Phase Wiring Diagrams.....	22-23
Three Phase Monitor.....	24
Three Phase Wiring Diagrams.....	25 - 28
WARRANTY	29
END USER INFORMATION and TECH NOTES	Back Page

FORWARD

This manual provides the user with basic details for the installation and operation of the OceanAire PAC spot cooler. It is recommended to read and fully understand the instructions outlined within this manual, before operating the PAC unit.

As with all commercial air conditioning equipment, it is recommended to have the PAC sized and installed by a licensed specifying engineer and contractor, in accordance with all local and state codes. The length of service received can be extended by following the installation and preventive maintenance instructions.

NOTICE

In our ongoing process of continuous improvement, the items and procedures described in this manual are subject to change without notice. Please note model and serial number of the PAC unit when contacting the factory.

GENERAL INFORMATION

The OceanAire PAC series is a portable air-cooled spot cooler designed for permanent or temporary cooling applications. The entire air conditioning unit has been built in a premium sheet metal cabinet, equipped with heavy-duty casters for mobility. All PAC models come standard with a 10-foot power cord for electrical connection and added mobility in service. These spot-coolers are designed to direct air to specific areas or objects through a discharge grille located on the upper-front of the unit, while rejecting heat from the top of the unit. The PAC models range in cooling capacities from 12,000 BTU/HR to 60,000 BTU/HR to satisfy most space cooling requirements.

The PAC series is a self-contained unit with the entire cooling system (blower assemblies, electrical and refrigerant components) neatly arranged in a gray polyester powder coated metal cabinet. When connected to the proper source of electrical power, a 24-volt thermostat controls the PAC unit to provide the desired level of comfort and cooling.

A wide variety of accessories and factory installed options are available for the PAC series allowing for improved performance and versatility.

NOMENCLATURE

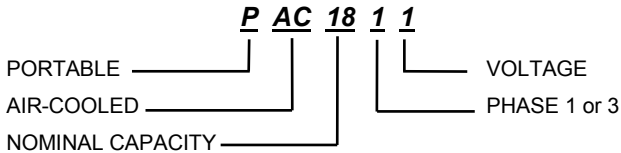

CAPACITY RATING

12.....	12,000 BTU/HR
18.....	18,000 BTU/HR
24.....	24,000 BTU/HR
36.....	36,000 BTU/HR
60.....	60,000 BTU/HR

WARRANTY CARD

It is important that the warranty card be filled out completely and returned to the factory within fourteen (14) days of installation of the unit in order to receive the benefits of the warranty.

SPECIFICATIONS

PAC

MODEL: PAC	1211	1811	2412	3612	3632	3634	6012	6032	6034
Cooling Capacity ²	11,800	16,800	24,020	36,050	36,050	36,050	60,050	60,050	60,050
Voltage (V/Phase) at 60Hz ¹	115/1		208-230/1	208-230/1	208-230/3	460/3	208-230/1	208-230/3	460/3
Amps ⁶	10.4	14.1	14.9	18.1	17.2	8.7	32.0	20.4	14.8
Watts ⁶	1180	1670	2700	3620	3620	3620	6000	6000	6000
In Rush Current (Amps)	60	75	68	113	93	60	178	162	87
Plug Type	5-15P	5-20P	6-20P	6-30P	L15-30P	L16-20P	6-50P	L15-30P	L16-20P
EER ⁴	10.0	10.0	8.9	10.0	10.0	10.0	10.0	10.0	10.0
Compressor HP	1	1 1/2	2	3	3	3	5	5	5
Compressor RLA	9.5	12.3	10.5	13.6	8.8	5.0	27.6	18.1	9.0
Compressor LRA	50	63	48	83	77	35	158	137	62
Evap CFM ³	400	600	810	1200	1200	1200	1950	1950	1950
Evap Motor HP	1/8	1/8	1/3	1/3	1/3	1/3	1	1	1
Evap Motor Watts	180	210	330	375	375	375	550	550	550
Condenser CFM ³	580	930	1010	1390	1390	1390	2200	2200	2200
Condenser Motor HP	1/8	1/8	1/3	1	1	1	1	1	1
Condenser Motor Watts	200	280	350	460	460	460	750	750	750
Condensate	5 Gallon Condensate Tank - STANDARD (Pump Optional)						Pump -STANDARD (20 ft. Lift)		
Sound Level ⁵	54	60	65		69			78	
R-410A Charge Oz.	18	40	37		66			80	
(A) Height with Casters (in.)	36 1/2	45 1/2		50-1/4			51-1/2		
(B) Width (in.)	20	23		27-1/2					
(C) Depth (in.)	25	30			35			39-1/2	
(D) Height w/o Casters (in.)	32 1/2	40 1/2			45			45-1/2	
Net Weight (lb.)	180	260	260	365		380	485	485	515
Shipping Weight (lb.)	200	285	285	405		420	525	525	555
Shipping Volume (cu. ft.)	19	28			40			48	

SPECIFICATIONS SUBJECT TO CHANGE WITHOUT NOTICE

NOTES

1. Dedicated Circuit and Time Delay fuse or circuit breaker are recommended
2. Cooling Capacity is total BTU/H at 80°DB/67° WB return air, 95° DB Condenser Air
3. CFM with free discharge
4. Cooling EER is determined at high fan speed, with condenser air ducted into another area
5. Sound Pressure, dB at 5 feet, commercial operation
6. Amps & Watts at 208 Volts (208-230 V Models)

COOLING AMBIENT*

* May COOL down to 55° if equipped with hot gas bypass (factory installed)

OPERATING RANGE 65° TO 105°

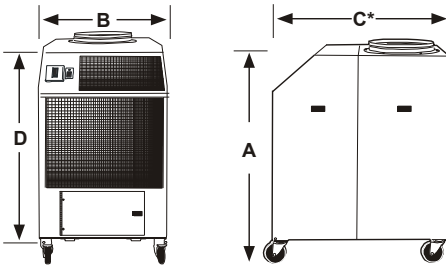

* CONDENSER PLENUM ALLOWANCES

For Size 12, 18 and 24 Models, add 13 inches to Dim C
 For Size 36 and 60 Models, add 17 inches to Dim C

NOT APPROVED FOR OUTDOOR USE

WARRANTY

ALL OCEANAIRE PRODUCTS ARE COVERED BY THE OCEANAIRE LIMITED WARRANTY

1 YEAR ON THE FULL PRODUCT
 PLUS, 4 ADDITIONAL YEARS FOR THE COMPRESSOR
 (RESTRICTIONS APPLY)



STANDARD FEATURES

CABINET

The PAC series cabinet is constructed of 18 gauge steel with a gray polyester powder coated finish that will compliment any decor. The entire cabinet is insulated with sound- absorbing insulation for cool, quiet comfort. All units come equipped with handles and swivel casters for portability and convenient set-up.

ELECTRONIC THERMOSTAT

All PAC units are equipped with a non-programmable electronic thermostat. When power is connected to the unit, the thermostat will control the unit to cool a space to the desired temperature. The thermostat is also capable of controlling the fan to operate automatically when needed, or continuously. To protect the compressor from short-cycling, there is a built-in time delay.

FAN SPEED CONTROL

A two position rocker switch, located next to the thermostat, provides the user with the option of running the evaporator fan at high-speed or low-speed.

CONDENSATE TANK/PUMP

PAC series units come equipped with a means for handling the condensate generated during the cooling process. All units, **except the PAC60 models**, come equipped with a condensate tank. The tank can be easily removed from the unit and emptied as needed.

The PAC60 models come equipped with an Automatic Condensate Pump that removes the condensate. The pump comes with a 20 foot long vinyl hose that allows for the removal of the condensate water to a drain. The automatic pump is capable of a 20ft vertical lift, to handle various installation requirements.

CONDENSATE ALARM LIGHT

On the front of all PAC models, there is a Condensate Alarm Light (RED) located near the thermostat. For models other than PAC60, the light indicates that the condensate tank is full, and needs to be emptied. PAC60 units, the light indicates a condensate pump over-flow condition where the pump is either disabled or restricted, and cannot remove the condensate water, and must be serviced.

FILTERS

All PAC series units are equipped with washable filters at the air intakes. Electrostatic mesh air filter located behind the evaporator return air grille serves to filter the air before it is cooled. A 1/2" aluminum mesh filter serves to protect the condenser coil from dust build-up. Both filters can be easily removed and cleaned.

HIGH PRESSURE SAFETY SWITCH

Located on the back of the PAC unit is a manual re-set high pressure switch, used for the protection of the compressor. If the condensing pressure exceeds the limit setting, the switch will cycle the compressor off, while the evaporator fan remains running. The compressor can be re-started, once the condensing pressure has equalized, by depressing the "RESET" button.

POWER CORDS

All PAC units come standard with a power cord for a convenient connection. All models, except for the 3-phase units and 5-ton units, are equipped with a LCDI for added safety features.

APPLICATIONS

COOLING MODE—SPOT COOLER

The PAC can be used in an open environment to cool specific objects or "spots". Spot Cooling is a convenient and economical way to provide air conditioning, where cooling the entire space is impractical. Cool air is discharged from the unit and is directed where it is needed. Nozzle kits can be used for directional cooling.

AREA COOLER

When the PAC is installed in an open area, the condenser exhaust duct directs the warm air away from the space, allowing the evaporator air to cool the specific area.

ROOM AIR CONDITIONER

When ducted properly, the PAC can be used as a room air conditioner to cool an enclosed space. Using the condenser return air plenum, additional ceiling kit, and other accessories, the PAC can then operate as a room air conditioner with the condenser air isolated from the conditioned space.

PAC SERIES—OPERATION / DESCRIPTION

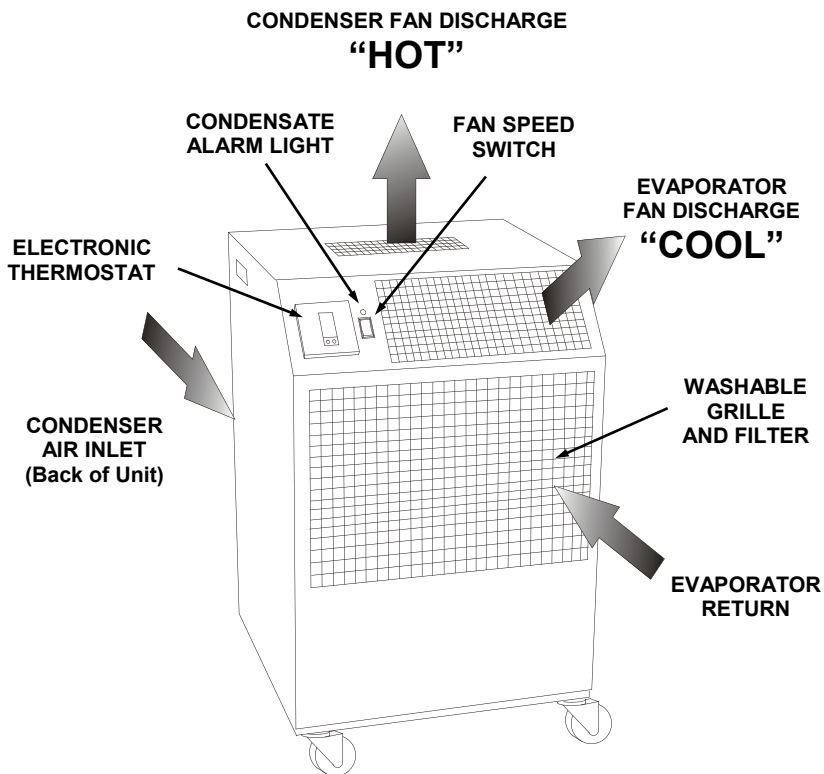

ELECTRICAL CONFIGURATION







SERVICE CORD

All PAC series units are equipped with a standard 10-foot long service cord with plug configurations and receptacle requirements as shown in this chart. PAC1211, PAC1811, PAC2412 and PAC3612 units come with LCDI (Leakage Current Detection & Interruption) devices that serve as a means of electrical protection.

CAUTION—DO NOT USE THE LCDI AS AN ON/OFF SWITCH FOR THE UNIT

All 3-phase models are equipped with locking plugs for added connection reliability. Refer to the chart below for plug and receptacle details for all PAC models.

A DAMAGED LCDI POWER SUPPLY CORD MUST BE REPLACED WITH A NEW POWER SUPPLY CORD OBTAINED FROM OCEANAIRE, AND NOT REPAIRED

UNIT/MODEL	PLUG CONFIGURATION	RECEPTACLE
<u>115 VOLT</u> PAC1211	 15A-125 VOLT NEMA 5-15P	NEMA 5-15R
<u>115 VOLT</u> PAC1811	 20A-125 VOLT NEMA 5-20P	NEMA 5-20R
<u>208-230 VOLT SINGLE PHASE</u> PAC2412	 20A-250 VOLT NEMA 6-20P	NEMA 6-20R
<u>208-230 VOLT SINGLE PHASE</u> PAC3612	 30A-250 VOLT NEMA 6-30P	NEMA 6-30R
<u>208-230 VOLT SINGLE PHASE</u> PAC6012	 50A-250 VOLT NEMA 6-50P	NEMA 6-50R
<u>208-230 VOLT 3-PHASE</u> PAC3632 PAC6032	 30A-250 VOLT NEMA L15-30P	NEMA L15-30R
<u>460 VOLT 3-PHASE</u> PAC3634 PAC6034	 20A-460 VOLT NEMA L16-20P	NEMA L16-20R

USE OF EXTENSION CORDS

CAUTION

FOR MODEL PAC1211 AN EXTENSION CORD CAN BE USED, PROVIDED IT IS RATED AT LEAST 15 AMPS @ 115 VOLTS WITH GROUNDING-TYPE ATTACHMENT PLUG AND GROUNDING TYPE CONNECTOR (LOAD FITTING)

FOR MODEL PAC1811 AN EXTENSION CORD CAN BE USED, PROVIDED IT IS RATED AT LEAST 20 AMPS @ 115 VOLTS WITH GROUNDING-TYPE ATTACHMENT PLUG AND GROUNDING TYPE CONNECTOR (LOAD FITTING)

FOR MODEL PAC2412 AN EXTENSION CORD CAN BE USED, PROVIDED IT IS RATED AT LEAST 20 AMPS @ 250 VOLTS WITH GROUNDING-TYPE ATTACHMENT PLUG AND GROUNDING TYPE CONNECTOR (LOAD FITTING)

FOR MODEL PAC3612 AN EXTENSION CORD CAN BE USED, PROVIDED IT IS RATED AT LEAST 30 AMPS @ 250 VOLTS WITH GROUNDING-TYPE ATTACHMENT PLUG AND GROUNDING TYPE CONNECTOR (LOAD FITTING)

FOR MODEL PAC6012 AN EXTENSION CORD CAN BE USED, PROVIDED IT IS RATED AT LEAST 50 AMPS @ 250 VOLTS WITH GROUNDING-TYPE ATTACHMENT PLUG AND GROUNDING TYPE CONNECTOR (LOAD FITTING)

FOR MODELS PAC3632 AND PAC6032 AN EXTENSION CORD CAN BE USED, PROVIDED IT IS RATED AT LEAST 30 AMPS @ 250 VOLTS, 3 PHASE

FOR MODELS PAC3634 AND PAC6034 AN EXTENSION CORD CAN BE USED, PROVIDED IT IS RATED AT LEAST 20 AMPS @ 600 VOLTS, 3 PHASE

SPECIAL NOTICE—THREE PHASE OPERATION

Models PAC3632, PAC3634, PAC6032 and PAC6034

All three-phase PAC models are equipped with a three-phase monitor for added compressor protection. The phase monitor, located in the control box, has a multi-color LED that reports status. The monitor protects the compressor from reverse operation, phase loss, and low voltage situations. Further description of the three-phase monitor is located in the electrical section of this manual.

NOTICE - DO NOT OPERATE ANY THREE-PHASE UNIT WHILE BYPASSING THE MONITOR. THIS WILL VOID THE WARRANTY.

CONDENSATE

For Models PAC1211, PAC1811, PAC2412, AND PAC3612, a 5-gallon polyethylene tank is provided to collect condensate. The tank is located in the lower front section of the unit, and can be accessed through the condensate tank door. When the high water level is reached, a cut-out switch will AUTOMATICALLY cycle off the compressor/condenser fan.

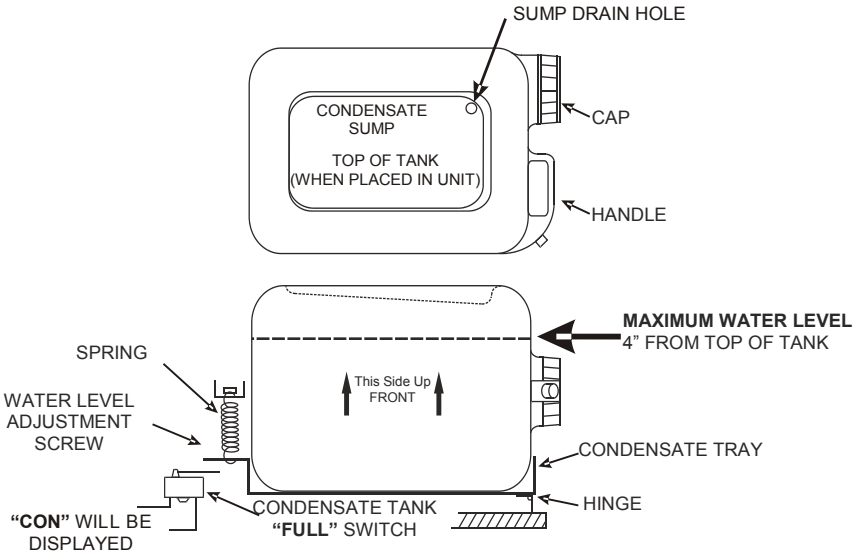

TANK LEVEL ADJUSTMENT INSTRUCTIONS

An adjustment screw is provided to vary the cut-off level of the tank full switch. If less water is desired, turn the adjusting screw clockwise (**CW**).

CAUTION

UNPLUG UNIT BEFORE REMOVING TANK TO ADJUST THE SET SCREW.

Turning the screw clockwise (CW**), will make the tank easier to remove.**

**MAXIMUM WATER LEVEL
4" FROM TOP OF TANK**

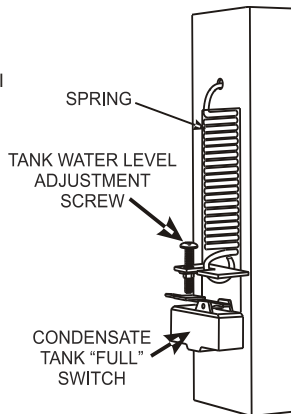

PAC ACCESSORIES

NOTE - IT IS IMPORTANT TO SPECIFY MODEL NUMBER AND SERIAL NUMBER WHEN ORDERING ACCESSORIES

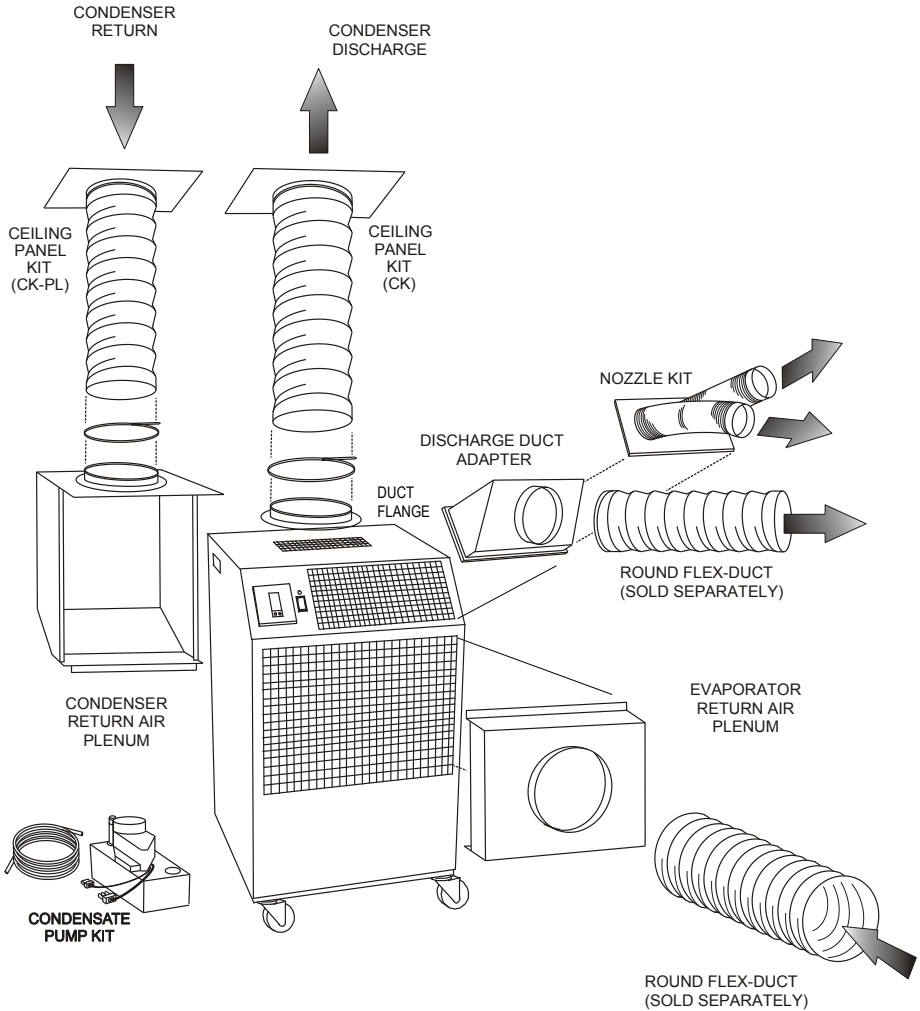

*NOTE: PAC36 and PAC60 come with 16" duct flanges.

PAC SERIES ACCESSORIES

NOZZLE KIT

2NK-1	(2 X 4-Inch)	PAC12
2NK-2	(2 X 6-Inch)	PAC18, 24
2NK-3	(2 X 8-Inch)	PAC36, 60



EVAPORATOR RETURN AIR PLENUM

DEP-10	(10-Inch Round)	PAC12
2DEP-12	(12-Inch Round)	PAC18, 24
DEP-16	(16-Inch Round)	PAC36, 60



DISCHARGE DUCT ADAPTER

2DDA-6	(6-Inch Round)	PAC12
2DDA-10	(10-Inch Round)	PAC18, 24
2DDA-16	(16-Inch Round)	PAC36, 60



CONDENSATE PUMP KIT *

PC-1P	115V Models
PC-2P	230V Models

* Not Required for PAC60's



CEILING PANEL KIT

(Includes Panel, Duct, Strap and Flange)

CK-12	Kit for PAC12, 18, 24
CK-16	Kit for PAC36, 60
CK-12PL	CK-12 without Duct Flange
CKP-12	2 X 2 Ceiling Panel only
CKP-16	2 X 2 Ceiling Panel only



DUCT FLANGE

DF-12	12-Inch Duct Flange
DF-16	16-Inch Duct Flange

NOTE: PAC36 and PAC60 units come with 16" duct flanges installed.



CONDENSER RETURN AIR PLENUM

2DPC-1	(12-Inch Round)	PAC12
2DCP-2	(12-inch Round)	PAC18, 24
DPC-5	(16-Inch Round)	PAC36, 60



ACCESSORIES

CEILING PANEL DUCT KIT

A ceiling panel kit is available for discharging the condenser air above a drop ceiling. The ceiling panel duct kits are furnished with a white vinyl coated flexible duct that allows for convenient installation. A 2ft X 2ft ceiling duct-panel is included to replace a 2ft X 2ft drop-ceiling panel where the connection is desired.

The **CK-12** is available for PAC12, 18, and 24. The ceiling panel kit consists of 8 feet of flexible duct, a 2' X 2' lay in ceiling panel and a 12 inch duct flange that attaches to the condenser air discharge opening on the top of the unit. The **CK-16** (for 3 and 5-ton units) consists of a ceiling duct-panel, and a 16 inch flexible duct.

Note—Drop ceiling spaces should be vented or large enough to handle the warm condenser air. Check local codes to assure compliance.

If longer runs of duct are required, table below lists maximum duct run with no bends. For every 90° elbow, subtract 6 feet from the run.

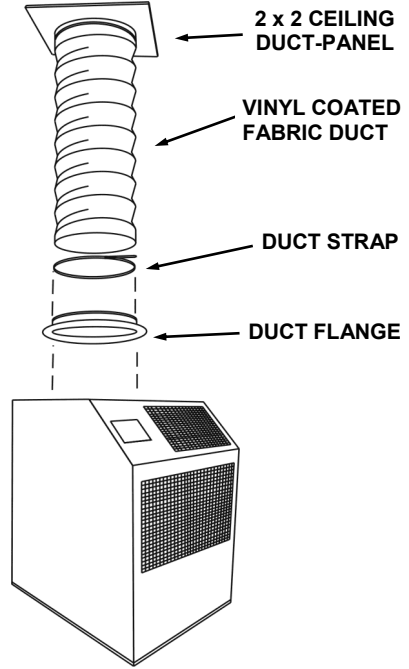

Ceiling Kit Model	Flexible Duct Diameter X Length	Fits PAC12	Fits PAC18	Fits PAC24	Fits PAC36	Fits PAC60
CK-12	12 inch X 8 feet	✓	✓	✓	No	No
CK-16	16 Inch X 8 feet	No	No	No	✓	✓
Maximum Equivalent Feet (approx) (ESP)		25 (.20)	50 (.25)	50 (.25)	50 (.25)	100 (.50)

DUCT FLANGE

The optional duct flange allows for round flexible ducting to be attached to the PAC condenser discharge. **DF-12** (12-inch diameter) fits all units except the 3 ton/5 ton. The **DF-16** (16 inch diameter) fits the 3 ton model PAC36, and 5 ton Model PAC60.

NOTE: PAC36 and PAC60 units come with duct flange installed.



ACCESSORIES

DISCHARGE AIR NOZZLE KIT ASSEMBLY

The optional discharge nozzle kits are used to direct the conditioned air to a specific target area. By concentrating the airflow, the nozzles increase the air velocity towards production lines to cool personnel and/or equipment. In server rooms, the nozzles can be used to direct the airflow through the rack to remove the hot air from the area of the equipment.

2NK-1 for model PAC12, (2) 4-inch diameter nozzles with an approximate compressed length of 15 inches. The approximate extended length is 21 inches.

2NK-2 for models PAC18, PAC24 (2) 6-inch diameter nozzles with an approximate compressed length of 22 inches. The approximate extended length is 32 inches.

2NK-3 for models PAC36 and PAC60, (2) 8-inch diameter nozzles with an approximate compressed length of 20 inches. The extended length is approximately 29 inches.

The nozzle kits come pre-assembled with the nozzles secured to a mounting plate and with edge guards. By removing the discharge grille, you can insert the nozzle kit into the opening without the use of tools.



Nozzle Kits



CONDENSATE PUMP KIT

A plug-in condensate pump kit is available for applications where emptying the 5 gallon condensate tank is not practical. The pump kit consists of a condensate pump with mounting hardware and electrical connections, along with the tubing required for the drain and discharge of the condensate water.



The condensate pump provides for the automatic removal of condensate water during the cooling process. The pump is capable of pumping to a 20 foot height, allowing for the routing of the drain line above the drop-ceiling to a nearby drain. The pump is controlled by an internal float-switch/check valve, which turns the pump on and off automatically. The pump is also equipped with a condensate over-flow safety switch that will shut down the unit compressor when the pump is not working properly.

PARTS LIST

- (1) Condensate Pump with mounting hardware**
- (1) 3/8-inch drain hose, 20 ft**
- (2) Mounting screws**
- (1) Drain hose — black corrugated**
- (2) Hose clamps**

<u>Kit</u>	<u>Voltage</u>
PC-1P	115V
PC-2P	208-230V

Plug-in kit is for models with serial number G4 or higher (Oct. 2003 or later).

ACCESSORIES

CONDENSER RETURN AIR PLENUM

Condenser return air plenums are available for installations where it is required to duct air to the inlet of the condenser. The plenum easily fits into place on the back of the unit, and is provided with a flange for connecting 12-inch or 16-inch flexible ducting. A condenser return air plenum can substantially reduce air noise and allow the unit to operate without drawing condenser air from the conditioned space. Refer to the table below for configuration and application information.

NOTE — *When installing the condenser return air plenum with a ceiling panel kit, allow for a minimum separation distance of 2 feet between the unit discharge duct and the return air duct. It is also recommended to direct the condenser discharge air away from the condenser return air duct.*



2DCP-1, 2DCP-2 and DCP-5

To estimate the “equivalent feet” of condenser duct, add the length of the condenser intake duct run and the length of the condenser discharge duct run, and add 6 equivalent feet per bend in the duct. Make sure that you do not exceed the rated E.S.P. to avoid shut down due to the high pressure cut-out

Plenum Kit	Duct/Flange	PAC12	PAC18	PAC24	PAC36	PAC60
2DCP-1	12-Inch	✓				
2DCP-2	12-Inch		✓	✓		
DCP-5	16-Inch				✓	✓
Maximum Approximate Equivalent Feet		25	50	50	50	100
Estimated External Static Pressure		(.20)	(.25)	(.25)	(.25)	(.50)

ACCESSORIES

EVAPORATOR RETURN AIR PLENUM

Evaporator return air plenums are available for installations where it is required to duct air to the inlet of the evaporator. The evaporator return air plenums allow the user to connect round ducts (flexible or rigid) to the return air intake to reduce air noise and increase the number of options for solving difficult cooling problems. The plenum attaches to the front of the unit, replacing the return air grille. Refer to the table below for configuration and application information

DEP-10 for PAC12 transitions the return air opening to 10-inch round duct.

2DEP-12 for PAC18 and PAC24 transitions the return opening to a 12-inch round duct.

DEP-16 for PAC36 and PAC60 transitions the return opening to a 16-inch round duct.

NOTE—When a DEP is installed, it is recommended to set the evaporator blower speed to high, to avoid evaporator coil freeze-up.

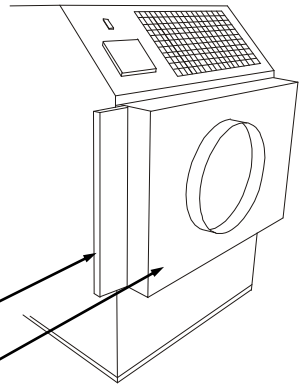

FILTER(S)

DEP—EVAPORATOR
RETURN AIR PLENUM

Plenum Kit Duct/ Flange	PAC12	PAC18	PAC24	PAC36	PAC60	FILTERS
DEP-10 10 inch	✓					(1) 10"X20"X1"
2DEP-12 12 inch		✓	✓			(1) 16"X24"X1"
DEP-16 16 inch				✓	✓	(1) 10"X30"X1" (1) 15"X30"X1"
Maximum Equivalent Feet	25	50	50	50	100	
Est. External Static Pressure	(.20)	(.25)	(.25)	(.25)	(.50)	

ACCESSORIES

DISCHARGE DUCT ADAPTER

Discharge duct adapters are available for applications where ducted evaporator discharge is required. The adapters can be easily installed on the unit without fasteners, and be installed for either vertical or horizontal ducting. The standard discharge grille is removed and the DDA is attached in the grille opening.

2DDA-6 for PAC1211, converts the evaporator discharge to a 6-inch diameter round duct.

2DDA-10 for PAC1811 and PAC2412, converts the evaporator to a 10-inch diameter round duct.

2DDA-16 for PAC36 and PAC60 models, converts the evaporator discharge to a 16-inch round duct.

When used in conjunction with the evaporator return air plenum, DEP/2DEP, the unit can provide closed-loop cooling to and from a given space without the influence of any outside air.



Adapter Model	Round Duct Size	PAC12	PAC18	PAC24	PAC36	PAC60
2DDA-6	6-inch	✓				
2DDA-10	10-inch		✓	✓		
2DDA-16	16-inch				✓	✓
Maximum Equivalent Feet		25	50	50	50	100
Maximum E.S.P		(.15)	(.25)	(.25)	(.25)	(.50)

INSTALLATION INSTRUCTIONS

RECEIVING—INSPECTION

Upon receiving your PAC unit, inspect the packaging for any damage. All units are shipped on a skid, and packaged in a triple-wall carton for added protection.

BEFORE INSTALLING

Check the unit for any damage. All OceanAire products are thoroughly inspected at the factory and carefully packaged. If any damage is evident, contact OceanAire **IMMEDIATELY**.

ELECTRICAL REQUIREMENTS

Check the nameplate located on the back of the unit to confirm the proper power is available for the unit. **Refer to "Specifications"** section for voltage and amperage requirements. For proper NEMA receptacles, refer to "Electrical service plug configuration". When using extension cords, use the proper gauge cord, and check cord voltage to the unit.

TIME DELAY FUSES/CIRCUIT BREAKERS ARE RECOMMENDED

WARNING—OPERATING THE UNIT ON IMPROPER VOLTAGE WILL VOID THE WARRANTY

ACCESSORIES

Verify that all accessories are correct for the model, and are installed in accordance with all instructions.

START-UP

Install the unit in accordance with all local and state building codes, and install all accessories. Allow for a clearance around the unit for future maintenance and/or service. Level unit and lock casters, when available. Connect power and test the LCDI on the power cord (if available). Power up unit, via thermostat and check for proper operation. Refer to Thermostat Operation for more details.

THERMOSTAT OPERATION

FAN

When the power is connected, the LCD screen on the thermostat will illuminate. Pressing the FAN button once will turn on the evaporator fan blower. To turn the blower off, push the FAN button again.

COOLING MODE *

To operate unit for cooling, push **MODE** button to display **COOL** in the window.

Push down arrow button multiple times to lower set point to desired temperature.

The display will show the set-point temperature for 5 seconds. Then it will return to room temperature display.

After a slight pause, both fan motors and compressor will start, beginning the cooling cycle.

Remember, the set-point must be lower than the room temperature for the unit to start.

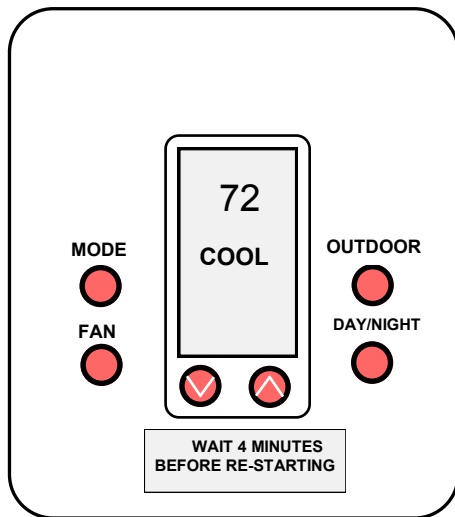

The OUTDOOR and DAY/NIGHT buttons are not used and do not affect unit operation.

This is a cooling only thermostat. Select the temperature you want by pressing the ▲ or ▼ buttons. The word COOL and the temperature set-point is displayed for 5 seconds.

To change display to Celsius, simultaneously press the ▲ and ▼ buttons. Press them again to change back to Fahrenheit.

No batteries are required. In the event of a power failure, when the power is restored the thermostat will continue operating as if the power had never been off.

Compressor short cycle protection is built-in to the thermostat. A time delay will protect the unit.

REPLACEMENT PROCEDURE FOR PARTS

IT IS RECOMMENDED THAT ALL OCEANAIRE UNITS BE SERVICED BY A QUALIFIED AIR CONDITIONING SERVICE TECHNICIAN

WARNING—TO AVOID INJURY, DISCONNECT UNIT POWER PRIOR TO SERVICING

A. FAN MOTORS

1. Remove cabinet left-side panel (when looking at the front of the unit).
2. Evaporator fan motor—disconnect evaporator motor wires from evaporator fan contactor and fan speed rocker switch. Condenser fan motor—disconnect condenser motor wires from condenser fan contactor.
3. **For all model sizes 12, 18, 24, and 36**, remove the screws securing motors and inlet-ring to blower housings (all screws are external and visible), and remove blower wheel-motor assembly. Remove the blower wheel set screw and disassemble the blower wheel from the motor shaft and remove the motor.
For model size 60 loosen blower wheel shaft set screw, remove the screws securing the motor mount to the blower housing and then remove motor and mount. Remove the motor from the motor mount.
4. Install the new motor, reversing the removal procedure.

B. THERMOSTAT (NO BATTERIES REQUIRED)

1. Pull up from the bottom of the thermostat to remove it from the mounting sub-base, by gently prying up on the face plate in the slot at the base of the thermostat. Make sure small thermistor located in the bottom of the thermostat for temperature sensing is not bent or damaged.
2. To remove the thermostat sub-base, remove the 2 mounting screws and the 3 wires (red/yellow/green or red/white/black). Make sure the 3 wires do not fall into the cabinet. Install sub-base by reversing removal procedure.

C. TANK FULL LIGHT

1. To replace the Condensate Alarm Light on all models, disconnect the wires from the lamp and bend the tinnerman clip retaining light and pull out.
2. Install new light, reversing the procedure.

D. CONDENSATE PUMP (ON ALL PAC60 UNITS, OR ON UNITS WHERE THE CONDENSATE PUMP KIT HAS BEEN INSTALLED)

1. Open panel door to allow access for condensate pump service.
2. Remove brackets securing condensate pump in base pan, or condensate tank tray pan.
3. Disconnect pump wire leads at Molex connectors. Remove retainer clamp and tubing.
4. Replace pump, install by reversing procedure.

E. HIGH PRESSURE SAFETY SWITCH

1. Remove cabinet left hand side panel, or left rear side panel of size 60 models.
2. Remove flare nut that secures capillary to the refrigeration system high pressure side. A Schrader valve is located in the discharge port, and allows removal without losing the refrigerant charge.
3. Remove two screws that secure high pressure switch.
4. Disconnect wire leads from compressor contactor and condensate pump safety switch.
5. Install new High Pressure Control, reversing the procedure.

To gain access to compressor and compressor run capacitor, remove left hand side panel.

TROUBLESHOOTING GUIDE

The following steps and procedures are recommended for correcting the problems indicated. In the event that the problem can not be corrected, service may be required.

SERVICE SHOULD BE PERFORMED BY A QUALIFIED AIR CONDITIONING SERVICE TECHNICIAN

PROBLEM: UNIT DOES NOT POWER UP

CAUSE: Power interruption

REMEDY: Check LCDI (on models with LCDI), and reset LCDI. Check external power supply making sure that the disconnect is ON. Check for blown fuses or tripped circuit breakers. Reset or replace if needed.

PROBLEM: NO DISPLAY ON THERMOSTAT

CAUSE: Faulty thermostat or faulty transformer

REMEDY: Thermostat may be defective...remove and replace. Transformer may be defective...remove and replace.

PROBLEM: EVAPORATOR FAN RUNS BUT COMPRESSOR AND CONDENSER FAN DO NOT START

CAUSE: Thermostat — setting may be too high.

REMEDY: Make sure set-point is lower than room temperature. You should see a snowflake "❄" designating that the thermostat is calling for cooling.

Note—there is a time delay for the compressor

CAUSE: Thermostat—Loose wiring

REMEDY: Examine the control unit for loose wires. Tighten any loose connections.

CAUSE: Condensate Alarm—Check for Condensate Alarm Light.

REMEDY: Check condensate level and empty tank if needed, or (if installed) check condensate pump and make sure pump is working properly. Confirm that there is no restriction in the drain line from the pump.

CAUSE: High Pressure Cut-out—Check High Pressure Cut-out Switch.

REMEDY: Press Reset and clear away any air flow obstructions to the condenser intake or condenser discharge.

CAUSE: Voltage — Check power supply for voltage outside the range of 106-126 volts on the 115 Volt unit and 187-253 Volts on the 208/230 Volt unit.

REMEDY: Have power checked by electrician and repaired.

CAUSE: Compressor contactor open or burned.

REMEDY: Replace contactor.

PREVENTIVE MAINTENANCE

PAC series Spot Coolers are designed to last a long time, and to give maximum performance and reliability with minimum maintenance. To prolong the life of the unit, regular maintenance must be performed as specified below:

BLOWER MOTORS

The motors on all units have permanently lubricated bearings. No oiling is necessary

FILTERS

A clogged filter will cause the unit to operate at greatly reduced efficiencies. We recommend that the filter be inspected on a regular basis, **every six weeks or less**, depending on the environment. The evaporator filter is located behind the return air grille, and can be easily removed and cleaned. The condenser filter is located on the backside of the unit. The filters must be washed periodically as needed by placing them in a dishwasher, or soaking them in a solution of warm water and detergent for 10 minutes. Then rinsing them clean with hot water and shaking excess moisture from filter.

CONDENSATE PUMP

Condensate pumps come standard on all size 60 models, and may be installed as options on size 12, 18, 24 and 36 models. When servicing pump follow these steps:

1. Make certain that the unit is disconnected from the power source before attempting to service or remove any component.
2. Be sure the floats move freely. Clean as necessary.
3. Remove the pump housing and check for obstructions. Clean as needed.
4. Clean the housing with warm water and mild soap when mineral deposits are visible.
5. Check the inlet and outlet piping. Clean as necessary. Be sure there are no restriction in the lines that would reduce/obstruct flow.

GENERAL

When necessary maintenance steps outlined above are followed, the air conditioner will provide long and reliable service. The refrigeration and electrical circuits of the system should only be serviced by a fully qualified service technician.

PAC SERIES INTERIOR

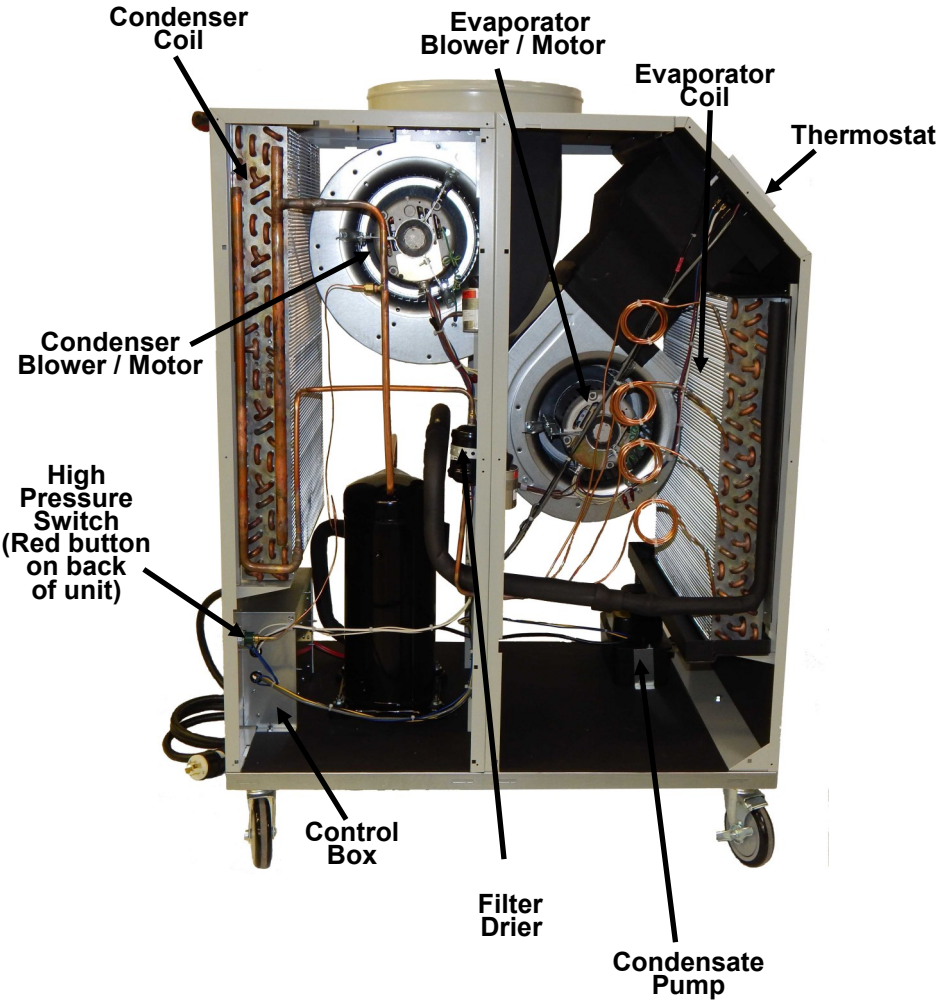

PAC6012 INTERIOR

PIPING SCHEMATIC

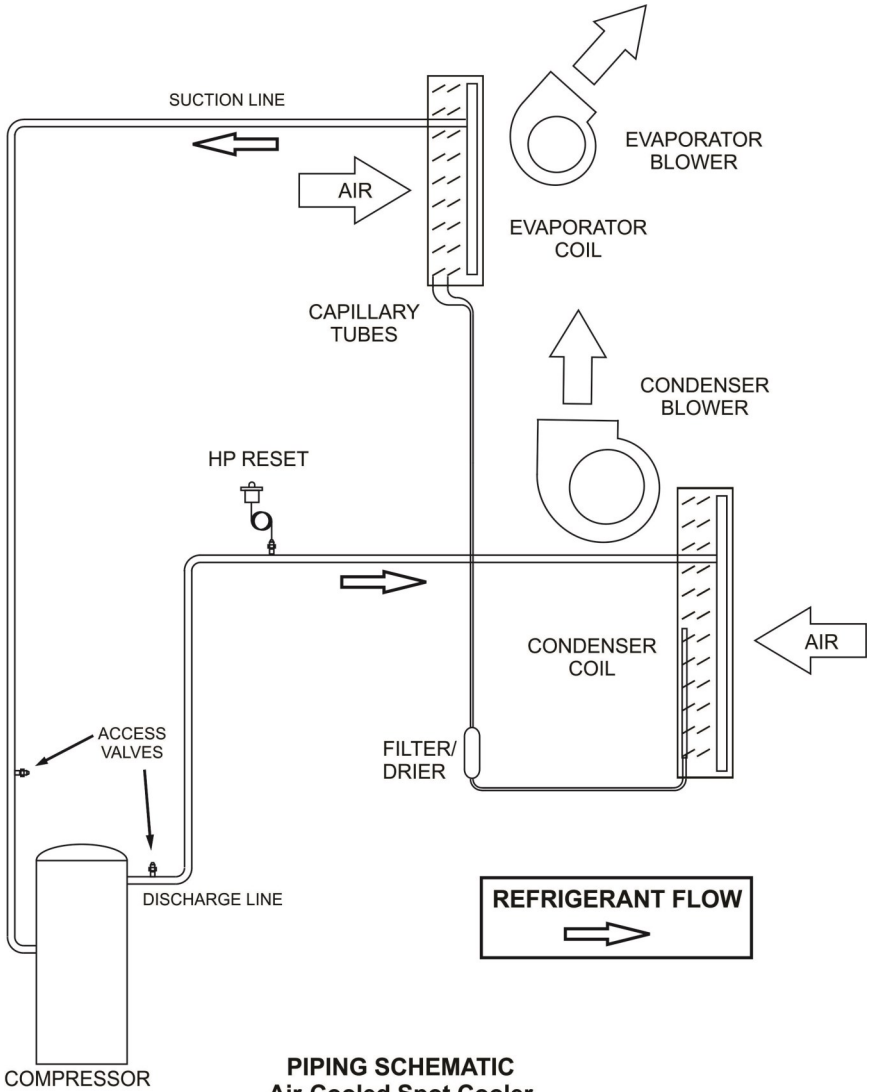

WIRING SCHEMATIC FOR PAC1211, PAC1811, PAC2412, and PAC3612

OCEANAIRE

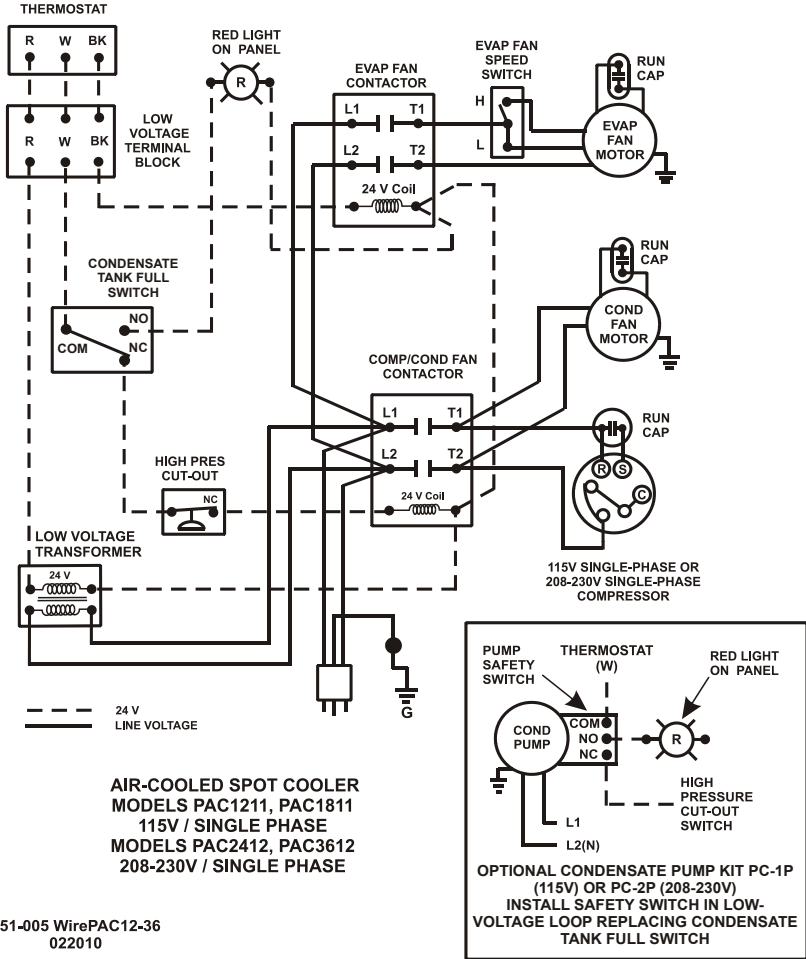

WIRING SCHEMATIC FOR PAC6012

OCEANAIRE

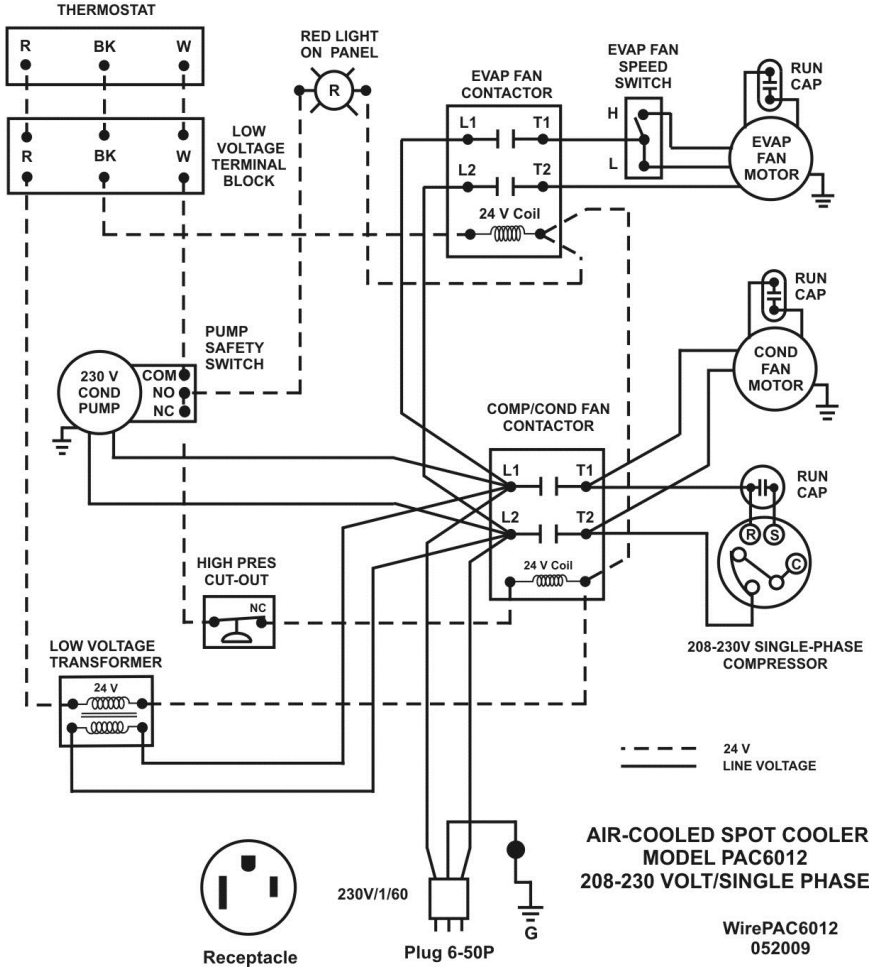

THREE PHASE MONITOR

Three-Phase units are equipped with monitors for motor protection. The Oceanaire Three-phase Monitor safeguards the unit against incorrect compressor rotation, low-voltage and/or loss of power in any one of the power legs. The monitor is installed in the control box and is equipped with an LED for diagnosis of an improper electrical condition (see diagrams below). When power is connected, the compressor **WILL NOT** engage until the monitor start delay has timed out. If the thermostat does not power up, an electrical condition may need to be addressed. Remove the control box cover and observe the LED on the phase monitor. The LED signals the following:

GREEN-BLINKING - Start delay, 120 sec.

GREEN - Proper Operation

RED/GREEN-BLINKING - signals reverse phase rotation. Switch any two of the power leads for the unit, **NOT THE MONITOR LEADS**, and re-start.

RED-BLINKING - signals improper voltage and/or phase loss. Correct the power problem, then re-start the unit.

In the event of a power interruption, the unit will re-set to a start-up condition. The Phase Monitor will not allow the unit to start until power is corrected.

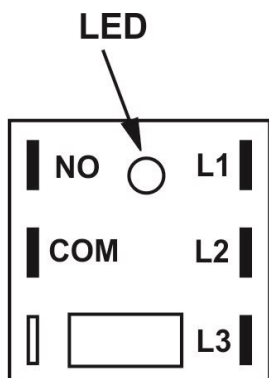

**THREE-PHASE
MONITOR**

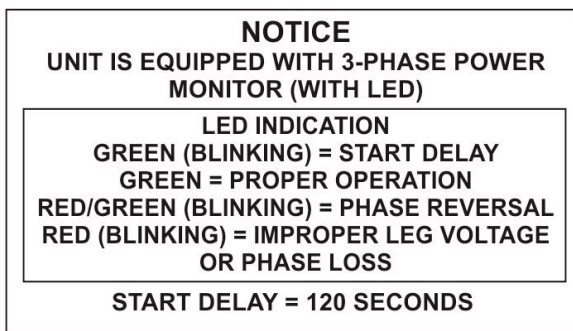

CONTROL BOX LABEL

WIRING SCHEMATIC FOR PAC3632

OCEANAIRE

www.oceanaire-inc.com

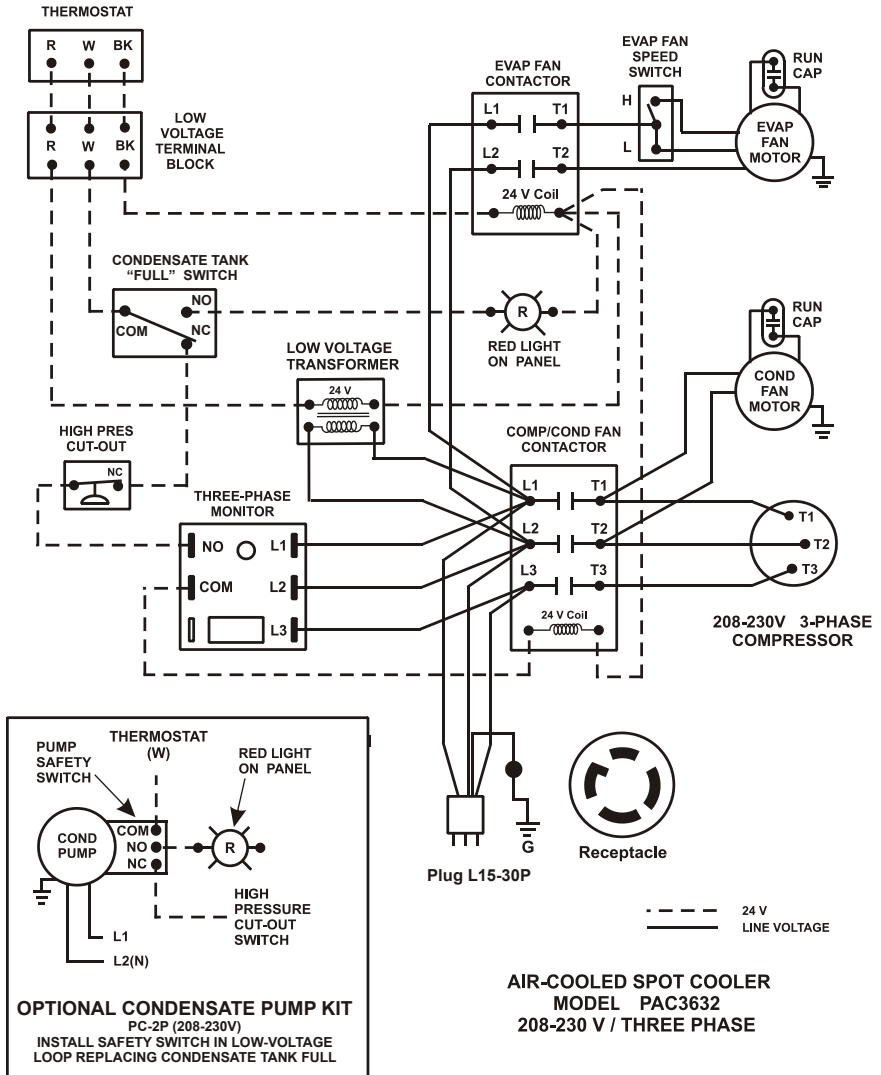

WIRING SCHEMATIC FOR PAC3634

OCEANAIRE
www.oceanaire-inc.com

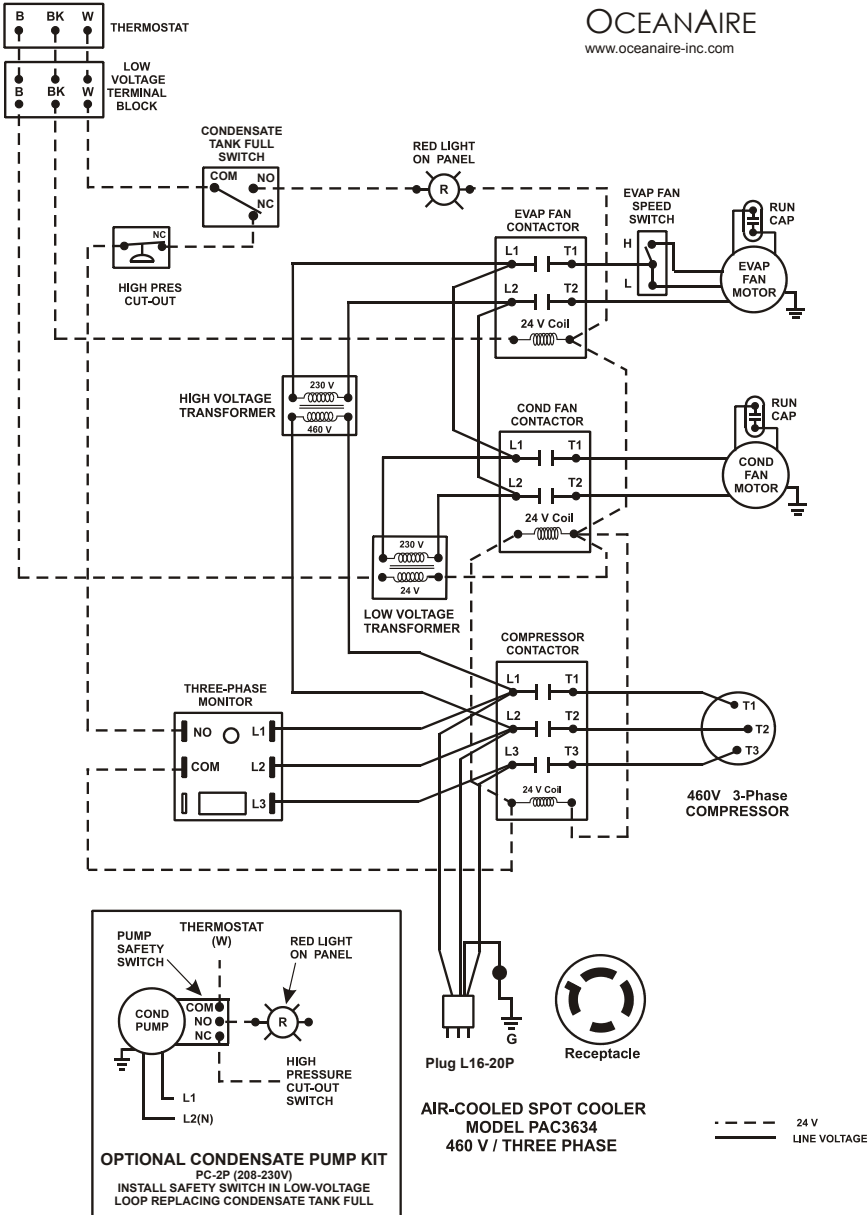

WIRING SCHEMATIC FOR PAC6032

OCEANAIRE
www.oceanaire-inc.com

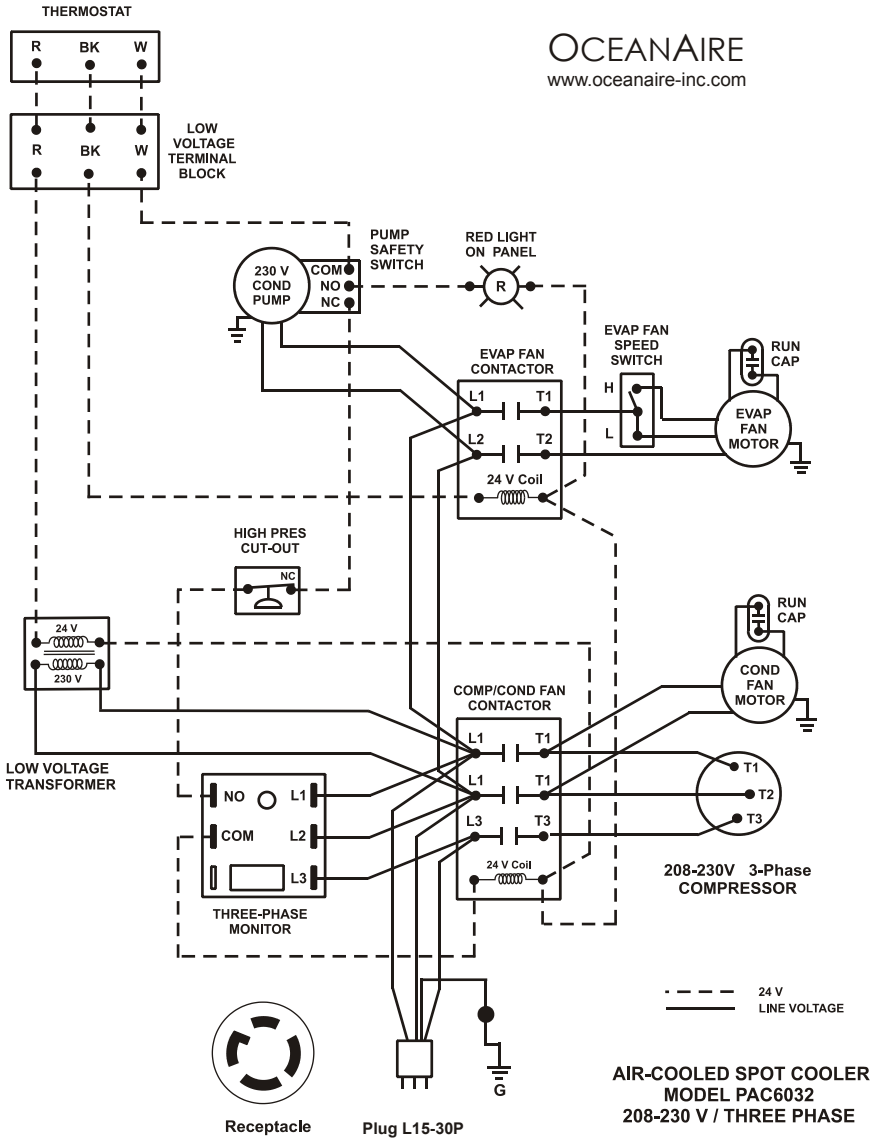

WIRING SCHEMATIC FOR PAC6034

OCEANAIRE
www.oceanaire-inc.com

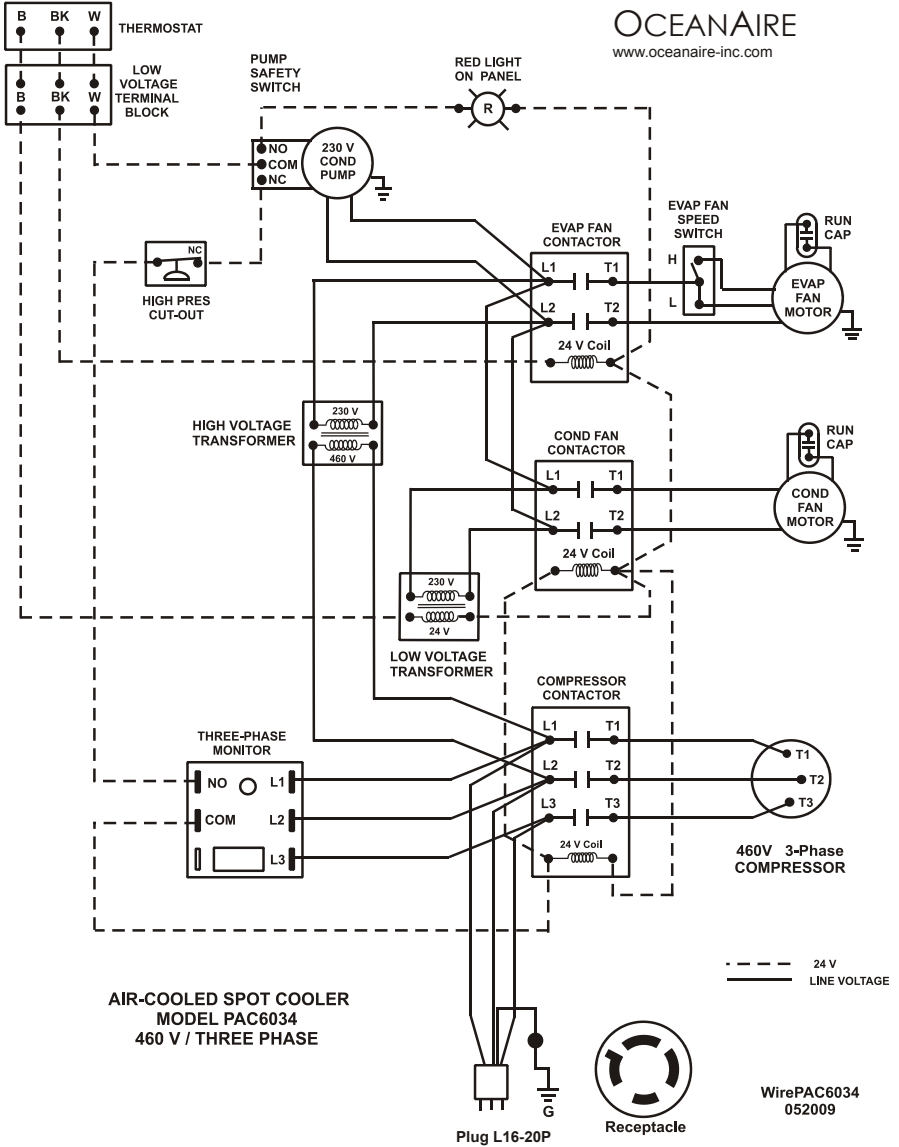

LIMITED WARRANTY

The Manufacturer (Oceanaire, Inc.) warrants to the original owner that the Product will be free from defects in material or workmanship for a period not to exceed one (1) year from date of installation. If upon examination by the Manufacturer, the Product is shown to have a defect in material or workmanship during the warranty period, the Manufacturer will repair or replace, at its option, that part of the Product which is shown to be defective.

The Manufacturer further warrants that the product's compressor-motor will be free from defects in materials and workmanship for five (5) years from the date of installation.

If upon examination by the Manufacturer the Product is shown to have a defect in materials or workmanship during the warranty period, the Manufacturer will repair or replace, at its option, that Part of the Product which is shown to be defective. **Compressor warranty shall be pro-rated for years 2 – 5 at the sole discretion of OceanAire.** Electrical parts such as relays, overloads, capacitors, etc., and the sealed refrigeration system (condenser and evaporator) are included in the one year limited warranty, but not with the five year limited warranty of the compressor.

This limited warranty does not apply to:

- a) Product that has been subjected to misuse or neglect, has been accidentally or intentionally damaged, has not been installed, maintained or operated in accordance with the furnished written instructions, or has been altered or modified in any way.
- b) Product that has been subjected to any abnormal power conditions such as loss of power, power surges, voltage irregularities such as brown-outs or phase loss on three-phase equipment).
- c) any expenses, including labor or material, incurred during removal or reinstallation of the Product.
- d) any workmanship of the installer of the Product.

This limited warranty is conditional upon:

- a) return to the Manufacturer, of the part of the Product thought to be defective.

Goods can only be returned with prior written approval from the Manufacturer.
All returns must be freight prepaid.

- b) determination in the reasonable opinion of the Manufacturer, that there exists a defective in material or workmanship.

Repair or replacement of any part under this Limited Warranty shall not extend the duration of the warranty with respect to such repaired or replaced part beyond the stated warranty period.

THIS LIMITED WARRANTY IS IN LIEU OF ALL OTHER WARRANTIES, EITHER EXPRESSED OR IMPLIED, AND ALL SUCH OTHER WARRANTIES, INCLUDING WITHOUT LIMITATION IMPLIED WARRANTIES OF MERCHANTABILITY OR FITNESS FOR A PARTICULAR PURPOSE, ARE HEREBY DISCLAIMED AND EXCLUDED FROM THIS LIMITED WARRANTY. IN NO EVENT SHALL THE MANUFACTURER BE LIABLE IN ANY WAY FOR ANY CONSEQUENTIAL, SPECIAL, OR INCIDENTAL DAMAGES OF ANY NATURE WHATSOEVER, OR FOR ANY AMOUNTS IN EXCESS OF THE SELLING PRICE OF THE PRODUCT OR ANY PARTS THEREOF FOUND TO BE DEFECTIVE. THIS LIMITED WARRANTY GIVES THE ORIGINAL OWNER OF THE PRODUCT SPECIFIC LEGAL RIGHTS. YOU MAY ALSO HAVE OTHER RIGHTS WHICH MAY VARY BY EACH JURISDICTION.

END USER INFORMATION

MODEL: _____

SERIAL NUMBER: _____

DATE PURCHASED: _____

INSTALLED BY: _____

DATE INSTALLED: _____

For Technical Support, or to locate a distributor for service parts, contact OceanAire at (847) 583-0311 or 1-866-GETAIRE (438-2473). Please indicate the Model Number and Serial Number of the unit to assure proper information and service parts.

TECH NOTES



OCEANAIRE

6228 Oakton Street Morton Grove, IL. 60053
1-866-GET-AIRE (438-2473) Phone: (847) 583-0311 Fax: (847) 583-0312
web-site: www.oceanair-inc.com e-mail: sales@oceanair-inc.com