

OCEANAIRE

"providing a better climate.....anywhere"

20AC SERIES

Deluxe Portable Air-Cooled Spot Cooler

ENGINEERING, INSTALLATION AND SERVICE MANUAL



AIR COOLED



OCEANAIRE

6228 Oakton Street Morton Grove, IL. 60053
1-866-GET-AIRE (438-2473) Phone: (847) 583-0311 Fax: (847) 583-0312
web-site: www.oceanaire-inc.com e-mail: sales@oceanaire-inc.com

Form EISM-20AC 10032016

TABLE OF CONTENTS

	PAGE
GENERAL INFORMATION	1
PRODUCT DATA AND SPECIFICATIONS	2
UNIT DESCRIPTION	
Standard Features.....	3
Applications / Operation.....	4
Electrical Configurations.....	5
Use of Extension Cords.....	6
Condensate.....	7
Accessories.....	8 - 14
Inspection/Installation.....	15
Deluxe Electronic Controller.....	16-18
SERVICE	
Replacement Parts Procedure.....	19
Troubleshooting Guide.....	20
Preventive Maintenance.....	21
Interior View.....	22
DIAGRAMS/SCHEMATICS	
Piping Schematic.....	23
Single Phase Wiring Diagrams.....	24 - 26
Three Phase Monitor.....	27
Three Phase Wiring Diagrams.....	28 - 31
WARRANTY	32
END USER INFORMATION / TECH NOTES	33

FORWARD

This manual provides the user with basic details for the installation and operation of the OceanAire 2OAC spot cooler. It is recommended to read and fully understand the instructions outlined within this manual, before operating the 2OAC unit.

As with all commercial air conditioning equipment, it is recommended to have the 2OAC sized and installed by a licensed specifying engineer and contractor, in accordance with all local and state codes. The length of service received can be extended by following the installation and preventive maintenance instructions.

NOTICE

In our ongoing process of continuous improvement, the items and procedures described in this manual are subject to change without notice. Please note model and serial number of the 2OAC unit when contacting the factory.

GENERAL INFORMATION

The OceanAire 2OAC is a portable air-cooled spot cooler designed for permanent or temporary spot cooling applications. The entire unit has been built in a premium sheet metal cabinet, equipped with heavy-duty casters for mobility. All 2OAC models come standard with a 10-foot power cord for electrical connection and added mobility in service. These units direct cool air to specific areas or objects through a discharge grille located on the upper-front of the unit, while rejecting heat from the top of the unit. The 2OAC models range in capacities from 12,000 BTU/HR to 60,000 BTU/HR to satisfy most space cooling requirements.

The 2OAC is a self-contained unit with the entire system (evaporator and condenser blower assemblies, electrical and refrigeration components), neatly arranged in a gray and blue polyester powder coated metal cabinet. When connected to the proper source of electrical power, the 2OAC is controlled by a solid-state electronic controller, with numerous options of temperature and airflow controls that will provide the desired level of comfort when cooling.

A wide variety of accessories and factory installed options are available for the 2OAC units allowing for improved performance and added versatility.

NOMENCLATURE

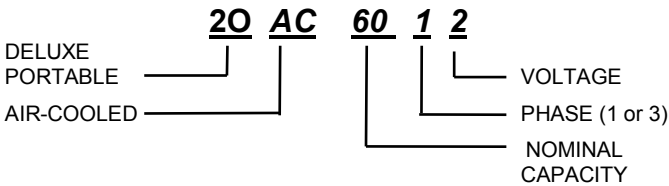

CAPACITY RATING

12.....	12,000 BTU/HR
18.....	18,000 BTU/HR
24.....	24,000 BTU/HR
36.....	36,000 BTU/HR
60.....	60,000 BTU/HR

WARRANTY CARD

It is important that the warranty card be filled out completely and returned to the factory within fourteen (14) days of installation of the unit in order to receive the benefits of the warranty.

SPECIFICATIONS

20AC

MODEL: 20AC	1211	1811	2412	3612	3632	3634	6012	6032	6034
Cooling Capacity ²	11,800	16,800	24,020	36,050	36,050	36,050	60,050	60,050	60,050
Voltage (V/Phase) at 60Hz ¹	115/1		208-230/1	208-230/1	208-230/3	460/3	208-230/1	208-230/3	460/3
Amps ⁶	10.4	14.1	14.9	18.1	17.2	8.7	32.0	20.4	14.8
Watts ⁶	1180	1670	2700	3620	3620	3620	6000	6000	6000
In Rush Current (Amps)	60	75	68	113	93	60	178	162	87
Plug Type	5-15P	5-20P	6-20P	6-30P	L15-30P	L16-20P	6-50P	L15-30P	L16-20P
EER ⁴	10.0	10.0	8.9	10.0	10.0	10.0	10.0	10.0	10.0
Compressor HP	1	1 1/2	2	3	3	3	5	5	5
Compressor RLA	9.5	12.3	10.5	13.6	8.8	5.0	27.6	18.1	9.0
Compressor LRA	50	63	48	83	77	35	158	137	62
Evap CFM ³	400	600	810	1200	1200	1200	1950	1950	1950
Evap Motor HP	1/8	1/8	1/3	1/3	1/3	1/3	1	1	1
Evap Motor Watts	180	210	330	375	375	375	550	550	550
Condenser CFM ³	580	930	1010	1390	1390	1390	2200	2200	2200
Condenser Motor HP	1/8	1/8	1/3	1	1	1	1	1	1
Condenser Motor Watts	200	280	350	460	460	460	750	750	750
Condensate	5 Gallon Condensate Tank - STANDARD (Pump Optional)						Pump -STANDARD (20 ft. Lift)		
Sound Level ⁵	54	60	65	69			78		
R-410A Charge Oz.	18	40	37	66			80		
(A) Height with Casters (in.)	36 1/2	45 1/2		50-1/4			52 1/4		
(B) Width (in.)	20	24		28					
(C) Depth (in.)	25	30		35			39		
(D) Height w/o Casters (in.)	32 1/2	40 1/2		45			46		
Net Weight (lb.)	180	260	260	365		380	485	485	515
Shipping Weight (lb.)	200	285	285	405		420	525	525	555
Shipping Volume (cu. ft.)	19	28		40			48		

SPECIFICATIONS SUBJECT TO CHANGE WITHOUT NOTICE

NOTES

1. Dedicated Circuit and Time Delay fuse or circuit breaker are recommended
2. Cooling Capacity is total BTUH at 80°DB/67° WB return air, 95° DB Condenser Air
3. CFM with free discharge
4. Cooling EER is determined at high fan speed, with condenser air ducted into another area
5. Sound Pressure, dB at 5 feet, commercial operation
6. Amps & Watts at 208 Volts (208-230 V Models)

COOLING AMBIENT*

OPERATING RANGE 65° TO 105°

* May COOL down to 55° if equipped with hot gas bypass (factory installed)

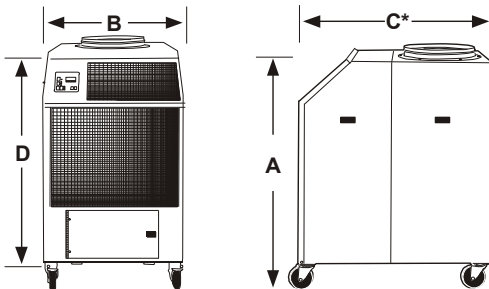

NOT APPROVED FOR OUTDOOR USE

WARRANTY

ALL OCEAIRE PRODUCTS ARE COVERED BY THE OCEAIRE LIMITED WARRANTY

1 YEAR ON THE FULL PRODUCT

PLUS, 4 ADDITIONAL YEARS FOR THE COMPRESSOR (RESTRICTIONS APPLY)

* CONDENSER PLENUM ALLOWANCES

For Size 12, 18 and 24 Models, add 13 inches to Dim C
For Size 36 and 60 Models, add 17 inches to Dim C



AIR COOLED

STANDARD FEATURES

CABINET

The 2OAC Series spot cooler has a cabinet that is constructed of 18 gauge steel with a polyester powder coated finish that will compliment any decor. The cool blue front compliments any surrounding space, and is insulated with sound-absorbing insulation for cool, quiet comfort. All units come equipped with handles and premium swivel casters for portability and convenient set-up.

DELUXE ELECTRONIC CONTROLLER

Each 2OAC unit is equipped with a deluxe electronic controller. When power is connected to the unit, the thermostat will control the unit to cool a space to the desired temperature. The thermostat is also capable of controlling the fan to operate automatically when needed, or continuously.

One additional feature of the Deluxe Electronic Controller is that it will display a condition alarm "CON". "CON" displays when a condensate alarm, or a high pressure reset condition has been met. To protect the compressor from short-cycling, there is a built-in time delay.

FAN SPEED CONTROL

One of the features of the electronic controller is that the unit supply fan can be controlled either automatically or manually. In AUTO mode, the indoor blower will adjust air flow automatically for added comfort and performance. Or, if desired, the controller can be set to MANUAL fan mode, and the indoor blower will run continuously at one of six levels of fan speed.

CONDENSATE TANK/PUMP

2OAC units come equipped with a means for handling the condensate generated during the cooling process. All units, **except the 5-ton models**, come equipped with a condensate tank. The tank can be easily removed from the unit and emptied as needed.

The 2OAC60 models come equipped with an automatic condensate pump. The pump comes with a 20 foot long vinyl hose that allows for the removal of the condensate water to a drain. The automatic pump is capable of a 20ft vertical lift, to handle almost any installation requirement.

FILTERS

All 2OAC units are equipped with washable filters at the air intakes. Electrostatic mesh air filters located behind the evaporator return air grille serve to filter the air before it is cooled, and behind the condenser return air grille to prevent dust build-up. Both filters can be easily removed and cleaned.

HIGH PRESSURE SAFETY SWITCH

Located on the back of the 2OAC unit is a manual re-set high pressure switch, used for the protection of the compressor. If the condensing pressure exceeds the limit setting, the switch will cycle the compressor off, while the evaporator fan remains running. The display will indicate the default setting "CON". The compressor can then be re-started, once the condensing pressure has equalized, by depressing the "RESET" button.

POWER CORDS

All 2OAC units come standard with a power cord for a convenient connection. All models, except for the 3-phase units and 5-ton units, are equipped with a LCDI for added safety features.

APPLICATIONS

COOLING MODE—SPOT COOLER

The 2OAC can be used in an open environment to cool specific objects or "spots". Spot Cooling is a convenient and economical way to provide air conditioning, where cooling the entire space is impractical. Cool air is discharged from the unit and is directed where it is needed. Nozzle kits can be used for directional cooling.

AREA COOLER

When the 2OAC is installed in an open area, the condenser exhaust duct directs the warm air away from the space, allowing the evaporator air to cool the specific area.

ROOM AIR CONDITIONER

When ducted properly, the 2OAC can be used as a room air conditioner to cool an enclosed space. Using the condenser return air plenum, additional ceiling kit, the 2OAC can then operate as a room air conditioner with the condenser air isolated from the conditioned space.

2OAC—COOLING MODE OPERATION / DESCRIPTION

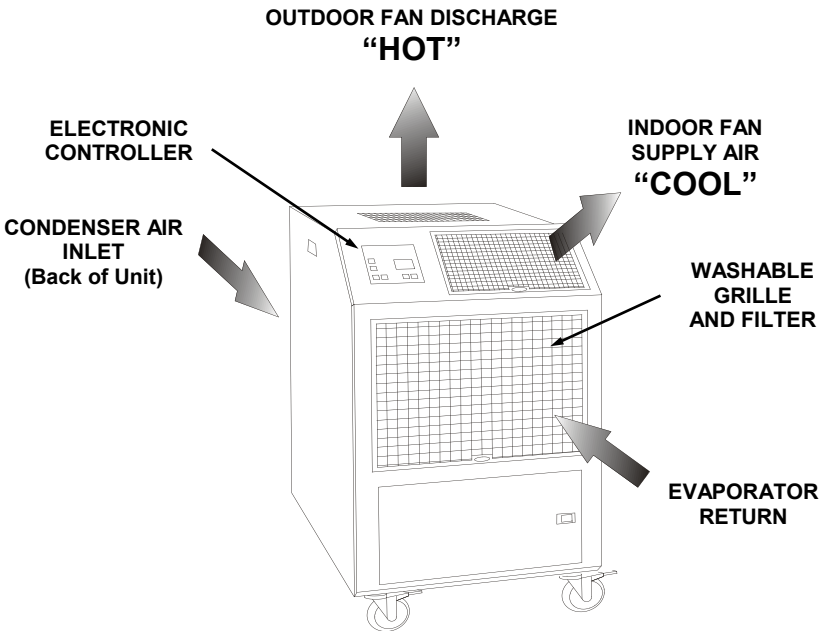

2OAC—COOLING MODE

ELECTRICAL CONFIGURATION







All 2OAC-Series units are equipped with a standard 10-foot long service cord with plug configurations and receptacle requirements as shown in this chart. 2OAC1211, 2OAC1811, 2OAC2412 and 2OAC3612 units come with LCDI (Leakage Current Detection & Interruption) devices that serve as a means of electrical protection.

CAUTION

DO NOT USE THE LCDI AS AN ON/OFF SWITCH FOR THE UNIT

All 3-phase models are equipped with locking plugs for added connection reliability. Refer to the chart below for plug and receptacle details for all 2OAC models.

A DAMAGED LCDI POWER SUPPLY CORD MUST BE REPLACED WITH A NEW POWER SUPPLY CORD AND NOT REPAIRED

UNIT/MODEL	PLUG CONFIGURATION	RECEPTACLE
<u>115 VOLT</u> 2OAC1211	 15A-125 VOLT NEMA 5-15P	NEMA 5-15R
<u>115 VOLT</u> 2OAC1811	 20A-125 VOLT NEMA 5-20P	NEMA 5-20R
<u>208-230 VOLT SINGLE PHASE</u> 2OAC2412	 20A-250 VOLT NEMA 6-20P	NEMA 6-20R
<u>208-230 VOLT SINGLE PHASE</u> 2OAC3612	 30A-250 VOLT NEMA 6-30P	NEMA 6-30R
<u>208-230 VOLT SINGLE PHASE</u> 2OAC6012	 50A-250 VOLT NEMA 6-50P	NEMA 6-50R
<u>208-230 VOLT 3-PHASE</u> 2OAC3632 2OAC6032	 30A-250 VOLT NEMA L15-30P	NEMA L15-30R
<u>460 VOLT 3-PHASE</u> 2OAC3634 2OAC6034	 20A-460 VOLT NEMA L16-20P	NEMA L16-20R

USE OF EXTENSION CORDS

CAUTION

FOR MODEL 2OAC1211 AN EXTENSION CORD CAN BE USED, PROVIDED IT IS RATED AT LEAST 15 AMPS @ 115 VOLTS WITH GROUNDING-TYPE ATTACHMENT PLUG AND GROUNDING TYPE CONNECTOR (LOAD FITTING)

FOR MODEL 2OAC1811 AN EXTENSION CORD CAN BE USED, PROVIDED IT IS RATED AT LEAST 20 AMPS @ 115 VOLTS WITH GROUNDING-TYPE ATTACHMENT PLUG AND GROUNDING TYPE CONNECTOR (LOAD FITTING)

FOR MODEL 2OAC2412 AN EXTENSION CORD CAN BE USED, PROVIDED IT IS RATED AT LEAST 20 AMPS @ 250 VOLTS WITH GROUNDING-TYPE ATTACHMENT PLUG AND GROUNDING TYPE CONNECTOR (LOAD FITTING)

FOR MODEL 2OAC3612 AN EXTENSION CORD CAN BE USED, PROVIDED IT IS RATED AT LEAST 30 AMPS @ 250 VOLTS WITH GROUNDING-TYPE ATTACHMENT PLUG AND GROUNDING TYPE CONNECTOR (LOAD FITTING)

FOR MODEL 2OAC6012 AN EXTENSION CORD CAN BE USED, PROVIDED IT IS RATED AT LEAST 50 AMPS @ 250 VOLTS WITH GROUNDING-TYPE ATTACHMENT PLUG AND GROUNDING TYPE CONNECTOR (LOAD FITTING)

FOR MODELS 2OAC3632 AND 2OAC6032 AN EXTENSION CORD CAN BE USED, PROVIDED IT IS RATED AT LEAST 30 AMPS @ 250 VOLTS, 3 PHASE

FOR MODELS 2OAC3634 AND 2OAC6034 AN EXTENSION CORD CAN BE USED, PROVIDED IT IS RATED AT LEAST 20 AMPS @ 600 VOLTS, 3 PHASE

SPECIAL NOTICE—THREE PHASE OPERATION

Models 2OAC3632, 2OAC3634, 2OAC6032 and 2OAC6034

All three-phase 2OAC models are equipped with a three-phase monitor for added compressor protection. The phase monitor, located in the control box, has a multi-color LED that reports status. The monitor protects the compressor from reverse operation, phase loss, and low voltage situations. Further description of the three-phase monitor is located in the electrical section of this manual.

NOTICE - DO NOT OPERATE ANY THREE-PHASE UNIT WHILE BYPASSING THE MONITOR. THIS WILL VOID THE WARRANTY.

CONDENSATE

For Models 2OAC1211, 2OAC1811, 2OAC24 and 2OAC36, a 5-gallon polyethylene tank is provided to collect condensate. The tank is located in the lower front section of the unit, and can be accessed through the condensate tank door. When the high water level is reached, a cut-off switch will AUTOMATICALLY cycle off the compressor/condenser fan.

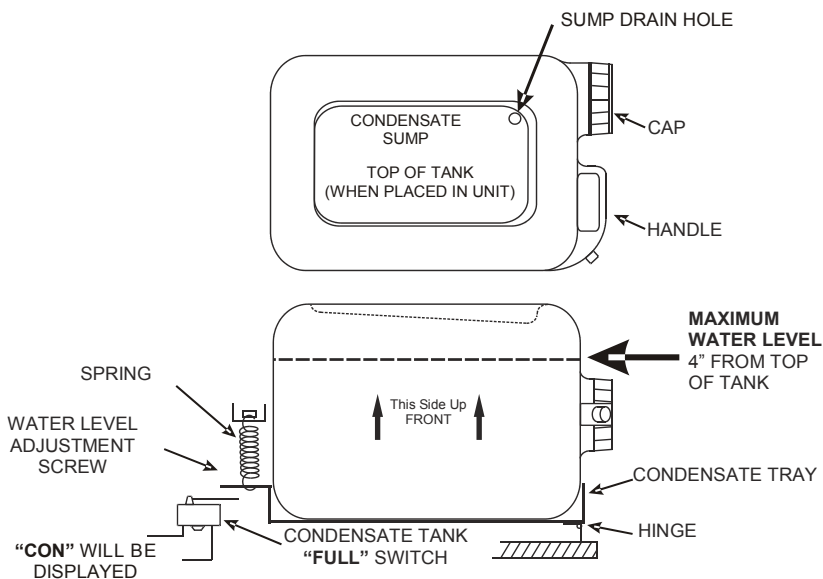

TANK LEVEL ADJUSTMENT INSTRUCTIONS

An adjustment screw is provided to vary the cut-off level of the tank full switch. If less water is desired, turn the adjusting screw clockwise (**CW**).

CAUTION

UNPLUG UNIT BEFORE REMOVING TANK TO ADJUST THE SET SCREW.

Turning the screw clockwise (CW), will make the tank easier to remove.

**MAXIMUM WATER LEVEL
4" FROM TOP OF TANK**

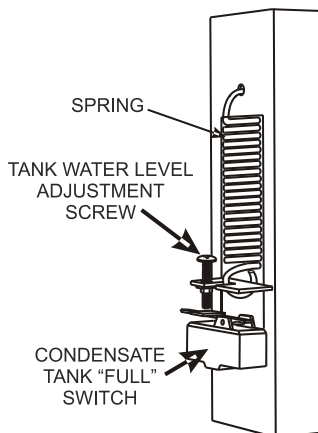

2OAC ACCESSORIES

NOTE - IT IS IMPORTANT TO SPECIFY MODEL NUMBER AND SERIAL NUMBER WHEN ORDERING ACCESSORIES

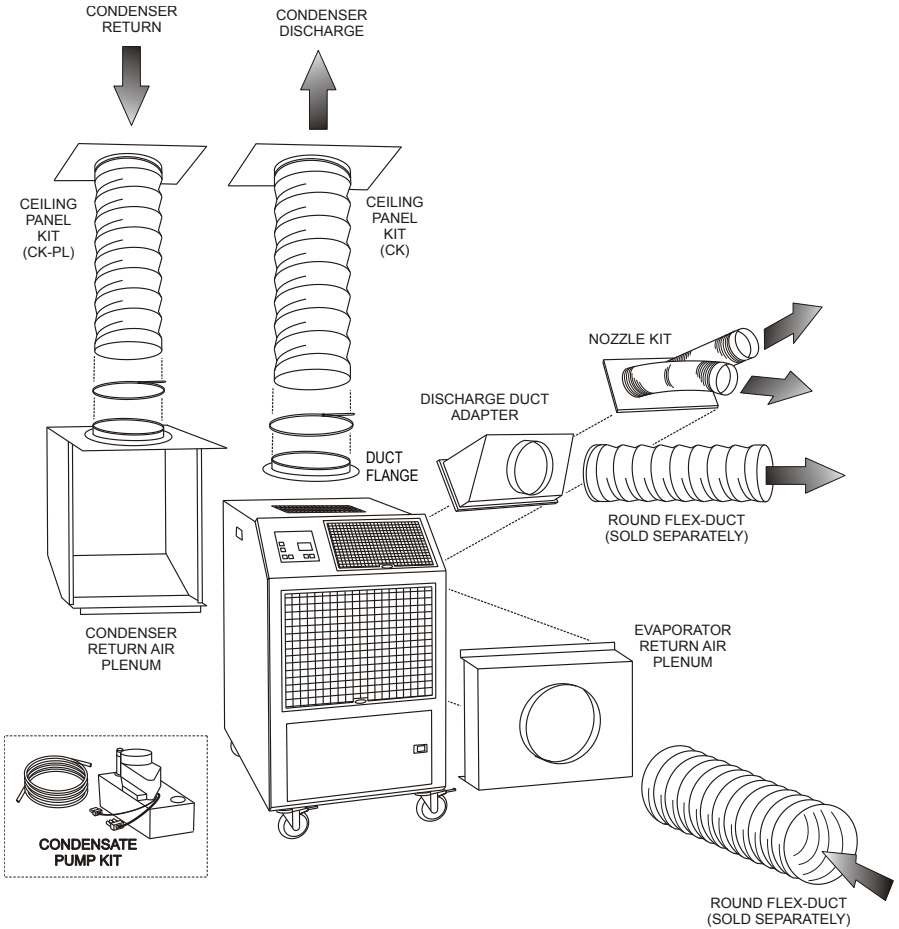

*NOTE: 2OAC36 and 2OAC60 come with 16" duct flanges.

2OAC ACCESSORIES

NOZZLE KIT

2NK-1	(2 X 4-Inch)	2OAC12
2NK-2	(2 X 6-Inch)	2OAC18, 24
2NK-3	(2 X 8-Inch)	2OAC36, 60



EVAPORATOR RETURN AIR PLENUM

DEP-10	(10-Inch Round)	2OAC12
2DEP-12	(12-Inch Round)	2OAC18, 24
DEP-16	(16-Inch Round)	2OAC36, 60



DISCHARGE DUCT ADAPTER

2DDA-6	(6-Inch Round)	2OAC12
2DDA-10	(10-Inch Round)	2OAC18, 24
2DDA-16	(16-Inch Round)	2OAC36, 60



CONDENSATE PUMP KIT *

2DPC-1	115V Models
2DPC-2	230V Models

* Not Required for 2OAC60's



CEILING PANEL KIT

(Includes Panel, Duct, Strap and Flange)

CK-12	Kit for 2OAC12, 18, 24
CK-16	Kit for 2OAC36, 60
CK-12PL	CK-12 without Duct Flange
CKP-12	2 X 2 Ceiling Panel only
CKP-16	2 X 2 Ceiling Panel only



DUCT FLANGE

DF-12	12-Inch Duct Flange
DF-16	16-Inch Duct Flange

NOTE: 2OAC36 and 2OAC60 units come with 16" duct flanges installed.



CONDENSER RETURN AIR PLENUM

2DPC-1	2OAC12
2DCP-2	2OAC18, 24
DCP-5	2OAC36, 60



ACCESSORIES

CEILING PANEL DUCT KIT

A ceiling panel kit is available for discharging the condenser air above a drop ceiling. The ceiling panel duct kits are furnished with a white vinyl coated flexible duct that allows for convenient installation. A 2ft X 2ft ceiling duct- panel is included to replace a 2ft X 2ft drop-ceiling panel where the connection is desired.

The **CK-12** is available for 2OAC12, 18, and 24. The ceiling panel kit consists of 8 feet of flexible duct, a 2' X 2' lay in ceiling panel and a 12 inch duct flange that attaches to the condenser air discharge opening on the top of the unit. The **CK-16** (for 3 and 5-ton units) consists of a ceiling duct-panel, and a 16 inch flexible duct.

Note—Drop ceiling spaces should be vented or large enough to handle the warm condenser air. Check local codes to assure compliance.

If longer runs of duct are required, table below lists maximum duct run with no bends. For every 90° elbow, subtract 6 feet from the run.

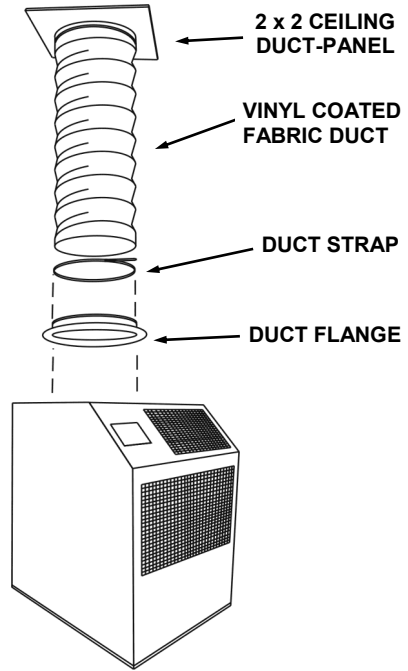

Ceiling Kit Model	Flexible Duct Diameter X Length	Fits 2OAC12	Fits 2OAC18	Fits 2OAC24	Fits 2OAC36	Fits 2OAC60
CK-12	12 inch X 8 feet	✓	✓	✓	No	No
CK-16	16 Inch X 8 feet	No	No	No	✓	✓
Maximum Equivalent Feet (approx) (ESP)		25 (.20)	50 (.25)	50 (.25)	50 (.25)	100 (.50)

DUCT FLANGE

The optional duct flange allows for round flexible ducting to be attached to the 2OAC condenser discharge. **DF-12** (12-inch diameter) fits all units except the 3 ton/5 ton. The **DF-16** (16 inch diameter) fits the 3 ton model 2OAC36, and 5 ton Model 2OAC60.

NOTE: 2OAC36 and 2OAC60 units come with duct flange installed.



ACCESSORIES

DISCHARGE AIR NOZZLE KIT ASSEMBLY

The optional discharge nozzle kits are used to direct the conditioned air to a specific target area. By concentrating the airflow, the nozzles increase the air velocity towards production lines to cool personnel and/or equipment. In server rooms, the nozzles can be used to direct the airflow through the rack, and remove the hot air from the equipment area.

2NK-1 for model 2OAC12, with (2) 4-inch diameter nozzles with an approximate compressed length of 15 inches. The approximate extended length is 21 inches.

2NK-2 for models 2OAC18 and 2OAC24 with (2) 6-inch diameter nozzles with an approximate compressed length of 22 inches. The approximate extended length is 32 inches.

2NK-3 for 2OAC36 and 2OAC60, with (2) 8-inch diameter nozzles with an approximate compressed length of 20 inches. The extended length is approximately 29 inches.

The nozzle kits come pre-assembled with the nozzles secured to a mounting plate, and with edge guards. By removing the 2OAC discharge grille, you can insert the nozzle kit into the opening without the use of tools.



Nozzle Kits

CONDENSATE PUMP KIT

A plug-in condensate pump kit is available for applications where emptying the 5 gallon condensate tank is not practical. The pump kit consists of a condensate pump with mounting hardware and electrical connections, along with the tubing required for the drain and discharge of the condensate water.



The condensate pump provides for the automatic removal of condensate water during the cooling process. The pump is capable of pumping to a 20 foot height, allowing for the routing of the drain line above the drop-ceiling to a nearby drain. The pump is controlled by an internal float-switch/check valve, which turns the pump on and off automatically. The pump is also equipped with a condensate over-flow safety switch, that will cycle the compressor off when the pump is not working properly.

PARTS LIST

- (1) Condensate Pump with mounting hardware
- (1) 3/8-inch drain hose, 20 ft
- (2) Mounting screws
- (1) Drain hose — black corrugated
- (2) Hose clamps

<u>Kit</u>	<u>Voltage</u>
2DPC-1	115V
2DPC-2	208-230V

(2OAC60 models come with pump installed)

ACCESSORIES

CONDENSER RETURN AIR PLENUM

Condenser return air plenums are available for installations where it is required to duct air to the inlet of the condenser. The plenum easily fits into place on the back of the unit, and is provided with a flange for connecting 12-inch or 16-inch flexible ducting. A condenser return air plenum can substantially reduce air noise and allow the unit to operate without drawing condenser air from the conditioned space. Refer to the table below for configuration and application information.

NOTE — When installing the condenser return air plenum with a ceiling panel kit, allow for a minimum separation distance of 2 feet between the unit discharge duct and the return air duct. It is also recommended to direct the condenser discharge air away from the condenser return air duct.



2DPC-1, 2DCP-2, DCP-5

To estimate the “equivalent feet” of condenser duct, add the length of the condenser intake duct run and the length of the condenser discharge duct run, and add 6 equivalent feet per bend in the duct. Make sure that you do not exceed the rated E.S.P. to avoid shut down due to the high pressure cut-out.

Plenum Kit Flange	Duct	20AC12	20AC18	20AC24	20AC36	20AC60
2DCP-1	12-inch	✓				
2DCP-2	12-inch		✓	✓		
DCP-5	16-Inch				✓	✓
Maximum Approximate Equivalent Feet		25	50	50	50	100
Estimated External Static Pressure		(.20)	(.25)	(.25)	(.25)	(.50)

ACCESSORIES

EVAPORATOR RETURN AIR PLENUM

Evaporator return air plenums are available for installations where it is required to duct air to the inlet of the evaporator. The evaporator return air plenums allow the user to connect round duct (flexible or rigid) to the return air intake to reduce air noise and increase the number of options for solving difficult application problems. The plenum attaches to the front of the unit, replacing the return air grille. Refer to the table below for configuration and application information.

DEP-10 for 2OAC12 transitions the return air opening to a 10-inch round duct.

2DEP-12 for 2OAC18 & 2OAC24 transitions the return opening to a 12-inch round duct.

DEP-16 for 2OAC36, 60 transitions the return opening to a 16-inch round duct.

NOTE—When an evaporator return air plenum is installed, it is recommended to set the evaporator blower speed to high, to avoid coil freeze-up.

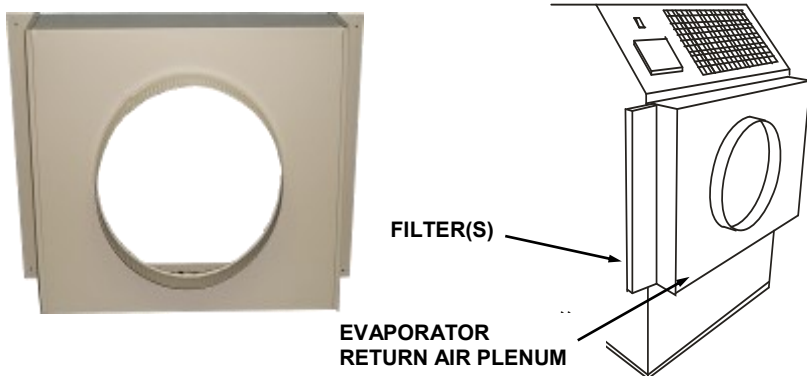

Plenum Kit Duct/ Flange	2OAC12	2OAC18	2OAC24	2OAC36	2OAC60	FILTERS
DEP-10 10 inch	✓					(1) 10"X20"X1"
2DEP-12 12 inch		✓	✓			(1) 16"X24"X1"
DEP-16 16 inch				✓	✓	(1) 10"X30"X1" (1)15"X30"X1"
Maximum Equivalent Feet	25	50	50	50	100	
Estimated External Static Pressure	(.20)	(.25)	(.25)	(.25)	(.50)	

ACCESSORIES

DISCHARGE DUCT ADAPTER

Discharge duct adapters are available for applications where ducted evaporator discharge is required. The adapters can be easily installed on the unit without fasteners, and can be used for either vertical or horizontal ducting. The standard discharge grille is removed and the 2DDA is attached in the grille opening.

2DDA-6 for model 2OAC12, converts the evaporator discharge to a 6-inch diameter round duct.

2DDA-10 for models 2OAC18 and 2OAC24, converts the evaporator discharge to a 10-inch diameter round duct.

2DDA-16 for models 2OAC36 AND 2OAC60, converts the evaporator discharge to a 16-inch round duct.

When used in conjunction with the evaporator return air plenum, the unit can provide a closed-loop cooling solution for a given space without the influence of any outside air.



Adapter Model	Round Duct Size	2OAC12	2OAC18	2OAC24	2OAC36	2OAC60
2DDA-6	6-inch	✓				
2DDA-10	10-inch		✓	✓		
2DDA-16	16-inch				✓	✓
Maximum Approx. Equivalent Feet		25	50	50	50	100
Maximum E.S.P		.15	.25	.25	.25	.50

INSTALLATION INSTRUCTIONS

RECEIVING—INSPECTION

Upon receiving your 2OAC unit, inspect the packaging for any damage. All units are shipped on a skid, and packaged in a triple-wall carton for added protection.

BEFORE INSTALLING

Check the unit for any damage. All OceanAire products are thoroughly inspected at the factory and carefully packaged. If any damage is evident, contact OceanAire **IMMEDIATELY**.

ELECTRICAL REQUIREMENTS

Check the nameplate located on the back of the unit to confirm the proper power is available for the unit. **Refer to "Specifications"** section for voltage and amperage requirements. For proper NEMA receptacles, refer to "Electrical service plug configuration". When using extension cords, use the proper gauge cord, and check cord voltage to the unit.

TIME DELAY FUSES/CIRCUIT BREAKERS ARE RECOMMENDED

WARNING—OPERATING THE UNIT ON IMPROPER VOLTAGE WILL VOID THE WARRANTY

ACCESSORIES

Verify that all accessories are correct for the model, and are installed in accordance with all instructions.

START-UP

Install the unit in accordance with all local and state building codes, and install all accessories. Allow for a clearance around the unit for future maintenance and/or service. Level unit and lock casters, when available. Connect power and test the LCDI on the power cord (if available). Power up unit, via thermostat and check for proper operation. Refer to Thermostat Operation for more details.

DELUXE ELECTRONIC CONTROLLER

The 2OAC controller is equipped with many features for a more precise level of cooling and operation. Additionally, the controller can be removed from the unit and installed for remote operation, if needed (accessory parts may be required).

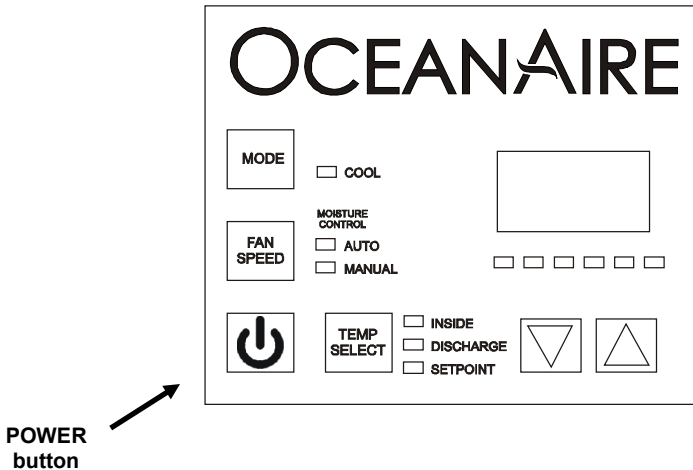

OCEANAIRE DELUXE ELECTRONIC CONTROLLER

When power is connected, the controller will display “888” momentarily, and will then disappear. Press the **POWER** button, then press the **TEMP SELECT** button until the **SET POINT** is displayed. Adjust the **SET POINT** to the desired temperature, and the unit will cool as programmed.

The systems controls temperature within +/- 2°

POWER—Turns the unit on/off when power is supplied

MODE - Select the **Cool** or **Moisture Control**

COOL - The system will operate in **cooling mode, only**

MOISTURE CONTROL - The system operates in the cooling mode to reduce humidity within the conditioned space. Every 4 hours, the fan is started, circulating the air, and the air temperature is recorded by the controller. The cooling cycle is started for one hour, or until the room temperature drops 2°, which ever comes first. This cycle repeats every four hours.

FAN SPEED—The operator can select between **AUTO** or **MANUAL** fan speed control. Pressing the **FAN SPEED** button, will switch speed from **AUTO** to **MANUAL**. In **MANUAL** mode, pressing the **FAN SPEED** button will change fan speed from low to high. In **AUTO** mode, the fan speed is controlled automatically. In cooling mode, the controller automatically adjusts the fan speed to high, and as the inside temperature approaches the set point, the fan speed will reduce.

TEMP SELECT— Allows the operator to view the controller temperatures **INSIDE** = return air temperature, **DISCHARGE** = supply air temperature, **SET POINT** can be seen and adjusted, by pressing **▲** or **▼**.

CONTROLLER PROGRAMMING MENU

- 1) Make sure the unit has power .
- 2) Press the  power button “OFF”.
- 3) Press the following buttons in sequence “**S-U-D-S**”
(Select—Up arrow — Down arrow — Select)
- 4) The display will begin flashing P1 and a number.

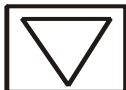

*If there is no display, repeat the sequence,
making sure the unit has power, but is turned OFF.*

- 5) To adjust any program feature, press the **ARROW UP ▲** or **ARROW DOWN ▼** button until the desired value is displayed.
- 6) Use the “**MODE**” button to scroll through the programmable settings P1 through P16.
- 7) If no buttons are pressed, the display will then return to the “**OFF**” position after about 50 seconds.

PROGRAM SETTINGS

- P1—High Fan Speed Limit Setting, 56 - 85**
- P2—Low Fan Speed Limit Setting, 30 - 55**
- P4—Temperature Sensor Calibration, +/- 10°**
- P10— Temperature Display, °F or °C**
- P13—Supply Fan Operation, Cycling or Continuous**
- P15—Fan Motor Type Setting, PSC or Shaded Pole**

P1, P2 - To adjust fan speed settings, **P1** represents the high fan speed parameter, while **P2** represents the low fan speed parameter. When using nozzle kits, discharge duct adapters and evaporator plenums, setting **P1** to 85 will help to avoid freeze ups.

P4 - Adjust the **P4** setting to match the actual **INSIDE** room temperature, if needed.

P10 - Use this parameter to display temperatures in the desired units.

P13 - To cycle the evaporator fan with the compressor, access code **P-13**. Press the up or down button to switch to “**CYC**”, which means cycle the fan with the compressor. The factory default setting is “**CON**”, which means continuous fan operation.

P15 - Fan Motors are PSC type, **SC** - should be selected.

- 8) Press **POWER** — you should see an alphanumeric code.

Press **POWER** and the unit will start at the new settings

2OAC PROGRAM SETTINGS

MODEL	CODE SETTINGS
2OAC12	P1 = 65, P2 = 45
2OAC18	P1 = 80, P2 = 50
2OAC24	P1 = 70, P2 = 50
2OAC36	P1 = 85, P2 = 40
2OAC60	P1 = 85, P2 = 45

NOTICE

**Program Parameters are NOT controller default values.
They are OceanAire Factory Settings**

DISPLAY FAULTS

LAC..... Low AC line power

AAA..... Failed Air Sensor (unit will not run)

CON..... Empty Condensate Bucket—Units with a bucket
Condensate Pump Over-Flow Alarm—Units with pump
High Pressure Cut-Out—Restricted air flow
correct problem, and re-set unit at HP RESET

TO CHECK THE NUMBER OF HOURS ON THE UNIT

- 1) Disconnect unit power, and reconnect unit power.
- 2) When “888” appears in display, push and release the arrow down button



- 3) The first set of numbers displayed reads thousands of hours:
02 = 2000, 04 = 4000 hours, 00 means less than 1000 hours.
- 4) The second set of numbers read hours directly:
58 = 58 hours. 742 = 742 hours.
- 6) Add the 2 number sets together to get total hours.
03 and 486 = 3486 hours. 01 and 59 = 1059 hours.

TOTAL HOURS REPRESENTS COMPRESSOR “RUN” TIME

REPLACEMENT PARTS PROCEDURE

**IT IS RECOMMENDED THAT ALL OCEANAIRE UNITS
BE SERVICED BY A LICENSED TECHNICIAN**

***WARNING—TO AVOID INJURY, DISCONNECT UNIT POWER
PRIOR TO SERVICING***

A. FAN MOTORS

1. Remove cabinet's left-side panel (when looking at the front of the unit).
2. Evaporator fan motor—disconnect evaporator motor wires from evaporator fan contactor and power module. Condenser fan motor—disconnect condenser motor wires from condenser fan contactor.
3. **For all model sizes 12, 18, 24, and 36**, remove the screws securing motors and inlet-ring to blower housings (all screws are external and visible), and remove blower wheel-motor assembly. Remove the blower wheel set screw and disassemble the blower wheel from the motor shaft and remove the motor.
For model size 60—loosen blower wheel shaft set screw, and remove the screws securing the motor mount to the blower housing and remove motor and mount. Remove the motor from the motor mount.
4. Install the new motor, reversing the removal procedure.

B. ELECTRONIC CONTROLLER (THERMOSTAT)

To remove the cooling only display, remove the cabinet's left-side panel (from front). Locate the two nuts securing the display to the front panel. Unplug the display cable and remove display. Install new display and secure. Plug in display cable.

C. POWER MODULE

To remove the power module, remove the rear control box cover. Disconnect wires (one at a time), and re-attach each wire, while holding replacement module in other hand. Once all wires have been reconnected in accordance with the wiring diagram, install new power module.

D. CONDENSATE PUMP (ON ALL 5-TON UNITS, OR ON UNITS WHERE THE CONDENSATE PUMP KIT HAS BEEN INSTALLED)

1. Remove side panel.
2. Remove brackets securing condensate pump in base pan, or condensate tank tray pan
3. Disconnect pump wire leads at Molex connectors. Remove retainer clamp and tubing.
4. Replace pump, install by reversing procedure.

E. HIGH PRESSURE SAFETY SWITCH

1. Remove cabinets right side panel, or right rear side panel of Model 60.
2. Remove flare nut that secures capillary to the refrigeration system high pressure side. A schrader valve is located in the discharge port which allows removal without losing the refrigerant charge.
3. Remove two screws that secure high pressure switch.
4. Disconnect wire leads from compressor contactor and condensate pump safety switch.
5. Install new High Pressure Control, reversing the procedure.

To gain access to compressor and compressor run capacitor, remove left hand side panel.

TROUBLESHOOTING GUIDE

The following steps and procedures are recommended for correcting the problems indicated. In the event that the problem can not be corrected, service may be required.

SERVICE SHOULD BE PERFORMED BY A QUALIFIED AIR CONDITIONING SERVICE TECHNICIAN

PROBLEM: UNIT DOES NOT POWER UP

CAUSE: Power interruption

REMEDY: Check LCDI (on models with LCDI), and reset LCDI. Check external power supply making sure that the disconnect is ON. Check for blown fuses or tripped circuit breakers. Reset or replace if needed.

CAUSE: Loose display cable

REMEDY: Re-seat display cable at display and power module.

CAUSE: Phase Monitor Fault (3-Phase Models)

REMEDY: Check Phase Monitor, and correct power problem.

PROBLEM: EVAPORATOR FAN RUNS, BUT COMPRESSOR AND CONDENSER FAN DO NOT START

CAUSE: SET POINT — setting may be too high for cooling .

REMEDY: Make sure set-point is adjusted accordingly. You should see a red dot to the right of the temperature display indicating compressor ON.

Note—there is a time delay for the compressor

CAUSE: Loose Display Cable

REMEDY: Examine the control unit for loose wires. Tighten any loose connections.

CAUSE: Condition Alarm "CON".

REMEDY: Check condensate tank and empty tank or check condensate pump and make sure pump is working properly and that there is no kink in the drain line from the pump.

CAUSE: High Pressure Cut-Out "CON" Check High Pressure Cut-out Switch.

REMEDY: Press Reset and clear away any obstructions to the condenser intake or condenser discharge.

CAUSE: Compressor contactor open or burned.

REMEDY: Replace contactor

CAUSE: Defective Power Module

REMEDY: Replace Power Module.

PREVENTIVE MAINTENANCE

2OAC Spot Coolers are designed to last a long time and to give maximum performance and reliability with minimum maintenance. To prolong the life of the unit, regular maintenance must be performed as specified below:

BLOWER MOTORS

The motors on all units have permanently lubricated bearings. No oiling is necessary

FILTERS

A clogged filter will cause the unit to operate at greatly reduced efficiencies. We recommend that the filter be inspected on a regular basis **every six weeks or less**, depending on the environment. The evaporator filter is located behind the return air grille and can be easily removed and cleaned. The condenser filter is located on the lower backside of the unit. The filters must be washed periodically as needed by placing them in a dishwasher or soaking them in a solution of warm water and detergent for 10 minutes. Then rinsing them clean with hot water and shaking excess moisture from filter.

CONDENSATE PUMP

Condensate pumps come standard on all Size 60 models, and may be installed as an accessory on size 12, 18, 24 and 36 models. When servicing pump follow these steps;

1. Make certain that the unit is disconnected from the power source before attempting to service or remove any component.
2. Be sure the floats move freely. Clean as necessary.
3. Remove the pump housing and check for obstructions. Clean as needed.
4. Clean the housing with warm water and mild soap when mineral deposits are visible.
5. Check the inlet and outlet piping. Clean as necessary. Be sure there are no kinks in the lines that would restrict flow.

GENERAL

When necessary maintenance steps outlined above are followed, the air conditioner will provide long and reliable service. The refrigeration and electrical circuits of the system should only be serviced by a fully qualified service technician.

2OAC12 INTERIOR VIEW

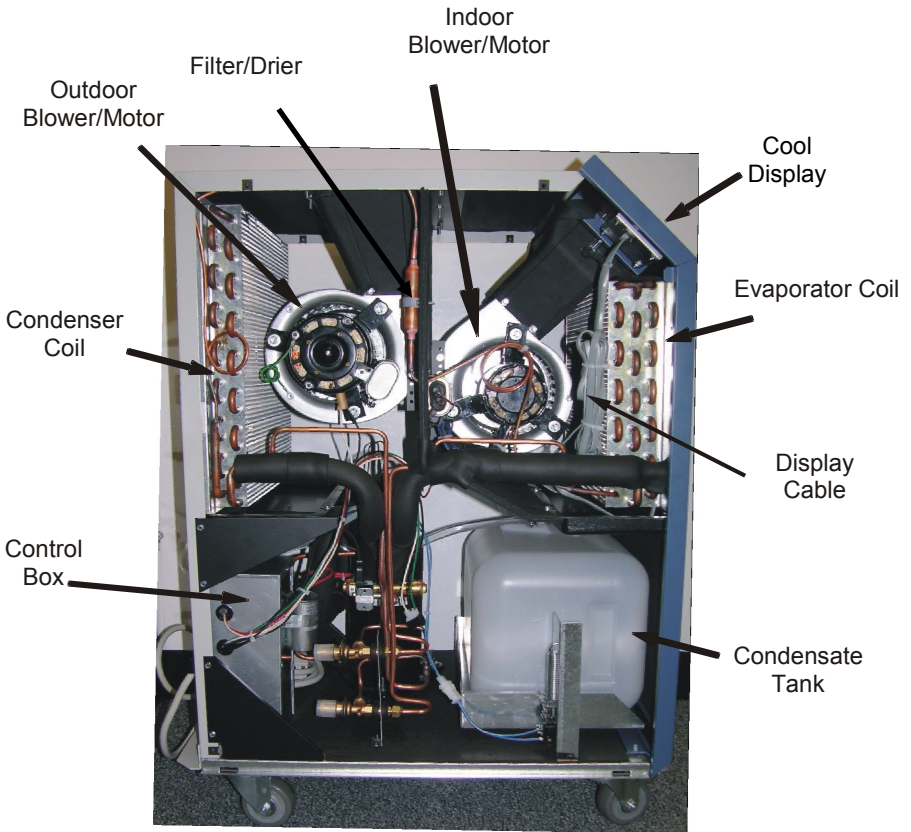

PIPING SCHEMATIC

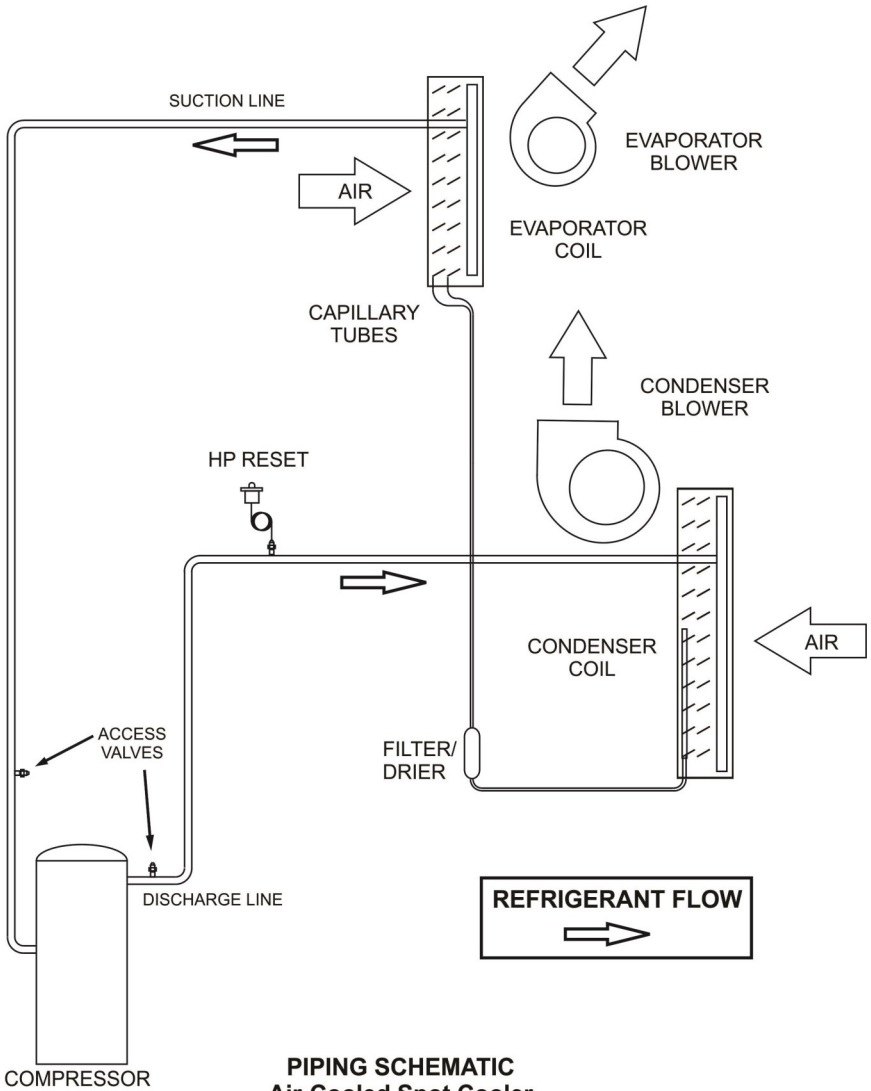

PIPING SCHEMATIC
Air-Cooled Spot Cooler

WIRING SCHEMATIC FOR 20AC1211, 1811 and 2412

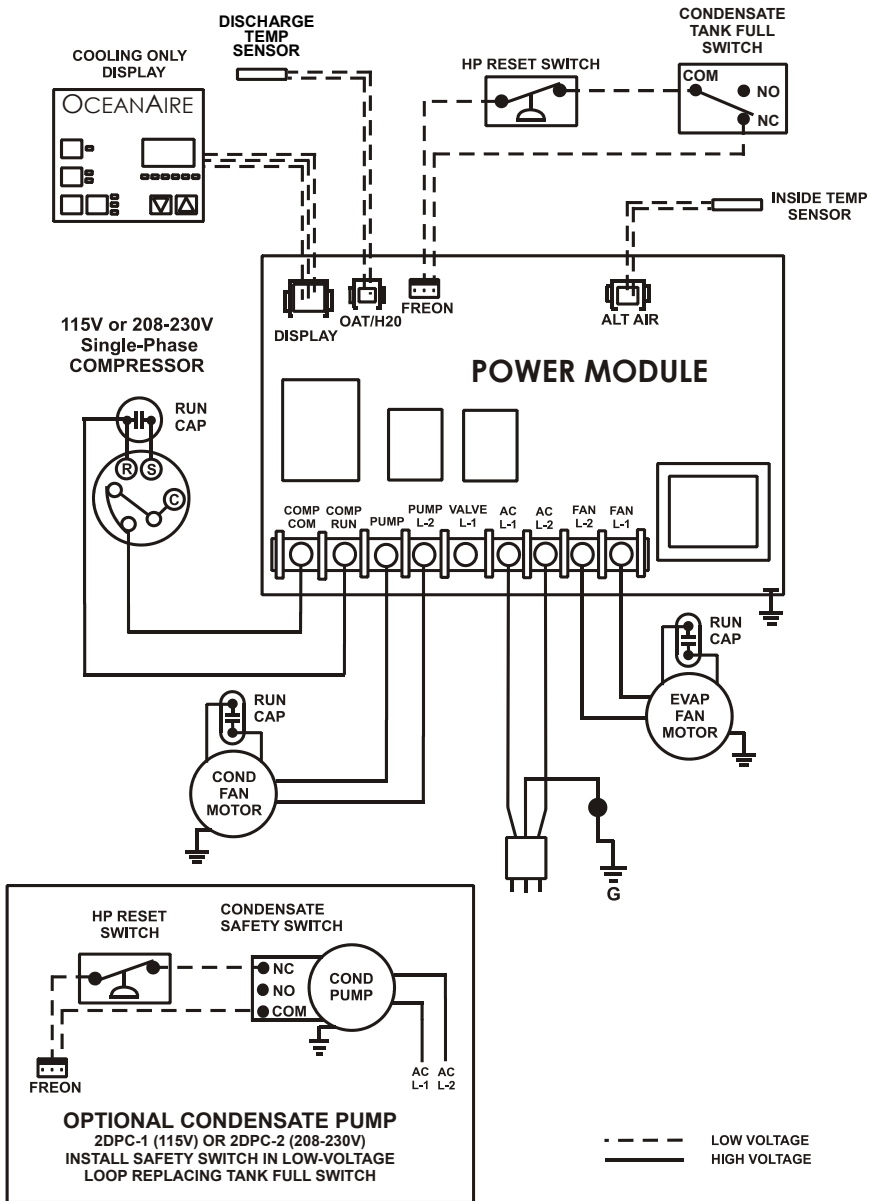

AIR-COOLED SPOT COOLER
MODELS 20AC1211, 20AC1811
115 V / SINGLE-PHASE
MODELS 20AC2412
208-230 V / SINGLE-PHASE

WIRING SCHEMATIC FOR 20AC3612

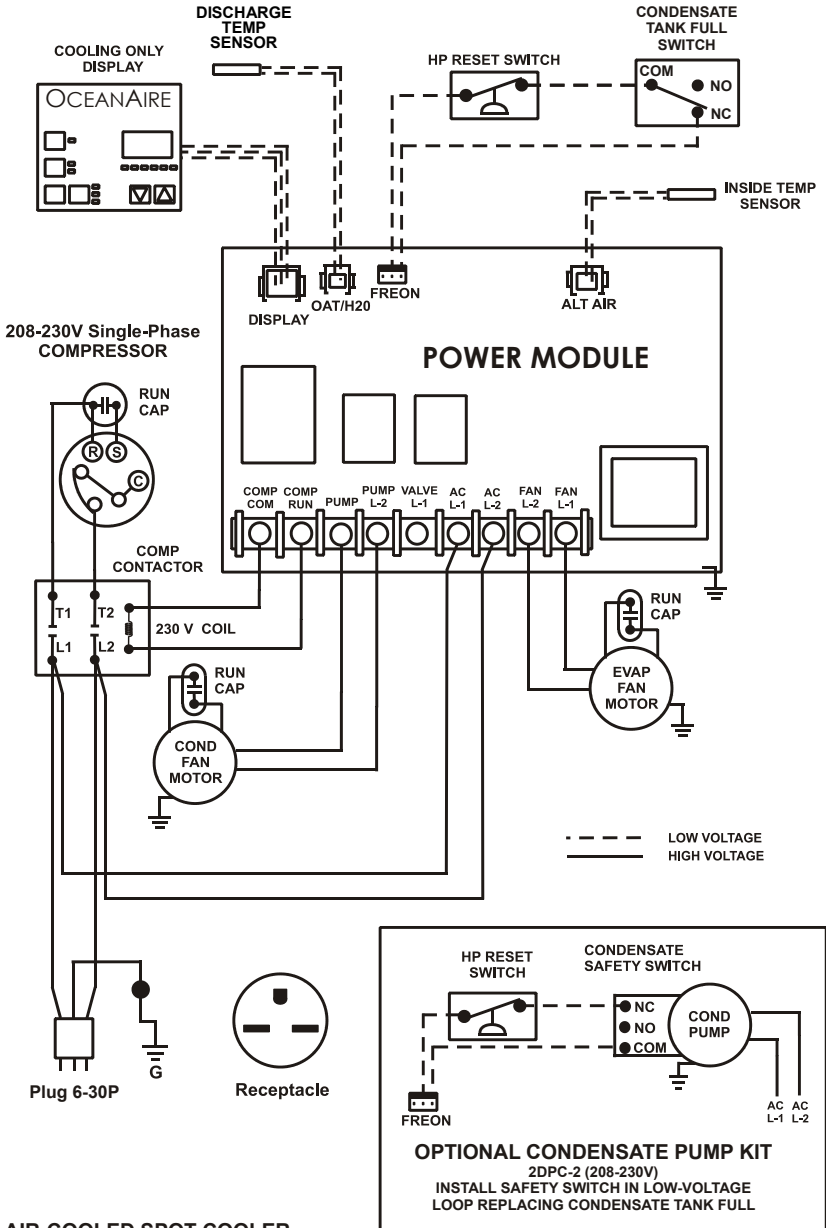

WIRING SCHEMATIC FOR 20AC6012

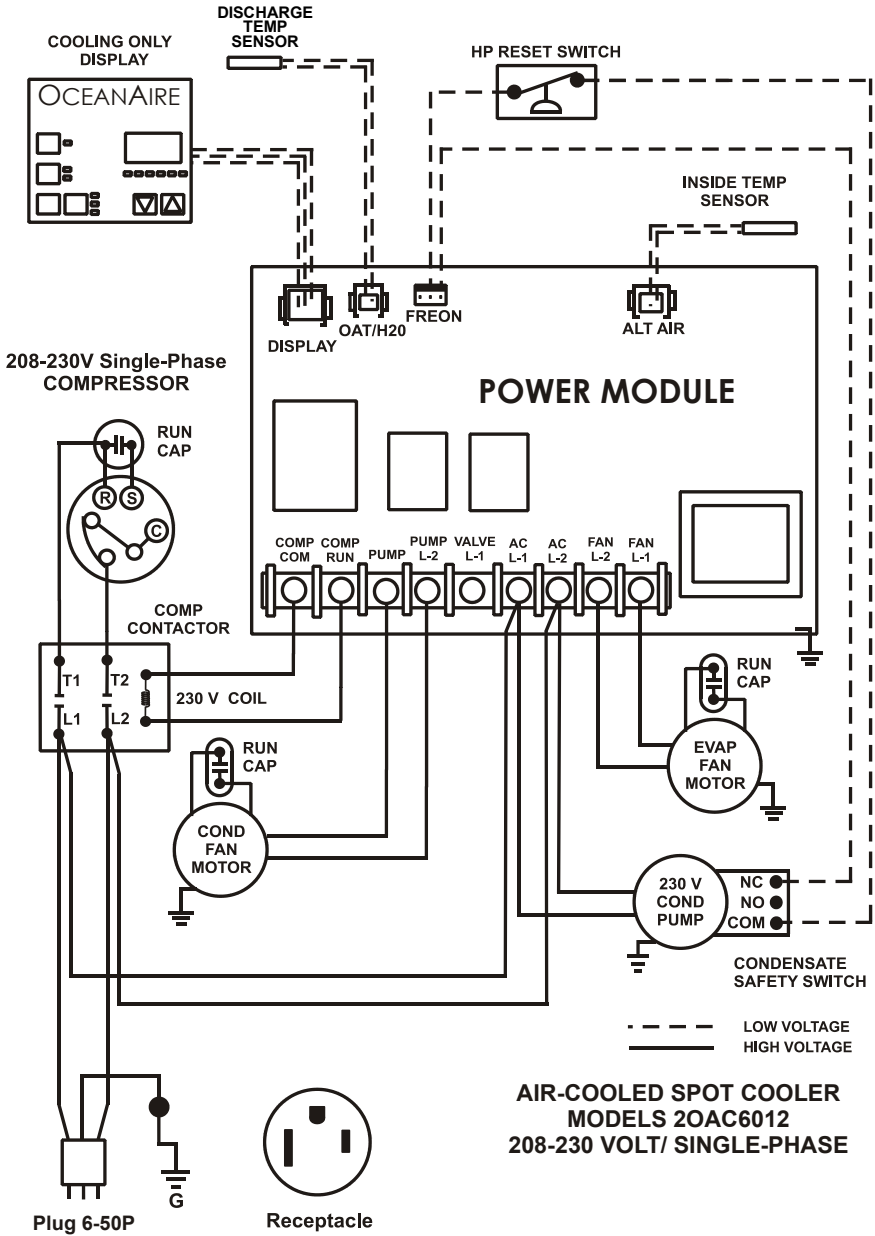

THREE PHASE MONITOR

Three-Phase units are equipped with monitors for motor protection. The OceanAire Three-phase Monitor safeguards the unit against incorrect compressor rotation, low-voltage and/or loss of power in any one of the power legs. The monitor is installed in the control box and is equipped with an LED for diagnosis of an improper electrical condition (see diagrams below). When power is connected, the compressor WILL NOT engage until the monitor start delay has timed out. If the thermostat does not power up, an electrical condition may need to be addressed. Remove the control box cover and observe the LED on the phase monitor. The LED signals the following:

GREEN-BLINKING - Start delay, 120 sec.

GREEN - Proper Operation

RED/GREEN-BLINKING - signals reverse phase rotation. Switch any two of the power leads for the unit, NOT THE MONITOR LEADS, and re-start.

RED-BLINKING - signals improper voltage and/or phase loss. Correct the power problem, then re-start the unit.

In the event of a power interruption, the unit will re-set to a start-up condition. The Phase Monitor will not allow the unit to start until power is corrected.

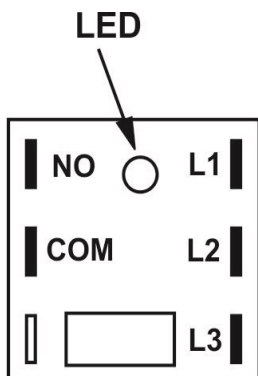

**THREE-PHASE
MONITOR**

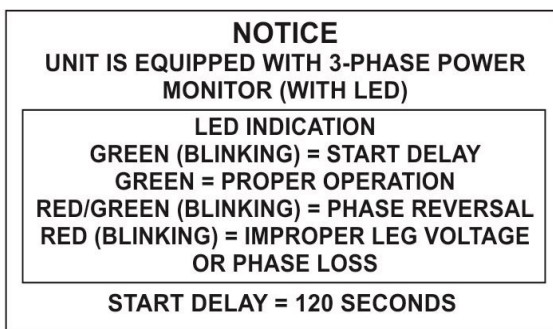

CONTROL BOX LABEL

WIRING SCHEMATIC FOR 20AC3632

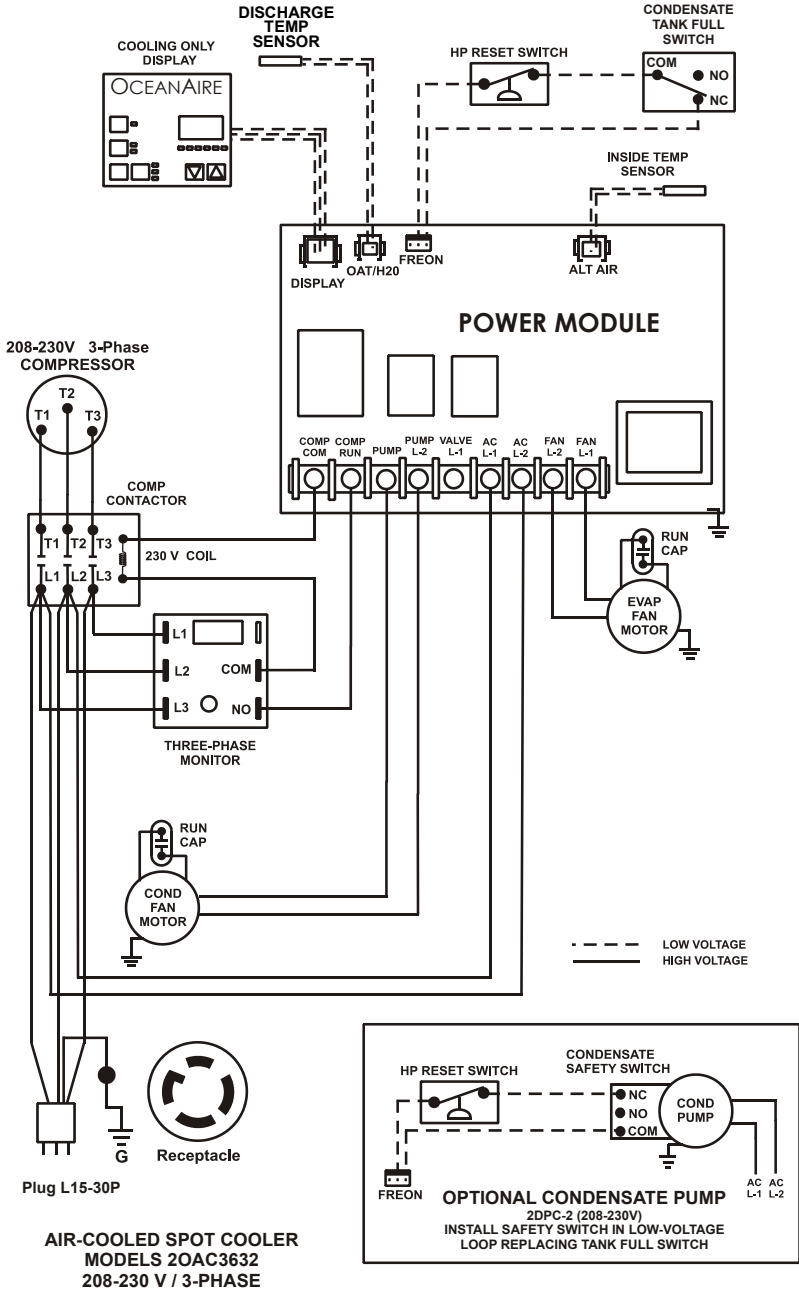

WIRING SCHEMATIC FOR 20AC3634

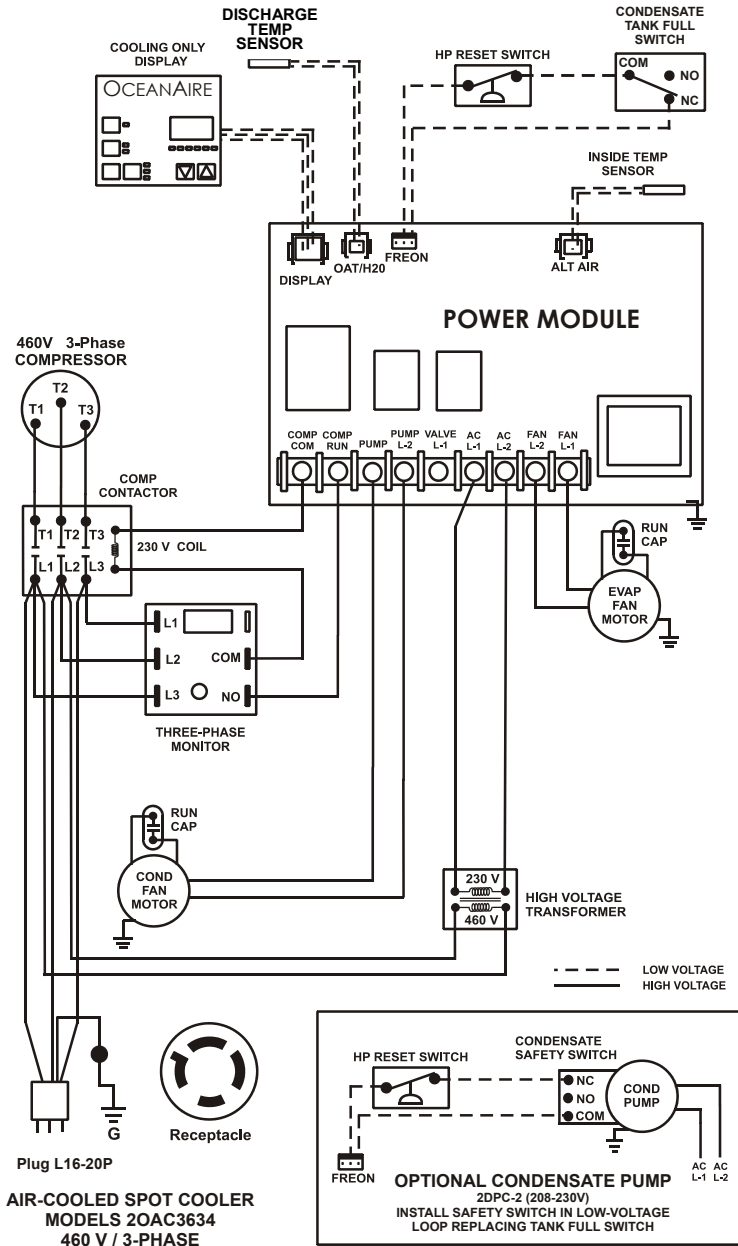

WIRING SCHEMATIC FOR 20AC6032

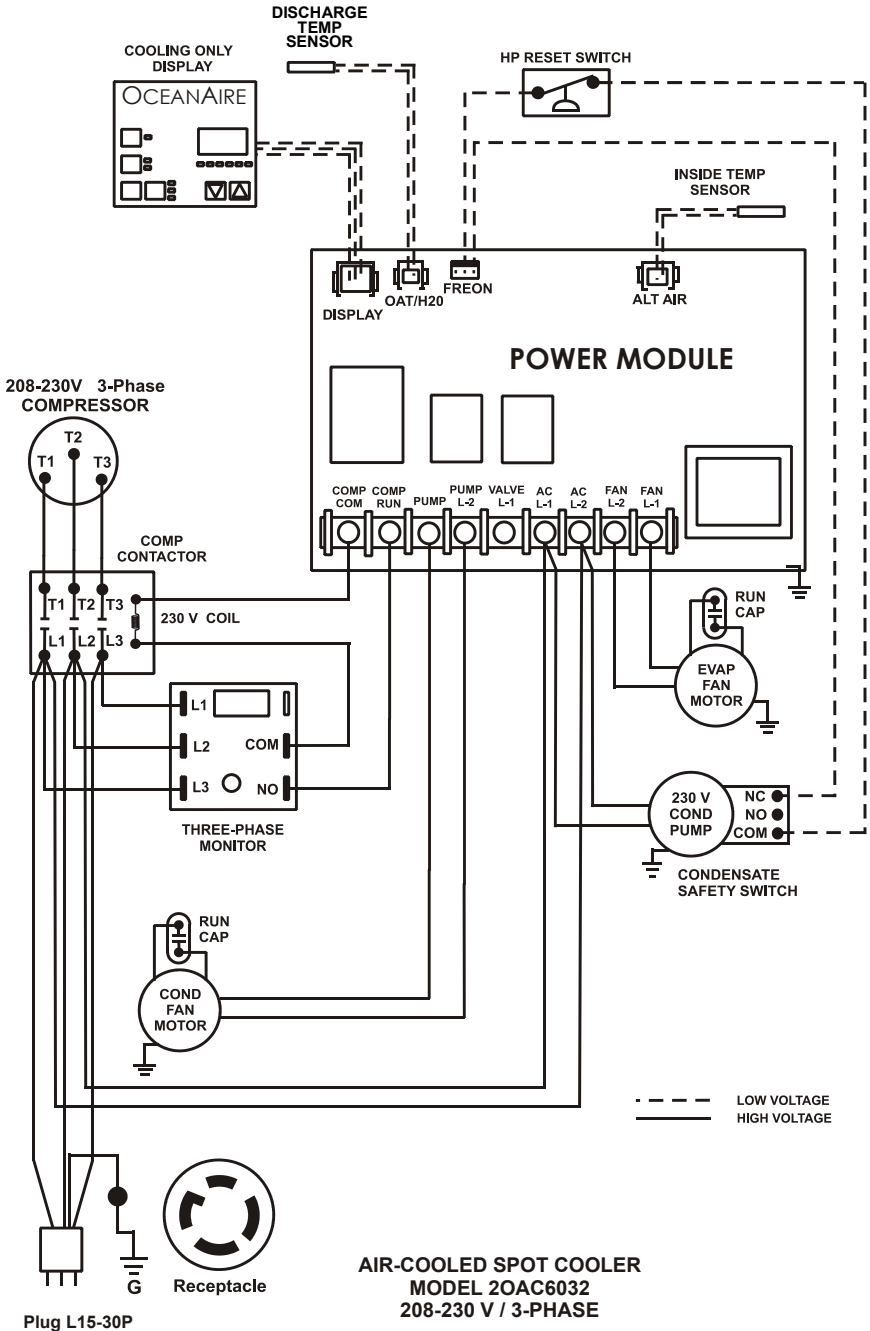

WIRING SCHEMATIC FOR 20AC6034

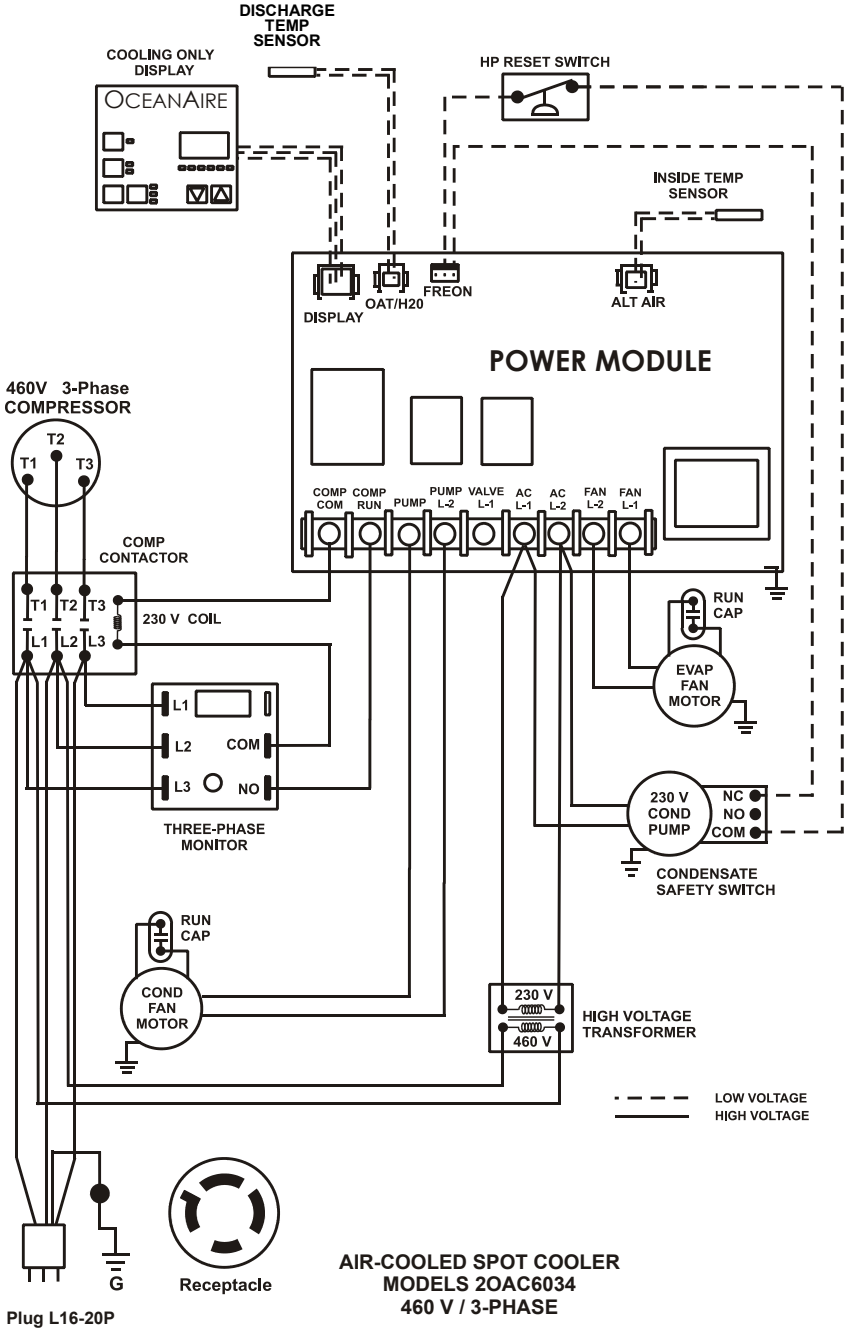

LIMITED WARRANTY

The Manufacturer (OceanAire, Inc.) warrants to the original owner that the Product will be free from defects in material or workmanship for a period not to exceed one (1) year from date of installation. If upon examination by the Manufacturer, the Product is shown to have a defect in material or workmanship during the warranty period, the Manufacturer will repair or replace, at its option, that part of the Product which is shown to be defective.

The Manufacturer further warrants that the product's compressor-motor will be free from defects in materials and workmanship for five (5) years from the date of installation.

If upon examination by the Manufacturer the Product is shown to have a defect in materials or workmanship during the warranty period, the Manufacturer will repair or replace, at its option, that Part of the Product which is shown to be defective. ***Compressor warranty shall be pro-rated for years 2 – 5 at the sole discretion of OceanAire.*** Electrical parts such as relays, overloads, capacitors, etc., and the sealed refrigeration system (condenser and evaporator) are included in the one year limited warranty, but not with the five year limited warranty of the compressor.

This limited warranty does not apply to:

- a) Product that has been subjected to misuse or neglect, has been accidentally or intentionally damaged, has not been installed, maintained or operated in accordance with the furnished written instructions, or has been altered or modified in any way.
- b) Product that has been subjected to any abnormal power conditions such as loss of power, power surges, voltage irregularities such as brown-outs or phase loss on three-phase equipment).
- c) any expenses, including labor or material, incurred during removal or reinstallation of the Product.
- d) any workmanship of the installer of the Product.

This limited warranty is conditional upon:

- a) return to the Manufacturer, of the part of the Product thought to be defective.

Goods can only be returned with prior written approval from the Manufacturer. All returns must be freight prepaid.

- b) determination in the reasonable opinion of the Manufacturer, that there exists a defective in material or workmanship.

Repair or replacement of any part under this Limited Warranty shall not extend the duration of the warranty with respect to such repaired or replaced part beyond the stated warranty period.

THIS LIMITED WARRANTY IS IN LIEU OF ALL OTHER WARRANTIES, EITHER EXPRESSED OR IMPLIED, AND ALL SUCH OTHER WARRANTIES, INCLUDING WITHOUT LIMITATION IMPLIED WARRANTIES OF MERCHANTABILITY OR FITNESS FOR A PARTICULAR PURPOSE, ARE HEREBY DISCLAIMED AND EXCLUDED FROM THIS LIMITED WARRANTY. IN NO EVENT SHALL THE MANUFACTURER BE LIABLE IN ANY WAY FOR ANY CONSEQUENTIAL, SPECIAL, OR INCIDENTAL DAMAGES OF ANY NATURE WHATSOEVER, OR FOR ANY AMOUNTS IN EXCESS OF THE SELLING PRICE OF THE PRODUCT OR ANY PARTS THEREOF FOUND TO BE DEFECTIVE. THIS LIMITED WARRANTY GIVES THE ORIGINAL OWNER OF THE PRODUCT SPECIFIC LEGAL RIGHTS. YOU MAY ALSO HAVE OTHER RIGHTS WHICH MAY VARY BY EACH JURISDICTION.

END USER INFORMATION

MODEL: _____

SERIAL NUMBER: _____

DATE PURCHASED: _____

INSTALLED BY: _____

DATE INSTALLED: _____

For Technical Support, or to locate a distributor for service parts, contact OceanAire at (847) 583-0311 or 1-866-GETAIRE (438-2473). Please indicate the Model Number and Serial Number of the unit to assure proper information and service parts.

TECH NOTES



OCEANAIRE

6228 Oakton Street Morton Grove, IL. 60053
1-866-GET-AIRE (438-2473) Phone: (847) 583-0311 Fax: (847) 583-0312
web-site: www.oceanaire-inc.com e-mail: sales@oceanaire-inc.com