

## “COOL CUBE” Portable IT\* Air Conditioner - Air Cooled

\*INFORMATION TECHNOLOGY

<b>COOLING CAPACITY</b>	<b>12,000 BTUH</b>
VOLTAGE	115 V, 60 Hz, Single Phase
AMPS	12.0 A
WATTS	1180 W
IN RUSH AMPS	63 A
EER	10.0
COMPRESSOR TYPE	Rotary
COMPRESSOR MOTOR	1 HP
COMPRESSOR RLA	9.5 A
COMPRESSOR LRA	50 A
EVAPORATOR BLOWER	CENTRIFUGAL
EVAP CFM - HIGH	400 CFM
EVAP MOTOR HP	1/8 HP
EVAP MOTOR AMPS	1.2 A
EVAP MOTOR WATTS	180 W
CONDENSER BLOWER	CENTRIFUGAL
CONDENSER CFM	490 CFM
CONDENSER MOTOR AMPS	1.4 A
CONDENSER MOTOR WATTS	150 W
POWER CORD	14/3
PLUG TYPE	5-15P, LCDI
CORD LENGTH	10 FT
CONDENSATE REMOVAL SIZE	TANK (PUMP OPTIONAL) 2 GALLON
REFRIGERANT CHARGE	R-410A 18 oz.
HEIGHT WITH CASTERS	24 in.
HEIGHT W/O CASTERS	20 in.
WIDTH	17-1/4 in.
DEPTH	24 in.
NET WEIGHT	130 lb.
SHIPPING WEIGHT	160 lb.
SHIPPING VOLUME	14 cu. Ft.



**AIR COOLED**



### SPECIFICATIONS SUBJECT TO CHANGE WITHOUT NOTICE

- OA **Cooling Capacity** is total BTUH at 80°DB/67°WB return air, 95°F Outdoor at high fan speed
- OA Time Delay fuses/circuit breakers are recommended
- OA EER is determined at high fan speed, with condenser discharge air ducted into another area
- OA CFM with free discharge

### COOLING AMBIENT OPERATING RANGE 65° TO 105° NOT APPROVED FOR OUTDOOR USE

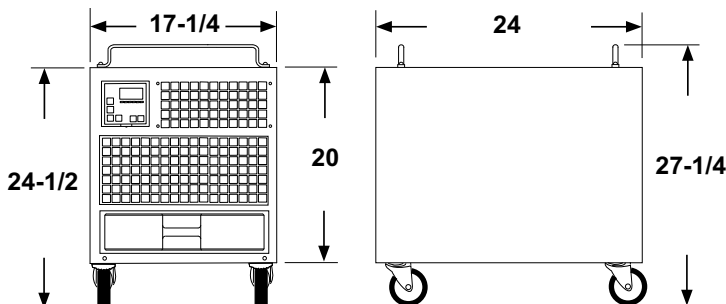

**WARRANTY**  
ALL OCEANAIRE PRODUCTS ARE COVERED BY THE OCEANAIRE LIMITED WARRANTY

1 YEAR ON THE FULL PRODUCT, PLUS 4 ADDITIONAL YEARS FOR THE COMPRESSOR (RESTRICTIONS APPLY)

### PRODUCT FEATURES

- OA SOLID STATE ELECTRONIC CONTROLLER
- OA MANUAL OR AUTO 6-SPEED FAN CONTROL
- OA LARGE LED DISPLAY
- OA CONDENSATE OVERFLOW ALERT
- OA REAR SWIVEL BALL BEARING CASTERS
- OA LOCKING FRONT SWIVEL CASTERS
- OA CONDENSATE OVERFLOW ALERT
- OA LCDI POWER CORD
- OA HIGH PRESSURE SAFETY SWITCH
- OA WASHABLE ELECTROSTATIC AIR FILTERS

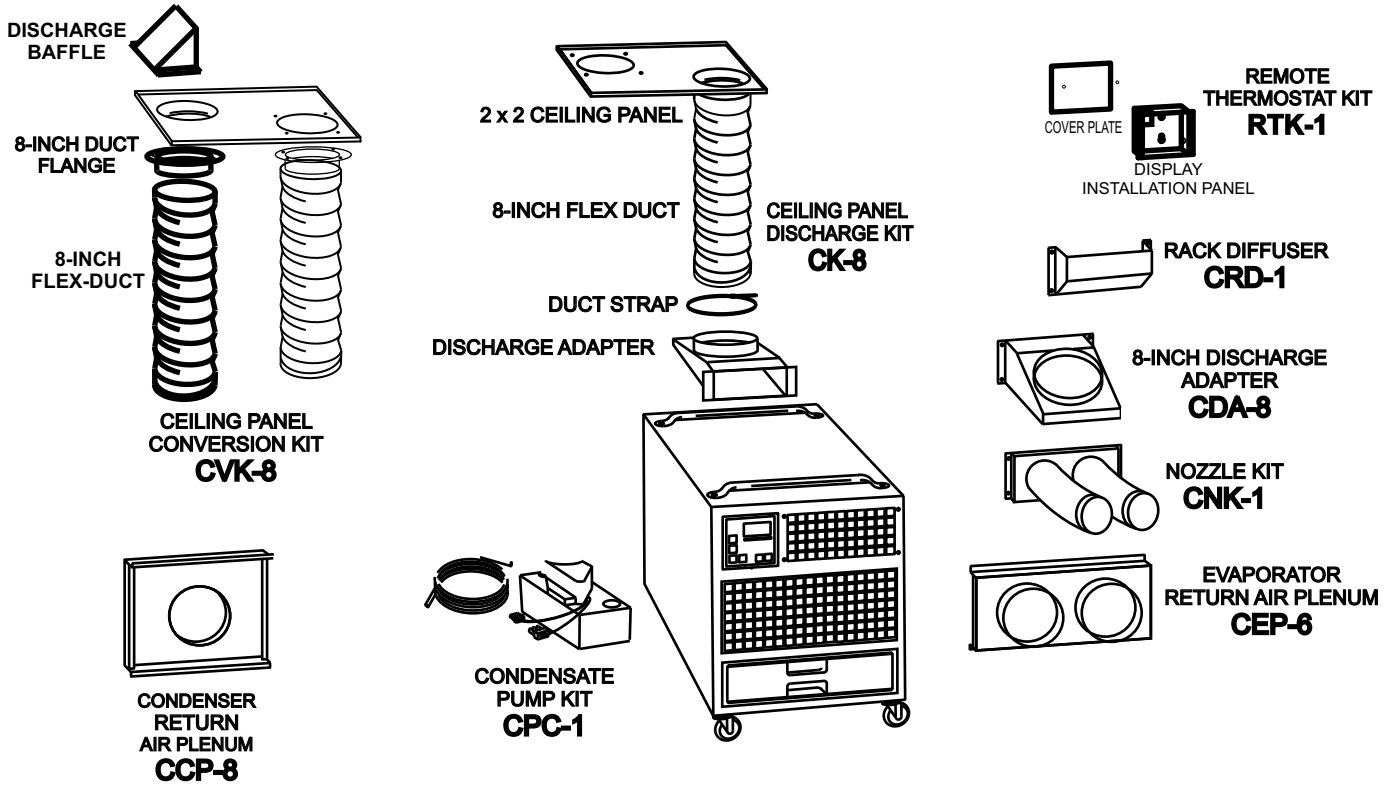

## “ENGINEERED SOLUTIONS”

