



# OWC series

## Deluxe Portable Water-Cooled Spot Cooler

ENGINEERING, INSTALLATION AND SERVICE MANUAL



WATER COOLED



OCEANAIRE

6228 Oakton Street Morton Grove, IL. 60053  
1-866-GET-AIRE (438-2473) Phone: (847) 583-0311 Fax: (847) 583-0312  
web-site: [www.oceanair-inc.com](http://www.oceanair-inc.com) e-mail: [sales@oceanair-inc.com](mailto:sales@oceanair-inc.com)

# **TABLE OF CONTENTS**

	<b>PAGE</b>
<b>GENERAL INFORMATION</b> .....	1
<b>PRODUCT DATA AND SPECIFICATIONS</b> .....	2
<b>UNIT DESCRIPTION</b>	
Standard Features.....	3
Applications / Operation.....	4
Electrical Configurations.....	5
Use of Extension Cords.....	6
Accessories.....	7 - 11
Options / Special Order.....	12
Installation.....	13
Electronic Controller.....	14 - 16
<b>SERVICE</b>	
Water Valve Adjustment, Unit Interior.....	17
Replacement Parts Procedure.....	18
Troubleshooting Guide.....	19
Preventive Maintenance.....	20
<b>DIAGRAMS</b>	
Piping Schematic.....	21
Single Phase Wiring Diagrams.....	22-24
Three Phase Monitor.....	25
Three Phase Wiring Diagrams.....	26 - 28
<b>WARRANTY</b> .....	29
<b>END USER INFORMATION AND TECH NOTES</b> ....	Back Page

## **FORWARD**

This manual provides the user with basic details for the installation and operation of the OceanAire OWC spot cooler. It is recommended to read and fully understand the instructions outlined within this manual, before operating the OWC unit.

As with all commercial air conditioning equipment, it is recommended to have the OWC sized and installed by a licensed specifying engineer and contractor, in accordance with all local and state codes. The length of service received can be extended by following the installation and preventive maintenance instructions.

## **NOTICE**

In our ongoing process of continuous improvement, the items and procedures described in this manual are subject to change without notice. Please note model and serial number of the OWC unit when contacting the factory.

## GENERAL INFORMATION

The OceanAire OWC is a portable water-cooled air conditioner designed for permanent or temporary spot cooling applications. The entire unit has been built in a premium sheet metal cabinet, equipped with heavy-duty casters for mobility. All OWC models come with a 10-foot power cord for electrical connection and added mobility in service. These spot-coolers are designed to direct air to specific areas or objects through a discharge grill located on the upper-front of the unit. The OWC models range in cooling capacities from 12,000 BTU/HR to 60,000 BTU/HR to satisfy most space cooling requirements.

The OWC is a self-contained unit with the entire cooling system (blower assembly, electrical, refrigerant, and waterside components), neatly arranged in a gray polyester powder coated metal cabinet. When connected to the proper source of electrical power, the deluxe electronic controller provides the desired level of comfort and cooling.

A wide variety of accessories and factory installed options are available for the OWC units allowing for improved performance and versatility.

## NOMENCLATURE

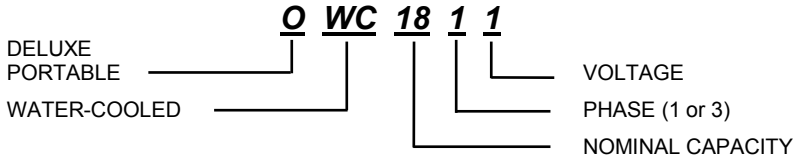

## CAPACITY RATING

12.....	12,000 BTU/HR
18.....	18,000 BTU/HR
24.....	24,000 BTU/HR
36.....	36,000 BTU/HR
60.....	60,000 BTU/HR

## WARRANTY CARD

It is important that the warranty card be filled out completely and returned to the factory within fourteen (14) days of installation of the unit in order to receive the benefits of the warranty.

# SPECIFICATIONS

# OWC

MODEL: OWC	1211	1811	2412	3612	3632	3634	6012	6032	6034	
Cooling Capacity <sup>2</sup>	12,000	18,000	23,950	36,100	36,100	36,100	60,100	60,100	60,100	
Voltage ( Volts/Phase) at 60Hz <sup>1</sup>	115/1		208-230/1		208-230/3		460/3	208-230/1	208-230/3	460/3
Unit Amps <sup>6</sup>	8.1	11.3	9.9	12.0	9.3	4.7	23.7	16.5	6.3	
Unit Watts <sup>6</sup>	930	1300	2100	2700	2700	2700	5000	5000	5000	
In Rush Current (Amps)	56	69	55	100	80	48	165	149	75	
Plug Type	5-15P	5-15P	6-20P	6-20P	L15-20P	L16-20P	6-30P	L15-30P	L16-20P	
EER <sup>4</sup>	12.9	13.8	11.4	13.4	13.4	13.4	12.0	12.0	12.0	
Compressor HP	1	1 1/2	2	3	3	3	5	5	5	
Compressor RLA	9.5	12.3	10.5	13.6	8.8	5.0	27.6	18.1	9.0	
Compressor LRA	50	63	48	83	77	35	158	137	62	
Evap CFM <sup>3</sup>	400	600	810	1200	1200	1200	1950	1950	1950	
Evap Motor HP	1/8	1/8	1/3	1/3	1/3	1/3	1	1	1	
Evap Motor Watts	130	210	350	375	375	420	670	670	670	
Cond Water Flow (GPM) at 60°F inlet	0.75	1.1	1.55	2.2	2.2	2.2	3.8	3.8	3.8	
at 85°F inlet	3	4.5	6	9	9	9	15	15	15	
Cond Coil Pressure Drop-PSI	0.4	0.4	0.4	0.4	0.4	0.4	0.4	0.4	0.4	
Water Valve Pressure Drop PSI	2.0									
Water Valve Connection	3/8 MF				5/8 MF					
Drain (Return) Connection	3/8 MF				5/8 MF					
Condensate Pump (ALL UNITS)	20 Ft Lift - 3/8 MF Connection On Unit - DRAIN									
Sound Level <sup>5</sup>	52	57	60	62	62	62	69	69	69	
R-410A Charge Oz.	14	18	16	24	24	24	52	52	52	
(A) Height with Casters (in.)	31 1/2	37 1/2		50-1/4			51			
(D) Height Without Casters (in.)	28 1/2	34 1/2		45			45-1/4			
(B) Width (in.)	20 1/8	24 1/4		28-1/4			27			
(C) Depth (in.)	13 1/8	13			18		29			
Net Weight (lb.)	125	155	170	275		305	375		410	
Shipping Weight (lb.)	145	175	190	305		335	430		465	
Shipping Volume (cu.ft.)	9	12		23			35			

## SPECIFICATIONS SUBJECT TO CHANGE WITHOUT NOTICE

### NOTES

1. Dedicated Circuit and Time Delay fuse or circuit breaker are recommended
2. Cooling Capacity is total BTUH at 80°DB/67° WB return air, with 85° EWT and 105° LWT
3. CFM with free discharge
4. Cooling EER is determined at high fan speed
5. Sound Pressure, dB at 5 feet, commercial operation
6. Amps & Watts at 208 Volts (208-230 V Models)

### COOLING AMBIENT\*

\* May COOL down to 55° if equipped with hot gas bypass (factory installed)

### OPERATING RANGE 65° TO 105°

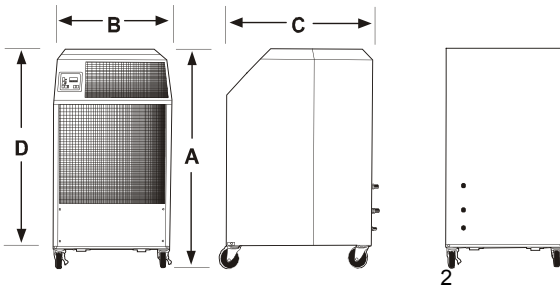

NOT APPROVED FOR OUTDOOR USE

### WARRANTY

ALL OCEANAIRE PRODUCTS ARE COVERED BY THE OCEANAIRE LIMITED WARRANTY

**1 YEAR ON THE FULL PRODUCT**  
PLUS, 4 ADDITIONAL YEARS FOR THE COMPRESSOR  
(RESTRICTIONS APPLY)



**WATER COOLED**

# **STANDARD FEATURES**

## **CABINET**

The OWC-Series cabinet is constructed of 18 gauge steel with a gray polyester powder coated finish that will compliment any decor. The entire cabinet is insulated with sound- absorbing insulation for cool, quiet comfort. All units come equipped with swivel casters for portability and convenient set-up.

## **DELUXE ELECTRONIC CONTROLLER**

All OWC units are equipped with a deluxe electronic controller. When power is connected to the unit, the thermostat will control the unit to cool a space to the desired temperature. The thermostat is also capable of controlling the fan to operate automatically (when needed), or continuously. To protect the compressor from short-cycling, there is a built-in time delay in the thermostat. In the event of a power outage, all thermostat settings are saved, and the unit will re-start automatically.

## **FAN SPEED CONTROL**

The deluxe electronic controller is capable of setting fan speeds automatically or manually. In AUTO mode, the fan speed adjusts in accordance to cooling conditions. In MANUAL mode, the fan speed can be maintained at any one of six speed levels, from low to high.

## **CONDITION ALARM—CON**

The LED thermostat of the OWC will display the word “CON”. CON indicates a fault condition that needs to be addressed:

CONDENSATE PUMP...disabled / restricted drain tube/routed incorrectly

WATER SUPPLY.....turned off / interrupted flow

EITHER CONDITION WILL TRIP THE HIGH PRESSURE SAFETY SWITCH. See below.

## **CONDENSATE PUMP**

All OWC units come equipped with an Automatic Condensate Pump that removes the condensate. The pump discharges through a 3/8 male flare DRAIN connection located on the back of the unit. The pump is capable of pumping to a 20-foot height, to handle almost any installation requirement.

## **HIGH PRESSURE (HP) SWITCH**

Located on the back of the OWC unit is a manual re-set high pressure switch, used for the protection of the compressor in the event that the condenser water supply is turned off. If the condensing pressure exceeds the limit setting, the switch cycles off the compressor, while the evaporator fan remains running, and the default “CON” will display on the controller. The high pressure switch is also wired **in series** with the condensate pump. If a failure occurs with the operation of the pump circuit, the HP switch will open. Once the water interruption/condensate pump failure has been corrected, turn the unit off, reset the switch by depressing the **red RESET button** on the back of the unit, and restart the unit.

## **FILTERS**

All OWC units are equipped with a washable filter at the air intake. An electrostatic mesh air filter is located behind the evaporator return air grille to filter the air before it is cooled, keeping the coil free from dust build-up. The filter can be easily removed and cleaned.

## **POWER CORDS**

All OWC units come standard with a power cord for a convenient connection. All models, except for the 3-phase units and 5-ton units, are equipped with LDCI for added safety features.

# APPLICATIONS

## SPOT COOLER

The OWC can be used in an open environment to cool specific objects or "spots". Spot Cooling is a convenient and economical way to provide air conditioning where cooling the entire space is impractical. Cool air is discharged from the unit and is directed where it is needed. Nozzle kits can be used to improve direction of the cooling airflow.

## ROOM AIR CONDITIONER

One feature of the OWC is it operates as a room air conditioner because it uses water as the means for heat rejection. The major advantage of water-cooled air conditioning is the convenience of connecting water hoses, or lines, as compared to the installation of condenser air ducts used for air-cooled portables. A variety of hose kit lengths are available that can be used for connecting to a water supply and drain, while providing portability within the conditioned space.

## OWC—OPERATION / DESCRIPTION

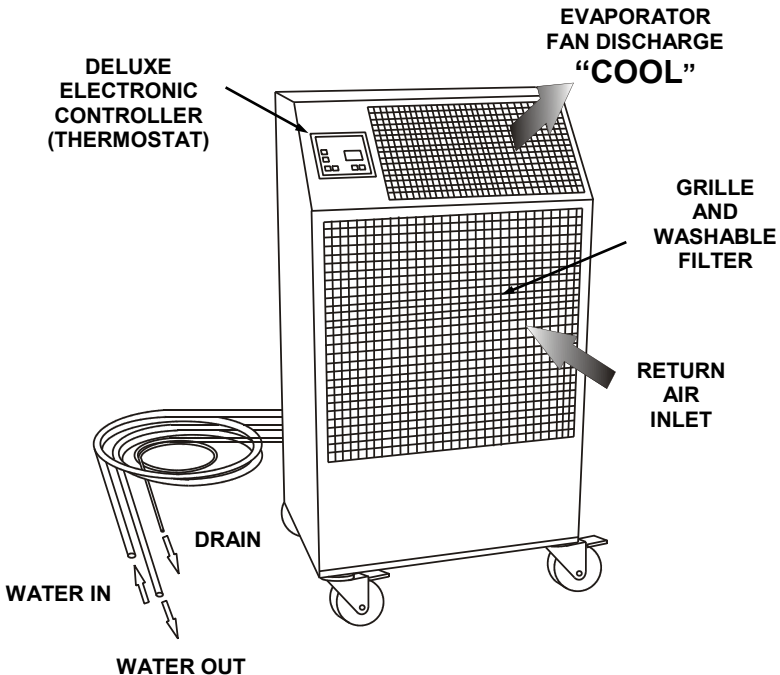

# ELECTRICAL CONFIGURATION







All OWC Series units are equipped with a standard 10-foot long service cord with plug configurations and receptacle requirements as shown in this chart. OWC1211, OWC1811, OWC2412 and OWC3612 units come with LCDI (Leakage Current Detection & Interruption) devices that serve as a means of electrical protection.

## CAUTION

**DO NOT USE THE LCDI AS AN ON/OFF SWITCH FOR THE UNIT**

All 3-phase models are equipped with locking plugs for added connection reliability. Refer to the chart below for plug and receptacle details for all OWC models.

**A DAMAGED LCDI POWER SUPPLY CORD MUST BE REPLACED WITH A NEW POWER SUPPLY CORD AND NOT REPAIRED**

UNIT/MODEL	PLUG CONFIGURATION	RECEPTACLE
<u>115 VOLT</u> OWC1211 OWC1811	 15A-125 VOLT NEMA 5-15P	NEMA 5-15R
<u>208-230 VOLT SINGLE PHASE</u> OWC2412 OWC3612	 20A-250 VOLT NEMA 6-20P	NEMA 6-20R
<u>208-230 VOLT SINGLE PHASE</u>  OWC6012	 30A-250 VOLT NEMA 6-30P	NEMA 6-30R
<u>208-230 VOLT 3-PHASE</u>  OWC3632	 20A-250 VOLT NEMA L15-20P	NEMA L15-20R
<u>208-230 VOLT 3-PHASE</u>  OWC6032	 30A-250 VOLT NEMA L15-30P	NEMA L15-30R
<u>460 VOLT 3-PHASE</u> OWC3634 OWC6034	 20A-460 VOLT NEMA L16-20P	NEMA L16-20R

## **USE OF EXTENSION CORDS**

### **CAUTION**

**FOR MODELS OWC1211 AND OWC1811** AN EXTENSION CORD CAN BE USED PROVIDED IT IS RATED AT LEAST 15 AMPS @ 115 VOLTS WITH GROUNDING-TYPE ATTACHMENT PLUG AND GROUNDING TYPE CONNECTOR (LOAD FITTING)

**FOR MODELS OWC2412 and OWC3612** AN EXTENSION CORD CAN BE USED PROVIDED IT IS RATED AT LEAST 20 AMPS @ 250 VOLTS WITH GROUNDING-TYPE ATTACHMENT PLUG AND GROUNDING TYPE CONNECTOR (LOAD FITTING)

**FOR MODEL OWC6012** AN EXTENSION CORD CAN BE USED PROVIDED IT IS RATED AT LEAST 30 AMPS @ 250 VOLTS WITH GROUNDING-TYPE ATTACHMENT PLUG AND GROUNDING TYPE CONNECTOR (LOAD FITTING)

**FOR MODEL OWC3632** AN EXTENSION CORD CAN BE USED PROVIDED IT IS RATED AT LEAST 20 AMPS @ 250 VOLTS, 3 PHASE

**FOR MODEL OWC6032** AN EXTENSION CORD CAN BE USED PROVIDED IT IS RATED AT LEAST 30 AMPS @ 250 VOLTS, 3 PHASE

**FOR MODELS OWC3634 AND OWC6034** AN EXTENSION CORD CAN BE USED PROVIDED IT IS RATED AT LEAST 20 AMPS @ 600 VOLTS, 3 PHASE

### **SPECIAL NOTICE—THREE PHASE OPERATION**

#### **Models OWC3632, OWC3634, OWC6032 and OWC6034**

All three-phase OWC models are equipped with a three-phase monitor for added compressor protection. The phase monitor, located in the control box, has multi-color LED that reports status. The monitor protects the compressor from reverse operation, phase loss and low voltage situations. Further description of the three-phase monitor is located in the electrical section of the manual.

**NOTICE** - DO NOT OPERATE ANY THREE-PHASE UNIT WHILE BY-PASSING THE MONITOR. **THIS WILL VOID THE WARRANTY.**



# OWC ACCESSORIES

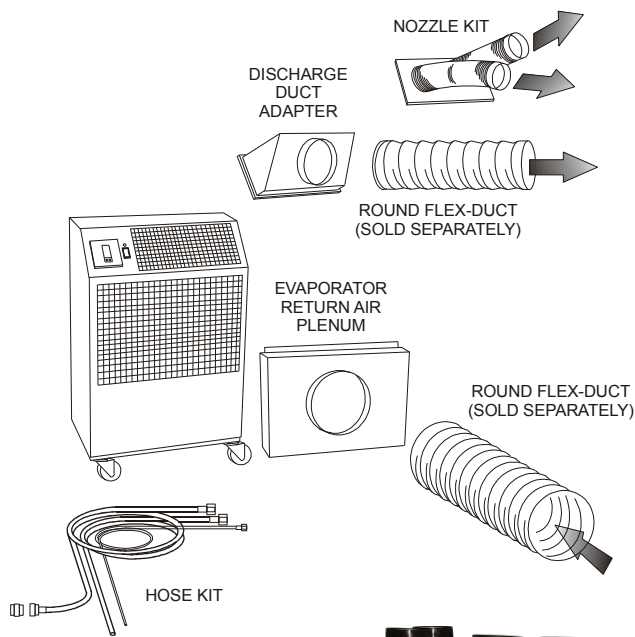

## NOZZLE KIT

NK-1	(2 X 4-Inch)	OWC12
NK-2	(2 X 6-Inch)	OWC18, 24
2NK-3	(2 X 8-Inch)	OWC36, OWC60



## EVAPORATOR RETURN AIR PLENUM

DEP-10	(10-Inch Round)	OWC12
2DEP-12	(12-Inch Round)	OWC18, 24
DEP-16	(16-Inch Round)	OWC36, 60



## DISCHARGE DUCT ADAPTER

DDA-6	(6-Inch Round)	OWC12
DDA-10	(10-Inch Round)	OWC18, 24
2DDA-16	(16-Inch Round)	OWC36, OWC60



## HOSE KIT

HK-1	10FT	OWC 12, 18, 24
HK-2	25FT	OWC 12, 18, 24
HK-5	40FT	OWC 12, 18, 24
HK-3	10FT	OWC 36, 60
HK-4	25FT	OWC 36, 60
HK-6	40FT	OWC 36, 60



# ACCESSORIES

## DISCHARGE AIR NOZZLE KIT ASSEMBLY

The optional discharge nozzle kits are used to direct the conditioned air to a specific target area. By concentrating the airflow, the nozzles increase the air velocity towards production lines to cool personnel and/or equipment. In server rooms, the nozzles can be used to direct the airflow through the rack to remove the hot air from the area of the equipment.

**NK-1 for model OWC12**, with (2) 4-inch diameter nozzles with an approximate compressed length of 15 inches. The approximate extended length is 21 inches.

**NK-2 for models OWC18 and OWC24** with (2) 6-inch diameter nozzles with an approximate compressed length of 22 inches. The approximate extended length is 32 inches.

**2NK-3 for model OWC36 and OWC60** , with (2) 8-inch diameter nozzles with an approximate compressed length of 20 inches. The extended length is approximately 29 inches.

The nozzle kits come pre-assembled with the nozzles secured to a mounting plate, and with edge guards. By removing the OWC discharge grill, you can insert the nozzle kit into the opening without the use of tools.



# ACCESSORIES

## EVAPORATOR RETURN AIR PLENUM

Evaporator return air plenums are available for installations where it is required to duct air to the inlet of the evaporator. The evaporator return air plenums allow the user to connect round duct (flexible or rigid) to the return air intake to reduce air noise and increase the number of options for solving difficult cooling problems. The plenum attaches to the front of the unit, replacing the return air grille. Refer to the table below for configuration and application information

**DEP-10** for **OWC12** transitions the return air opening to a 10-inch round duct.

**DEP-12** for **OWC18** and **OWC24** transitions the return opening to a 12-inch round duct.

**DEP-16** for **OWC36** and **OWC60** transitions the return opening to a 16-inch round duct.

**NOTE**—When a DEP is installed, it is recommended to set the evaporator blower speed to high, to avoid evaporator coil freeze-up.

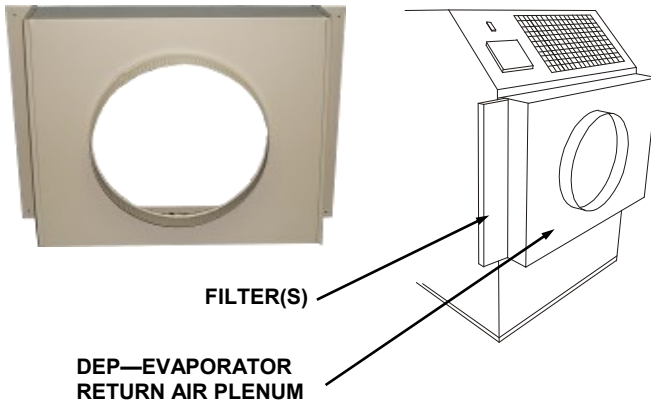

Plenum Kit Duct/Flange	OWC12	OWC18	OWC24	OWC36	OWC60	FILTERS
<b>DEP-10</b> 10 inch	✓					(1) 10"X20"X1"
<b>DEP-12</b> 12 inch		✓	✓			(1) 16"X24"X1"
<b>DEP-16</b> 16 inch				✓	✓	(1) 10"X30"X1" (1)15"X30"X1"
<b>Maximum Equivalent Feet</b>	25	50	50	50	100	
<b>Est. External Static Pressure</b>	(.20)	(.25)	(.25)	(.25)	(.50)	

# ACCESSORIES

## DISHARGE DUCT ADAPTER

Discharge duct adapters are available for applications where ducted evaporator discharge is required. The adapters can be easily installed on the unit without fasteners, and be installed for either vertical or horizontal ducting. The standard discharge grille is removed and the DDA is attached in the grille opening.

**DDA-6 for OWC12**, converts the evaporator discharge to a 6-inch diameter round duct.

**DDA-10 for OWC18 and OWC24**, converts the evaporator discharge to a 10-inch diameter round duct.

**2DDA-16 for OWC36 and OWC60**, converts the evaporator discharge to a 16-inch round duct.

When used in conjunction with the evaporator return air plenum, DEP, the unit can provide closed-loop cooling to and from a given space without the influence of any outside air.

**NOTE—When a DDA is installed, it is recommended to set the evaporator blower speed to high, to avoid evaporator coil freeze-up.**



Adapter Model	Round Duct Size	OWC12	OWC18	OWC24	OWC36	OWC60
DDA-6	6-inch	✓				
DDA-10	10-inch		✓	✓		
2DDA-16	16-inch				✓	
Maximum Approx. Equivalent Feet		25	50	50	50	100
Maximum E.S.P		.15	.25	.25	.25	.50

# ACCESSORIES

## HOSE KIT

Hose kits are available in lengths of 10, 25, and 40 feet. Each hose kit allows for convenient installation of the OWC, while allowing for portability within the allowable space.

**NOTICE**—When using these hoses in applications with water pressures exceeding 50 PSIG, a water pressure reducing valve must be installed in the water supply line prior to the hose kit; otherwise warranty on the hose kits will be void.

All hose kits have FEMALE flare connectors to match the MALE flare fittings on the units (see chart below). The WATER IN connector consists of a 3/4" hose barb. WATER OUT and DRAIN (condensate) have no fittings, and can be fed to a sink or permanent drain. When using a hose kit, avoid sharp corners, hot water pipes and kinking to assure proper water flow of the supply, return, and drain lines.

Hose Kit	Length	Flare Conn IN-OUT-DRAIN	OWC12	OWC18	OWC24	OWC36	OWC60
HK-1	10 ft	3/8 3/8 3/8	✓	✓	✓		
HK-2	25 ft	3/8 3/8 3/8	✓	✓	✓		
HK-5	40 ft	3/8 3/8 3/8	✓	✓	✓		
HK-3	10 ft	5/8 5/8 3/8				✓	✓
HK-4	25 ft	5/8 5/8 3/8				✓	✓
HK-6	40 ft	5/8 5/8 3/8				✓	✓

Included with the hose kit is a sink/faucet adapter



## **SPECIAL ORDER ITEMS**

In some applications, units can be manufactured with optional components for added performance and longevity. Below are a few of the OWC options that are available.

**Consult your distributor for pricing and availability.**

### **CUPRO-NICKEL CONDENSER**

When chemically treated water, salt water or brine, is used in the condenser coil, it is recommended that the OWC be equipped with a 90/10 Cupro-Nickel condenser coil.

### **HIGH PRESSURE WATER VALVE**

For applications where water supply pressures exceed 150 psig, a high pressure water regulating valve can be installed in the OWC. Valves designed for use with up to 350 psig water inlet pressure are available.

### **HERESITE TREATED EVAPORATOR COIL**

For use in chemically corrosive environments, the OWC can be manufactured with a Heresite® coated evaporator coil for improved coil life.

### **HOT GAS BYPASS VALVE**

In applications where low evaporator temperatures may occur, an optional hot gas bypass valve can be installed to regulate the evaporator temperature. The bypass valve feeds refrigerant (hot gas) into the evaporator to avoid low ambient freeze-ups.

### **MARITIME WATER VALVE**

Cast naval bronze body with MONEL parts. MONEL is a “natural alloy” and is highly resistant to corrosion.

### **TOWER UNITS**

In applications where the OWC is connected to a closed-loop condenser water circuit, a unit can be built for direct water connection **WITHOUT** a water valve.

# **INSTALLATION INSTRUCTIONS**

## **RECEIVING—INSPECTION**

Upon receiving your unit, inspect the packaging for any damage. All units are shipped on a skid, and packaged in a triple-wall carton for added protection.

## **BEFORE INSTALLING**

Check the unit for any damage. All OceanAire products are thoroughly inspected at the factory and carefully packaged. If any damage is evident, contact OceanAire **IMMEDIATELY**.

## **ELECTRICAL REQUIREMENTS**

Check the nameplate located on the back of the unit to confirm the proper power is available for the unit. **Refer to "Specifications"** section for voltage and amperage requirements. For proper NEMA receptacles, refer to "Electrical service plug configuration". When using extension cords, use the proper gauge cord, and check cord voltage to the unit.

**TIME DELAY FUSES/CIRCUIT BREAKERS ARE RECOMMENDED**

## **WARNING—OPERATING THE UNIT ON IMPROPER VOLTAGE WILL VOID THE WARRANTY**

## **ACCESSORIES**

Verify that all accessories are correct for the model, and are installed in accordance with all instructions.

## **START-UP**

Install the unit in accordance with all local and state building codes, and install all accessories. Allow for a clearance around the unit for future maintenance and/or service. Level unit and lock casters, when available. Connect power and test the LCDI on the power cord (if available). Power up unit, via thermostat and check for proper operation. Refer to Thermostat Operation for more details.

# DELUXE ELECTRONIC CONTROLLER

The OWC controller is equipped with many features for a more precise level of cooling and operation. Additionally, the controller can be removed from the unit and installed for remote operation when using an extended display cable. Also, with the addition of a remote sensor, the controller can operate away from the unit while sensing temperatures in another space or in ductwork, overriding the inside temperature sensing bulb on the bottom of the thermostat— accessory parts may be required.

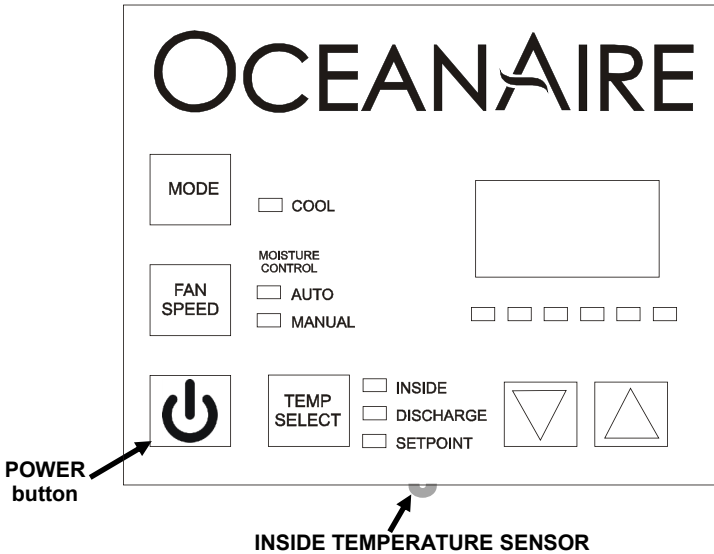

## OCEANAIRE DELUXE ELECTRONIC CONTROLLER

When power is connected, the controller will display "888" momentarily, and then disappear. Press the POWER button, then press the TEMP SELECT button until the SET POINT is displayed. Adjust the SET POINT to the desired temperature, and the unit will cool as required.

### The systems controls temperature within +/- 2°

**POWER**—Turns the unit on/off when power is supplied

**MODE** - Selects the mode of operation between Cool and Moisture Control.

**COOL** - The system will operate in cooling mode only.

**MOISTURE CONTROL** - The system operates in the cooling mode to reduce humidity within the conditioned space.

Every 4 hours, the fan is started, circulating the air, and the air temperature is recorded by the controller. The cooling cycle is started for one hour, or until the room temperature drops 2°, which ever comes first. This cycle repeats every four hours.



**FAN SPEED**—The operator can select between **AUTO** or **MANUAL** fan speed control. Pressing the **FAN SPEED** button will switch speed from **AUTO** to **MANUAL**. In **MANUAL** mode, pressing the **FAN SPEED** button will change fan speed from low to high. In **AUTO** mode, the fan speed is controlled automatically. In cooling mode, the controller automatically adjusts the fan speed to high, and as the inside temperature approaches the set point, the fan speed will decrease.

**TEMP SELECT**— Allows the operator to view the controller temperatures **INSIDE** = return air temperature, **DISCHARGE** = supply air temperature, **SET POINT** can be seen and adjusted, by pressing ▲ or ▼.

## CONTROLLER PROGRAMMING MENU

- 1) Make sure the unit has power .
- 2) Press the  power button “OFF”.
- 3) Press the following buttons in sequence “**S-U-D-S**”  
(Select—Up arrow — Down arrow — Select)
- 4) The display will begin flashing P1 and a number.



*If there is no display, repeat the sequence, making sure the unit has power, but is turned OFF.*

- 5) To adjust any program feature, press the **ARROW UP** ▲ or **ARROW DOWN** ▼ button until the desired value is displayed.
- 6) Use the “**MODE**” button to scroll through the programmable settings P1 through P16.
- 7) If no buttons are pressed, the display will then return to the “**OFF**” position after about 50 seconds.

## PROGRAM SETTINGS

**P1**—High Fan Speed Limit Setting. 56 - 85

**P2**—Low Fan Speed Limit Setting, 30 - 55

**P4**—Temperature Sensor Calibration, +/- 10°

**P10**— Temperature Display, °F or °C

**P13**—Supply Fan Operation, Cycling or Continuous

**P15**—Fan Motor Type Setting, PSC or Shaded Pole

**P1, P2** - To adjust fan speed settings, **P1** represents the high fan speed parameter, while **P2** represents the low fan speed parameter. When using nozzle kits, discharge duct adapters and evaporator plenums, setting **P1** to 85 will help to avoid freeze ups.

**P4** - Adjust the **P4** setting to match the actual **INSIDE** room temperature, if needed.

**P10** - Use this parameter to display temperatures in the desired units.

**P13** - To cycle the evaporator fan with the compressor, access code **P-13**. Press the up or down button to switch to “**CYC**”, which means cycle the fan with the compressor. The factory default setting is “**CON**”, which means continuous fan operation.

**P15** - Fan Motors are PSC type, **SC** - should be selected.

8) Press **POWER** — you should see an alphanumeric code.

Press **POWER** and the unit will start at the new settings

# OWC PROGRAM SETTINGS

MODEL	CODE SETTINGS
OWC12	P1 = 65, P2 = 45
OWC18	P1 = 80, P2 = 50
OWC24	P1 = 70, P2 = 50
OWC36	P1 = 85, P2 = 40
OWC60	P1 = 85, P2 = 45

## NOTICE

**Program Parameters are NOT controller default values.  
They are OceanAire Factory Settings**

## DISPLAY FAULTS

**LAC**..... Low AC line power

**AAA**..... Failed Air Sensor (unit will not run)

**CON**..... Failed Condensate Pump/Over-Flow Alarm  
High Pressure Cut-Out—Low/interrupted condenser water supply. Correct problem, and re-set unit at HP RESET

## TO CHECK THE NUMBER OF HOURS ON THE UNIT

- 1) Disconnect unit power, and reconnect unit power.
- 2) When “888” appears in display, push and release the arrow down button



- 3) The first set of numbers displayed reads thousands of hours:  
02 = 2000, 04 = 4000 hours, 00 means less than 1000 hours.
- 4) The second set of numbers read hours directly:  
58 = 58 hours. 742 = 742 hours.
- 6) Add the 2 number sets together to get total hours. 03 and 486 = 3486 hours. 01 and 59 = 1059 hours.

**TOTAL HOURS REPRESENTS COMPRESSOR “RUN” TIME**

# WATER VALVE ADJUSTMENT

All OWC units come equipped with an automatic pressure regulated water valve which controls the condenser water flow rate. The water valve will open when the system is running, and will adjust the water flow rate based on the temperature of the supply water.

In some cases, water temperatures can cause the valve to open and close at a high rate, causing a “chattering” condition in the water supply line. In these cases, it is recommended that the water valve be adjusted.

1. Disconnect the unit power.
2. Remove the unit back panel and locate the water regulating valve in the lower right region of the unit.
3. Locate the water valve adjustment screw. At the top of the valve there is a square-shaped adjustment screw.
4. Turn the adjustment screw 1/4 turn **CCW** to raise the low side operating pressure...or...**CW** to lower the low side operating pressure.
5. Re-install the back panel and turn the unit on.

Water Valve Adjustment Screw

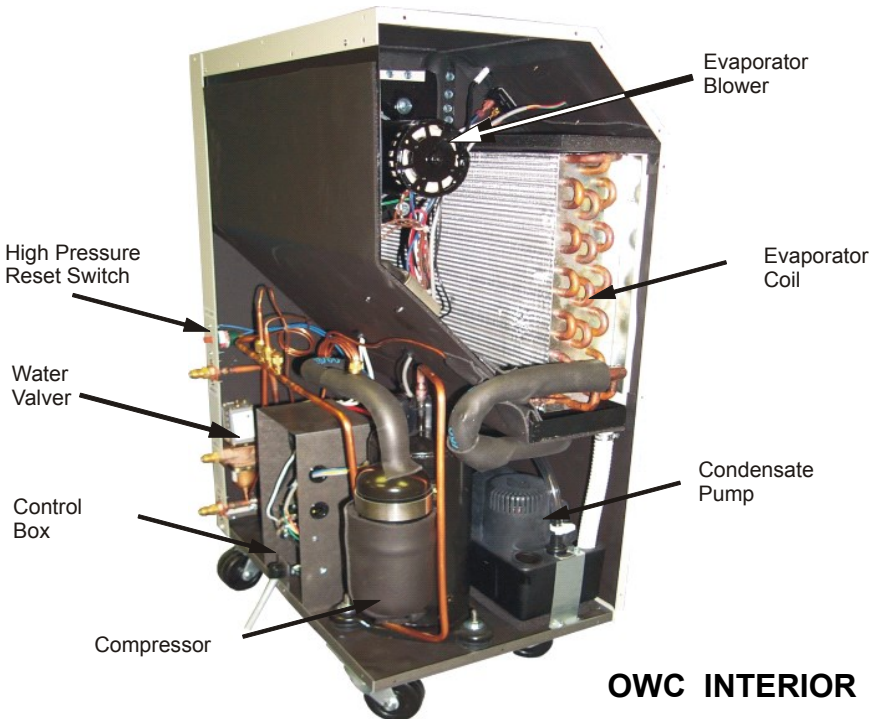

OWC INTERIOR

# **REPLACEMENT PARTS PROCEDURE**

**IT IS RECOMMENDED THAT ALL OCEANAIRE UNITS  
BE SERVICED BY A LICENSED TECHNICIAN**

***WARNING—TO AVOID INJURY, DISCONNECT UNIT POWER  
PRIOR TO SERVICING***

## **A. FAN MOTOR**

1. Remove cabinet left-side panel (when looking at the front of the unit).
2. Evaporator fan motor—disconnect evaporator motor wires from evaporator fan contactor and power module.
3. **For all model sizes 12, 18, 24, and 36**, remove the screws securing motor and inletting to blower housing (all screws are external and visible), and remove blower wheel-motor assembly. Remove the blower wheel set screw and disassemble the blower wheel from the motor shaft and remove the motor.  
**For model size 60**—loosen blower wheel shaft set screw, and remove the screws securing the motor mount to the blower housing and remove motor and mount. Remove the motor from the motor mount.
4. Install the new motor, reversing the removal procedure.

## **B. ELECTRONIC CONTROLLER (THERMOSTAT)**

To replace cooling only thermostat, simply remove the (2) screws on the sides of the controller. Lift up the controller to unplug the display cable and remove. Plug display cable into new thermostat, and secure in place.

## **C. POWER MODULE**

To remove the power module, remove the rear control box cover. Disconnect wires (one at a time), and re-attach each wire, while holding replacement module in other hand. Once all wires have been reconnected in accordance with the wiring diagram, install new power module.

## **D. CONDENSATE PUMP**

1. Remove left side panel.
2. Remove brackets securing condensate pump in base pan.
3. Disconnect pump wire leads at Molex connectors. Remove retainer clamp and tubing.
4. Replace pump, install by reversing procedure.

## **E. HIGH PRESSURE SAFETY SWITCH**

1. Remove cabinet right side panel, or rear panel of Model 60.
2. Remove flare nut that secures capillary to the refrigeration system high pressure side. A schrader valve is located in the discharge port which allows removal without losing the refrigerant charge.
3. Remove two screws that secure high pressure switch.
4. Disconnect wire leads from compressor contactor and condensate pump safety switch.
5. Install new High Pressure Control, reversing the procedure.

*To gain access to compressor and compressor run capacitor, remove left hand side panel.*

# **TROUBLESHOOTING GUIDE**

The following steps and procedures are recommended for correcting the problems indicated. In the event that the problem can not be corrected, service may be required.

## **SERVICE SHOULD BE PERFORMED BY A QUALIFIED AIR CONDITIONING SERVICE TECHNICIAN**

### ***PROBLEM: UNIT DOES NOT POWER UP***

**CAUSE:** Power interruption

**REMEDY:** Check LCDI (if equipped) and reset. Check external power supply making sure that the disconnect is ON. Check for blown fuses or tripped circuit breakers. Reset or replace (as needed).

### ***PROBLEM: NO DISPLAY ON THERMOSTAT AFTER POWER "ON"***

**CAUSE:** Loose display cable, faulty thermostat or faulty power module

**REMEDY:** Check display cable, re-seat connectors. Thermostat may be defective...remove and replace. Power module may be defective...remove and replace.

### ***PROBLEM: EVAPORATOR FAN RUNS BUT COMPRESSOR DOES NOT START***

**CAUSE:** Thermostat — set point is too high.

**REMEDY:** Make sure set-point is lower than room temperature. Look for a red dot to the right of the temperature displayed for cooling.

#### **Note—there is a time delay for the compressor**

**CAUSE:** Thermostat—Loose display cable

**REMEDY:** Examine the thermostat for a loose cable connection. Re-seat the display cable.

**CAUSE:** Condensate Alarm—"CON" is displayed.

**REMEDY:** Check condensate pump and make sure pump is working properly and that there is no kink in the drain line from the pump.

**CAUSE:** High Pressure Cut-Out—"CON" is displayed. Inadequate/turned off condenser water supply.

**REMEDY:** Verify condenser water supply. Check High Pressure Cut-Out Switch. Press Reset (RED Button on back of unit). Re-start unit.

**CAUSE:** Low Voltage — "LAC" is displayed. Check power supply for voltage outside the range of 106-126 volts on the 115 Volt units and 187-253 Volts on the 208/230 Volt units.

**REMEDY:** Have power checked by electrician and repaired.

**CAUSE:** Compressor relay failure.

**REMEDY:** Replace power module.

**CAUSE:** Compressor Contactor failure (3 and 5-ton units)

**REMEDY:** Replace compressor contactor.

# **PREVENTIVE MAINTENANCE**

OWCs are designed to last a long time and to give maximum performance and reliability with minimum maintenance. To prolong the life of the unit, regular maintenance must be performed as specified below:

## **OFF SEASON STORAGE—WINTERIZATION**

Before placing the unit into storage for the off-season, it is recommended to thoroughly clean the unit, and remove all water in the CONDENSER COIL, WATER LINES, DRAIN PAN and CONDENSATE PUMP to avoid damage to the unit from freezing water or contamination.

## **DRAINING THE CONDENSER COIL, AND INTERIOR WATER LINES**

To drain the condenser coil, detach the WATER IN and WATER OUT lines. Using a Shop-Vac or similar device, vacuum the WATER OUT line and start the unit. The water valve will open, allowing you to vacuum the water out of the condenser coil. Eventually, the High Pressure Cut-Out will shut down the compressor. Wait 15 minutes, depress the HI PRESSURE RESET and repeat this process until ALL of the water is out of the system. When completed, depress the HIGH PRESSURE RESET one final time to make sure that it is reset.

## **BLOWER MOTOR**

The evaporator motor on all units have permanently lubricated bearings. No oiling is necessary

## **FILTER**

A clogged filter will cause the unit to operate at greatly reduced efficiencies. We recommend that the filter be inspected on a regular basis (**every six weeks or less**) depending on the environment. The evaporator filter is located behind the return air grille and can be easily removed and cleaned. The filter must be washed periodically as needed by placing it in a dishwasher or soaking in a solution of warm water and detergent for 10 minutes. Then rinsing clean with hot water and shaking excess moisture from filter.

## **DRAINING THE HOSE KIT**

To drain the hose kit, disconnect all hoses, and allow the hoses to gravity drain.

## **EVACUATING THE CONDENSATE PUMP**

Using a Shop-Vac or similar device, vacuum all water out of the condensate pump reservoir. Condensate pumps come standard on all OWC models. When servicing pump, follow these steps:

1. Make certain that the unit is disconnected from the power source before attempting to service or remove any component.
2. Be sure the floats move freely. Clean as necessary.
3. Remove the pump housing and check for obstructions. Clean as needed.
4. Clean the housing with warm water and mild soap when mineral deposits are visible.
5. Check the inlet and outlet piping. Clean as necessary. Be sure there are no kinks in the lines that would inhibit flow.

## **GENERAL**

Oceanaire products are NOT approved for outdoor use. Therefore, off-season storage should be indoor, protected from weather conditions.

When necessary maintenance steps outlined above are followed, the air conditioner will provide long and reliable service. The refrigeration and electrical circuits of the system should only be serviced by a fully qualified service technician.

# PIPING SCHEMATIC

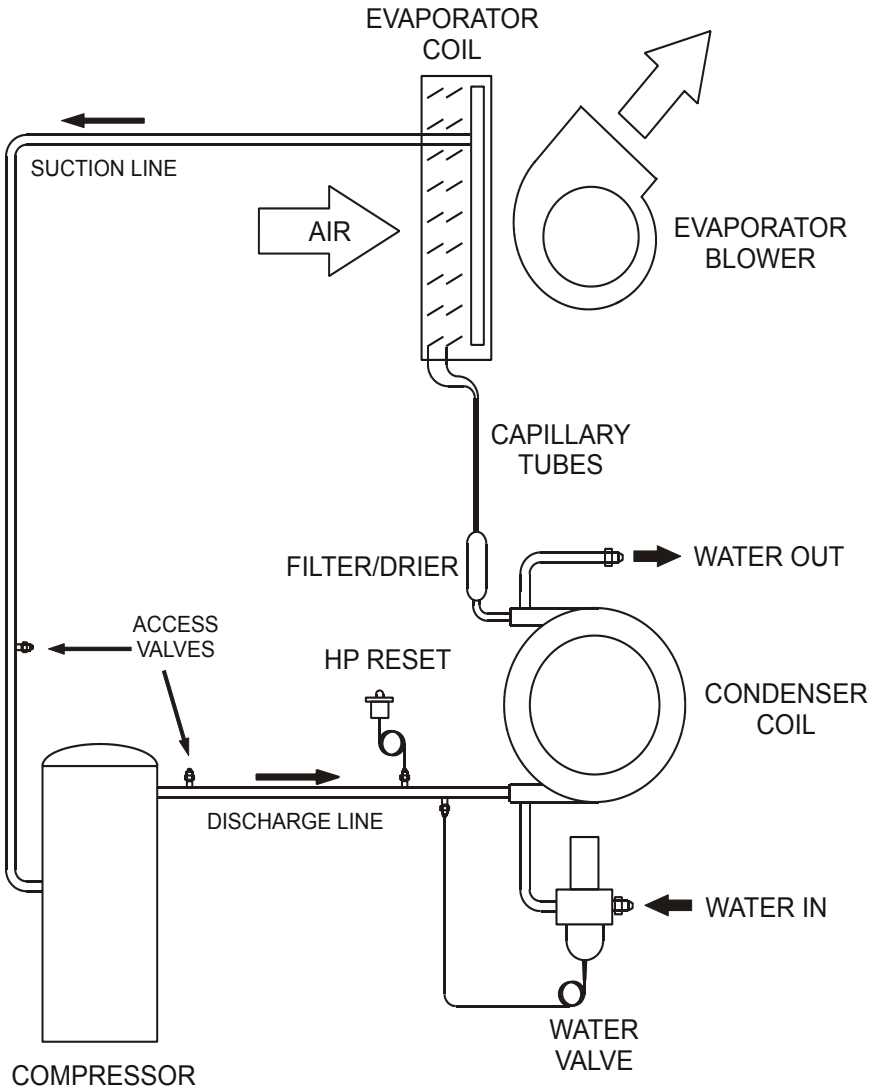

**PIPING SCHEMATIC**  
**Water-Cooled Spot Cooler**

# WIRING SCHEMATIC FOR OWC1211, 1811 and 2412

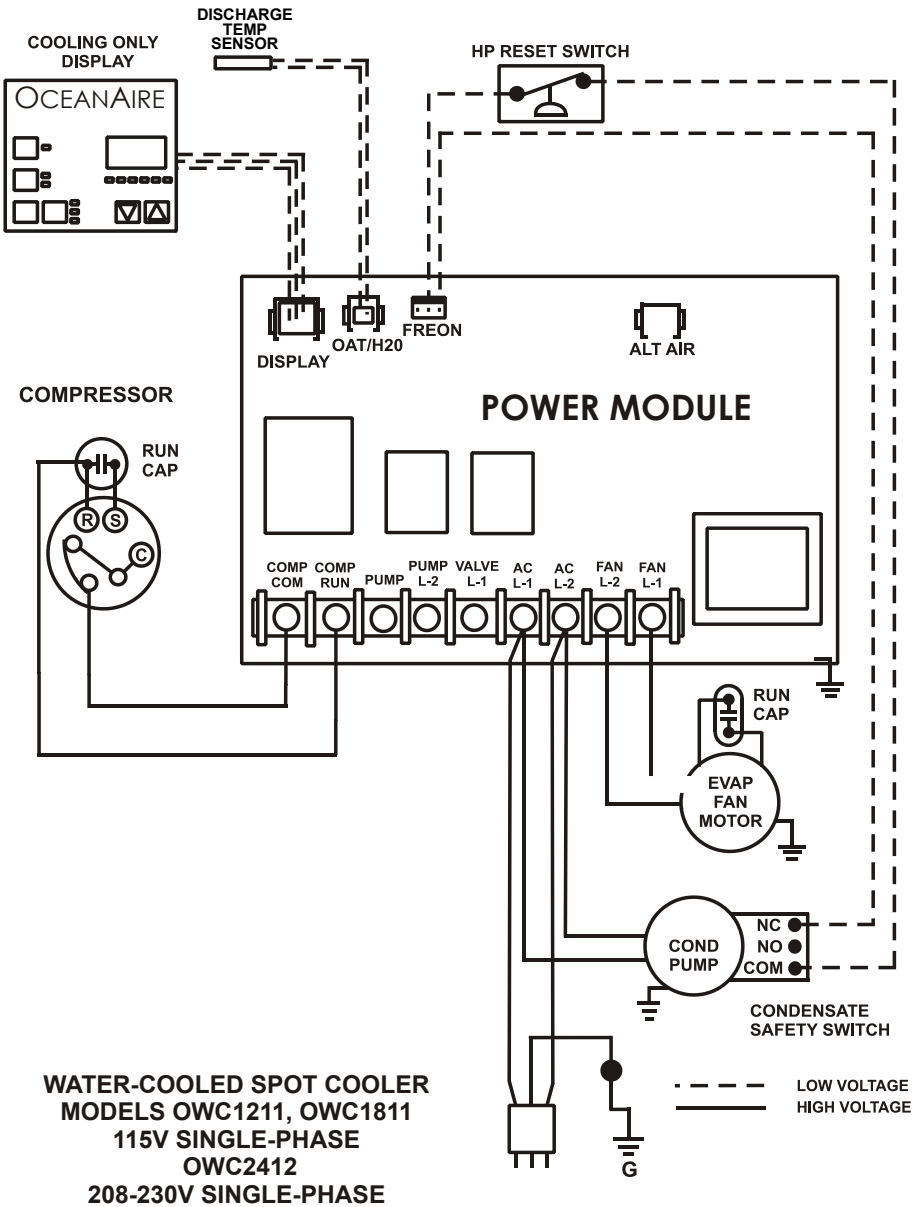



# WIRING SCHEMATIC FOR OWC3612

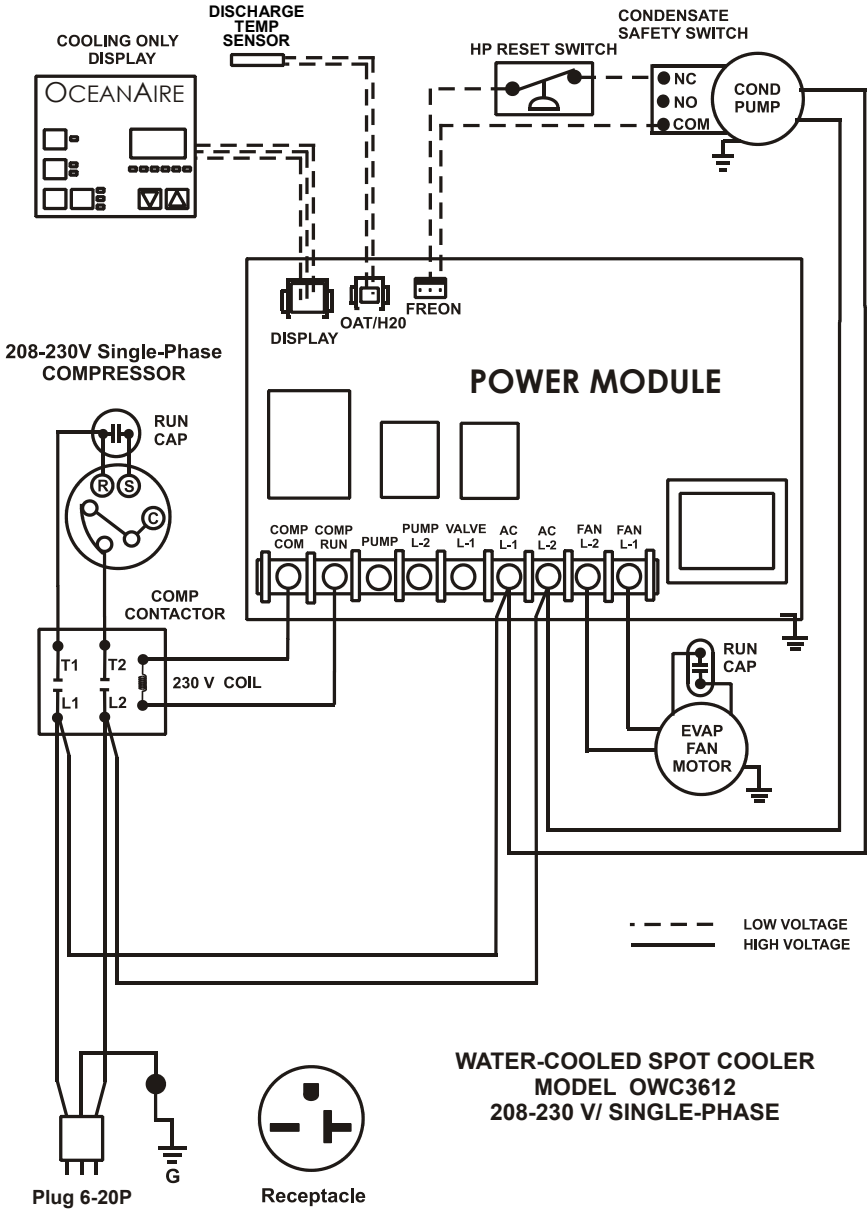

# WIRING SCHEMATIC FOR OWC6012

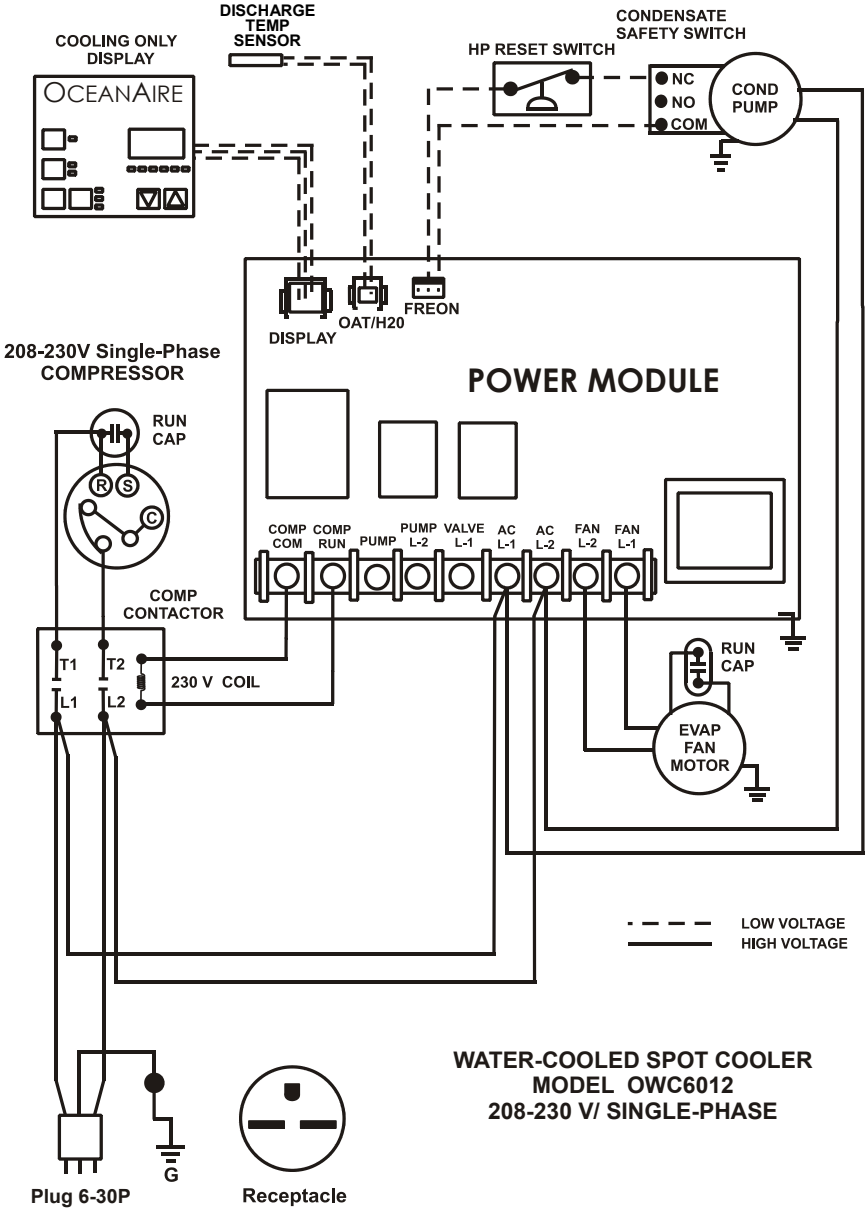

## THREE PHASE MONITOR

Three-Phase units are equipped with monitors for motor protection. The OceanAire Three-phase Monitor safeguards the unit against incorrect compressor rotation, low-voltage and/or loss of power in any one of the power legs. The monitor is installed in the control box and is equipped with an LED for diagnosis of an improper electrical condition (see diagrams below). When power is connected, the compressor WILL NOT engage until the monitor start delay has timed out. If the thermostat does not power up, an electrical condition may need to be addressed. Remove the control box cover and observe the LED on the phase monitor. The LED signals the following:

**GREEN-BLINKING** - Start delay, 120 sec.

**GREEN** - Proper Operation

**RED/GREEN-BLINKING** - signals reverse phase rotation. Switch any two of the power leads for the unit, NOT THE MONITOR LEADS, and re-start.

**RED-BLINKING** - signals improper voltage and/or phase loss. Correct the power problem, then re-start the unit.

In the event of a power interruption, the unit will re-set to a start-up condition. The Phase Monitor will not allow the unit to start until power is corrected.

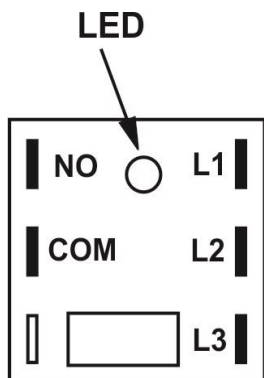

**THREE-PHASE  
MONITOR**

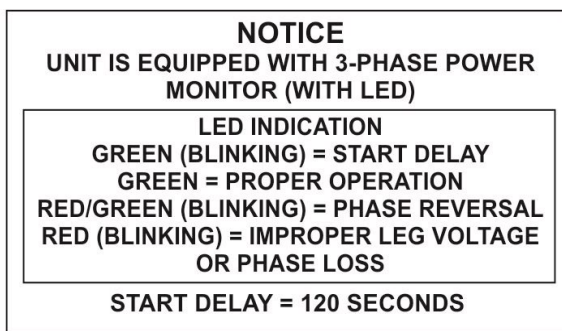

**CONTROL BOX LABEL**

# WIRING SCHEMATIC FOR OWC3632

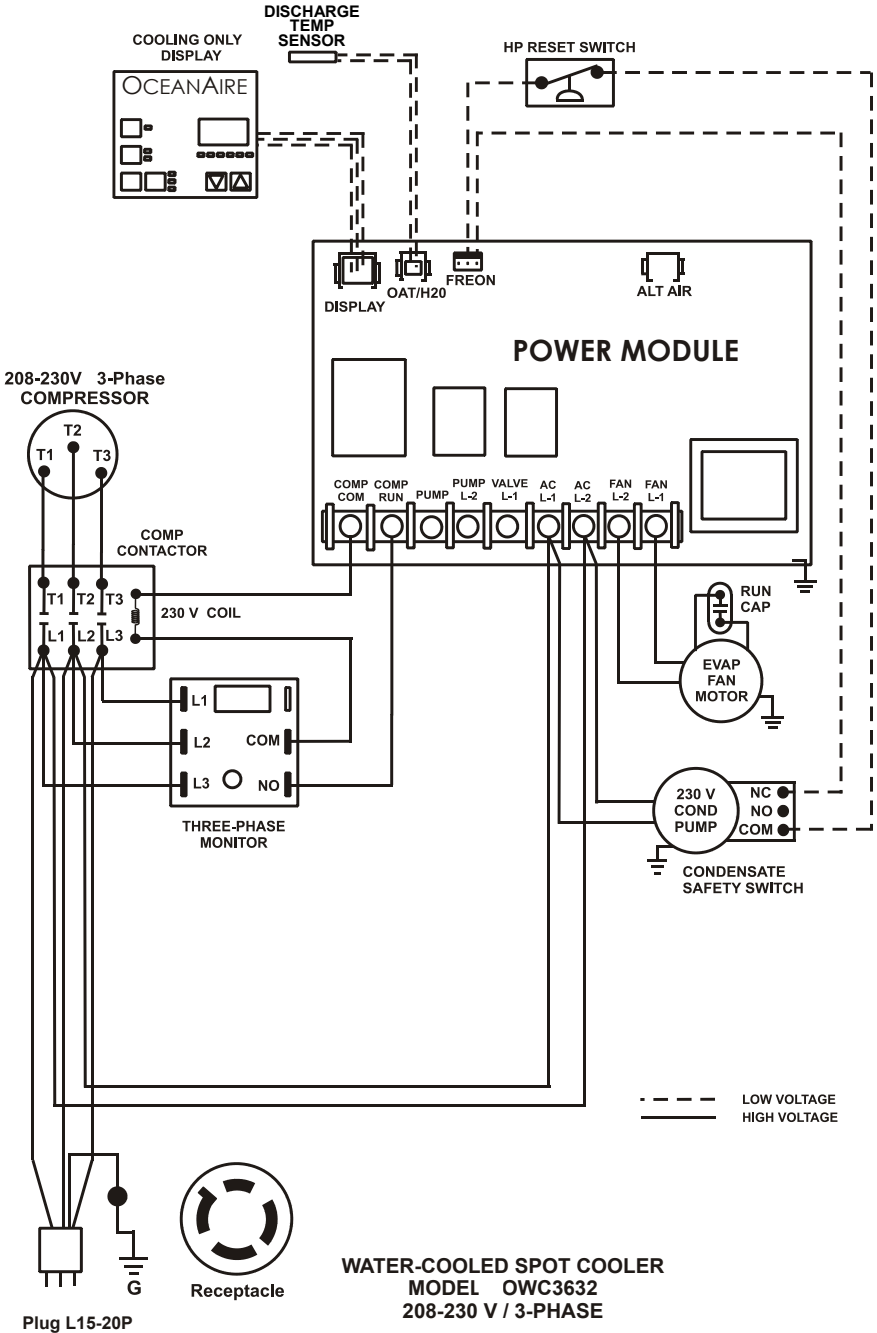

# WIRING SCHEMATIC FOR OWC6032

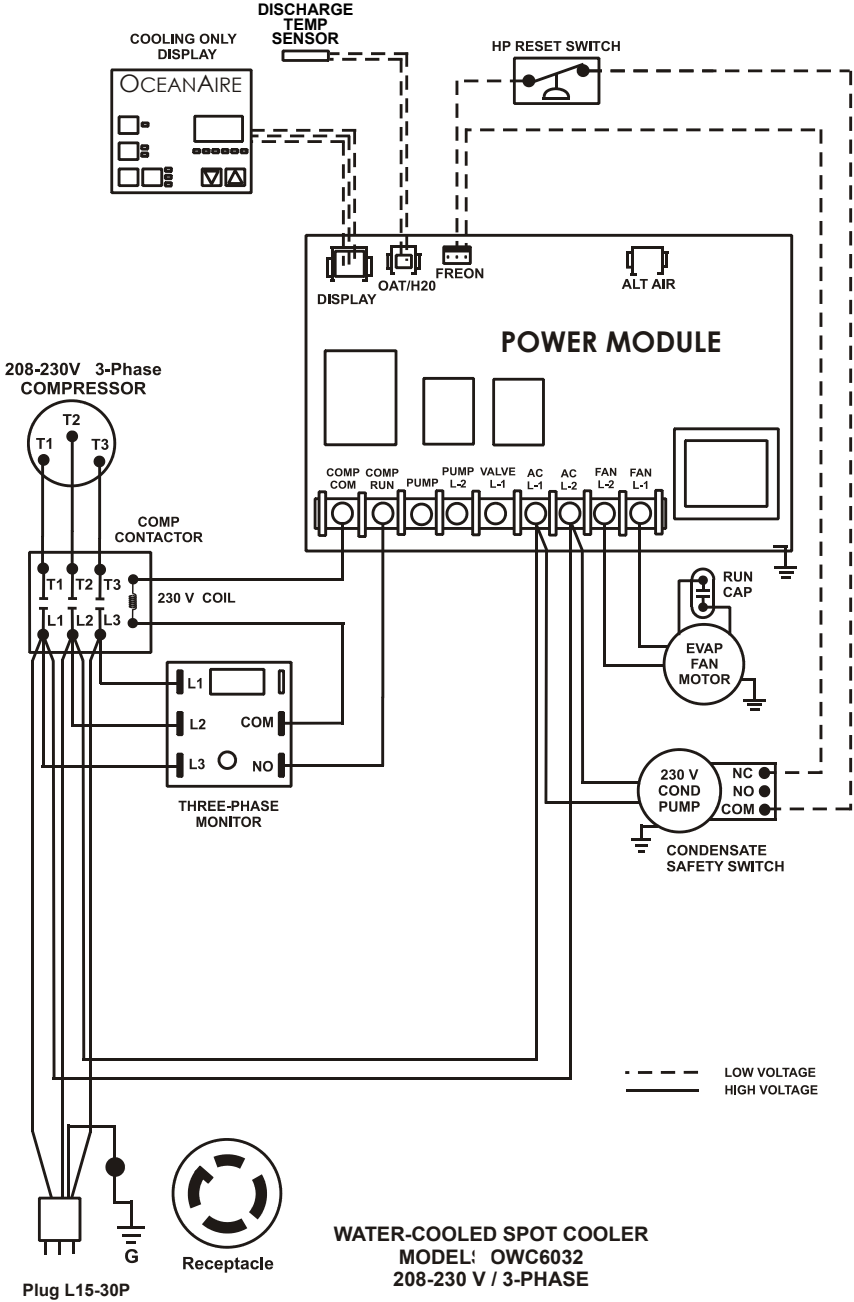

# WIRING SCHEMATIC FOR OWC3634 and 6034

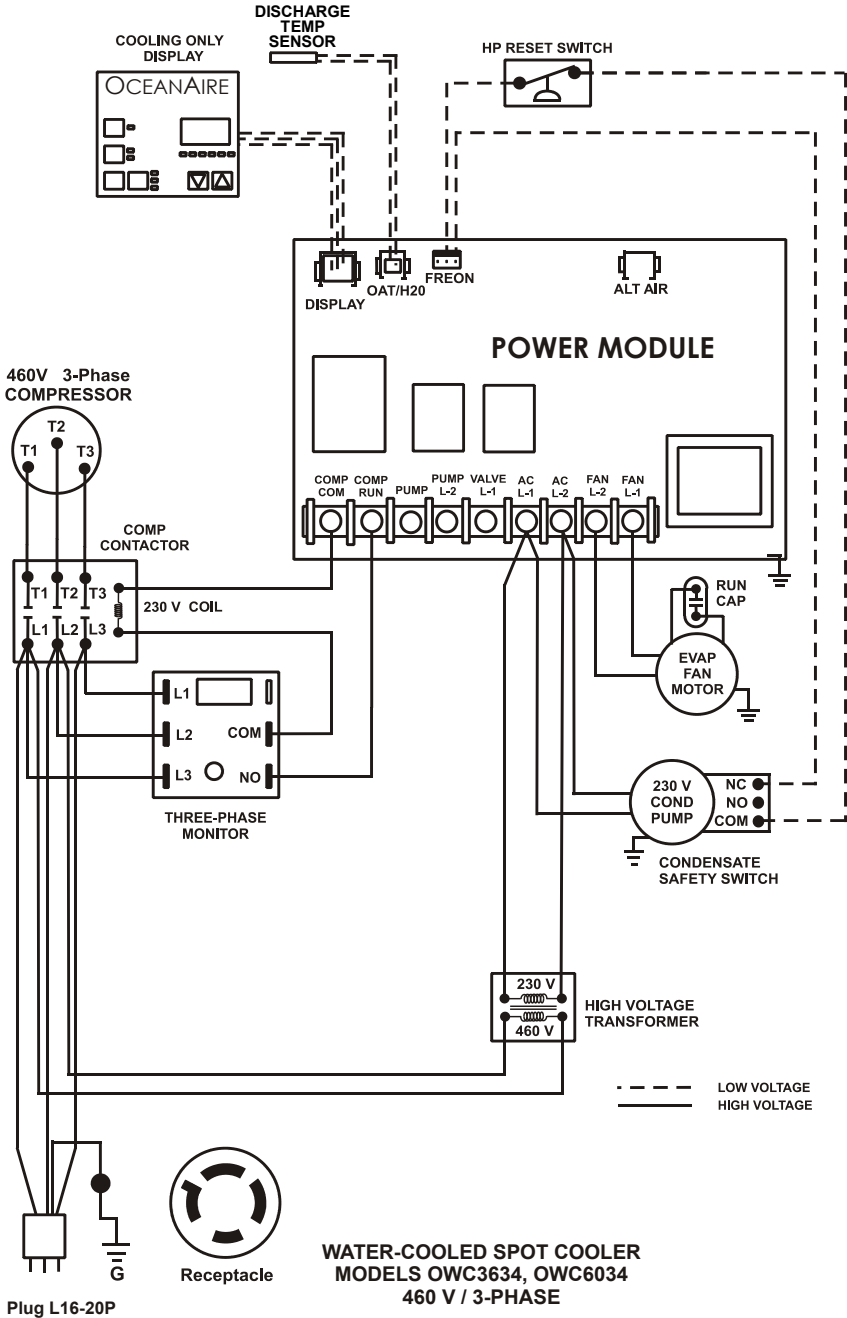

## LIMITED WARRANTY

The Manufacturer (OceanAire, Inc.) warrants to the original owner that the Product will be free from defects in material or workmanship for a period not to exceed one (1) year from date of installation. If upon examination by the Manufacturer, the Product is shown to have a defect in material or workmanship during the warranty period, the Manufacturer will repair or replace, at its option, that part of the Product which is shown to be defective.

The Manufacturer further warrants that the product's compressor-motor will be free from defects in materials and workmanship for five (5) years from the date of installation.

If upon examination by the Manufacturer the Product is shown to have a defect in materials or workmanship during the warranty period, the Manufacturer will repair or replace, at its option, that Part of the Product which is shown to be defective. **Compressor warranty shall be pro-rated for years 2 – 5 at the sole discretion of OceanAire.** Electrical parts such as relays, overloads, capacitors, etc., and the sealed refrigeration system (condenser and evaporator) are included in the one year limited warranty, but not with the five year limited warranty of the compressor.

This limited warranty does not apply to:

- a) Product that has been subjected to misuse or neglect, has been accidentally or intentionally damaged, has not been installed, maintained or operated in accordance with the furnished written instructions, or has been altered or modified in any way.
- b) Product that has been subjected to any abnormal power conditions such as loss of power, power surges, voltage irregularities such as brown-outs or phase loss on three-phase equipment).
- c) any expenses, including labor or material, incurred during removal or reinstallation of the Product.
- d) any workmanship of the installer of the Product.

This limited warranty is conditional upon:

- a) return to the Manufacturer, of the part of the Product thought to be defective.  
Goods can only be returned with prior written approval from the Manufacturer.  
All returns must be freight prepaid.
- b) determination in the reasonable opinion of the Manufacturer, that there exists a defective in material or workmanship.

Repair or replacement of any part under this Limited Warranty shall not extend the duration of the warranty with respect to such repaired or replaced part beyond the stated warranty period.

THIS LIMITED WARRANTY IS IN LIEU OF ALL OTHER WARRANTIES, EITHER EXPRESSED OR IMPLIED, AND ALL SUCH OTHER WARRANTIES, INCLUDING WITHOUT LIMITATION IMPLIED WARRANTIES OF MERCHANTABILITY OR FITNESS FOR A PARTICULAR PURPOSE, ARE HEREBY DISCLAIMED AND EXCLUDED FROM THIS LIMITED WARRANTY. IN NO EVENT SHALL THE MANUFACTURER BE LIABLE IN ANY WAY FOR ANY CONSEQUENTIAL, SPECIAL, OR INCIDENTAL DAMAGES OF ANY NATURE WHATSOEVER, OR FOR ANY AMOUNTS IN EXCESS OF THE SELLING PRICE OF THE PRODUCT OR ANY PARTS THEREOF FOUND TO BE DEFECTIVE. THIS LIMITED WARRANTY GIVES THE ORIGINAL OWNER OF THE PRODUCT SPECIFIC LEGAL RIGHTS. YOU MAY ALSO HAVE OTHER RIGHTS WHICH MAY VARY BY EACH JURISDICTION.

# END USER INFORMATION

MODEL: \_\_\_\_\_

SERIAL NUMBER: \_\_\_\_\_

DATE PURCHASED: \_\_\_\_\_

INSTALLED BY: \_\_\_\_\_

DATE INSTALLED: \_\_\_\_\_

For Technical Support, or to locate a distributor for service parts, contact OceanAire at (847) 583-0311 or 1-866-GETAIRE (438-2473). Please indicate the Model Number and Serial Number of the unit to assure proper information and service parts.

## TECH NOTES

---

---

---

---

---

---

---

---

---

---



OCEANAIRE

6228 Oakton Street Morton Grove, IL. 60053  
1-866-GET-AIRE (438-2473) Phone: (847) 583-0311 Fax: (847) 583-0312  
web-site: [www.oceanair-inc.com](http://www.oceanair-inc.com) e-mail: [sales@oceanair-inc.com](mailto:sales@oceanair-inc.com)