

Portable Air Conditioner and Heat Pump - Air Cooled

MODEL: 2OACH	1211	1811	2412	3612	3632	3634	6012	6032	6034
Cooling Capacity	11,800	16,800	24,020	36,050	36,050	36,050	60,100	60,100	60,100
Heating Capacity	11,000	15,600	22,000	32,500	32,500	32,500	53,500	53,500	53,500
Voltage (V/Phase) at 60Hz	115/1		208-230/1	208-230/1	208-230/3		208-230/1	208-230/3	
Amps	10.4	14.1	14.9	18.1	17.2	8.7	32.0	20.4	14.8
Watts	1180	1670	2700	3620	3620	3620	6000	6000	6000
In Rush Current (Amps)	60	75	68	113	93	60	178	162	87
Plug Type	5-15P	5-20P	6-20P	6-30P	L15-30P	L16-20P	6-50P	L15-30P	L16-20P
EER	10.0	10.0	8.9	10.0	10.0	10.0	10.0	10.0	10.0
Compressor HP	1	1 1/2	2	3	3	3	5	5	5
Compressor RLA	9.5	12.3	10.5	13.6	8.8	5.0	27.6	18.1	9.0
Compressor LRA	50	63	48	83	77	35	158	137	62
Evap CFM	400	600	810	1200	1200	1200	1950	1950	1950
Evap Motor HP	1/8	1/8	1/3	1/3	1/3	1/3	1	1	1
Evap Motor Watts	180	210	370	420	420	420	700	700	700
Condenser CFM	580	930	1010	1390	1390	1390	2200	2200	2200
Condenser Motor HP	1/8	1/8	1/3	1	1	1	1	1	1
Condenser Motor Watts	200	280	490	860	860	860	1100	1100	1100
Condensate	5 Gallon Condensate Tank - STANDARD (Pump Optional)					Pump -STANDARD (20 ft. Lift)			
Sound Level	54	60	65	69			78		
R-410A Charge Oz.	18	40	37	66			80		
(A) Height with Casters (in.)	37-3/4	45-3/4		50-1/4			51-3/4		
(B) Width (in.)	20	24		27-1/2					
(C) Depth (in.)	25	30		35			39-1/2		
(D) Height w/o Casters (in.)	32-1/2	40-1/2		45			45-1/2		
Net Weight (lb.)	180	260	260	365		380	485	485	515
Shipping Weight (lb.)	200	285	285	405		420	525	525	555
Shipping Volume (cu. ft.)	19	28		40			48		



HEATING & COOLING



SPECIFICATIONS SUBJECT TO CHANGE WITHOUT NOTICE

- OA **Cooling Capacity** is total BTUH at 80°DB/67°WB return air, 95°F Outdoor
- OA **Heating Capacity** is total BTUH at 70°DB/60°WB indoor, 47°DB/43°WB Outdoor
- OA Time Delay fuses/circuit breakers are recommended
- OA EER is determined at high fan speed, with condenser discharge air ducted into another area
- OA CFM with free discharge
- OA Models 2OACH60 and 2OACH36 are shipped with 16-inch Condenser Duct Flange installed
- OA Condensate pumps are installed in 2OACH60 Models

Cooling Ambient Operating Range 65° To 105°

Heating Ambient Operating Range 40° To 85°

NOT APPROVED FOR OUTDOOR USE

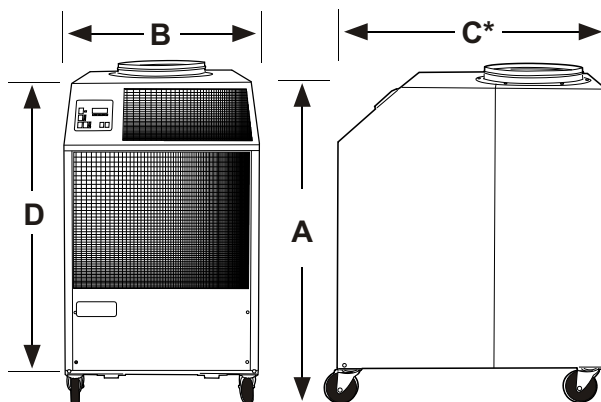

* Condenser Return Air Plenums
2DCP-1 and 2DCP-2 add 13 inches to "C"
DCP-5 adds 17 inches to "C"

WARRANTY

ALL OCEANAIRE PRODUCTS ARE COVERED BY THE OCEANAIRE LIMITED WARRANTY

1 YEAR ON THE FULL PRODUCT PLUS, 4 ADDITIONAL YEARS FOR THE COMPRESSOR (RESTRICTIONS APPLY)

FEATURES

- OA AUTOMATIC MODE CHANGEOVER
- OA MANUAL OR AUTO 6-SPEED AND CONTROL
- OA LARGE LED DISPLAY
- OA REAR SWIVEL BALL BEARING CASTERS
- OA LOCKING FRONT CASTERS
- OA CONDENSATE OVERFLOW ALERT
- OA LCDI POWER CORD (1-3 ton units/single phase)
- OA HIGH PRESSURE SAFETY SWITCH
- OA WASHABLE ELECTROSTATIC AIR FILTERS

NOZZLE KIT

2NK-1	2 X 4-INCH NOZZLES	2OACH12
2NK-2	2 X 6-INCH NOZZLES	2OACH18, 24
2NK-3	2 X 8-INCH NOZZLES	2OACH36, 60

CEILING PANEL KIT

CK-12	12-INCH	2OACH12, 18, 24
CK-16	16-INCH	2OACH36, 60
CK-12PL	CK-12 WITHOUT DUCT FLANGE	

CONDENSATE PUMP KIT

2DPC-1	115V PUMP KIT, DELUXE	2OACH12, 18
2DPC-2	230V PUMP KIT, DELUXE	2OACH24, 36

(Condensate pumps are installed in 2OACH60 models)

EVAPORATOR RETURN AIR PLENUM KIT

DEP-10	10-INCH	2OACH12
2DEP-12	12-INCH	2OACH18, 24
DEP-16	16-INCH	2OACH36, 60

DISCHARGE DUCT ADAPTER

2DDA-6	6-INCH	2OACH12
2DDA-10	10-INCH	2OACH18, 24
2DDA-16	16-INCH	2OACH36, 60

CONDENSER RETURN AIR PLENUM

2DCP-1	12-INCH	2OACH12
2DCP-2	12-INCH	2OACH18, 24
DCP-5	16-INCH	2OACH36, 60

CEILING PANELS (PANEL WITH DUCT CONNECTOR)

CKP-12	2 X 2 CEILING PANEL, FOR 12-INCH DUCT	
CKP-16	2 X 2 CEILING PANEL, FOR 16-INCH DUCT	

DUCT FLANGE

DF-12	12-INCH DUCT FLANGE	2OACH12, 18, 24
DF-16	16-INCH DUCT FLANGE	2OACH36, 60

(2OACH36 and 2OACH60 are shipped with 16" duct flange)

