



Controlling Your Comfort Room by Room

# ZONE DAMPER

With MP12M Plug-In Motor  
**Model: ZDSP & ZDBP**

The ZD series are extruded aluminum parallel blade dampers compete with a Power Open Power Close Plug-In Motor. These dampers are shipped complete and ready for installation. The lightweight ZD can be installed in any position in any properly sized duct. These dampers are rated for duct pressure up to 2.0" W.C.

Dampers are available all in even sizes from 8"x8" to 36"x24". All dampers are 1/4" undersized from their listed size. Dampers are ordered as ZDSP for side mount, width by height, as the motor and end plate will be on the smaller dimension, for typical insertion into the side/shorter dimension of the duct. The ZDBP denotes bottom mount and is ordered height by width. The motor and end plate are on the longer dimension for typical insertion into either the bottom or top of the duct. Dampers are ordered as ZDSPwwhh or ZDBPhhww, using 2 digits for each dimension. All ZD dampers are shipped in the Open position ready for installation.

A 12 Volt DC damper motor, Model MP12M, powers the damper closed and open. The MP12M motor wires by simply plugging the motor in using the modular cord, supplied with each damper. The modular cord is a 25' length of standard four (4) conductor telephone wire with RJ11 jacks on each end. The motor is complete with 2 jacks allowing you to daisy chain up to 10 dampers per zone.

The MP12M motor has been tested to over 1,000,000 cycles to provide long life. Even replacing the motor is a simple less than one (1) minute change by loosening the setscrew holding the motor onto the damper, slide the motor off the damper shaft, place a new one on and secure with the screw.

The MP12M motor also has a two-color Light Emitting Diode (LED) to indicate the damper position. When the LED is **GREEN** the damper is **Open**. When the LED is **RED** the damper is **Closed**. When the LED is not lit the motor is typically moving between open and closed. The motor cycles between open and closed in less than 5 seconds



**ZDSP Side Mount**

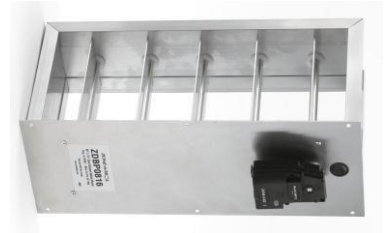

**ZDBP-Bottom Mount**

### Dimensional Drawing (nominal)

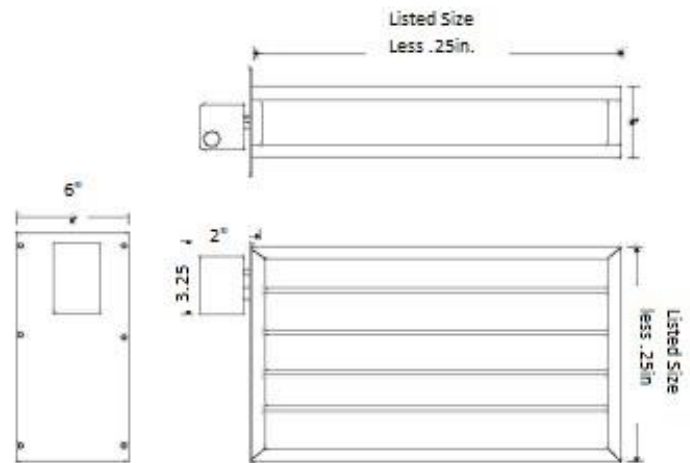

### Damper Specifications

Construction – Aluminum Mill Finish, Mitre Angles  
 Linkage – Zinc plated linkage arms, Delrin bushings  
 Dimensions – 8"x8" to 36"x24" in 2" increments, 1/4" undersized.

Custom sizes also available

Motor Voltage – 12VDC, 0.100A  
 Torque – 7.0 in/lbs, 112.0 in/oz, 0.79NM  
 Temperature Rating - 0°F to 150°F Operating, -13°F to 150°F Storage  
 Humidity – 5% to 95% Non-Condensing  
 Damper Timing – Nominal 5 Sec. Powered Open-Closed \  
 Connection - Modular RJ11, 2 Ports  
 Duct Pressure – Maximum 2"W.C.



Actuator & 25' of modular cord included with each damper

### Minimum Position Adjustment

Simply open the cover to minimum position setting. With a screwdriver, loosen the setscrew and adjust your setting to desired position.



## INSTALLATION

1. Cut a 4-inch (102-millimeter) opening in one side of the air duct at the location selected. Ensure the opening is cut fully to the top and bottom air duct seams.
2. Slide the damper into the cut opening of the air duct. Ensure the electric actuator is mounted toward the top of the air duct.
3. Secure the damper mounting plate to the air duct with the sheet metal zip screws provided.

Side Mount:

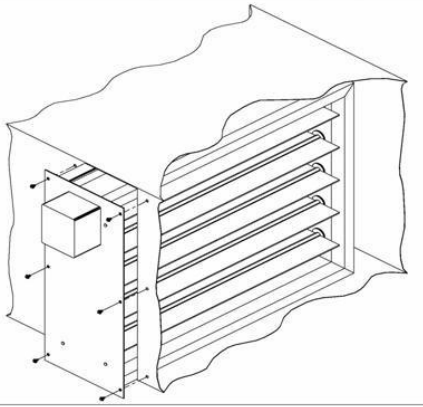

Bottom Mount:

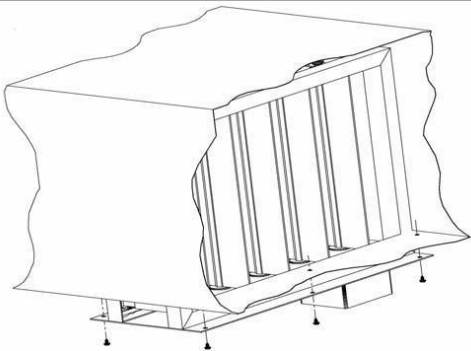

## CHECKOUT

To checkout the operation of the dampers the control panel needs to be operating. It is recommended that each damper be checked before installing into the duct.

To check the damper, plug the damper into a zone on the control panel. Each zone of the panel has an LED that will be **Green** when the damper is to be **open**. When the panel LED is off, the damper will **close** and the damper LED will turn **RED**.

All dampers are 100% factory tested with the cord provided with each damper.

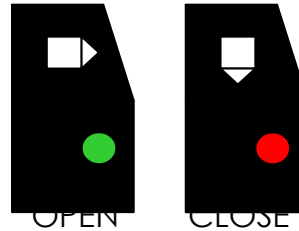

The damper shaft is square however the motor has a small triangular shape that also indicates the position of the damper. If the LED does not light, this will indicate the damper is either opening or closing. The damper may be closed and the LED not lit Red as the damper may have stopped short of full closed due to the roundness of the damper.

## TROUBLESHOOTING

If the damper LED does not light and the motor is not moving when plugged into the control panel, unplug and retry plugging in again. Until the motor moves and the LED lights. Make sure the cord is not pinched or broken.

The motor is powered by 12VDC from the panel. Check the connector on the panel for 12VDC as shown below.

