

Round Double Deflection Grille - Round Reducer Series

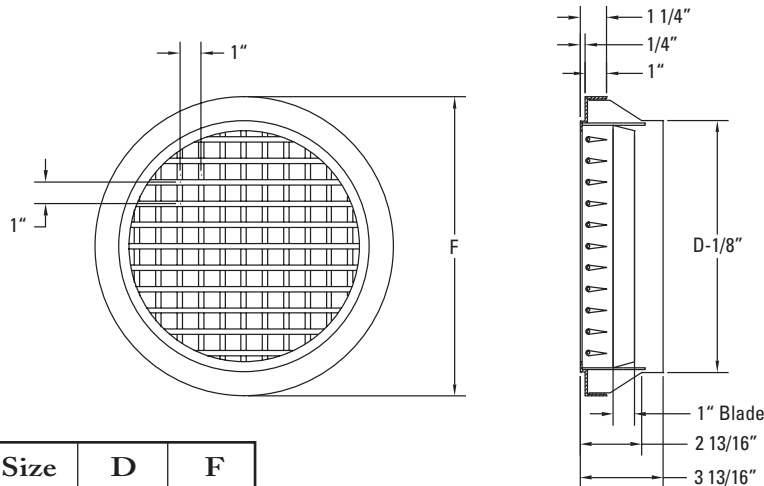

Model	Size	D	F
RDD-06-RR	6	6	8-1/4
RDD-08-RR	8	8	10-1/4
RDD-10-RR	10	10	12-1/4
RDD-12-RR	12	12	14-1/4
RDD-14-RR	14	14	16-1/4
RDD-16-RR	16	16	18-1/4
RDD-18-RR	18	18	20-1/4
RDD-20-RR	20	20	22-1/4
RDD-22-RR	22	22	24-1/4
RDD-24-RR	24	24	26-1/4

Inches measured to the nearest 1/16 inch

HIGH VELOCITY AIR OUTLET

- Double Deflection Design
Adjustable Vertical and Horizontal Blades
- Adjustable Air Pattern
Long Air Throws
Wide Dispersion Patterns
- 1" Extruded Airfoil Blades / 1" Spacing
- Mounts Cleanly to Exposed Ductwork

STANDARD FINISH:

- #52 White Powder Coat
- #42 Gloss Black Powder Coat
- #72 Silver Metallic Powder Coat
- #00 Mill Aluminum

MATERIAL:

- Heavy Gauge Aluminum Construction
- 1" Extruded Airfoil Blades / 1" Spacing

OPTIONS:

- Custom Finish _____

NOTES:

- Frame Slides Cleanly Into End of Exposed Ductwork
- Mounting Screws Included

Project:	<h2>RDD Series</h2> <p>Round Double Deflection Grille -Round Reducer Series</p>	
Architect:		
Engineer:		
Contractor:	Form No: 10014S	
Submitted By:	Date:	Drawn By: MH June 2004