

**Efficient**

**Durable**

**True  
Redundancy**

**Service  
Friendly**

**Reliable**

**Maneuverable**

**Environmentally  
Friendly**



## Water Cooled Modular Chiller

UCW/H Series

15, 25, 30, 50, 70 and 85 Tons – Configurable up to 1,000 Tons  
Available in 208, 230, 460 and 575 Volts

**CLIMA  COOL<sup>®</sup>**

THE ULTIMATE CHILLER SOLUTION<sup>®</sup>



## Major application flexibility and expandability.

A dedication to energy and environmental leadership results in the Ultimate Chiller Solution modular design and fundamental features: compact size, redundant operation, maneuverability, efficiency, reliability and serviceability. Available in 15, 25, 30, 50, 70 and 85 tons which, when combined, tonnages can obtain specific project turndown and capacity requirements from 15 to 1,000 tons per bank while having the ability to accommodate future growth and expansion needs.

**Durable** Heavy gauge G90 galvanized steel base and framework with 3 mil powder coat paint finish, baked at 350°F for resilience in transport and installation. Schedule 40 carbon steel pipe water headers are designed to connect to adjacent modules through the use of 300 psi rated grooved couplings.

**Energy Efficient** High efficiency design offers up to 16.5 EER at full-load and up to 21.3 EER at part-load (IPLV), exceeding ASHRAE 90.1 minimum efficiency requirements.

**Environmentally Friendly** Incremental and minimum overall per ton refrigerant charge. Largest refrigerant circuit contains approximately one pound per ton of charge per module. This typically eliminates the requirement for expensive refrigerant monitoring, ventilation and associated controls. Non-ozone depleting R-410A refrigerant offers better efficiency, higher capacity and utilizes superior synthetic lubricants for longer compressor life.

**Integrated CoolLogic Control System** Each module has an independent control panel and simple two-conductor shielded daisy chain connection from the Master Panel to the modules ensuring ultimate performance with minimal field wiring. BAS interface with native BACnet, Modbus, Lonworks and N2 communications.

**Maneuverable** All modules fit easily through standard 36" doorways and onto typical freight elevators. Modules are designed with a low center of gravity and base cutouts for forklifts and pallet jacks.

**Reliable** Dual scroll compressors with independent refrigerant circuits provide reliable, efficient, quiet and redundant operation. Use of highly efficient, dual circuit brazed plate heat exchangers offer maximum performance at both full-load and part-load conditions.

**Service Friendly** Design allows easy access to major components such as compressors, brazed plate heat exchangers, refrigeration components and pete's ports. Unique design is fully serviceable and maintainable without removal of module from the chiller bank or disassembly of headers.

**True Redundancy** Separate module electrical feeds provide true electrical redundancy. Dual independent refrigeration circuits per module provide true mechanical redundancy.



Photo shows three 70 ton modules totaling 210 tons capacity. The 15, 25, 30, 50 and 70 ton modules are configurable up to 400 tons per bank. The 85 ton module is configurable up to 1,000 tons per bank.



## Options for every application.

**Automatic Strainer Package** Field installed high quality stainless steel filtration system with minimum 60 mesh stainless steel screens. Available options include pressure differential alarm and automatic time flush.

**Condenser Water Head Pressure Regulating Control** Factory installed motorized condenser water valves provide head pressure regulation for low entering condenser water temperature applications (less than 60°F).

**Heat Pump** Factory installed reverse cycle heating and cooling operation compatible with boiler/tower and geothermal systems.

**Heat Recovery** Factory installed option that provides hot water, as high as 135°F, while simultaneously producing chilled water for the chiller system.

**Hot Gas Bypass** Factory installed on both circuits allowing unit operation below the minimum step of unloading.

**Manual Strainers** Field installed to increase efficiency and ensure long life of the equipment with Y-style and basket strainers of cast iron 200 psi or carbon 275 psi with 60 mesh stainless steel screens. All strainers are field installed external to the chiller bank for ease of service.

**Pressure Differential Flow Sensor** Field installed to prevent operation of the chiller without sufficient water flow to the evaporator and/or condenser.

**Variable Speed Compressor** Factory installed variable frequency drives provide more precise water temperature control and optimum part load energy efficiency.

**Water Header Bypass** A field installed water header bypass may be utilized to prevent deadheading the pump.

**Water Isolation Valves and Flush Ports** Factory installed to provide isolation to the module for maintenance and cleaning of evaporator and condenser heat exchangers. This is accomplished without increasing unit or bank dimensions while adjacent modules continue normal operation. Optional choice of integral manual or motorized valves includes ¾" fill and flush valves.

## LEED categories satisfied by the UCW/H system:

**Enhanced Commissioning and Measurement and Verification** *CoolLogic* Control System provides maximum flexibility with BAS interface.

**Enhanced Refrigerant Management** Micro charge of chlorine-free and non-ozone depleting refrigerant.

**Optimized Energy Performance** Exceeds ASHRAE 90.1 minimum efficiency.

**Sustainable Sites and Building Re-Use** Compact design shrinks mechanical room and building footprint and allows modules to fit through existing doors. This eliminates the need for demolition and reconstruction.

**Thermal Comfort** Precise required heating and cooling ensures the highest comfort for building occupants.

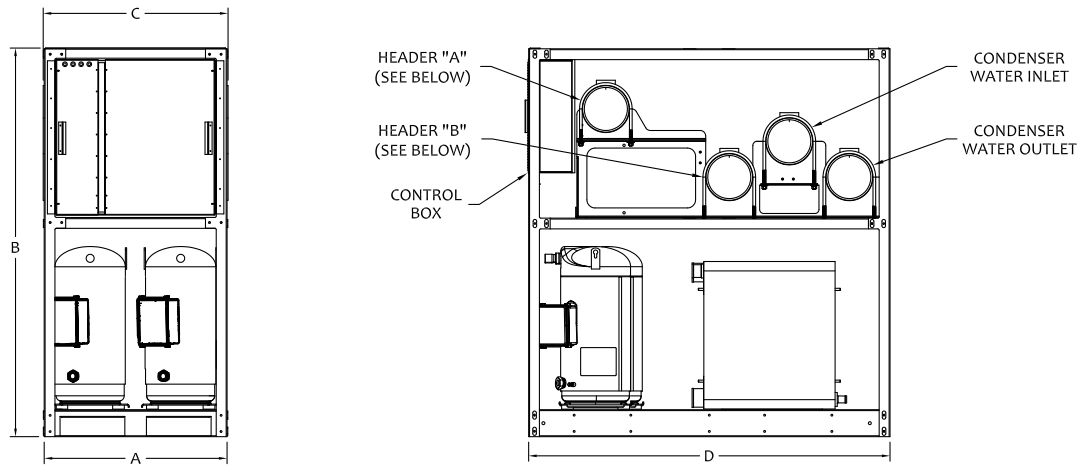

Load Water Piping Configuration Arrangement (Header "A")								
UCW		UCH Heat Recovery		UCH Heat Pump (Cooling Priority)		UCH Heat Pump (Heating Priority)		
Chilled Water Outlet		Chilled Water Outlet		Load Water Outlet		Load Water Inlet		
Load Water Piping Configuration Arrangement (Header "B")								
UCW		UCH Heat Recovery		UCH Heat Pump (Cooling Priority)		UCH Heat Pump (Heating Priority)		
Chilled Water Inlet		Chilled Water Inlet		Load Water Inlet		Load Water Outlet		
Model UCW/H	Voltage	A Unit Width (in.)	B Unit Height (in.)	C Header Width (in.)	D Unit Depth (in.)	Unit Weight <sup>1</sup> (lb.)	Operating Weight <sup>2</sup> (lb.)	Header Connection (in.) <sup>3</sup>
015	208/230/460/575/3/60	34	65 1/8	34 1/4	55 1/2	1,290	1,480	6
025	208/230/460/575/3/60	34	65 1/8	34 1/4	55 1/2	1,290	1,480	6
030	208/230/460/575/3/60	34	65 1/8	34 1/4	55 1/2	1,375	1,565	6
050	208/230/460/575/3/60	34	65 1/8	34 1/4	55 1/2	2,085	2,405	6
070	208/230/460/575/3/60	34	65 1/8	34 1/4	55 1/2	2,195	2,515	6
085	208/230/460/575/3/60	34	72	34 1/4	67	2,610	3,075	8

**Notes:**

- Shipping weight includes refrigerant charge, compressor oil and packaging.
- Operational weight includes refrigerant charge, compressor oil and water.
- Model UCW/H 085 cannot be directly coupled with models UCW/H 015, 025, 030, 050 or 070 due to differences in header and frame size.

Contact your local ClimaCool representative or visit our web site at [www.climacoolcorp.com](http://www.climacoolcorp.com) to find out more about the UCW/H and other heating and cooling solutions that may fit your application needs.



15 S. Virginia  
 Oklahoma City, OK 73106  
 Phone: 405.815.3000  
 Fax: 405.815.3052  
[www.climacoolcorp.com](http://www.climacoolcorp.com)



ClimaCool works continually to improve its products. As a result, the design and specifications of each product at the time for order may be changed without notice and may not be as described herein. Please contact ClimaCool's Customer Service Department at 405.815.3000 for specific information on the current design and specifications. Statements and other information contained herein are not express warranties and do not form the basis of any bargain between the parties, but are merely ClimaCool's opinion or commendation of its products.

AHRI Certified® is a trademark of the Air Conditioning, Heating, and Refrigeration Institute. 'USGBC®' and related logo is a trademark owned by the U.S. Green Building Council® and is used with permission.