

## Aluminum Punkah Louver -Diffusing Series

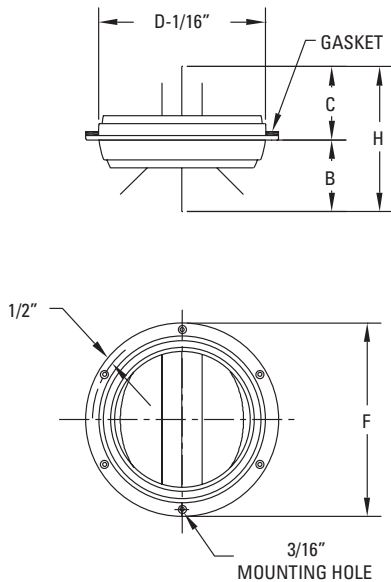

### HIGH VELOCITY TASK AIR OUTLET

- Low Noise Levels
- Low Pressure Requirements

### ADJUSTABILITY

- Easy Finger Tip Adjustment
- Directional Air Pattern Control:  
*70 Degree Global Rotation Minimum*  
*±35 Degree Deflection*  
*360 Degree Rotation*
- The Spherical Core Can Be Easily Adjusted To Provide a Jet Air Pattern or Diffused Air Pattern.

MODEL	SIZE	B	C	D	F	H	Mtg Holes
APLD-08	8	3-5/8	3-5/8	8	10	7-1/4	4
APLD-10	10	4-5/8	4-5/8	10	12	9-1/4	6
APLD-12	12	5-3/8	5-3/8	12	14	10-3/4	6

Inches measured to the nearest 1/16 inch

### STANDARD FINISH:

- #12 Anodized Aluminum Powder Coat
- #42 Gloss Black Powder Coat
- #52 White Powder Coat
- #72 Silver Metallic Powder Coat
- #00 Mill Aluminum

### OPTIONS:

- Custom Finish \_\_\_\_\_

### MATERIAL:

- Aluminum
- Foam Gasket

### NOTES:

- Mounting Screws Included
- US Patent Pending

<b>Project:</b>	<h2>APLD Series</h2> <p>Aluminum Punkah Louver - Diffusing Series</p>	
<b>Architect:</b>		
<b>Engineer:</b>		
<b>Contractor:</b>	<b>Form No: 20030S</b>	
<b>Submitted By:</b>	<b>Date:</b>	<b>Drawn By: MH January 2005</b>