

EZ Fastener Installation-Requires access behind mounting surface

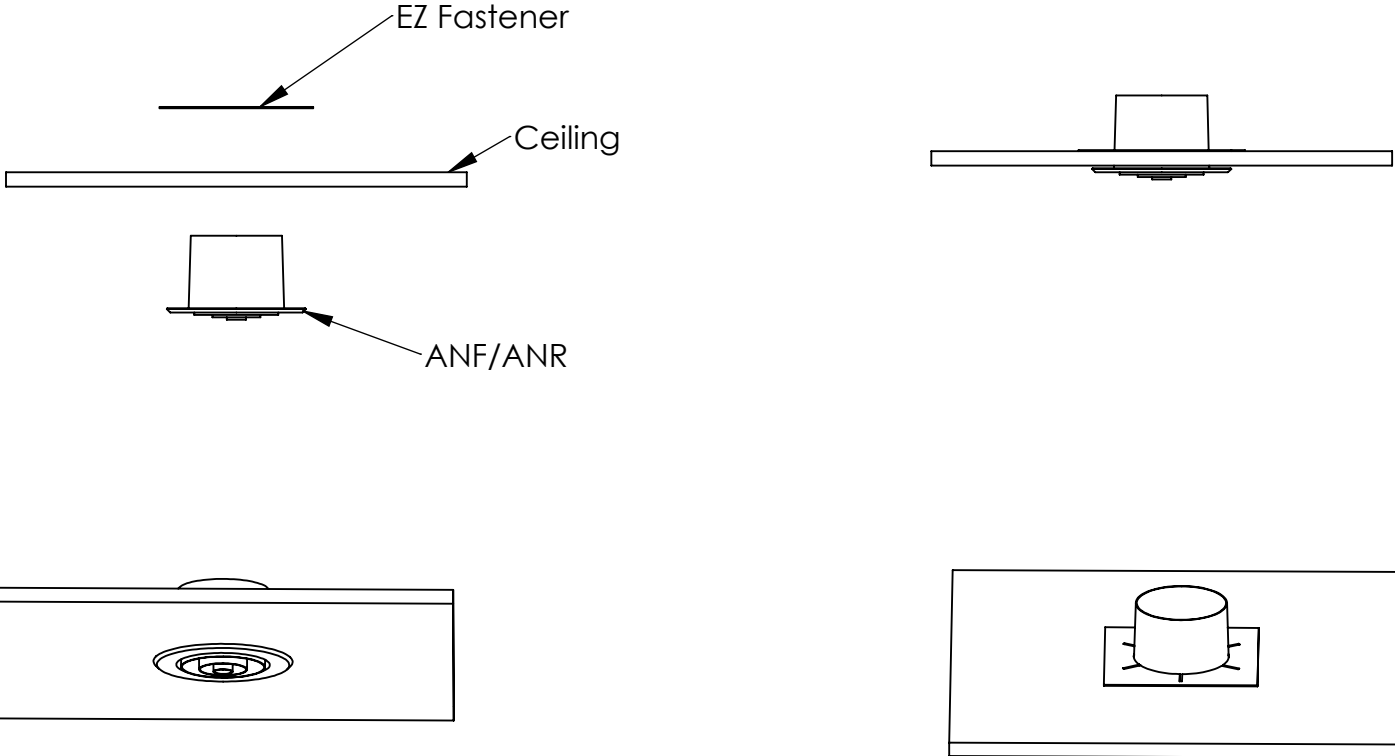

**Note: Standard on sizes 3"-5"
Mount with provided concealed EZ Fastener
Optional on sizes 6"-24"**

PROPRIETARY AND CONFIDENTIAL
THE INFORMATION CONTAINED IN THIS DRAWING IS THE SOLE PROPERTY OF AIRCONCEPTS, INC. ANY REPRODUCTION IN PART OR AS A WHOLE WITHOUT THE WRITTEN PERMISSION OF AIRCONCEPTS, INC IS PROHIBITED.

		UNLESS OTHERWISE SPECIFIED:		NAME	DATE
		DIMENSIONS ARE IN INCHES TOLERANCES: ± 1/32" FRACTIONAL ANGULAR: MACH ± BEND ± TWO PLACE DECIMAL ± THREE PLACE DECIMAL ±	DRAWN	M.H.	06-03-10
		INTERPRET GEOMETRIC TOLERANCING PER:	CHECKED		
		MATERIAL	ENG APPR.		
		FINISH	MFG APPR.		
NEXT ASSY	USED ON		Q.A.		
APPLICATION		DO NOT SCALE DRAWING			



ANF/ANR Installation Instruction

SIZE	DWG. NO.	REV
A		
SCALE: 1:10	WEIGHT:	SHEET 1 OF 1

Flex Duct Mounting Ring (FDMR)

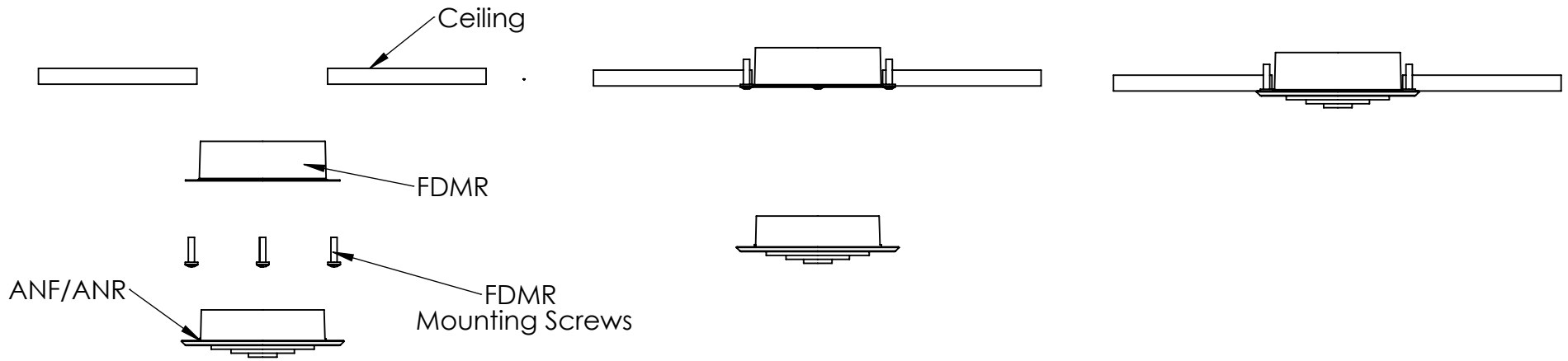

1. Insert the FDMR into the ceiling.
2. Fasten the FDMR into the ceiling using the mounting screws.
3. Insert the ANF/ANR into the FDMR. Rotate the ANF/ANR until it locks into the place. The "U" tabs should fit around the tightening screws.
4. Tighten using a Phillips screw driver.

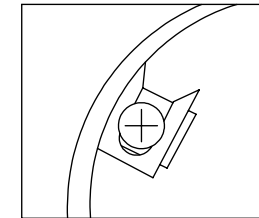
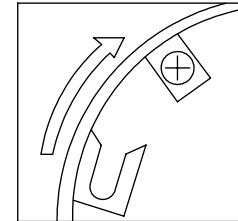

Optional on sizes 6"-24'

PROPRIETARY AND CONFIDENTIAL
 THE INFORMATION CONTAINED IN THIS DRAWING IS THE SOLE PROPERTY OF AIRCONCEPTS, INC. ANY REPRODUCTION IN PART OR AS A WHOLE WITHOUT THE WRITTEN PERMISSION OF AIRCONCEPTS, INC IS PROHIBITED.

		UNLESS OTHERWISE SPECIFIED:		NAME	DATE
		DIMENSIONS ARE IN INCHES TOLERANCES: ± 1/32"	DRAWN	M.H.	10/29/14
		FRACTIONAL	CHECKED		
		ANGULAR: MACH ± BEND ±	ENG APPR.		
		TWO PLACE DECIMAL ±	MFG APPR.		
		THREE PLACE DECIMAL ±	Q.A.		
		INTERPRET GEOMETRIC TOLERANCING PER:	COMMENTS:		
		MATERIAL			
		FINISH			
NEXT ASSY	USED ON				
APPLICATION		DO NOT SCALE DRAWING			



ANF/ANR Instalation Instruction

SIZE	DWG. NO.	REV
A		
SCALE: 1:10	WEIGHT:	SHEET 1 OF 1

Concealed Mounting Ring

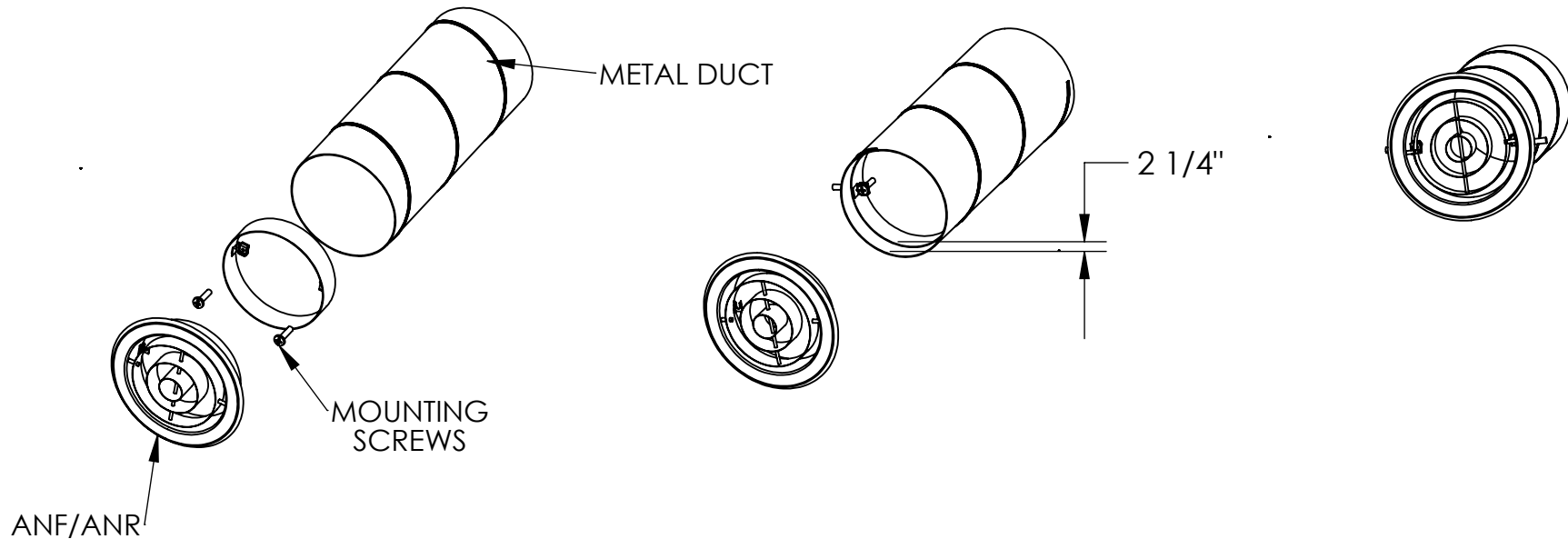

1. Insert the concealed mounting ring into the duct.
2. Fasten the concealed mounting ring into the duct using the mounting screws.
3. Insert the ANF/ANR into the concealed mounting ring. Rotate the ANF/ANR until it locks into the place. The "U" tabs should fit around the tightening screws.
4. Tighten using a Phillips screw driver.

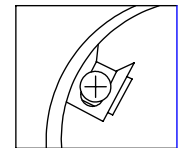
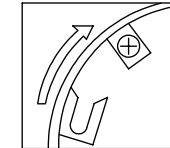

Note: Standard on sizes 6"-24" mount with provided concealed mounting ring.

PROPRIETARY AND CONFIDENTIAL
 THE INFORMATION CONTAINED IN THIS DRAWING IS THE SOLE PROPERTY OF AIRCONCEPTS, INC. ANY REPRODUCTION IN PART OR AS A WHOLE WITHOUT THE WRITTEN PERMISSION OF AIRCONCEPTS, INC IS PROHIBITED.

		UNLESS OTHERWISE SPECIFIED:		NAME	DATE
		DIMENSIONS ARE IN INCHES TOLERANCES: ± 1/32" FRACTIONAL ANGULAR: MACH ± BEND ± TWO PLACE DECIMAL ± THREE PLACE DECIMAL ±	DRAWN	M.H.	03-22-05
		INTERPRET GEOMETRIC TOLERANCING PER:	CHECKED		
		MATERIAL	ENG APPR.		
		FINISH	MFG APPR.		
NEXT ASSY	USED ON		Q.A.		
APPLICATION		DO NOT SCALE DRAWING	Note: Sizes 6"-16" Mount with Provided Concealed Mounting Ring		



ANF/ANR INSTALLATION

SIZE	DWG. NO.	REV
A		
SCALE: 1:12	WEIGHT:	SHEET 1 OF 1