



American  
***VENTUS***

2017





01

## VTS Group

1.1	VTS Group .....	05
1.2	3 Elements of Success .....	08



02

## Units

2.1	Horizontal AVS Product Range .....	12
2.2	Vertical AVS Product Range .....	13
2.3	American Ventus .....	14
2.4	Design .....	16
2.5	Air Tightness .....	18



03

## Technical Parameters

3.1	AVS 8-55 - Supply & Exhaust .....	22
3.2	AVS 65-380 - Supply & Exhaust .....	24
3.3	AVS 8-55 - Cross-Flow Plate .....	26
3.4	AVS 65-380 - Cross-Flow Plate .....	30
3.5	AVS 12 - 65 with Energy Wheel .....	36
3.6	AVS 85-380 with Energy Wheel .....	38
3.7	AVS - Vertical Configurations .....	42



04

## Connection and Controls

4.1	Connecting Point .....	46
4.2	Construction and Wiring .....	47
4.3	Controls .....	48
4.4	Main Elements .....	49
4.5	Control Applications List .....	52
4.6	Supply Ahus .....	53



05

## Functions

5.1	Functions .....	62
5.2	VTS Psychrometric Chart .....	65
5.3	Customer Testimonies .....	68
5.4	Symbols and Labels .....	69



**01**

VTS Group



**VTS GROUP** is a manufacturer of technically advanced equipment for the HVAC Sector using innovative technologies in the sphere of project research, production and logistics.

## OUR MISSION

**NO. 1** AHU  
MANUFACTURER  
IN THE WORLD

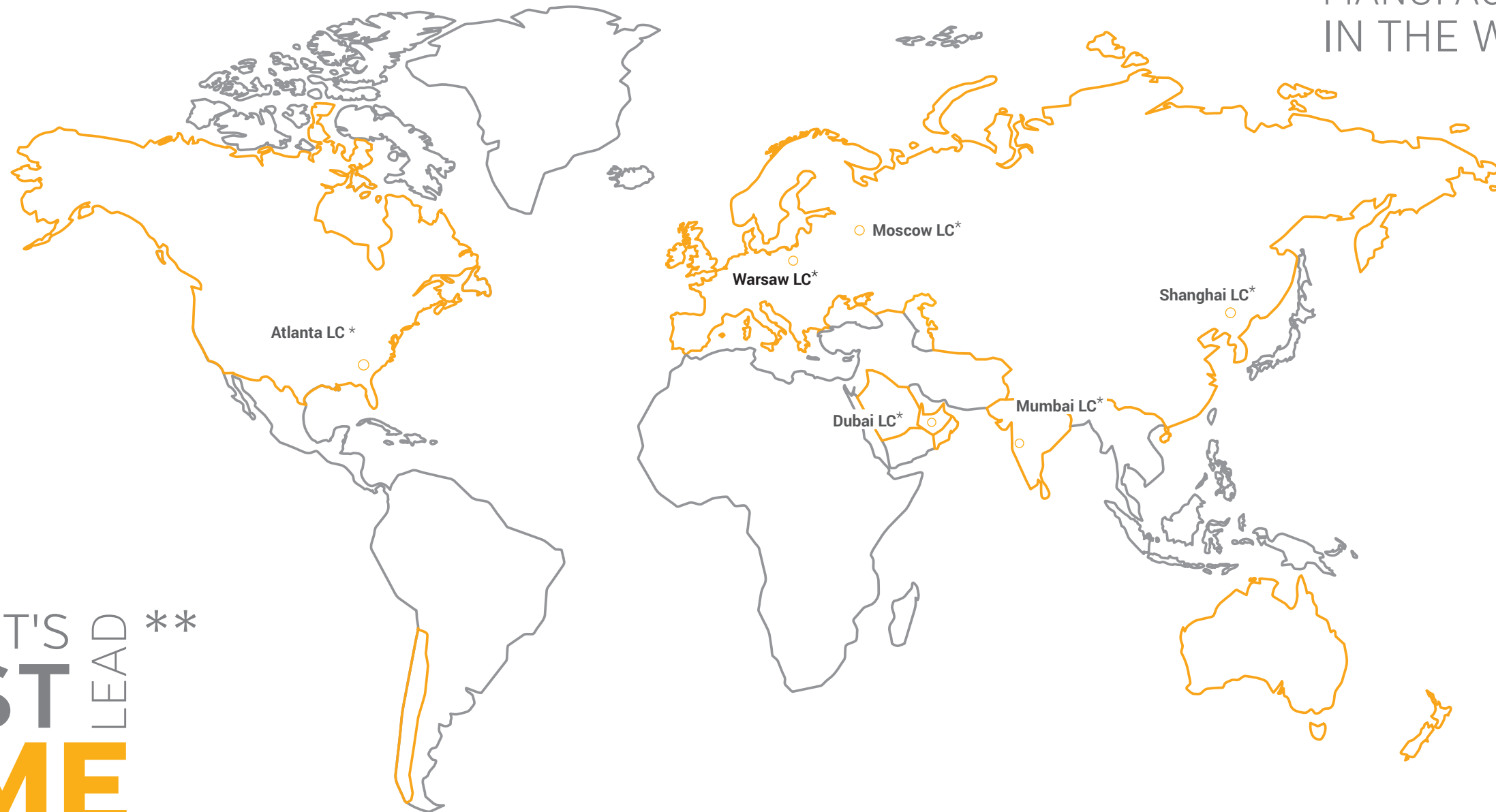

MARKET'S **BEST** LEAD **TIME** \*\*

\* Logistics center

\*\* Factory will confirm lead time based on the units selection.





# 3 ELEMENTS OF SUCCESS

Consistently Superior quality of products. Unbeatable prices in the market. The shortest lead time. These three elements of market policy ensure that VTS is always one step ahead, in every region of the World.

Following the proven assembly method of the automotive Industry, VTS created a network of 6 efficiently functioning logistics centers: **Atlanta, Dubai, Moscow, Shanghai, Warsaw and Mumbai**. Therefore guaranteeing the shortest delivery terms in the market, regardless of the region in the world.

Mass scale production of reproducible devices makes it possible for VTS to offer our product at the **most competitive price while retaining the best quality**.

Multilevel quality control systems enables VTS to offer the longest warranty in the market. **A 2-year warranty of trouble free equipment operation**.

MARKET'S **BEST** LEAD TIME

6 LOGISTICS CENTERS

\$ competitive price

85 000 UNITS SOLD ANNUALLY

Q the highest quality

2 optional warranty YEARS FOR EACH UNIT

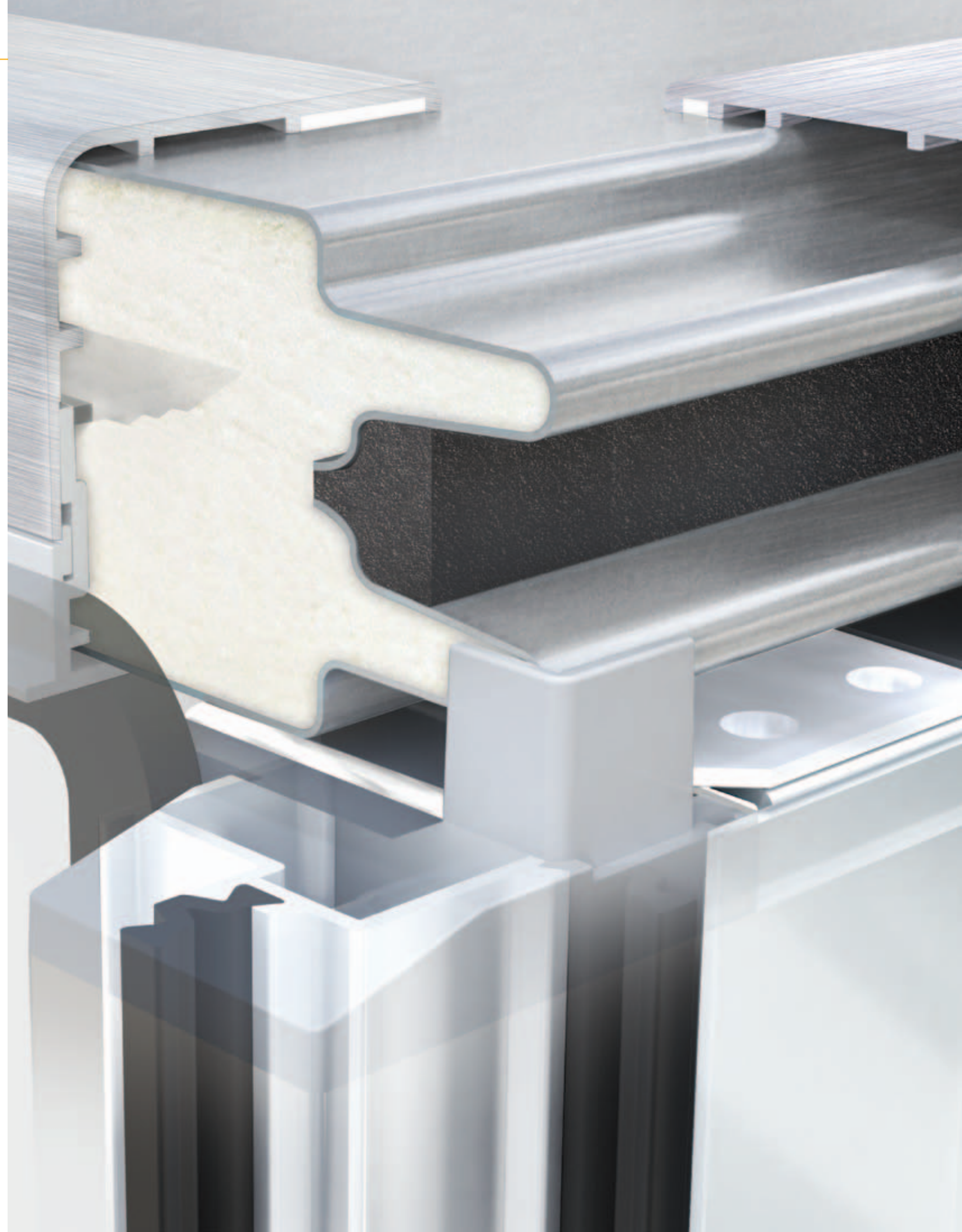



**02**

Units



# HORIZONTAL AVS PRODUCT RANGE

The American VENTUS Air Handling units have been designed to give the **flexibility of a Semi-Custom unit** with our modular configuration.

Our AVS line is available in **15 different sizes from 800 CFM to 38,000 CFM.**

As standard, all our AVS units have a **2,000 hour salt spray test resistance** on the external coating.

The units can be configured for different inlet and outlet locations for easy duct connection and right or left hand configuration.

VTS Air Handlers can be shipped as a fully assembled unit or delivered by sections for easier handling and space restrictions on the building.

In addition, VTS units are made with high durability 2 inch polyurethane sandwich panels which minimize vibration, noise and eliminates thermal bridges compared with typical blower coils and air handling units. This construction significantly reduces the emission of acoustic energy released through the casing; enabling the quiet operation of our AHUs.



# VERTICAL AVS PRODUCT RANGE

Our vertical American VENTUS line is available in six nominal airflow sizes **from 800 CFM up to 4,500 CFM,** while the cooling capacities are available from 0.5 to 30 tons.

They are floor mounted units that are mostly used in situations where a smaller AHU footprint is needed. Like their horizontal counterparts, they can be configured with different inlet and outlet locations to allow for more flexibility when ducting the units. The vertical AVS units can also be configured for right or left hand access for easier installation in the field.

The vertical AVS line now features the same innovative 2 inch sandwich panels as the horizontal AVS units; this allows the vertical units to have the same durability, structural integrity, and thermal insulation that have come to be expected from VTS. In addition to the casing upgrade, vertical units are now capable of handling more rows of coils than before leading to higher heating and cooling capacities. The end result of this is that the chosen VTS unit performs the same regardless of size or configuration.





RELIABLE  
AND TIGHT  
CONSTRUCTION



TOP QUALITY  
COMPONENTS



INTELLIGENT  
CONTROLS  
SYSTEMS



SAFETY  
OF USE





# DESIGN

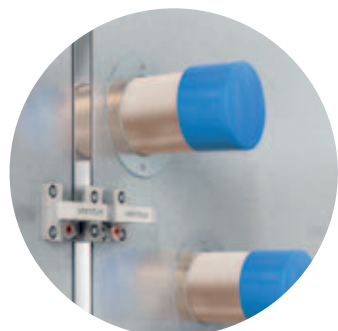

**MORE THAN 2,000 HOURS SALT SPRAY TEST PROTECTION**

## RESISTANCE TO CORROSION

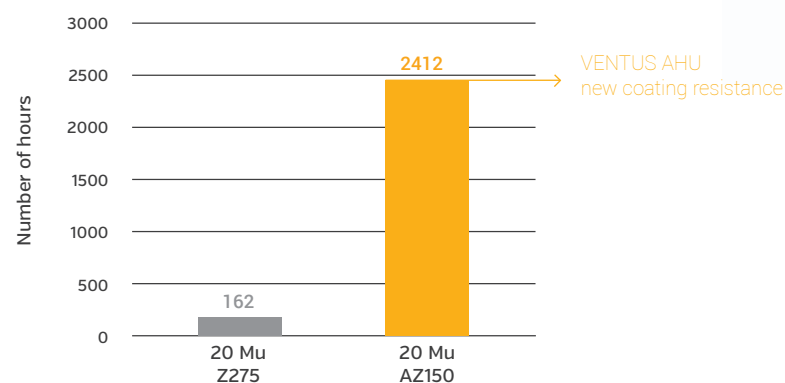

Salt spray test according to ASATMB - 117



**ALUMINUM POSTS**  
AS **STANDARD**  
FOR ALL TYPES OF UNITS

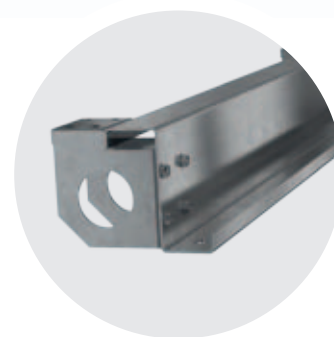
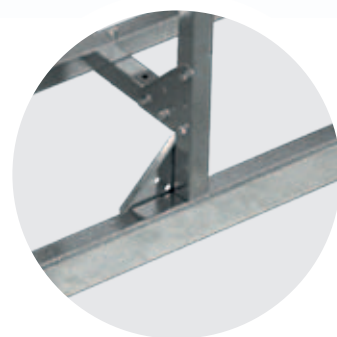

**Z PROFILE**  
AVS040-AVS085

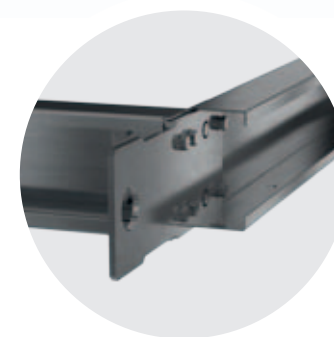

**C PROFILE**  
AVS100-AVS380



**CURB READY RAILS**  
AVS040-AVS380

**GALVANIZED STEEL SUPPORT**  
AS **STANDARD**  
FOR ALL TYPES OF UNITS

## CASING SKIN

- » high rigidity and durability of the AHU structure
- » low absorption of heat radiation and UV
- » perfect resistance to weather conditions

## FAN SECTION CAGE

- » high longitudinal stiffness of the structure
- » easy section assembly

## CONVENIENT

- » easy transport
- » great profile resistance to deflection

## STRUCTURAL POSTS

- » thermally broken as standard
- » high resistance to weather conditions and UV radiation



# AIR TIGHTNESS

**SMART HINGE SYSTEM\***

**VTS PATENTED SOLUTION**



INSPECTION PANELS EQUIPPED WITH THE OPEN / CLOSE SMART SYSTEM AND NEW PROTECTIVE CORNERS

- » easy to use, enabling quick opening and closing of the inspection panel
- » smart hinge - prevents seal damage when the panel is opened (VTS proprietary and patented solution)
- » perfect ergonomics with an integrated handle and hinge function
- » low risk of damage to panel

\* patent pending; information will be published after it's formal validation.

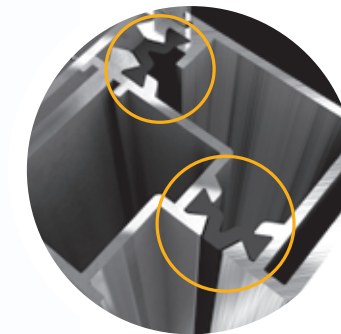
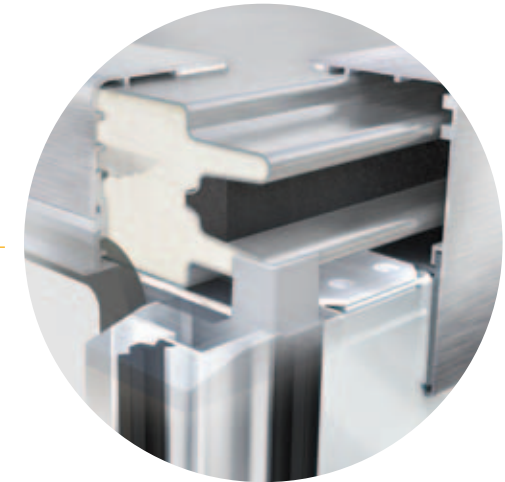

**THERMAL BREAK**

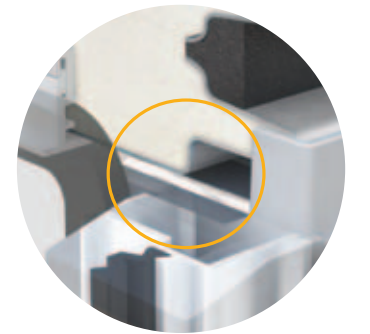

**ADDITIONAL POST SEALING**

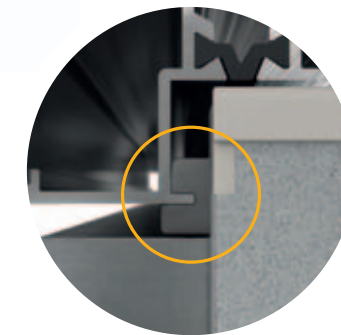

**LABYRINTH SEALING**



**ADDITIONAL SEALING EDGE**

ALUMINUM STRUCTURAL POSTS WITH AN ADDITIONAL SEALING FIN AND A THERMAL INSERT

- » thermal break as standard - ensures no condensation outside the AHU
- » the fin ensures labyrinth sealing – currently the most effective solution on the market, mainly used in laboratory equipment
- » original solution consisting in the use of symmetrical channel tension filled with a sealing compound, which provides 100% tightness of the connection between the column and construction structure



**03**

Technical  
Parameters



# AVS 8-55 - SUPPLY & EXHAUST

Rated parameters		Recommended range of airflow																											
Size		AVS 008		AVS 012		AVS 016		AVS 020		AVS 030		AVS 040		AVS 055															
15 000	[CFM]	[Bar chart showing airflow ranges for each model]																											
10 000		[Bar chart showing airflow ranges for each model]																											
5 000		[Bar chart showing airflow ranges for each model]																											
0		[Bar chart showing airflow ranges for each model]																											
Min.		332	427	427	427	480	618	618	618	636	819	819	819	806	1037	1037	1037	1185	1524	1524	1524	1567	1945	1945	1945	2003	2419	2419	2419
Max.		2140	1883	1254	924	3091	2719	1817	1339	4096	3605	2486	1832	5186	4564	3331	2454	7622	6708	4835	3563	10078	8559	6697	4934	12880	10648	8758	6453
H <sub>f</sub>		3.54																											
H		21.97	21.97	21.97	21.97	24.02	24.02	24.02	24.02	27.17	27.17	27.17	27.17	32.48	32.48	32.48	32.48	37.20	37.20	37.20	37.20	41.14	41.14	41.14	41.14	41.14	41.14	41.14	41.14
W		27.95	27.95	27.95	27.95	38.62	38.62	38.62	38.62	44.21	44.21	44.21	44.21	46.77	46.77	46.77	46.77	53.50	53.50	53.50	53.50	59.06	59.06	59.06	59.06	66.14	66.14	66.14	66.14
W <sub>i</sub>		24.02	24.02	24.02	24.02	34.68	34.68	34.68	34.68	40.28	40.28	40.28	40.28	42.83	42.83	42.83	42.83	49.57	49.57	49.57	49.57	55.12	55.12	55.12	55.12	62.20	62.20	62.20	62.20
H <sub>i</sub>		14.49	14.49	14.49	14.49	14.49	14.49	14.49	14.49	16.54	16.54	16.54	16.54	19.69	19.69	19.69	19.69	25.00	25.00	25.00	25.00	29.72	29.72	29.72	29.72	33.66	33.66	33.66	33.66

Main configuration	DE*	Basic configurations						
AVS-XXX-R-V	-	44.26	44.26	44.26	44.26	58.65	58.65	73.05
AVS-XXX-R-FV	-	58.65	58.65	58.65	58.65	73.05	73.05	87.45
AVS-XXX-R-H	-	73.05	73.05	73.05	73.05	87.45	87.45	101.85
AVS-XXX-R-C	-	73.05	73.05	73.05	73.05	87.45	87.45	101.85
AVS-XXX-R-C	✓	87.45	87.45	87.45	87.45	87.45	87.45	101.85
AVS-XXX-R-HC	-	87.45	87.45	87.45	87.45	101.85	101.85	116.24
AVS-XXX-R-HC	✓	101.85	101.85	101.85	101.85	101.85	101.85	116.24
AVS-XXX-R-CH	-	87.45	87.45	87.45	87.45	101.85	101.85	116.24
AVS-XXX-R-CH	✓	101.85	101.85	101.85	101.85	101.85	101.85	116.24
AVS-XXX-R-HCH	-	101.85	101.85	101.85	101.85	116.24	116.24	130.64
AVS-XXX-R-HCH	✓	116.24	116.24	116.24	116.24	116.24	116.24	130.64
AVS-XXX-R-GH	-	87.45	87.45	87.45	87.45	101.85	101.85	116.24
AVS-XXX-R-G	-	73.05	73.05	73.05	73.05	87.45	87.45	101.85
AVS-XXX-R-G	-	101.85	101.85	101.85	101.85	116.24	116.24	130.64
AVS-XXX-R-GCH	✓	116.24	116.24	116.24	116.24	116.24	116.24	130.64

Units with external filters instead of internal are shorter by 14.4 inches

		Additional functions					
Empty section	L <sub>min</sub>	29.86	29.86	29.86	29.86	29.86	29.86
	L <sub>max</sub>	29.86	29.86	29.86	29.86	29.86	29.86
Mixing box	L	29.86	29.86	29.86	29.86	29.86	29.86

\* Include Droplet Eliminator after Cooling Coil



# DIMENSIONS - AVS 8-55 - SUPPLY & EXHAUST

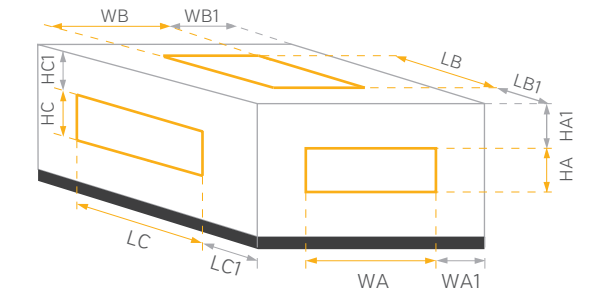
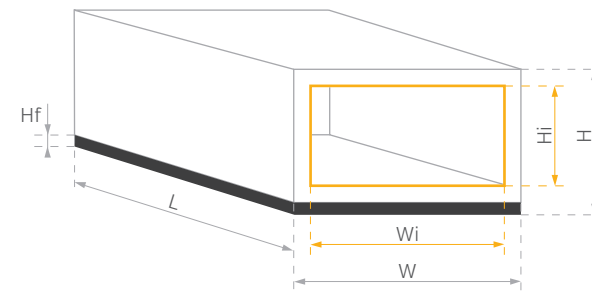

## AIR INLET / DISCHARGE DIMENSIONS

END FULL (FF)				
UNIT	WA	HA	WA1	HA1
AVS 008	21.65	12.13	3.15	3.15
AVS 012	32.32	12.13	3.15	3.15
AVS 016	37.91	14.17	3.15	3.15
AVS 020	40.47	17.32	3.15	3.15
AVS 030	47.20	22.64	3.15	3.15
AVS 040	52.76	27.36	3.15	3.15
AVS 055	59.84	31.30	3.15	3.15

END (FS)				
UNIT	WA	HA	WA1	HA1
AVS 008	17.99	7.99	5.03	5.23
AVS 012	25.98	7.99	6.33	5.23
AVS 016	34.02	7.99	5.13	6.23
AVS 020	25.98	12.01	10.43	5.83
AVS 030	34.02	12.01	9.83	8.53
AVS 040	40.47	17.32	9.29	8.19
AVS 055	47.20	22.64	9.47	7.48

Top (US)				
UNIT	WB	LB	WB1	LB1
AVS 008	17.99	7.99	5.03	4.33
AVS 012	25.98	7.99	6.33	4.33
AVS 016	34.02	7.99	5.13	4.33
AVS 020	25.98	12.01	10.43	4.33
AVS 030	34.02	12.01	9.83	4.33
AVS 040	40.47	17.32	9.29	8.27
AVS 055	47.20	22.64	9.47	5.31

Top (US)				
UNIT	WB	LB	WB1	LB1
AVS 008	17.94	7.94	5.00	11.46
AVS 012	25.94	7.94	6.34	11.46
AVS 016	33.94	7.94	5.16	11.46
AVS 020	25.94	11.94	10.43	9.46
AVS 030	33.94	11.94	9.80	9.46
AVS 040	47.20	22.64	5.93	8.66
AVS 055	52.76	27.36	6.69	8.66

## UNIT CODING

AVS - XXX - R/L - EM / HC / EM

- AVS - type of AHU family
- XXX - size of unit (equal to the rated air flow in cfm)
- R/L - inspection side (R- right, L-left)
- EM - symbols of additional functions upstream main functions
- HC - symbols of main thermodynamic functions (basic functions)
- EM - symbols of additional functions downstream main functions
- Length depends on AHU equipment

Side (BS)				
UNIT	HC	LC	HC1	LC1
AVS 008	10.94	7.94	4.33	3.74
AVS 012	10.94	7.94	4.33	3.74
AVS 016	12.94	7.94	4.33	3.74
AVS 020	15.94	11.94	4.33	3.82
AVS 030	20.94	11.94	4.33	3.98
AVS 040	16.26	14.96	6.89	8.70
AVS 055	24.13	14.96	6.89	6.73



# AVS 65-380 - SUPPLY & EXHAUST

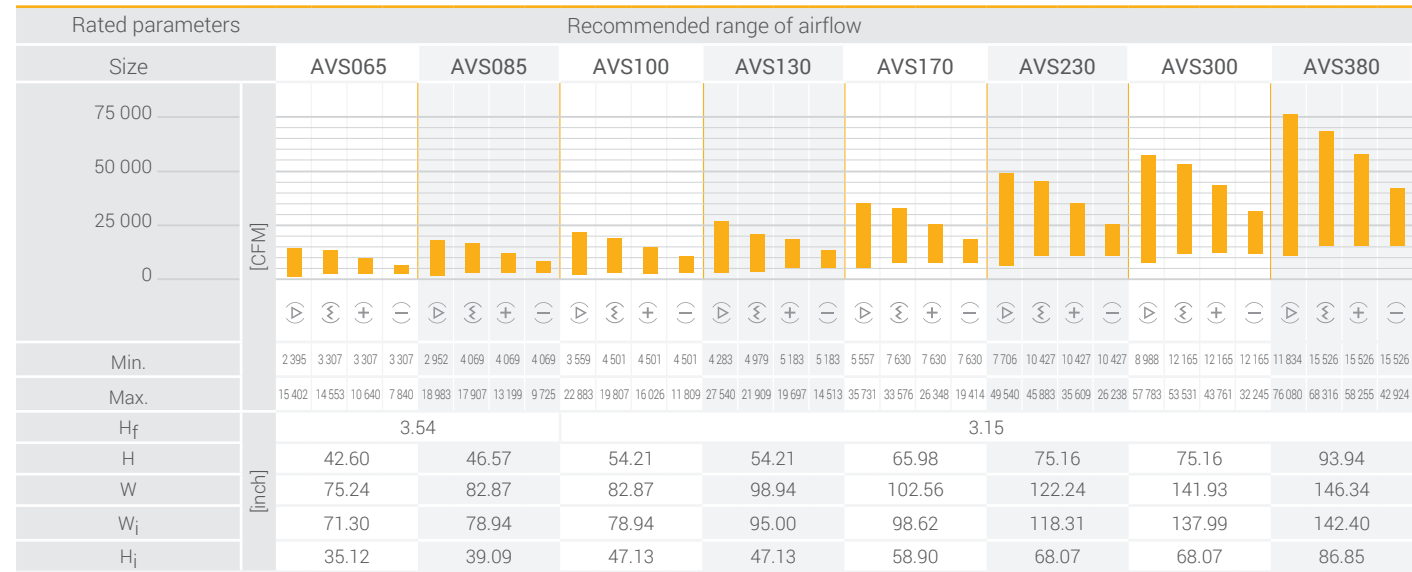

Main configuration	DE*	Basic configurations							
AVS-XXX-R-V	-	73.05	73.05	58.65	58.65	73.05	73.05	73.05	73.05
AVS-XXX-R-FV	-	87.45	87.45	73.05	73.05	87.45	87.45	87.45	87.45
AVS-XXX-R-H	-	101.85	101.85	87.45	87.45	101.85	101.85	101.85	101.85
AVS-XXX-R-C	-	101.85	101.85	87.45	87.45	101.85	101.85	101.85	101.85
AVS-XXX-R-C	✓	101.85	101.85	87.45	87.45	101.85	101.85	101.85	101.85
AVS-XXX-R-HC	-	116.24	116.24	101.85	101.85	116.24	116.24	116.24	116.24
AVS-XXX-R-HC	✓	116.24	116.24	101.85	101.85	116.24	116.24	116.24	116.24
AVS-XXX-R-CH	-	116.24	116.24	101.85	101.85	116.24	116.24	116.24	116.24
AVS-XXX-R-CH	✓	116.24	116.24	101.85	101.85	116.24	116.24	116.24	116.24
AVS-XXX-R-HCH	-	130.64	130.64	116.24	116.24	130.64	130.64	130.64	130.64
AVS-XXX-R-HCH	✓	130.64	130.64	116.24	116.24	130.64	130.64	130.64	130.64
AVS-XXX-R-GH	-	116.24	116.24	101.85	101.85	116.24	116.24	116.24	116.24
AVS-XXX-R-G	-	101.85	101.85	87.45	87.45	101.85	101.85	101.85	101.85
AVS-XXX-R-G	-	130.64	130.64	116.24	116.24	130.64	130.64	130.64	130.64
AVS-XXX-R-GCH	✓	130.64	130.64	116.24	116.24	130.64	130.64	130.64	130.64

Units with external filters instead of internal are shorter by 14.4 inches

		Additional functions							
Empty section	L <sub>min</sub>	29.86	29.86	29.86	29.86	29.86	29.86	29.86	29.86
	L <sub>max</sub>	29.86	44.26	44.26	44.26	44.26	44.26	44.26	44.26
Mixing box	L	29.86	44.26	44.26	44.26	44.26	44.26	44.26	44.26

\* Include Droplet Eliminator after Cooling Coil



# DIMENSIONS - AVS 65-380 - SUPPLY & EXHAUST

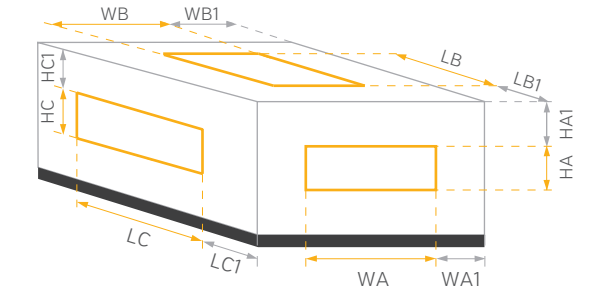
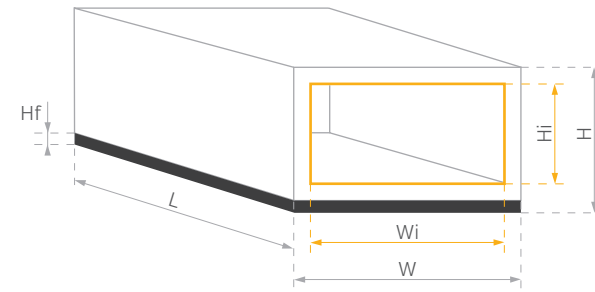

## AIR INLET / DISCHARGE DIMENSIONS

END FULL (FF)	UNIT	WA	HA	WA1	HA1
AVS 065	68.94	32.76	3.15	3.15	
AVS 085	76.57	36.73	3.15	3.15	
AVS 100	76.57	44.76	3.15	3.15	
AVS 130	92.64	44.76	3.15	3.15	
AVS 170	96.26	56.54	3.15	3.15	
AVS 230	115.94	65.71	3.15	3.15	
AVS 300	135.63	65.71	3.15	3.15	
AVS 380	140.04	84.49	3.15	3.15	

END (FS)	UNIT	WA	HA	WA1	HA1
AVS 065	47.20	22.64	14.02	8.23	
AVS 085	59.84	31.30	11.52	5.87	
AVS 100	59.84	31.30	11.52	9.88	
AVS 130	76.57	36.73	11.18	7.17	
AVS 170	76.57	36.73	12.99	13.07	
AVS 230	104.33	36.73	8.96	17.64	
AVS 300	124.02	36.73	8.96	17.64	
AVS 380	127.95	36.73	9.19	27.05	

Top (US)	UNIT	WB	LB	WB1	LB1
AVS 065	47.20	22.64	14.02	5.31	
AVS 085	59.84	31.30	11.52	8.27	
AVS 100	59.84	31.30	11.52	8.27	
AVS 130	76.57	36.73	11.18	5.31	
AVS 170	76.57	36.73	12.99	5.31	
AVS 230	104.33	36.73	8.96	5.31	
AVS 300	124.02	36.73	8.96	5.31	
AVS 380	127.95	36.73	9.19	5.31	

Top (US)	UNIT	WB	LB	WB1	LB1
AVS 065	59.84	31.30	7.70	5.31	
AVS 085	59.84	31.30	11.52	5.31	
AVS 100	59.84	31.30	11.52	5.31	
AVS 130	75.31	29.13	11.81	5.31	
AVS 170	76.57	36.73	12.99	5.31	
AVS 230	104.33	36.73	8.96	5.31	
AVS 300	124.02	36.73	8.96	8.66	
AVS 380	127.95	36.73	9.19	8.66	

## UNIT CODING

### AVS - XXX - R/L - EM / HC / EM

AVS - type of AHU family  
 XXX - size of unit (equal to the rated air flow in cfm)  
 R/L - inspection side (R- right, L-left)  
 EM - symbols of additional functions upstream main functions  
 HC - symbols of main thermodynamic functions (basic functions)  
 EM - symbols of additional functions downstream main functions  
 Length depends on AHU equipment

Side (BS)	UNIT	HC	LC	HC1	LC1
AVS 065	24.13	14.96	6.89	7.46	
AVS 085	28.07	29.13	6.89	7.48	
AVS 100	35.94	29.13	6.89	7.56	
AVS 130	35.94	29.13	6.89	7.56	
AVS 170	47.76	29.13	6.89	7.54	
AVS 230	59.57	29.13	6.89	6.22	
AVS 300	59.57	29.13	6.89	6.22	
AVS 380	75.31	29.13	6.89	7.74	



# AVS 8-55 - CROSS-FLOW PLATE

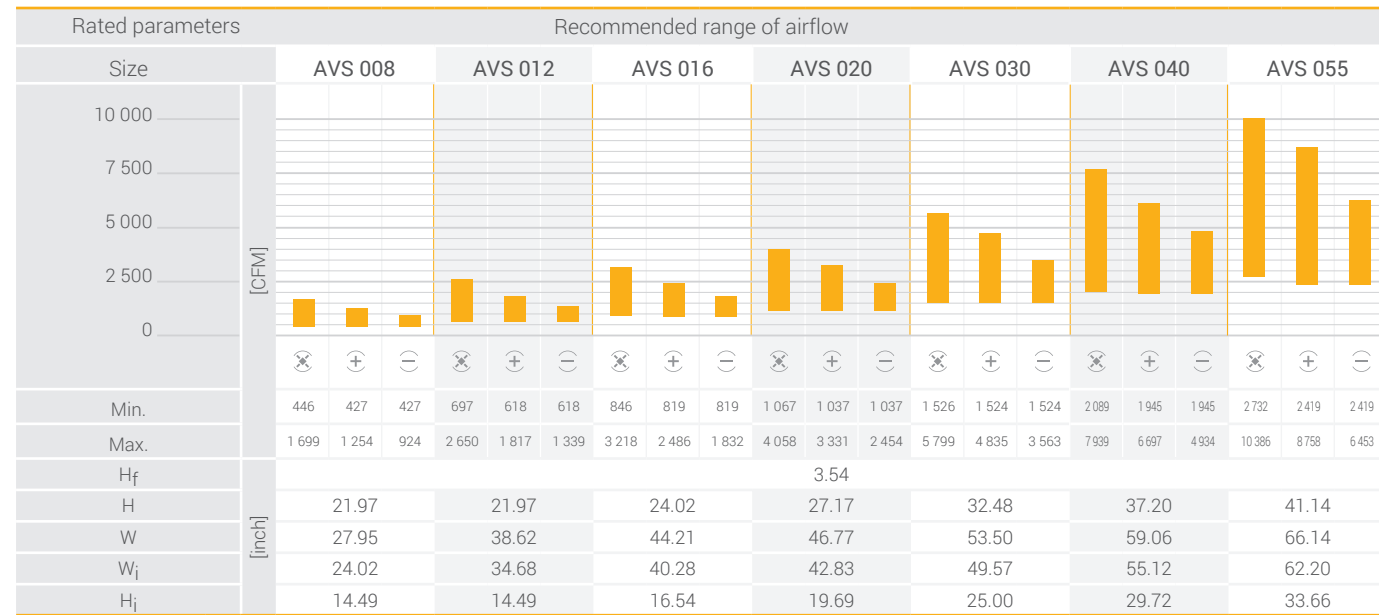

Main configuration DE*		Basic configurations																				
Size	AVS 008	AVS 012	AVS 016	AVS 020	AVS 030	AVS 040	AVS 055															
Min.	446	427	427	697	618	618	846	819	819	1067	1037	1037	1526	1524	1524	2089	1945	1945	2732	2419	2419	
Max.	1699	1254	924	2650	1817	1339	3218	2486	1832	4058	3331	2454	5799	4835	3563	7939	6697	4934	10386	8758	6453	
H <sub>f</sub>	3.54																					
H	21.97	21.97	21.97	24.02	27.17	27.17	32.48	32.48	32.48	37.20	37.20	37.20	41.14	41.14	41.14	41.14	41.14	41.14	41.14	41.14	41.14	41.14
W	27.95	38.62	38.62	44.21	46.77	46.77	53.50	53.50	53.50	59.06	59.06	59.06	66.14	66.14	66.14	66.14	66.14	66.14	66.14	66.14	66.14	66.14
W <sub>i</sub>	24.02	34.68	34.68	40.28	42.83	42.83	49.57	49.57	49.57	55.12	55.12	55.12	62.20	62.20	62.20	62.20	62.20	62.20	62.20	62.20	62.20	62.20
H <sub>i</sub>	14.49	14.49	14.49	16.54	19.69	19.69	25.00	25.00	25.00	29.72	29.72	29.72	33.66	33.66	33.66	33.66	33.66	33.66	33.66	33.66	33.66	33.66

\* Include Droplet Eliminator after Cooling Coil

Main configuration DE*		Basic configurations						
Size	AVS 008	AVS 012	AVS 016	AVS 020	AVS 030	AVS 040	AVS 055	
L2	116.24	116.24	116.24	116.24	145.04	145.04	173.83	
L1	101.85	101.85	101.85	101.85	130.64	130.64	159.44	
K	14.40	14.40	14.40	14.40	14.40	14.40	14.40	
LT	116.24	116.24	116.24	116.24	145.04	145.04	173.83	
L2	101.85	101.85	101.85	101.85	130.64	130.64	159.44	
L1	116.24	116.24	116.24	116.24	145.04	145.04	173.83	
K	0.00	0.00	0.00	0.00	0.00	0.00	0.00	
LT	116.24	116.24	116.24	116.24	145.04	145.04	173.83	
L2	101.85	101.85	101.85	101.85	130.64	130.64	159.44	
L1	116.24	116.24	116.24	116.24	145.04	145.04	173.83	
K	0.00	0.00	0.00	0.00	0.00	0.00	0.00	
LT	116.24	116.24	116.24	116.24	145.04	145.04	173.83	
L2	101.85	101.85	101.85	101.85	130.64	130.64	159.44	
L1	116.24	116.24	116.24	116.24	145.04	145.04	173.83	
K	0.00	0.00	0.00	0.00	0.00	0.00	0.00	
LT	116.24	116.24	116.24	116.24	145.04	145.04	173.83	
L2	101.85	101.85	101.85	101.85	130.64	130.64	159.44	
L1	116.24	116.24	116.24	116.24	145.04	145.04	173.83	
K	0.00	0.00	0.00	0.00	0.00	0.00	0.00	
LT	116.24	116.24	116.24	116.24	145.04	145.04	173.83	
L2	101.85	101.85	101.85	101.85	130.64	130.64	159.44	
L1	116.24	116.24	116.24	116.24	145.04	145.04	173.83	
K	0.00	0.00	0.00	0.00	0.00	0.00	0.00	
LT	116.24	116.24	116.24	116.24	145.04	145.04	173.83	
L2	101.85	101.85	101.85	101.85	130.64	130.64	159.44	
L1	116.24	116.24	116.24	116.24	145.04	145.04	173.83	
K	0.00	0.00	0.00	0.00	0.00	0.00	0.00	
LT	116.24	116.24	116.24	116.24	145.04	145.04	173.83	
L2	101.85	101.85	101.85	101.85	130.64	130.64	159.44	
L1	116.24	116.24	116.24	116.24	145.04	145.04	173.83	
K	0.00	0.00	0.00	0.00	0.00	0.00	0.00	
LT	116.24	116.24	116.24	116.24	145.04	145.04	173.83	
L2	101.85	101.85	101.85	101.85	130.64	130.64	159.44	
L1	116.24	116.24	116.24	116.24	145.04	145.04	173.83	
K	0.00	0.00	0.00	0.00	0.00	0.00	0.00	
LT	116.24	116.24	116.24	116.24	145.04	145.04	173.83	
L2	101.85	101.85	101.85	101.85	130.64	130.64	159.44	
L1	116.24	116.24	116.24	116.24	145.04	145.04	173.83	
K	0.00	0.00	0.00	0.00	0.00	0.00	0.00	
LT	116.24	116.24	116.24	116.24	145.04	145.04	173.83	
L2	101.85	101.85	101.85	101.85	130.64	130.64	159.44	
L1	116.24	116.24	116.24	116.24	145.04	145.04	173.83	
K	0.00	0.00	0.00	0.00	0.00	0.00	0.00	
LT	116.24	116.24	116.24	116.24	145.04	145.04	173.83	
L2	101.85	101.85	101.85	101.85	130.64	130.64	159.44	
L1	116.24	116.24	116.24	116.24	145.04	145.04	173.83	
K	0.00	0.00	0.00	0.00	0.00	0.00	0.00	
LT	116.24	116.24	116.24	116.24	145.04	145.04	173.83	

\* Include Droplet Eliminator after Cooling Coil











# DIMENSIONS - AVS 8-55 - CROSS-FLOW PLATE

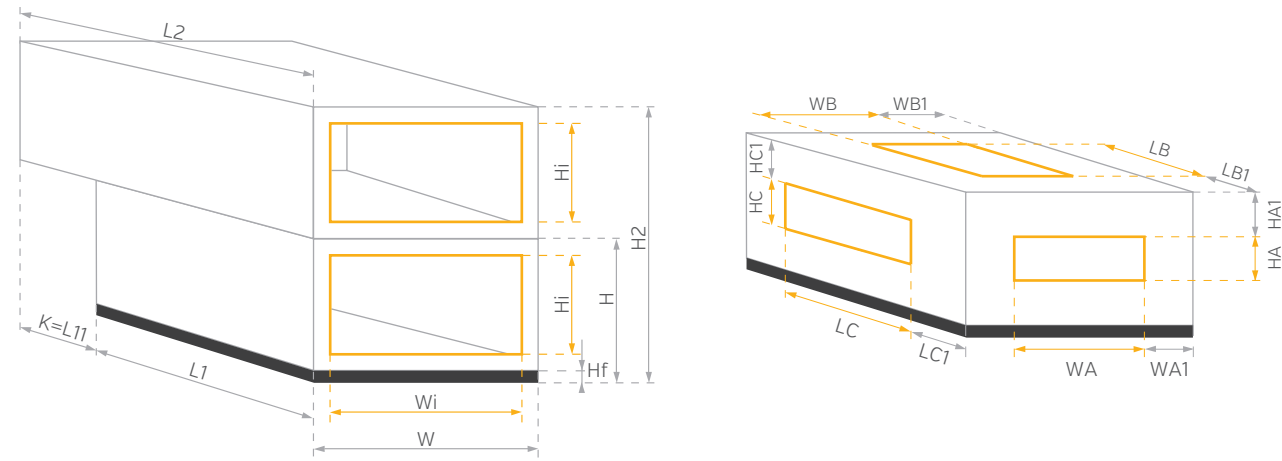

## AIR INLET / DISCHARGE DIMENSIONS

END FULL (FF)	UNIT	WA	HA	WA1	HA1
AVS 008		21.65	12.13	3.15	3.15
AVS 012		32.32	12.13	3.15	3.15
AVS 016		37.91	14.17	3.15	3.15
AVS 020		40.47	17.32	3.15	3.15
AVS 030		47.20	22.64	3.15	3.15
AVS 040		52.76	27.36	3.15	3.15
AVS 055		59.84	31.30	3.15	3.15

END (FS)	UNIT	WA	HA	WA1	HA1
AVS 008		17.97	7.97	5.00	5.24
AVS 012		25.97	7.97	6.34	5.24
AVS 016		33.97	7.97	5.16	6.26
AVS 020		25.97	11.97	10.43	5.83
AVS 030		33.97	11.97	9.80	8.50
AVS 040		40.51	17.36	9.29	8.19
AVS 055		47.24	22.68	9.47	7.48

Side (BS)	UNIT	HC	LC	HC1	LC1
AVS 008		10.94	7.94	4.33	3.74
AVS 012		10.94	7.94	4.33	3.74
AVS 016		12.94	7.94	4.33	3.74
AVS 020		15.94	11.94	4.33	3.82
AVS 030		20.94	11.94	4.33	3.98
AVS 040		16.26	14.96	6.89	8.70
AVS 055		24.13	14.96	6.89	6.73

## UNIT CODING

AVS - XX

AVS - type of AHU family  
 XXX - size of unit (equal to the rated air flow in cfm\*0.001)  
 R/L - inspection side (R- right, L -left)  
 PHC - symbols of main thermodynamic functions (basic functions)  
 Length depends on AHU equipment



# DIMENSIONS - AVS 65-380 - CROSS-FLOW PLATE

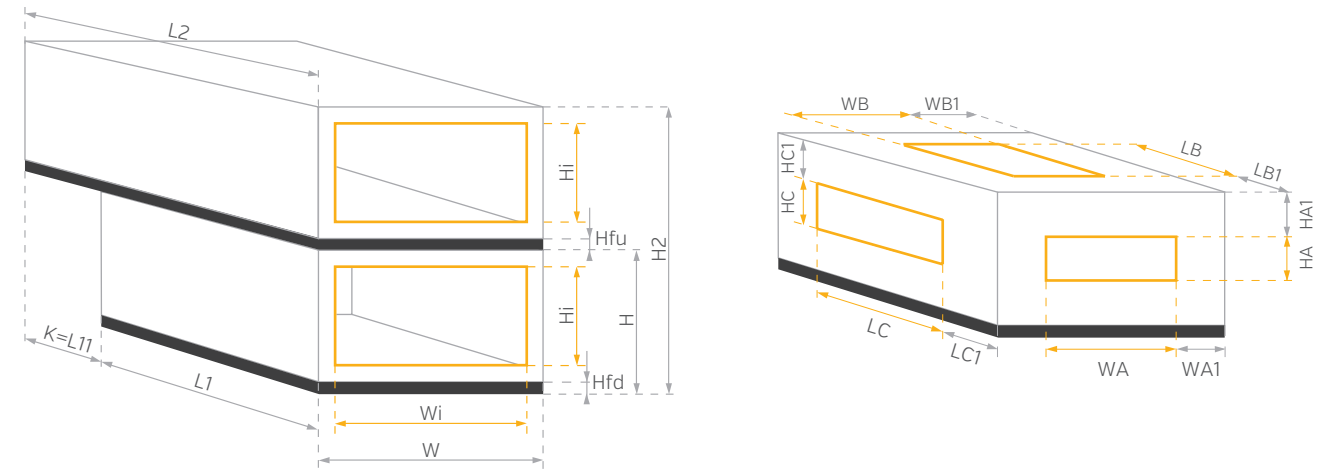

## AIR INLET / DISCHARGE DIMENSIONS

END FULL (FF)	UNIT	WA	HA	WA1	HA1
AVS 065		68.94	32.76	3.15	3.15
AVS 085		76.57	36.73	3.15	3.15
AVS 100		76.57	44.76	3.15	3.15
AVS 130		92.64	44.76	3.15	3.15
AVS 170		96.26	56.54	3.15	3.15
AVS 230		115.94	65.71	3.15	3.15
AVS 300		135.63	65.71	3.15	3.15
AVS 300		140.04	84.49	3.15	3.15

END (FS)	UNIT	WA	HA	WA1	HA1
AVS 065		47.24	22.68	14.02	8.23
AVS 085		59.88	31.34	11.52	5.87
AVS 100		59.88	31.34	11.52	9.88
AVS 130		76.61	36.77	11.18	7.17
AVS 170		76.61	36.77	12.99	13.07
AVS 230		104.37	36.77	8.96	17.64
AVS 300		124.06	36.77	8.96	17.64
AVS 380		127.99	36.77	9.19	27.05

Side (BS)	UNIT	HC	LC	HC1	LC1
AVS 065		24.13	14.96	6.89	7.46
AVS 085		28.07	29.13	6.89	7.48
AVS 100		35.94	29.13	6.89	7.56
AVS 130		35.94	29.13	6.89	7.56
AVS 170		47.76	29.13	6.89	7.54
AVS 230		59.57	29.13	6.89	6.22
AVS 300		59.57	29.13	6.89	6.22
AVS 380		75.31	29.13	6.89	7.74

## UNIT CODING

AVS - XX

AVS - type of AHU family  
 XXX - size of unit (equal to the rated air flow in cfm\*0.001)  
 R/L - inspection side (R- right, L -left)  
 PHC - symbols of main thermodynamic functions (basic functions)  
 Length depends on AHU equipment



# AVS 12 - 65 WITH ENERGY WHEEL

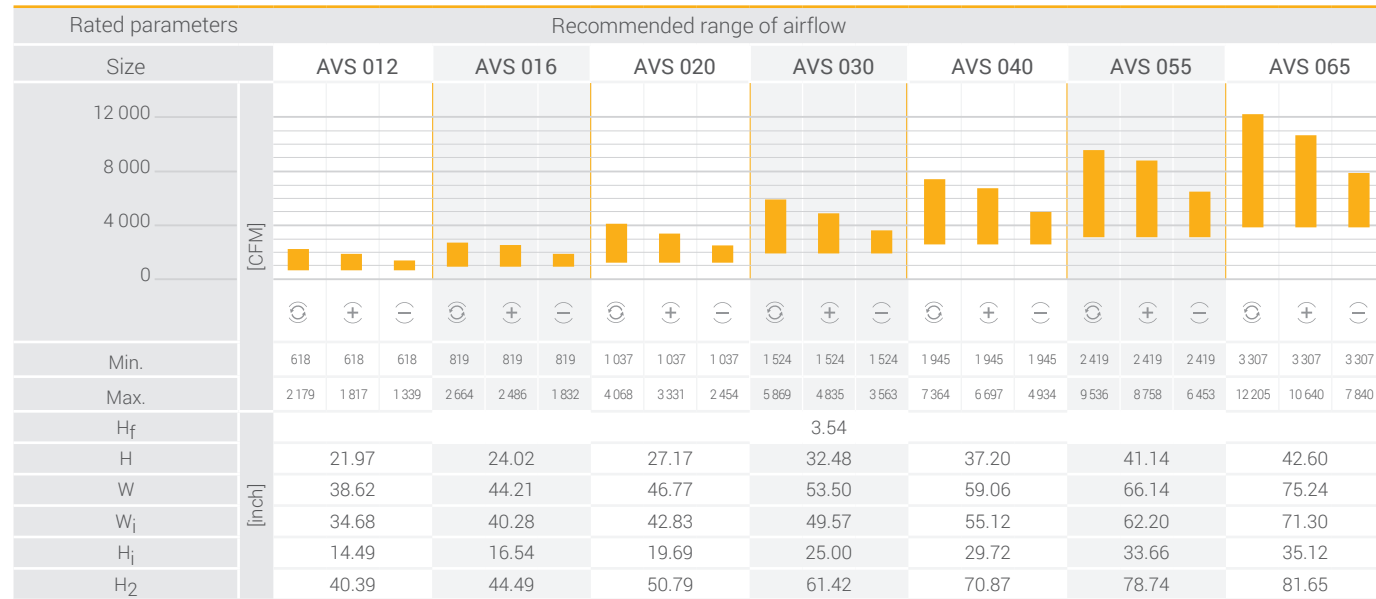

Main configuration DE*		Basic configurations						
	L2	87.45	87.45	87.45	101.85	101.85	116.24	116.24
	L1	87.45	87.45	87.45	101.85	101.85	116.24	116.24
	L11	28.80	28.80	28.80	43.19	43.19	57.59	57.59
	LT	87.45	87.45	87.45	101.85	101.85	116.24	116.24
	L2	87.45	87.45	87.45	101.85	101.85	116.24	116.24
	L1	87.45	87.45	87.45	101.85	101.85	116.24	116.24
	L11	28.80	28.80	28.80	43.19	43.19	57.59	57.59
	LT	87.45	87.45	87.45	101.85	101.85	116.24	116.24
	L2	87.45	87.45	87.45	101.85	101.85	116.24	116.24
	L1	101.85	101.85	101.85	116.24	116.24	130.64	130.64
	L11	28.80	28.80	28.80	43.19	43.19	57.59	57.59
	LT	101.85	101.85	101.85	116.24	116.24	130.64	130.64
	L2	101.85	101.85	101.85	116.24	116.24	130.64	130.64
	L1	87.45	87.45	87.45	101.85	101.85	116.24	116.24
	L11	43.19	43.19	43.19	57.59	57.59	71.99	71.99
	LT	101.85	101.85	101.85	116.24	116.24	130.64	130.64
	L2	116.24	116.24	116.24	130.64	130.64	145.04	145.04
	L1	130.64	130.64	130.64	145.04	145.04	159.44	159.44
	K	0.00	0.00	0.00	0.00	0.00	0.00	0.00
	LT	130.64	130.64	130.64	145.04	145.04	159.44	159.44
	L2	130.64	130.64	130.64	145.04	145.04	159.44	159.44
	L1	116.24	116.24	116.24	130.64	130.64	145.04	145.04
	K	14.40	14.40	14.40	14.40	14.40	14.40	14.40
	LT	130.64	130.64	130.64	145.04	145.04	159.44	159.44
	L2	87.45	87.45	87.45	101.85	101.85	116.24	116.24
	L1	116.24	116.24	116.24	116.24	116.24	130.64	130.64
	L11	28.80	28.80	28.80	43.19	43.19	57.59	57.59
	LT	116.24	116.24	116.24	116.24	116.24	130.64	130.64
	L2	101.85	101.85	101.85	116.24	116.24	130.64	130.64
	L1	87.45	87.45	87.45	101.85	101.85	116.24	116.24
	L11	43.19	43.19	43.19	57.59	57.59	71.99	71.99
	LT	101.85	101.85	101.85	116.24	116.24	130.64	130.64
	L2	101.85	101.85	101.85	116.24	116.24	130.64	130.64
	L1	87.45	87.45	87.45	101.85	101.85	116.24	116.24
	L11	43.19	43.19	43.19	57.59	57.59	71.99	71.99
	LT	101.85	101.85	101.85	116.24	116.24	130.64	130.64

\* Include Droplet Eliminator after Cooling Coil

Main configuration DE*		Basic configurations						
	L2	116.24	116.24	116.24	130.64	130.64	145.04	145.04
	L1	130.64	130.64	130.64	145.04	145.04	159.44	159.44
	K	0.00	0.00	0.00	0.00	0.00	0.00	0.00
	LT	130.64	130.64	130.64	145.04	145.04	159.44	159.44
	L2	116.24	116.24	116.24	130.64	130.64	145.04	145.04
	L1	130.64	130.64	130.64	145.04	145.04	159.44	159.44
	K	14.40	14.40	14.40	14.40	14.40	14.40	14.40
	LT	130.64	130.64	130.64	145.04	145.04	159.44	159.44
	L2	101.85	101.85	101.85	116.24	116.24	130.64	130.64
	L1	145.04	145.04	145.04	159.44	159.44	173.83	173.83
	L11	28.80	28.80	28.80	43.19	43.19	57.59	57.59
	LT	145.04	145.04	145.04	159.44	159.44	173.83	173.83
	L2	101.85	101.85	101.85	116.24	116.24	130.64	130.64
	L1	159.44	159.44	159.44	173.83	173.83	188.22	188.22
	L11	28.80	28.80	28.80	43.19	43.19	57.59	57.59
	LT	159.44	159.44	159.44	173.83	173.83	188.22	188.22
	L2	87.45	87.45	87.45	101.85	101.85	116.24	116.24
	L1	116.24	116.24	116.24	130.64	130.64	145.04	145.04
	L11	28.80	28.80	28.80	43.19	43.19	57.59	57.59
	LT	116.24	116.24	116.24	130.64	130.64	145.04	145.04
	L2	116.24	116.24	116.24	130.64	130.64	145.04	145.04
	L1	87.45	87.45	87.45	101.85	101.85	116.24	116.24
	L11	57.59	57.59	57.59	71.99	71.99	86.39	86.39
	LT	116.24	116.24	116.24	130.64	130.64	145.04	145.04
	L2	116.24	116.24	116.24	130.64	130.64	145.04	145.04
	L1	87.45	87.45	87.45	101.85	101.85	116.24	116.24
	L11	57.59	57.59	57.59	71.99	71.99	86.39	86.39
	LT	116.24	116.24	116.24	130.64	130.64	145.04	145.04
	L2	145.04	145.04	145.04	159.44	159.44	173.83	173.83
	L1	116.24	116.24	116.24	130.64	130.64	145.04	145.04
	L11	14.40	14.40	14.40	14.40	14.40	14.40	14.40
	LT	145.04	145.04	145.04	159.44	159.44	173.83	173.83
	L2	145.04	145.04	145.04	159.44	159.44	173.83	173.83
	L1	145.04	145.04	145.04	159.44	159.44	173.83	173.83
	L11	14.40	14.40	14.40	14.40	14.40	14.40	14.40
	LT	145.04	145.04	145.04	159.44	159.44	173.83	173.83
	L2	116.24	116.24	116.24	130.64	130.64	145.04	145.04
	L1	145.04	145.04	145.04	159.44	159.44	173.83	173.83
	K	0.00	0.00	0.00	0.00	0.00	0.00	0.00
	LT	145.04	145.04	145.04	159.44	159.44	173.83	173.83
	L2	145.04	145.04	145.04	159.44	159.44	173.83	173.83
	L1	116.24	116.24	116.24	130.64	130.64	145.04	145.04
	L11	14.40	14.40	14.40	14.40	14.40	14.40	14.40
	LT	145.04	145.04	145.04	159.44	159.44	173.83	173.83

\* Include Droplet Eliminator after Cooling Coil



# AVS 85-380 WITH ENERGY WHEEL

Rated parameters		Recommended range of airflow																					
Size		AVS085			AVS100			AVS130			AVS170			AVS230			AVS300			AVS380			
60 000	[CFM]																						
40 000																							
20 000																							
0																							
Min.		4 069	4 069	4 069	4 501	4 501	4 501	4 979	5 183	5 183	7 630	7 630	7 630	10 427	10 427	10 427	12 165	12 165	12 165	15 526	15 526	15 526	
Max.		15 121	13 198	9 724	15 122	16 026	11 809	21 698	19 997	14 513	23 578	26 348	19 414	32 704	35 609	26 238	45 678	43 761	32 245	48 968	58 255	42 924	
H <sub>fd</sub>		3.54																					
H <sub>fu</sub>		0.00																					
H		46.57			54.21			54.21			65.98			75.16			75.16			93.94			
W		82.87			82.87			98.94			102.56			122.24			141.93			146.34			
W <sub>i</sub>		78.94			78.94			95.00			98.62			118.31			137.99			142.4			
H <sub>i</sub>		39.09			47.13			47.13			58.9			68.07			68.07			86.85			
H <sub>2</sub>		89.61			107.64			107.64			131.18			149.53			149.53			187.09			

Main configuration DE*		Basic configurations													
AVS-XXX-R-R	L2	116.24	101.85	101.85	116.24	116.24	116.24	116.24	116.24	116.24	116.24	116.24	116.24	116.24	116.24
	L1	116.24	101.85	101.85	116.24	116.24	116.24	116.24	116.24	116.24	116.24	116.24	116.24	116.24	116.24
	L11	57.59	43.19	43.19	57.59	57.59	57.59	57.59	57.59	57.59	57.59	57.59	57.59	57.59	57.59
AVS-XXX-R-RH	L2	116.24	101.85	101.85	116.24	116.24	116.24	116.24	116.24	116.24	116.24	116.24	116.24	116.24	116.24
	L1	116.24	101.85	101.85	116.24	116.24	116.24	116.24	116.24	116.24	116.24	116.24	116.24	116.24	116.24
	L11	57.59	43.19	43.19	57.59	57.59	57.59	57.59	57.59	57.59	57.59	57.59	57.59	57.59	57.59
AVS-XXX-R-RHCH	L2	116.24	101.85	101.85	116.24	116.24	116.24	116.24	116.24	116.24	116.24	116.24	116.24	116.24	116.24
	L1	116.24	101.85	101.85	116.24	116.24	116.24	116.24	116.24	116.24	116.24	116.24	116.24	116.24	116.24
	L11	71.99	57.59	57.59	71.99	71.99	71.99	71.99	71.99	71.99	71.99	71.99	71.99	71.99	71.99
AVS-XXX-R-RMH	L2	159.44	145.04	145.04	159.44	159.44	159.44	159.44	159.44	159.44	159.44	159.44	159.44	159.44	159.44
	L1	173.83	159.44	159.44	173.83	173.83	173.83	173.83	173.83	173.83	173.83	173.83	173.83	173.83	173.83
	K	0.00	0.00	0.00	0.00	0.00	0.00	0.00	0.00	0.00	0.00	0.00	0.00	0.00	0.00
AVS-XXX-R-RMCH	L2	173.83	159.44	159.44	173.83	173.83	173.83	173.83	173.83	173.83	173.83	173.83	173.83	173.83	173.83
	L1	159.44	145.04	145.04	159.44	159.44	159.44	159.44	159.44	159.44	159.44	159.44	159.44	159.44	159.44
	K	14.40	14.40	14.40	14.40	14.40	14.40	14.40	14.40	14.40	14.40	14.40	14.40	14.40	14.40
AVS-XXX-R-RC	L2	116.24	101.85	101.85	116.24	116.24	116.24	116.24	116.24	116.24	116.24	116.24	116.24	116.24	116.24
	L1	130.64	116.24	116.24	130.64	130.64	130.64	130.64	130.64	130.64	130.64	130.64	130.64	130.64	130.64
	L11	57.59	43.19	43.19	57.59	57.59	57.59	57.59	57.59	57.59	57.59	57.59	57.59	57.59	57.59
AVS-XXX-R-RCMCH	L2	116.24	101.85	101.85	116.24	116.24	116.24	116.24	116.24	116.24	116.24	116.24	116.24	116.24	116.24
	L1	130.64	116.24	116.24	130.64	130.64	130.64	130.64	130.64	130.64	130.64	130.64	130.64	130.64	130.64
	L11	71.99	57.59	57.59	71.99	71.99	71.99	71.99	71.99	71.99	71.99	71.99	71.99	71.99	71.99

\* Include Droplet Eliminator after Cooling Coil

Main configuration DE*		Basic configurations													
AVS-XXX-R-RMC	L2	159.44	145.04	145.04	159.44	159.44	159.44	159.44	159.44	159.44	159.44	159.44	159.44	159.44	159.44
	L1	173.83	159.44	159.44	173.83	173.83	173.83	173.83	173.83	173.83	173.83	173.83	173.83	173.83	173.83
	K	0.00	0.00	0.00	0.00	0.00	0.00	0.00	0.00	0.00	0.00	0.00	0.00	0.00	0.00
AVS-XXX-R-RMCH	L2	173.83	159.44	159.44	173.83	173.83	173.83	173.83	173.83	173.83	173.83	173.83	173.83	173.83	173.83
	L1	159.44	145.04	145.04	159.44	159.44	159.44	159.44	159.44	159.44	159.44	159.44	159.44	159.44	159.44
	K	14.40	14.40	14.40	14.40	14.40	14.40	14.40	14.40	14.40	14.40	14.40	14.40	14.40	14.40
AVS-XXX-R-RHC	L2	145.04	130.64	130.64	145.04	145.04	145.04	145.04	145.04	145.04	145.04	145.04	145.04	145.04	145.04
	L1	188.23	173.83	173.83	188.23	188.23	188.23	188.23	188.23	188.23	188.23	188.23	188.23	188.23	188.23
	L11	57.59	43.19	43.19	57.59	57.59	57.59	57.59	57.59	57.59	57.59	57.59	57.59	57.59	57.59
AVS-XXX-R-RHCH	L2	116.24	101.85	101.85	116.24	116.24	116.24	116.24	116.24	116.24	116.24	116.24	116.24	116.24	116.24
	L1	145.04	130.64	130.64	145.04	145.04	145.04	145.04	145.04	145.04	145.04	145.04	145.04	145.04	145.04
	L11	57.59	43.19	43.19	57.59	57.59	57.59	57.59	57.59	57.59	57.59	57.59	57.59	57.59	57.59
AVS-XXX-R-RMCH	L2	159.44	145.04	145.04	159.44	159.44	159.44	159.44	159.44	159.44	159.44	159.44	159.44	159.44	159.44
	L1	173.83	159.44	159.44	173.83	173.83	173.83	173.83	173.83	173.83	173.83	173.83	173.83	173.83	173.83
	K	0.00	0.00	0.00	0.00	0.00	0.00	0.00	0.00	0.00	0.00	0.00	0.00	0.00	0.00
AVS-XXX-R-RMCHC	L2	188.23	173.83	173.83	188.23	188.23	188.23	188.23	188.23	188.23	188.23	188.23	188.23	188.23	188.23
	L1	159.44	145.04	145.04	159.44	159.44	159.44	159.44	159.44	159.44	159.44	159.44	159.44	159.44	159.44
	L11	14.40	14.40	14.40	14.40	14.40	14.40	14.40	14.40	14.40	14.40	14.40	14.40	14.40	14.40

\* Include Droplet Eliminator after Cooling Coil



# DIMENSIONS -AVS 12 - 65 WITH ENERGY WHEEL

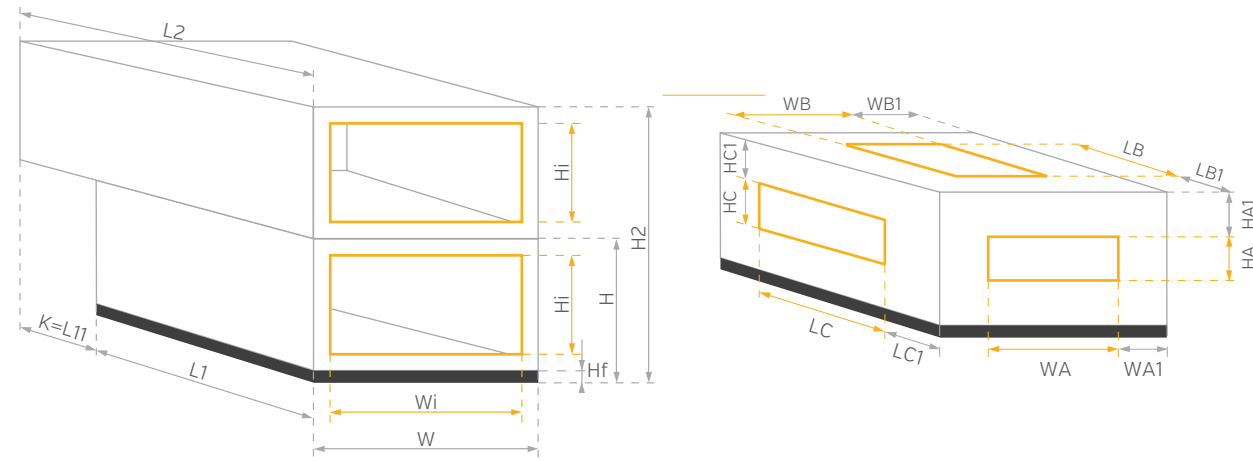

## AIR INLET / DISCHARGE DIMENSIONS

END FULL (FF)					END (FS)				
UNIT	WA	HA	WA1	HA1	UNIT	WA	HA	WA1	HA1
AVS 012	32.32	12.13	3.15	3.15	AVS 012	25.97	7.97	6.34	5.24
AVS 016	37.91	14.17	3.15	3.15	AVS 016	33.97	7.97	5.16	6.26
AVS 020	40.47	17.32	3.15	3.15	AVS 020	25.97	11.97	10.43	5.83
AVS 030	47.20	22.64	3.15	3.15	AVS 030	33.97	11.97	9.80	8.50
AVS 040	52.76	27.36	3.15	3.15	AVS 040	40.51	17.36	9.29	8.19
AVS 055	59.84	31.30	3.15	3.15	AVS 055	47.24	22.68	9.47	7.48
AVS 065	68.94	32.76	3.15	3.15	AVS 065	47.24	22.68	14.02	8.23

Side (BS)				
UNIT	HC	LC	HC1	LC1
AVS 012	10.94	7.94	4.33	3.74
AVS 016	12.94	7.94	4.33	3.74
AVS 020	15.94	11.94	4.33	3.82
AVS 030	20.94	11.94	4.33	3.98
AVS 040	16.26	14.96	6.89	8.70
AVS 055	24.13	14.96	6.89	6.73
AVS 065	24.13	14.96	6.89	7.46

## UNIT CODING

AVS - XX

AVS - type of AHU family  
XXX - size of unit (equal to the rated air flow in cfm\*0.001)  
R/L - inspection side (R- right, L -left)  
PHC - symbols of main thermodynamic functions (basic functions)  
Length depends on AHU equipment



# DIMENSIONS -AVS 85-380 WITH ENERGY WHEEL

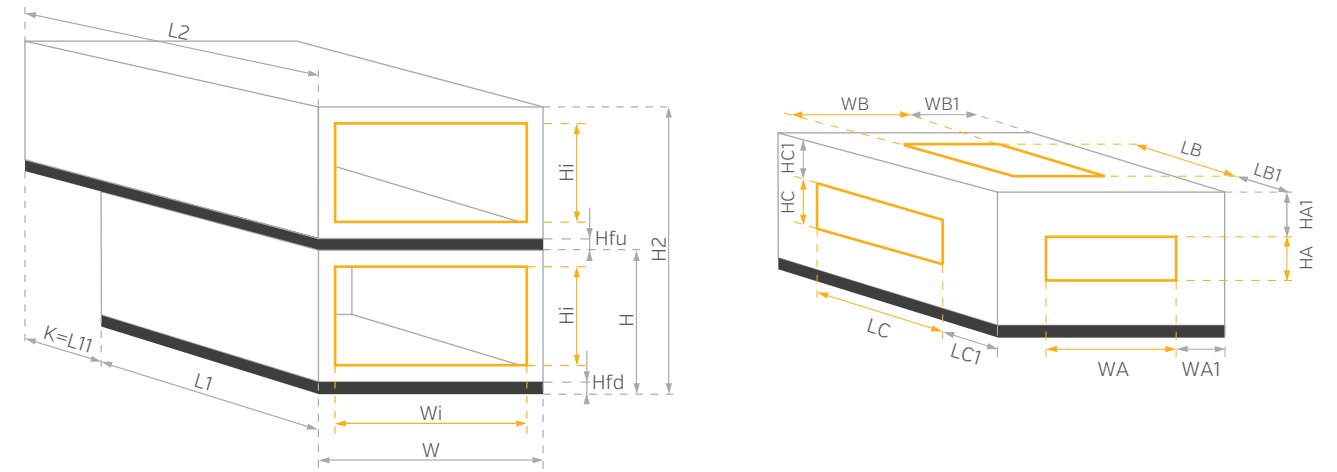

## AIR INLET / DISCHARGE DIMENSIONS

END FULL (FF)					END (FS)				
UNIT	WA	HA	WA1	HA1	UNIT	WA	HA	WA1	HA1
AVS 085	76.57	36.73	3.15	3.15	AVS 085	59.88	31.34	11.52	5.87
AVS 100	76.57	44.76	3.15	3.15	AVS 100	59.88	31.34	11.52	9.88
AVS 130	92.64	44.76	3.15	3.15	AVS 130	76.61	36.77	11.18	7.17
AVS 170	96.26	56.54	3.15	3.15	AVS 170	76.61	36.77	12.99	13.07
AVS 230	115.94	65.71	3.15	3.15	AVS 230	104.37	36.77	8.96	17.64
AVS 300	135.63	65.71	3.15	3.15	AVS 300	124.06	36.77	8.96	17.64
AVS 380	140.04	84.49	3.15	3.15	AVS 380	127.99	36.77	9.19	27.05

Side (BS)				
UNIT	HC	LC	HC1	LC1
AVS 085	28.07	29.13	6.89	7.48
AVS 100	35.94	29.13	6.89	7.56
AVS 130	35.94	29.13	6.89	7.56
AVS 170	47.76	29.13	6.89	7.54
AVS 230	59.57	29.13	6.89	6.22
AVS 300	59.57	29.13	6.89	6.22
AVS 380	75.31	29.13	6.89	7.74

## UNIT CODING

AVS - XX

AVS - type of AHU family  
XXX - size of unit (equal to the rated air flow in cfm\*0.001)  
R/L - inspection side (R- right, L -left)  
PHC - symbols of main thermodynamic functions (basic functions)  
Length depends on AHU equipment



# AVS - VERTICAL CONFIGURATIONS

Rated parameters		Recommended range of airflow																																															
Size		AVS 008				AVS 012				AVS 016				AVS 020				AVS 030				AVS 040																											
15 000	[CFM]	[Bar chart showing airflow ranges for each unit size]																																															
10 000		[Bar chart showing airflow ranges for each unit size]																																															
5 000		[Bar chart showing airflow ranges for each unit size]																																															
0		[Bar chart showing airflow ranges for each unit size]																																															
Min.		[Bar chart showing airflow ranges for each unit size]																																															
Max.		332	427	427	427	480	618	618	618	636	819	819	819	806	1037	1037	1037	1185	1524	1524	1524	1567	1945	1945	1945	2140	1883	1254	924	3091	2719	1817	1339	4096	3605	2486	1832	5186	4564	3331	2454	7622	6708	4835	3563	10078	8559	6697	4934
H <sub>fd</sub>		3.54																																															
H <sub>fu</sub>		0.00																																															
H		21.97	21.97	21.97	21.97	21.97	21.97	21.97	21.97	24.02	24.02	24.02	24.02	27.17	27.17	27.17	27.17	32.48	32.48	32.48	32.48	37.20	37.20	37.20	37.20	37.20	37.20	37.20	37.20	37.20	37.20	37.20	37.20	37.20	37.20	37.20	37.20	37.20	37.20	37.20	37.20								
W		27.95	27.95	27.95	27.95	38.62	38.62	38.62	38.62	44.21	44.21	44.21	44.21	46.77	46.77	46.77	46.77	53.50	53.50	53.50	53.50	59.06	59.06	59.06	59.06	59.06	59.06	59.06	59.06	59.06	59.06	59.06	59.06	59.06	59.06	59.06	59.06												
W <sub>i</sub>		24.02	24.02	24.02	24.02	34.68	34.68	34.68	34.68	40.28	40.28	40.28	40.28	42.83	42.83	42.83	42.83	49.57	49.57	49.57	49.57	55.12	55.12	55.12	55.12	55.12	55.12	55.12	55.12	55.12	55.12	55.12	55.12	55.12	55.12	55.12	55.12												
H <sub>ui</sub>		19.69	19.69	19.69	19.69	19.69	19.69	19.69	19.69	19.69	19.69	19.69	19.69	25.00	25.00	25.00	25.00	25.00	25.00	25.00	25.00	29.72	29.72	29.72	29.72	29.72	29.72	29.72	29.72	29.72	29.72	29.72	29.72																
H <sub>di</sub>		14.49	14.49	14.49	14.49	14.49	14.49	14.49	14.49	16.54	16.54	16.54	16.54	19.69	19.69	19.69	19.69	25.00	25.00	25.00	25.00	29.72	29.72	29.72	29.72	29.72	29.72	29.72	29.72	29.72	29.72	29.72	29.72																
H <sub>2</sub>		45.59	45.59	45.59	45.59	45.59	45.59	45.59	45.59	47.64	47.64	47.64	47.64	56.10	56.10	56.10	56.10	61.42	61.42	61.42	61.42	70.87	70.87	70.87	70.87	70.87	70.87	70.87	70.87	70.87	70.87	70.87	70.87																

		Basic configurations					
	L2	29.86	29.86	29.86	29.86	29.86	29.86
	L1	29.86	29.86	29.86	29.86	29.86	29.86
	L2	29.86	29.86	29.86	29.86	29.86	29.86
	L1	29.86	29.86	29.86	29.86	29.86	29.86
	L2	29.86	29.86	29.86	29.86	29.86	29.86
	L1	29.86	29.86	29.86	29.86	29.86	29.86
	L2	29.86	29.86	29.86	29.86	29.86	29.86
	L1	29.86	29.86	29.86	29.86	29.86	29.86
	L2	29.86	29.86	29.86	29.86	29.86	29.86
	L1	58.65	58.65	58.65	58.65	58.65	58.65
	L2	29.86	29.86	29.86	29.86	29.86	29.86
	L1	58.65	58.65	58.65	58.65	58.65	58.65
	L2	29.86	29.86	29.86	29.86	29.86	29.86
	L1	58.65	58.65	58.65	58.65	58.65	58.65
	L2	29.86	29.86	29.86	29.86	29.86	29.86
	L1	58.65	58.65	58.65	58.65	58.65	58.65



# DIMENSIONS

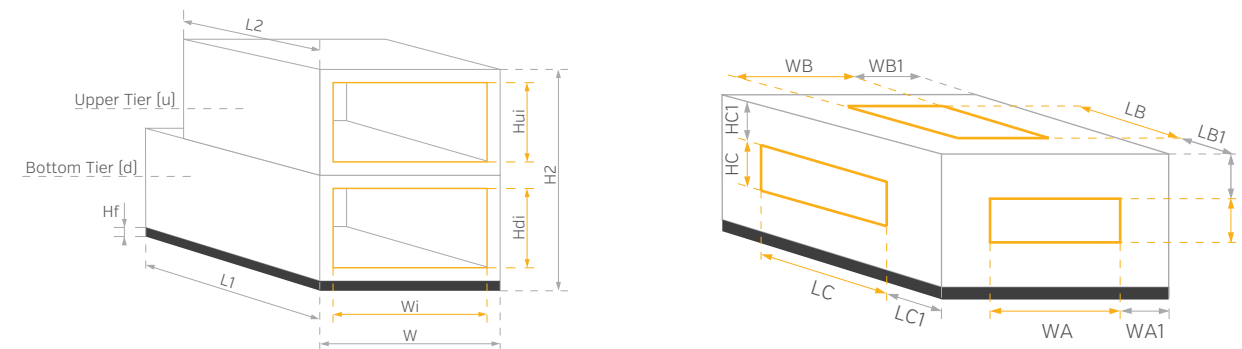

## AIR INLET / DISCHARGE DIMENSIONS

END FULL (FF)				
Unit	WA	HA	WA1	HA1
AVS008	21.63	17.31	3.13	3.13
AVS012	32.31	17.31	3.13	3.13
AVS016	37.94	17.31	3.13	3.13
AVS020	40.50	22.63	3.13	3.13
AVS030	47.19	22.63	3.13	3.13
AVS 040	52.75	27.38	3.13	3.13

END FULL (FF)				
Unit	WA	HA	WA1	HA1
AVS008	21.31	11.81	3.28	3.28
AVS012	32.00	11.81	3.28	3.28
AVS016	37.62	13.86	3.28	3.28
AVS020	40.19	17.01	3.28	3.28
AVS030	46.87	22.32	3.28	3.28
AVS 040	52.44	27.05	3.28	3.28

END (FS)				
Unit	WA	HA	WA1	HA1
AVS008	18.00	8.00	4.60	11.12
AVS012	26.00	8.00	5.90	11.12
AVS016	34.00	8.00	4.70	10.62
AVS020	26.00	12.00	10.00	11.94
AVS030	34.00	12.00	9.40	11.94
AVS 040	48.00	12.00	5.10	16.66

END (FS)				
Unit	WA	HA	WA1	HA1
AVS008	17.94	7.94	4.66	4.84
AVS012	25.94	7.94	5.91	4.84
AVS016	33.94	7.94	4.72	5.84
AVS020	25.94	11.94	10.03	5.41
AVS030	33.94	11.94	9.41	8.16
AVS 040	40.50	17.31	9.28	8.22

TOP (US)				
Unit	WB	LB	WB1	LB1
AVS008	18.00	8.00	4.60	10.90
AVS012	26.00	8.00	5.90	10.90
AVS016	34.00	8.00	4.70	10.90
AVS020	26.00	12.00	10.00	8.90
AVS030	34.00	12.00	9.40	8.90
AVS 040	48.00	12.00	5.10	8.90

TOP (US)				
Unit	WB	LB	WB1	LB1
AVS008	17.94	7.94	4.66	3.91
AVS012	25.94	7.94	5.91	3.91
AVS016	33.94	7.94	4.72	3.91
AVS020	25.94	11.94	10.03	3.91
AVS030	33.94	11.94	9.41	3.91
AVS 040	40.50	17.31	9.28	7.84

Side (BS)				
Unit	HC	LC	HC1	LC1
AVS008	8.00	11.00	11.12	9.40
AVS012	8.00	11.00	11.12	9.40
AVS016	8.00	13.00	10.62	8.40
AVS020	12.00	16.00	11.94	6.90
AVS030	12.00	21.00	11.94	4.40
AVS 040	12.00	21.00	16.66	4.40

Side (BS)				
Unit	HC	LC	HC1	LC1
AVS008	10.94	7.94	3.34	3.91
AVS012	10.94	7.94	3.34	3.91
AVS016	12.94	7.94	3.34	3.91
AVS020	15.94	11.94	3.41	3.91
AVS030	20.94	11.94	3.66	3.91
AVS 040	16.25	14.94	8.72	6.47

## UNIT CODING

AVS - XXX - R/L - RHC

- AVS - type of AHU family
- XXX - size of unit (equal to the rated air flow in cfm\*0.001)
- R/L - inspection side (R-right, L-left)
- RHC - symbols of main thermodynamic functions (basic functions)
- Length depends on AHU equipment



**04**

Connection and  
controls



# CONNECTING POINT

The Connecting Point is the power supply and VFD Enclosure, the internal wiring system of the air-handling unit related to power supply and control of fan motors. It is mounted separately for the supply and exhaust fan sections.

It consists of a casing, a frequency converter (VFD), surge protection, emergency (service) switch, strip connector, factory-produced internal power circuits, and control wiring of the fan drive system (motor-inverter). In the case of vertical air-handling units, an external wired outlet is mounted on the casing and connected to the Connecting Point.

The Connecting Point is equipped with aggregate terminals for power supply circuits; inverter circuits are factory-connected to these terminals.



# CONSTRUCTION AND WIRING



THE MAIN BENEFITS OF AIR-HANDLING UNITS EQUIPPED WITH THE CONNECTING POINT ARE AS FOLLOWS:

- » the certainty of correctness of internal connections supplying the motor and the VFD
- » reliability of factory-tested connections and air-handling unit operation
- » on-site time-savings on wiring
- » lower costs of the whole installation
- » factory installation of the service switch
- » clear liability of the producer for the connection and configuration of inverters and motors





# CONTROLS

VTS uses control algorithms that have been developed with an emphasis on energy savings, while at the same time maintaining the required parameters of the air supplied and ensuring reliability of our units.

For management of our American VENTUS air handling units we recommend our control application based on PLC controller, supporting all advanced control functions and variable ways of external communication including integration with Building Management Systems.

## NEW FEATURES

### MEASUREMENT AND CONTROL OF THE CONSTANT AIR VOLUME

- » adjustment of the preset constant air volume under changing flow resistance - compensation of changing internal resistance of the AHU (e.g. with varying degrees of air filter dirt, different setpoint of the mixing box, etc.)
- » adjustment of the fan power to the current needs of the installation
- » readiness of the AHU to work with the required performance immediately after installation

### CONSTANT PRESSURE CONTROL WITH VARIABLE AIR VOLUME

- » control of constant, preset air pressure at variable volume (efficiency change is carried out through the air distribution system – e.g. VAV controllers)

### CO<sub>2</sub>

- » automatic modulation of the amount of outside air (keeping the CO<sub>2</sub> concentration below the set value)
- » optimisation of consumption of heat and electricity

### ELECTRIC HEATER CONTROL

- » smooth control system that adjusts power to the current demand

### HUMIDITY CONTROL

- » control over air humidifying - both evaporative and steam
- » supports control of the drying process

### MIXING BOX CONTROL

- » smooth control of the mixing box, external signal or as in the CO<sub>2</sub> control function, etc.
- » optimization of the ventilation air to save energy



# MAIN ELEMENTS

## HMI SERVICE



### Function and Application

- » setting and reading of advanced operating parameters of ventilation or supply units
- » management and cancellation of units operational errors is done by full text description
- » management of the controller main calendar

### Operation parameters

- » power supply: directly from the UPC3 controller
- » communication port: serial port, RS485 standard
- » communication cable length: max. 3,600ft
- » connection method: 1:1
- » protection class: NEMA 2
- » ambient temperature: -4 ÷ +140°F / φ<85%, without condensation

## VARIABLE FREQUENCY DRIVES



### Function and Application

- » smooth regulation of the AHU air flow by proportional change of the motor-fan unit rotational speed
- » maintaining fixed AHU operating parameters at varying air flow resistance of the ductworks
- » protection of maximal value of motor current
- » controlling of fan start-up with simultaneous protection of maximal value of start-up current
- » integration with external analog and binary signals
- » displaying and modification of fan-set working parameters

### Operation parameters

- » supply Frequency: 50/60 Hz (48 Hz to 62 Hz)
- » control
  - method: Type of control: V/f (Scalar); VVW: Voltage vector control; PWM SVM (Space Vector Modulation)
  - output Frequency: 0 to 500 Hz, resolution of 0.015 Hz

- » analog Inputs:
  - 1 insulated input. Levels: (0 to 10) V or (0 a 20) mA or (4 to 20) mA
  - programmable functions
- » digital Inputs:
  - 4 insulated inputs
  - programmable functions:
    - Active high (PNP)
    - Active low (NPN)
- » analog Output
  - 1 insulated output. Level (0 to 10) V or (0 to 20) mA or (4 to 20) mA
  - programmable functions
- » relay Output
  - 1 relay with NA/NF contact.
  - maximum voltage: 240 VAC
  - maximum current 0,5 A
  - programmable functions
- » communication Interface RS 485
  - insulated RS485
  - modbus-RTU protocol with maximum communication of 38.4kbps
- » enclosure
  - NEMA1/IP20



## DUCT TEMPERATURE SENSOR

**Function and Application**

- » measurement of the temperature of supply, exhaust and outside air
- » securing max. and min. temperature of supply air
- » protection against frost on the energy recovery unit via the temperature measurement of air exhausted upstream the energy recovery unit

**Operation parameters**

- » measurement range: -40°F -158 °F
- » air humidity: 5 ÷ 100 %
- » measuring element: NTC 10k
- » output signal: resistance
- » cables length: max. 300 ft
- » protection class: IP 54

## DIFFERENTIAL PRESSURE SWITCH

**Function and Application**

- » monitoring the filter contamination in the Air Handling Unit by measuring the difference of static pressure before and after the filter
- » control of the operation of a direct driven fan unit in case of cooperation with electric heater

**Operation parameters**

- » measurement: 0,12÷1,20 in WG – filters of class MERV 6÷15
- » rated operating voltage: 250V AC (Imax=3A)
- » output signal: potential-free contact, NO or NC according to the application
- » switching capacity: 1mln of cycles (at temp. of 140 °F)
- » protection class: NEMA 3
- » ambient temperature: -4 °F ÷ +140 °F

## LOW LIMIT THERMOSTAT SWITCH

**Function and Application**

- » when the air temperature drops below the minimum allowable temperature, signal from the thermostat stops AHU fans, closes external air dampers and adjusts control valve of the heater to the max. flow of heating medium
- » switching into permanent alarm condition if the AHU protection is triggered three times within an hour

**Operation parameters**

- » measurement range: -0.4 ÷ +59 °F
- » default switching threshold setting: 41 °F
- » hysteresis: 1.7 ÷ 12K
- » Rated operating voltage: 30 V DC, 230 VAC
- » output signal: potential-free (switchover contact)
- » protection class: NEMA 3



## THREE-WAY VALVE WITH ELECTRIC ACTUATOR

**Function and Application**

- » temperature adjustment of the medium flowing through the hydronic coil
- » quality hydronic heater capacity regulation (system based on additional recirculation pump)
- » quantity hydronic cooler capacity regulation

**Operation parameters**

- » actuator:
  - adjustment range: 0 -100%
  - supply voltage: 24 V AC/DC
  - input signal: 0-10 V DC
  - rotation angle: 90°
  - protection class: NEMA 2
  - ambient temperature: -22 ÷ +122 °F
- » valve:
  - operating characteristics: Equal percentage/proportional Cv: 3 / 4.7 / 7.4 / 19 / 29 / 46 / 68 / 91
  - differential Pressure: 50 psi for typical applications
  - medium temperature: 0°F ÷ 250°F

## 0-10 V AIR DAMPER ACTUATOR

**Function and Application**

- » mixing ratio control for outdoor and room-exhausted air (economizer): 0-10 V actuator
- » control of bypass air damper opening level for the Plate Cross-Flow – anti-frost protection of the energy recovery system
- » 0-10 V actuator:
  - actuator with spring return
  - economizer fresh air side
- » actuator with no spring return:
  - economizer return air side
  - by-pass damper for cross-plate based energy recovery system

**Operation parameters**

- » regulation method: smooth 0-100%
- » supply voltage: 24 VAC
- » input signal: 0 -10 VDC
- » rated torque: 90 in-lbs
- » rotation angle 90°
- » full opening time: 0 10 V: 80÷90s;
- » spring-forced return: 10s
- » max. air damper area: 43 ft2
- » protection class: NEMA 2
- » ambient temperature: -22 ÷ +122 °F

## HUMIDITY SENSOR

**Function and Application**

- » multiple ranges as measurement windows available
- » innovative self-calibrating algorithm
- » long term stability and accuracy

**Operation parameters**

- » microcontroller based design
- » supply voltage: 24 V AC/DC
- » 1 analogue output (0-10 VDC / 0-20 mA)
- » modbus RTU (RS485) Communication



# CONTROL APPLICATIONS LIST

**AP** - control system application for air supply-exhaust units with cross-flow heat exchanger

Application code	Functions available in particular applications					
	HW	DX	DX	PRC. BPS	MIX. CMBR	SUMMER
AP 32				✓		
AP 41	✓			✓		
AP 33		✓		✓		
AP 36	✓	✓		✓		
AP 37			✓	✓		
AP 40	✓		✓	✓		
AP 160				✓		✓
AP 161	✓			✓		✓
AP 164		✓		✓		✓
AP 165	✓	✓		✓		✓
AP 168			✓	✓		✓
AP 169	✓		✓	✓		✓

**AR** - control system application for air supply-exhaust units with thermal wheel

Application code	Functions available in particular applications					
	HW	DX	DX	PRC. BPS	MIX. CMBR	SUMMER
AP 0						
AP 1	✓					
AP 4		✓				
AP 5	✓	✓				
AP 8			✓			
AP 9	✓		✓			
AP 128						✓
AP 129	✓					✓
AP 132		✓				✓
AP 133	✓	✓				✓
AP 136			✓			✓
AP 137	✓		✓			✓

**AS** - control system application for air supply units

Application code	Functions available in particular applications					
	HW	DX	DX	PRC. BPS	MIX. CMBR	SUMMER
AP 1	✓					
AP 4		✓				
AP 5	✓	✓				
AP 8			✓			
AP 9	✓		✓			
AP 65	✓				✓	
AP 68		✓			✓	
AP 69	✓	✓			✓	
AP 72			✓		✓	
AP 73	✓		✓		✓	
AP 193	✓				✓	✓
AP 196		✓			✓	✓
AP 197	✓	✓			✓	✓
AP 200			✓		✓	✓
AP 201	✓		✓		✓	✓



# SUPPLY AHUS

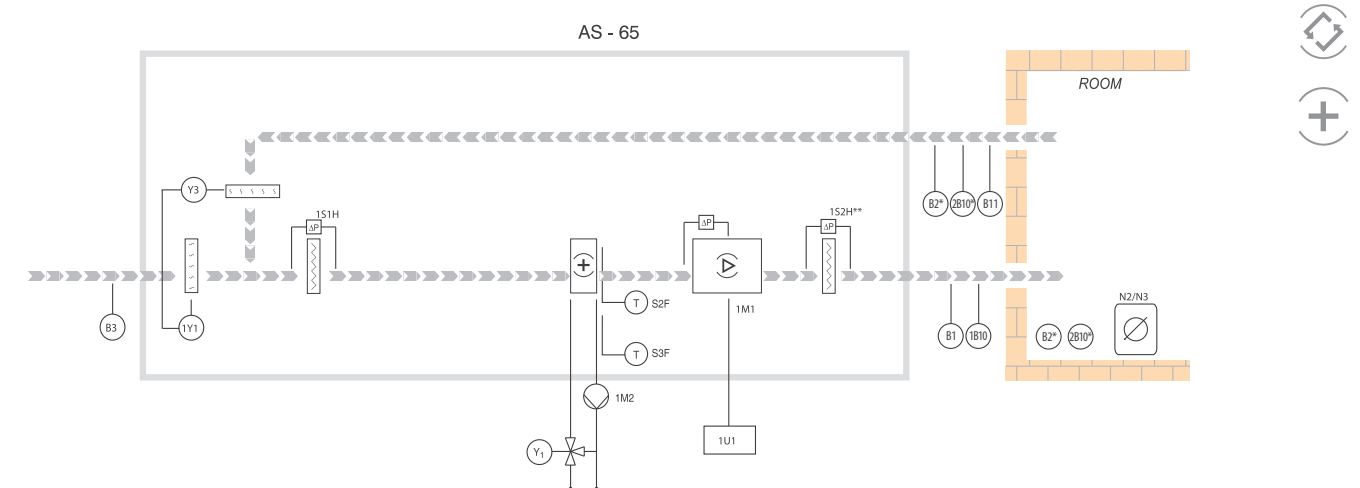
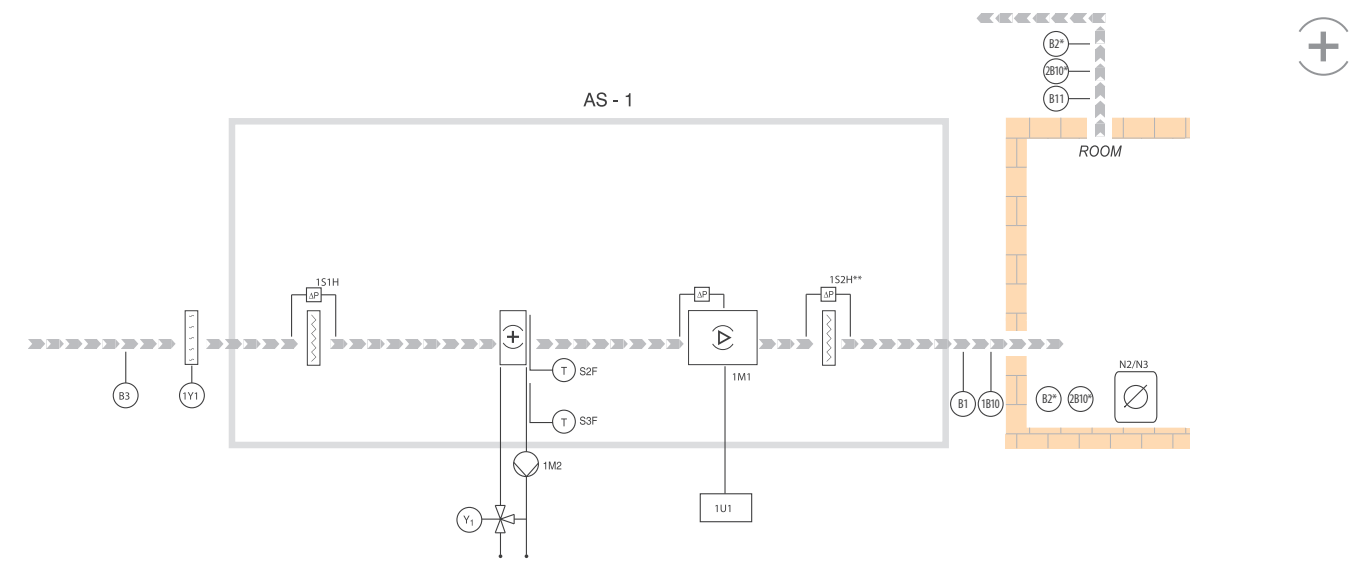

## CONTROL

- » control of room temperature, or supply or exhaust air temperature
  - » control of the energy recovery level – first stage of heating/cooling
  - » air flow control
  - » operation according to calendar – temperature, efficiency, operation mode (OPERATION, STAND-BY, STOP)
  - » STAND-BY – maintaining the minimum, set indoor temperature.
- \* Initial heating of external air

## INFORMATION

- » information on outdoor, supply, exhaust and indoor air temperatures
- » filter contamination info
- » alarm status info
- » analog and digital input and output status info

## PROTECTION

- » limiting the allowed supply air temperature
- » fan unit protection – the function is active: - if an electric heater is present
- » overload protection of a drive unit
- » anti-frost protection of a water heater
- » protection against overheating of an electric heater
- » optional protection against minimal and maximal temperature of medium returning from the water heater with use of Strap-on temperature sensor, standard NTC 10K
- » the control application layouts have been prepared on the basis of water exchangers
- » the quantity of applied pressure switches for filters depends on the filter configuration

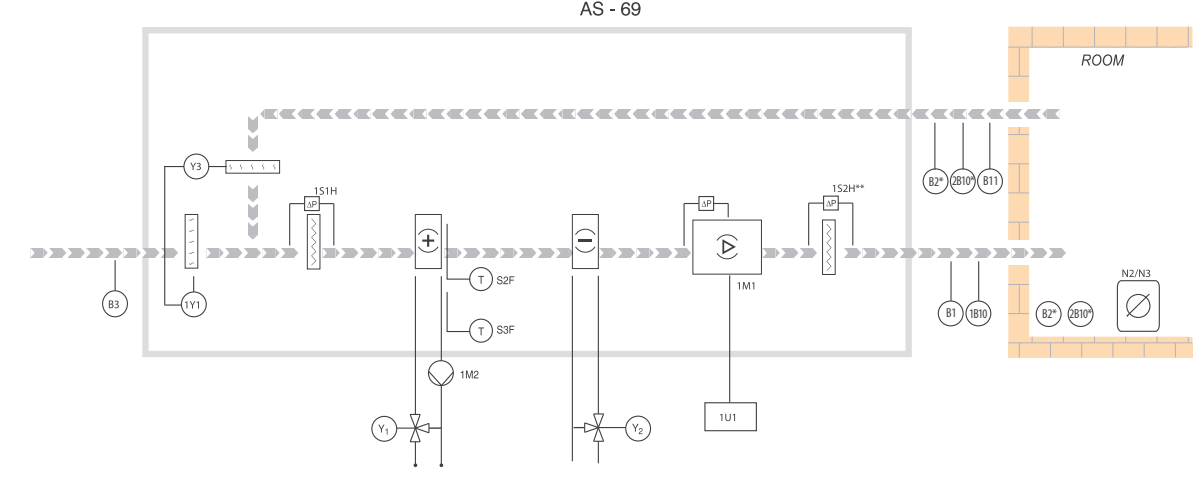
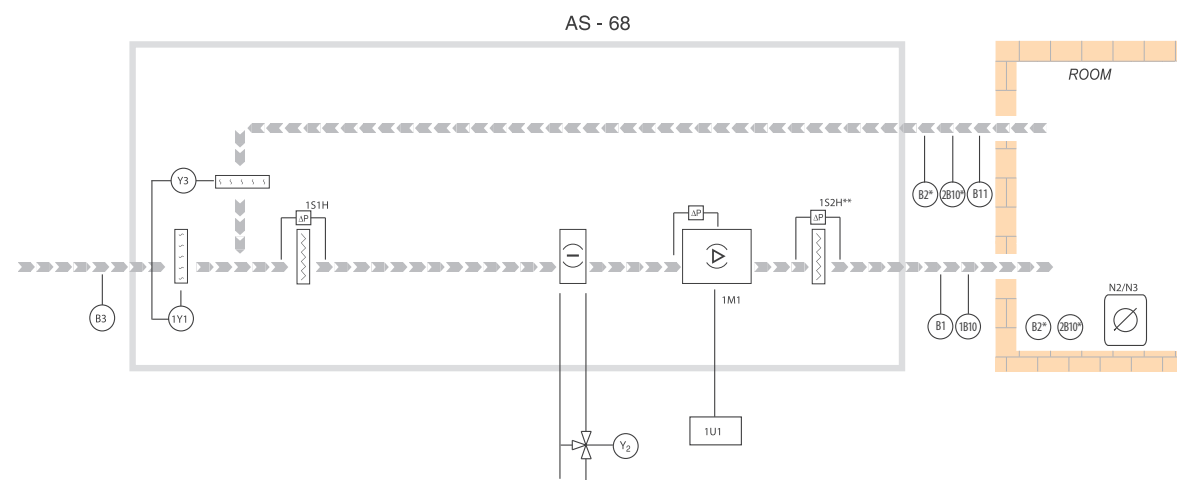
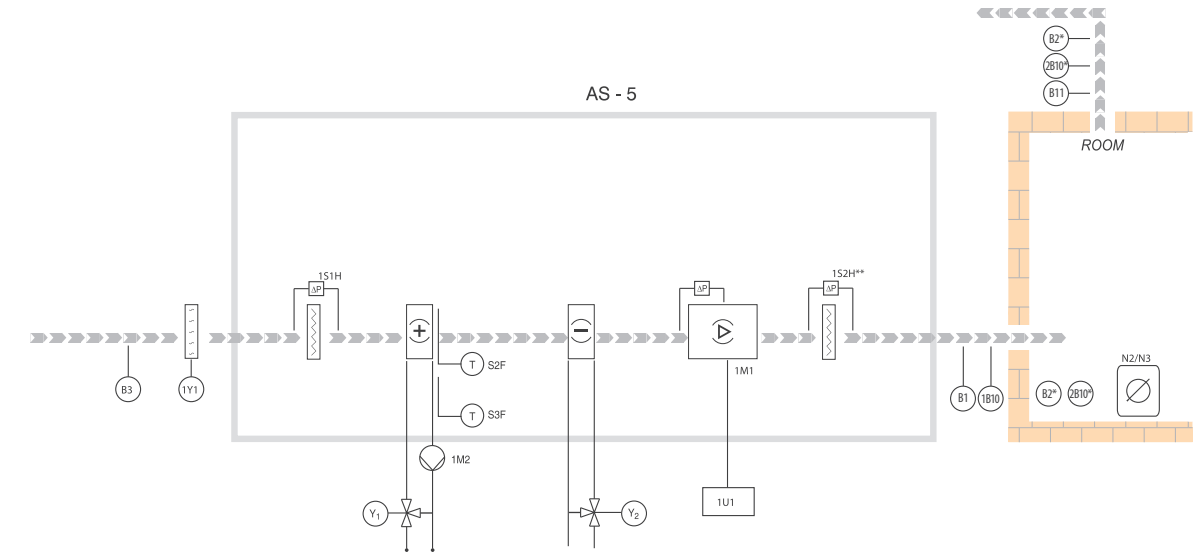
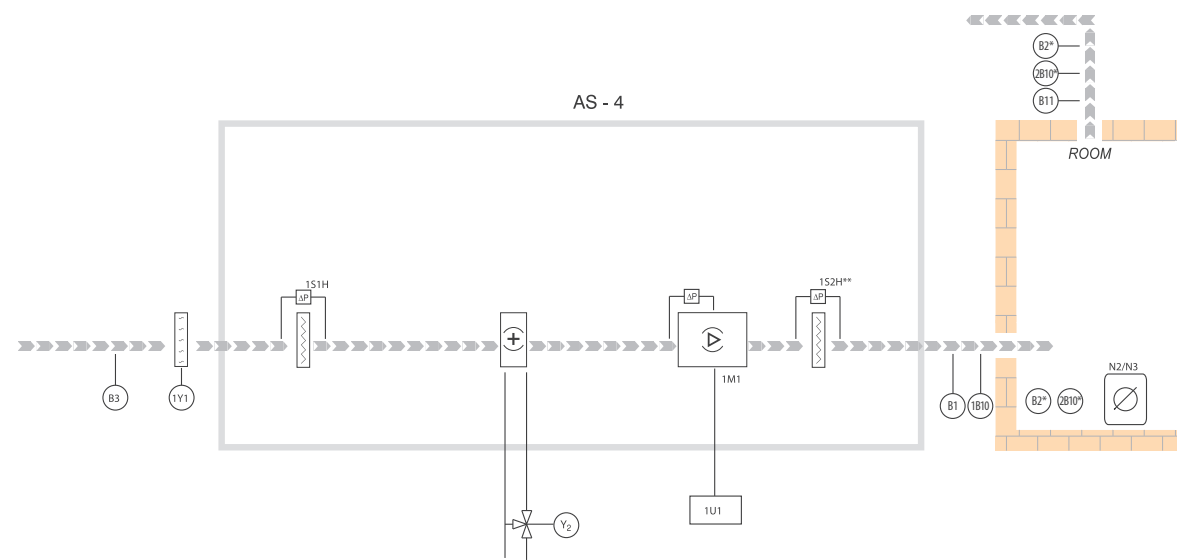

**CONTROL**

- » control of room temperature, optionally supply or exhaust air temperature
  - » control of the energy recovery level – first stage of heating/cooling
  - » air flow control
  - » operation according to calendar – temperature, efficiency, operation mode (OPERATION, STAND-BY, STOP)
  - » STAND-BY – maintaining the minimum, set indoor temperature.
- \* Initial heating of external air.

**INFORMATION**

- » information on outdoor, supply, exhaust and indoor air temperatures
- » filter contamination info
- » alarm status info
- » analog and digital input and output status info

**PROTECTION**

- » limiting the allowed supply air temperature
- » fan unit protection – the function is active:
  - if an electric heater is applied
- » overload protection of a drive unit
- » anti-frost protection of a water heater
- » protection against overheating of an electric heater
- » the control application layouts have been prepared on the basis of water exchangers
- » the quantity of applied pressure switches for filters depends on the filters' configuration

**CONTROL**

- » control of room temperature, optionally supply or exhaust air temperature
  - » control of the energy recovery level – first stage of heating/cooling
  - » air flow control
  - » operation according to calendar – temperature, efficiency, operation mode (OPERATION, STAND-BY, STOP)
  - » STAND-BY – maintaining the minimum, set indoor temperature.
- \* Initial heating of external air.

**INFORMATION**

- » information on outdoor, supply, exhaust and indoor air temperatures
- » filter contamination info
- » alarm status info
- » analog and digital input and output status info

**PROTECTION**

- » limiting the allowed supply air temperature
- » fan unit protection – the function is active:
  - if an electric heater is applied
- » overload protection of a drive unit
- » anti-frost protection of a water heater
- » protection against overheating of an electric heater.
- » the control application layouts have been prepared on the basis of water exchangers
- » the quantity of applied pressure switches for filters depends on the filters' configuration

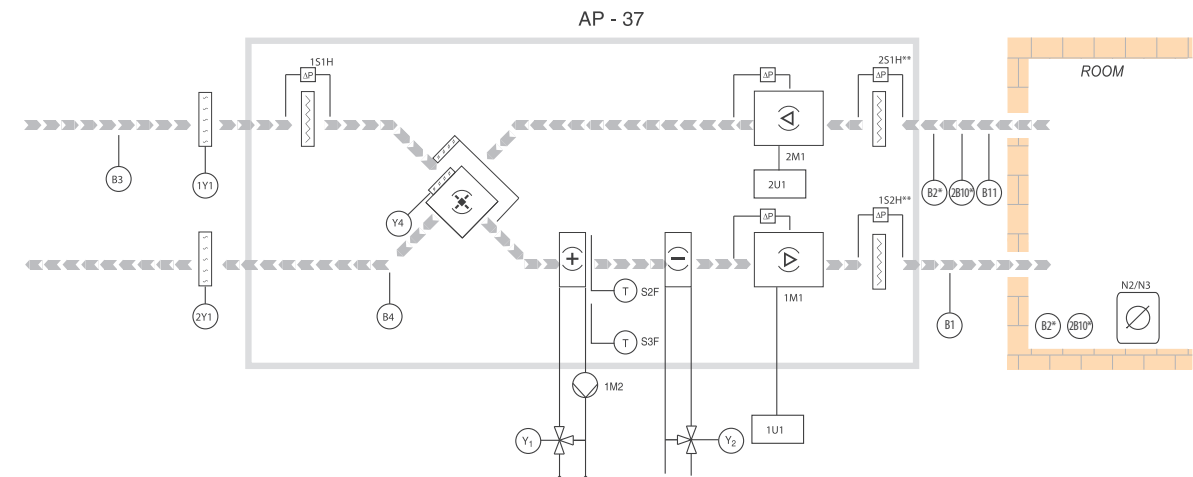
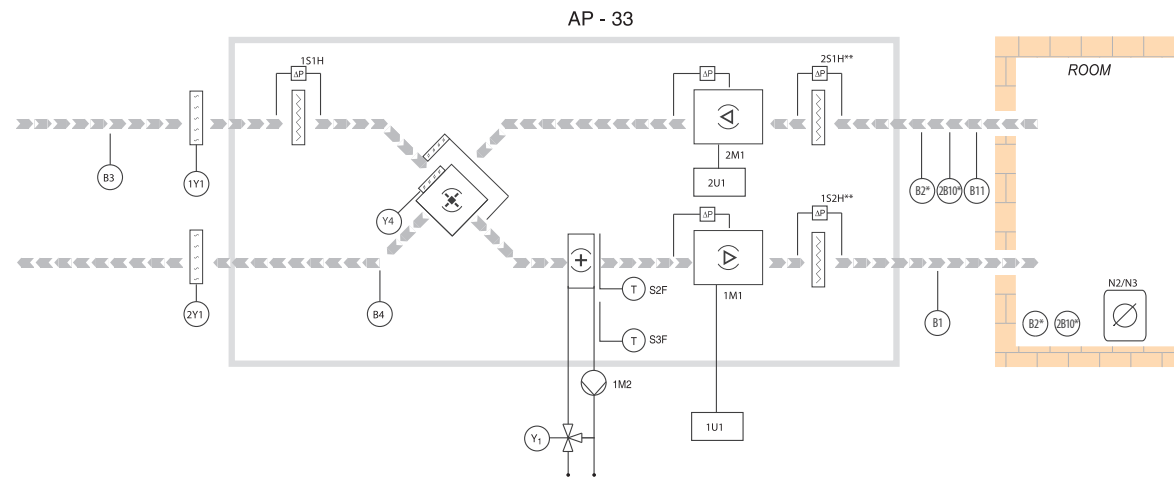
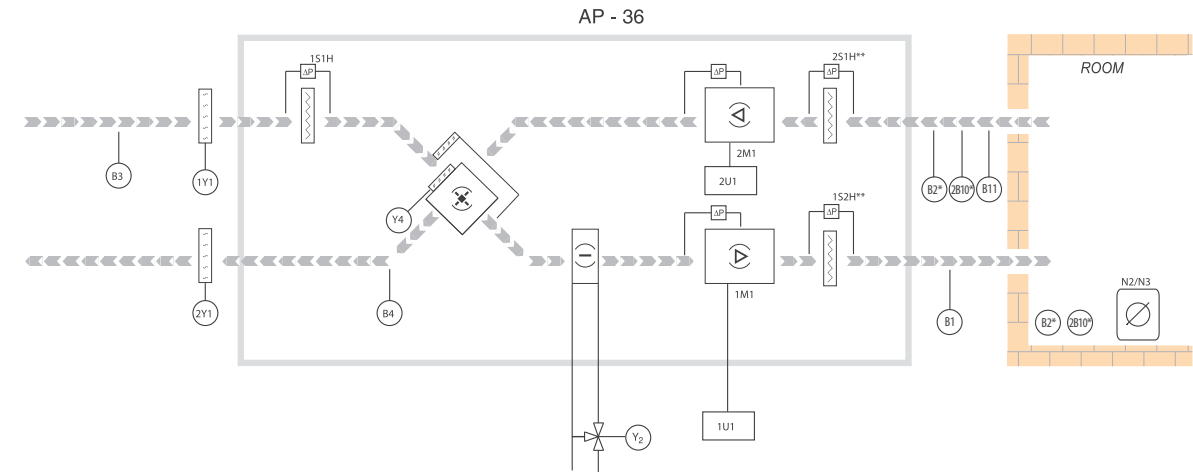
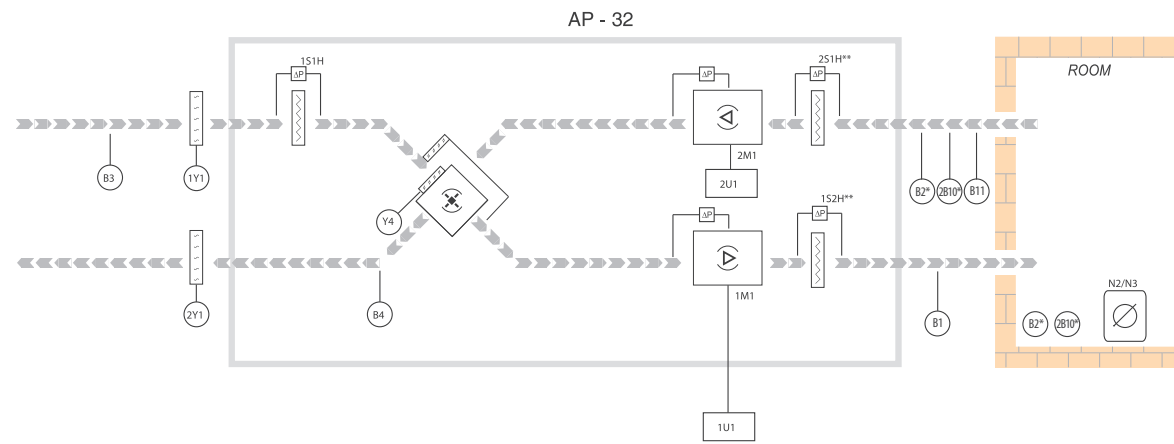

**CONTROL**

- » control of room temperature, optionally supply or exhaust air temperature
- » control of the energy recovery level – first stage of heating/cooling
- » air flow control
- » operation according to calendar – temperature, efficiency, operation mode (OPERATION, STAND-BY, STOP)
- » STAND-BY – maintaining the minimum, set indoor temperature
- \* Initial heating of external air.

**INFORMATION**

- » information on outdoor, supply, exhaust and indoor air temperatures
- » filter contamination info
- » alarm status info
- » analog and digital input and output status info

**PROTECTION**

- » limiting the allowed supply air temperature
- » fan unit protection – the function is active:
  - if an electric heater is applied
- » overload protection of drive unit
- » anti-frost protection of a water heater
- » protection against overheating of an electric heater
- » anti-frost protection of an energy recovery exchanger
- » optional protection against minimal and maximal temperature of medium returning from the water heater with use of Strap-on temperature sensor, standard NTC 10K
- » the control application layouts have been prepared on the basis of water exchangers
- » the quantity of applied pressure switches for filters depends on the filters' configuration
- » optional Strap-on temperature sensor is not a part of VTS offer

**CONTROL**

- » control of room temperature, optionally supply or exhaust air temperature
- » control of the energy recovery level – first stage of heating/cooling
- » air flow control
- » operation according to calendar – temperature, efficiency, operation mode (OPERATION, STAND-BY, STOP)
- » STAND-BY – maintaining the minimum, set indoor temperature
- \* Initial heating of external air.

**INFORMATION**

- » information on outdoor, supply, exhaust and indoor air temperatures
- » filter contamination info
- » alarm status info
- » analog and digital input and output status info

**PROTECTION**

- » limiting the allowed supply air temperature
- » fan unit protection – the function is active:
  - if an electric heater is applied
- » overload protection of a drive unit
- » anti-frost protection of a water heater
- » protection against overheating of an electric heater
- » the control application layouts have been prepared on the basis of water exchangers
- » the quantity of applied pressure switches for filters depends on the filters' configuration

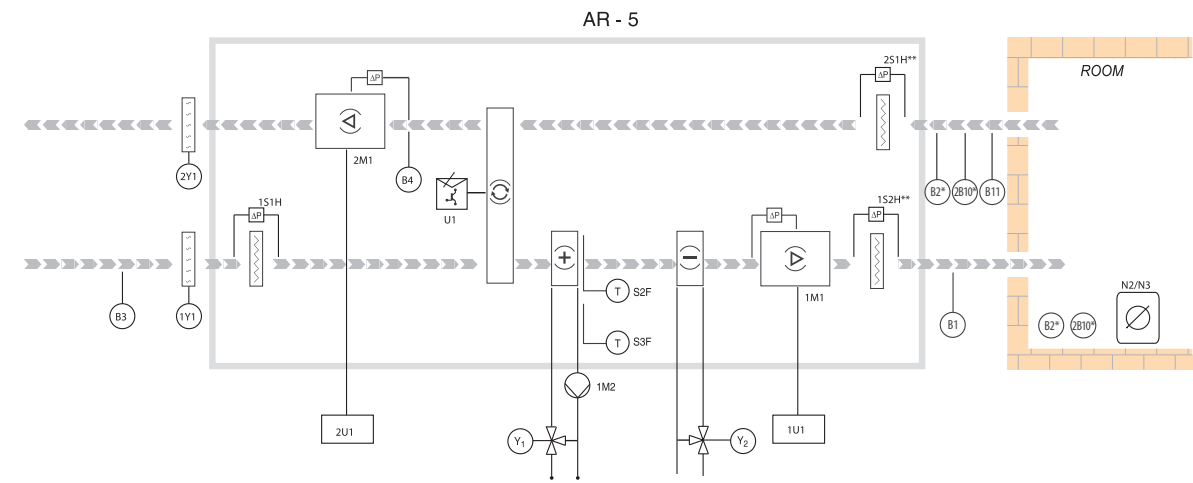
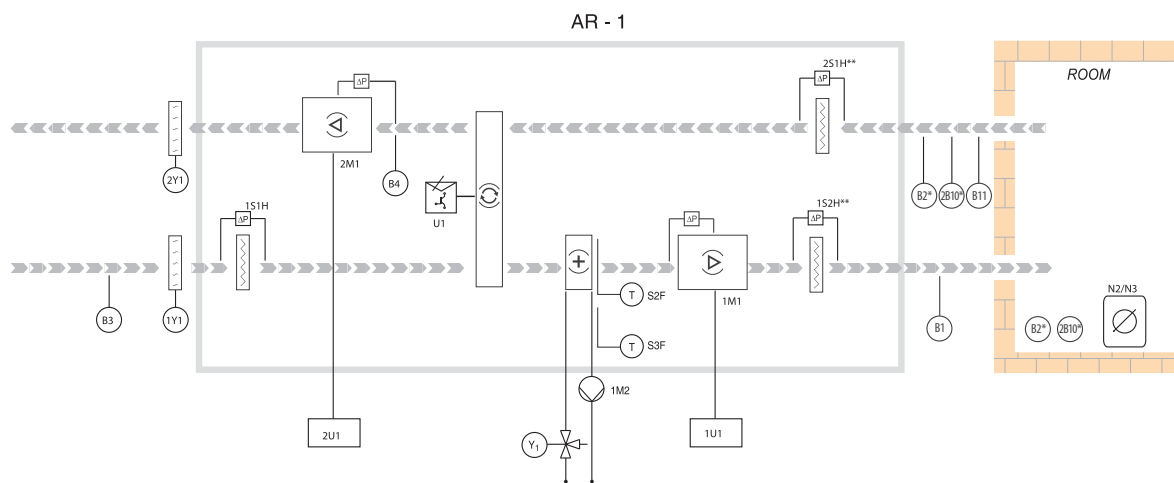
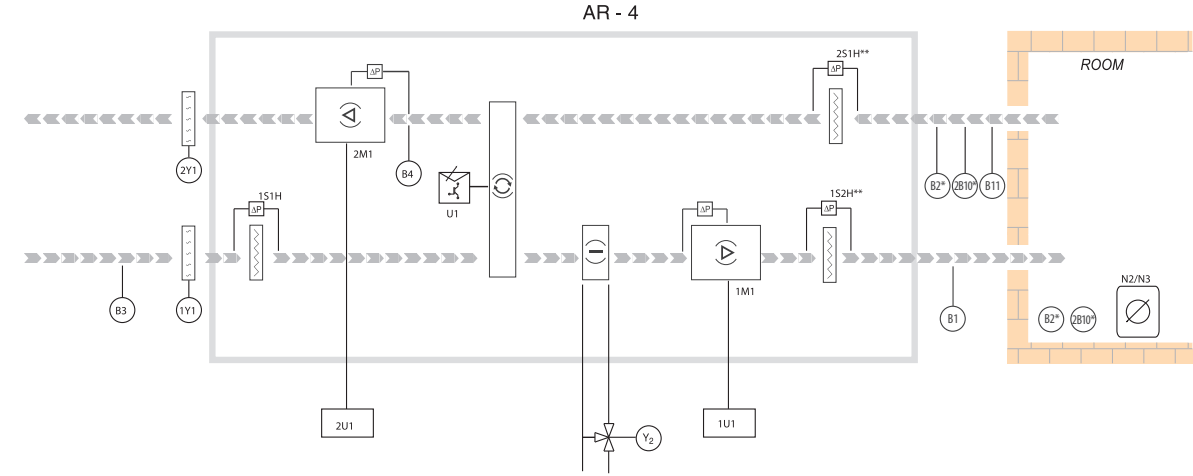
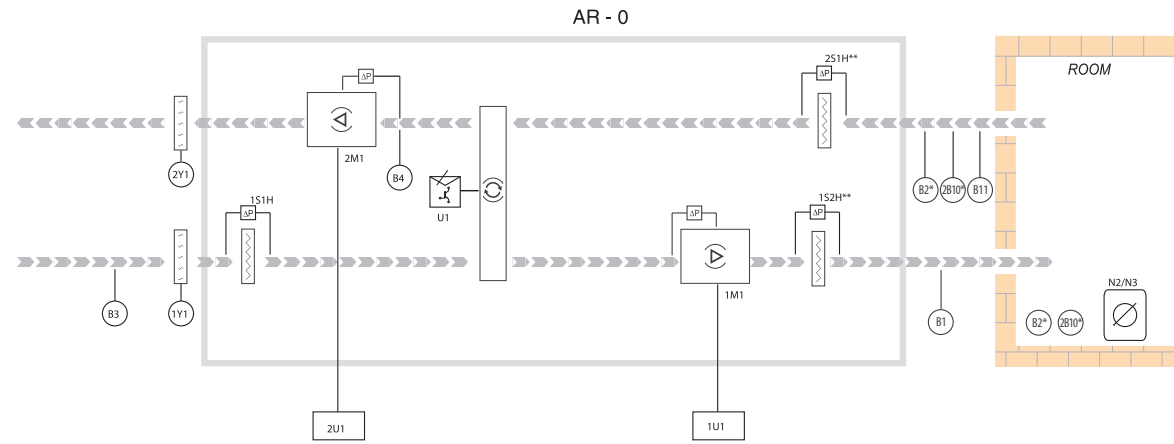

**CONTROL**

- » control of room temperature, optionally supply or exhaust air temperature
  - » control of the energy recovery level – first stage of heating/cooling
  - » air flow control
  - » operation according to calendar – temperature, efficiency, operation mode (OPERATION, STAND-BY, STOP)
  - » STAND-BY – maintaining the minimum, set indoor temperature
- \* Initial heating of external air.

**INFORMATION**

- » information on outdoor, supply, exhaust and indoor air temperatures
- » filter contamination info
- » alarm status info
- » analog and digital input and output status info

**PROTECTION**

- » limiting the allowed supply air temperature
- » fan unit protection – the function is active:
  - if an electric heater is applied
- » overload protection of drive unit
- » anti-frost protection of a water heater
- » protection against overheating of an electric heater
- » anti-frost protection of an energy recovery exchanger
- » optional protection against minimal and maximal temperature of medium returning from the water heater with use of Strap-on temperature sensor, standard NTC 10K
- » the control application layouts have been prepared on the basis of water exchangers
- » the quantity of applied pressure switches for filters depends on the filters' configuration
- » optional Strap-on temperature sensor is not a part of VTS offer

**CONTROL**

- » control of room temperature, optionally supply or exhaust air temperature
  - » control of the energy recovery level – first stage of heating/cooling
  - » air flow control
  - » operation according to calendar – temperature, efficiency, operation mode (OPERATION, STAND-BY, STOP)
  - » STAND-BY – maintaining the minimum, set indoor temperature
- \* Initial heating of external air.

**INFORMATION**

- » information on outdoor, supply, exhaust and indoor air temperatures
- » filter contamination info
- » alarm status info
- » analog and digital input and output status info

**PROTECTION**

- » limiting the allowed supply air temperature
- » fan unit protection – the function is active:
  - if an electric heater is applied
- » overload protection of a drive unit
- » anti-frost protection of a water heater
- » protection against overheating of an electric heater
- » anti-frost protection of an energy recovery exchanger
- » optional protection against minimal and maximal temperature of medium returning from the water heater with use of Strap-on temperature sensor, standard NTC 10
- » the control application layouts have been prepared on the basis of water exchangers
- » the quantity of applied pressure switches for filters depends on the filters' configuration
- » optional Strap-on temperature sensor is not a part of VTS offer

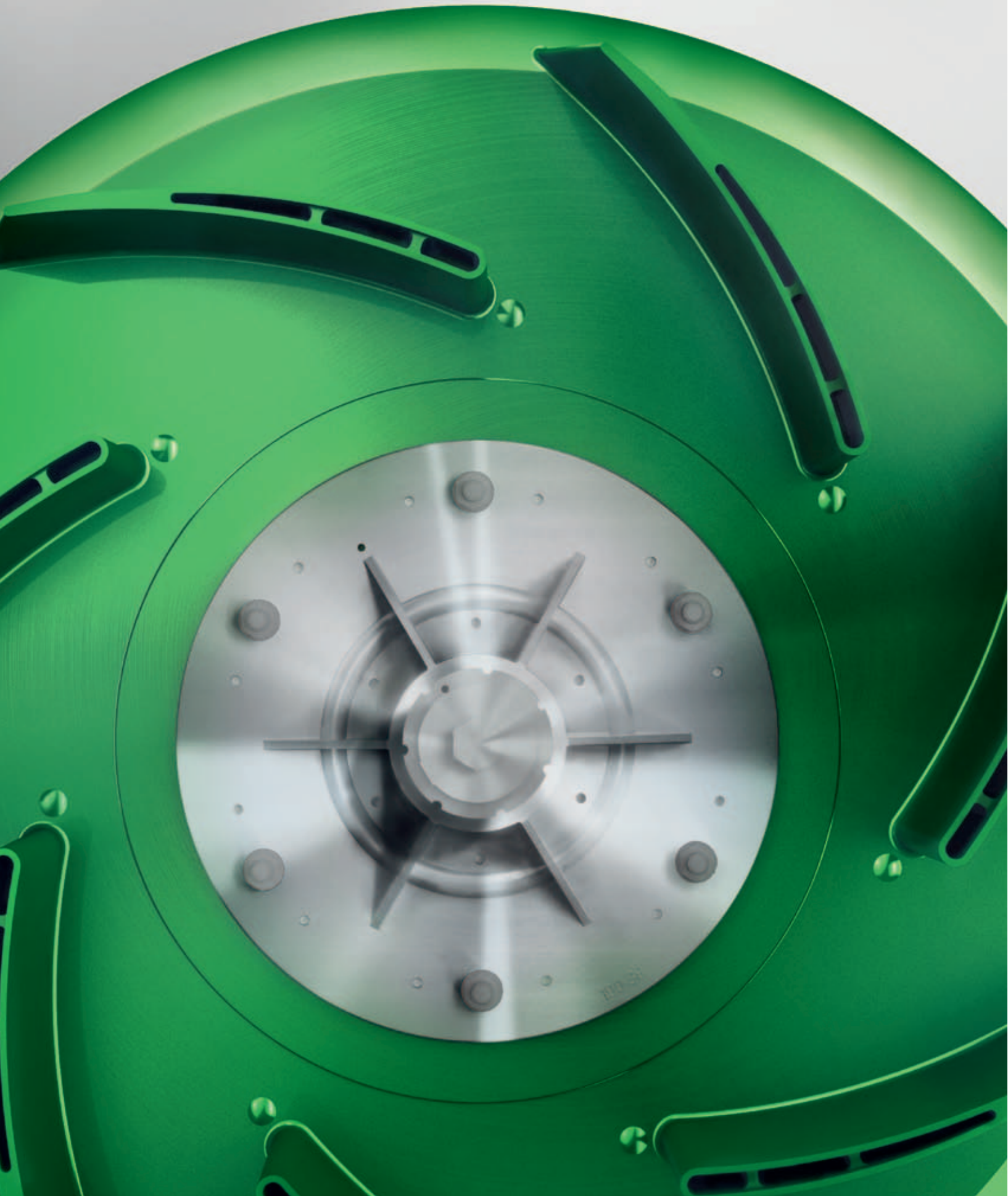

**05**

Functions



### | Direct drive plenum fan

Energy efficient fans are based on single inlet, air foil backward curved radial impellers with 7 blades made of a composite material to minimize the impeller weight and provide the best operating performance. All dynamically balanced.



#### VARIABLE FREQUENCY DRIVE (VFD)

The accurate selection of air flow design and external static pressure with a smooth regulation by proportional change of the motor-fan unit rotational speed. Protection of the maximum value of the motor current, the capability to be integrated with external analog and binary signals and the integration with the BMS system

#### PLENUM FAN MOTOR

Fans are driven by TEFC (Totally Enclosed Fan Cooled) foot mounted motors with double shielded bearings and range from 0.75 HP to 15 HP. Nominal frequency: 60 Hz. Insulation class: F. Efficiency class: Premium. Bearings live: L<sub>10</sub> = 20,000 h, L<sub>50</sub> = 100,000 h. Shaft grounding rings available (on request).

Fan sets used in submitted air handling units are available in a wide range of voltages: 115V/1PH/60Hz, 208V/ 1PH/60Hz, 230V/1PH/60Hz, 208V/3PH/60Hz, 230V/3PH/60Hz, 460V/3PH/60Hz, 575V/3PH.

#### AMCA



VTS Group certifies that the VS fan series shown herein are licensed to bear the AMCA Seal. The ratings shown are based on tests and procedures performed in accordance with AMCA Publication 211 and AMCA Publication 311 and comply with the requirements of the AMCA Certified Ratings Program. The certified ratings for the VS Fans are shown in this catalogue.



### | Air-to-air energy recovery systems

#### AIR-TO-AIR ENERGY WHEEL

The total energy wheel is constructed with 7.9 inch Aluminum coated with non-toxic, non-corrosive Silica gel in a way that allows it to exchange sensible and latent heat between two airstreams, generally outside air and exhaust air. In the cooling mode, the wheel pre-treats the outside air by transferring sensible and latent heat to the exhaust stream. During the heating mode, the wheel pre-treats the outside air with sensible and latent heat from the exhaust air. This energy recovery is done without total separation of the supply and exhaust air flows with air leakages of 2% to 5%.

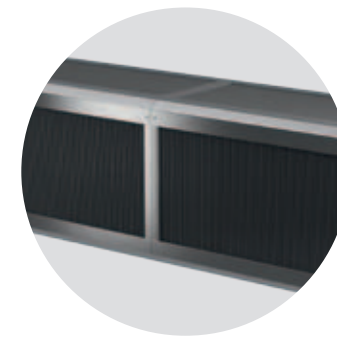

#### CROSS-FLOW PLATE

Cross-Flow plate is an indirect energy recovery device, that transfers heat from the exhaust air stream to the entering air stream which will be supplied to the space. Heat recovery at very high separation of the stream of supply and exhaust air (99.9%). Application in block supply-exhaust AHUs.



#### FLAT PREFILTER

All units have a two or four inches flat prefilter or a combination thereof

- MERV8 two-inch filter.
- MERV13 four-inch filter.





### HEATERS



Heaters are available in the following versions:

- hot water heating coils,
- resistant electric heaters,
- DX heating coils,

The hydronic coil performance is designed in accordance to AHRI Standard 410. All coils are to be counter flow design.

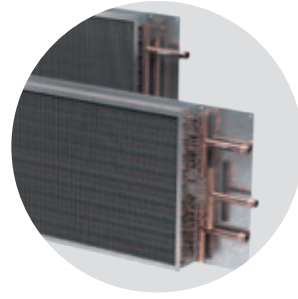
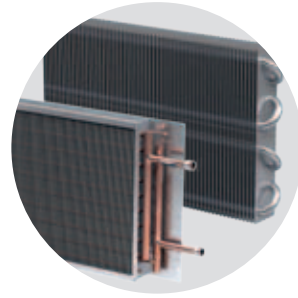

### COOLING COILS



The cooling coils are available either as a hydronic or a DX cooling coils.

The variety of coil types allows a user to select a coil that is optimized for pressure drop and capacity requirements. The cooling coils are mounted over the drainpan to ensure water condensate flowing.

VTS combines comprehensive performance certification by AHRI with thorough laboratory testing and advanced manufacturing methods. Together, these elements help to assure that each VTS product operates predictably and reliably throughout the life of the unit.

Heating and Cooling hydronic coils are rigorously tested and certified in accordance with the forced circulation air cooling and air heating coils certification program based on AHRI Standard 410.

### AIR DAMPERS

VTS Group certifies that the dampers shown herein are licensed to bear the AMCA Seal. The ratings shown are based on tests and procedures performed in accordance with AMCA Publication 511 and comply with the requirements of the AMCA Certified Ratings Program. The AMCA International Certified Ratings Seal applies to Air Performance and Air Leakage. The VTS air dampers are in 3-rd class for 1, 4 and 8 in. w.g.

Leakage testing conducted in accordance with AMCA Standard 500-D-07 figure 5.4 Alternate. Data are based on a torque of 10 in-lb/ft2 applied to close and seal the damper during the test. Air leakage is based on operation between 32 to 120 F. All data corrected to represent standard air density 0.075 lb/ft3.

Pressure drop testing conducted in accordance with AMCA Standard 500-D-07 figure 5.3. All data corrected to represent standard air density 0.075 lb/ft3.

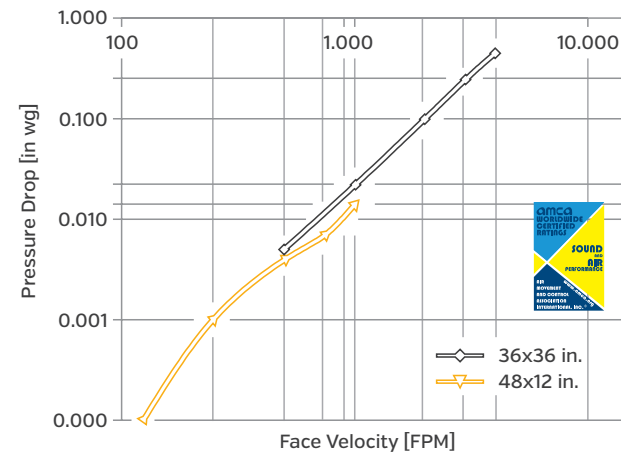
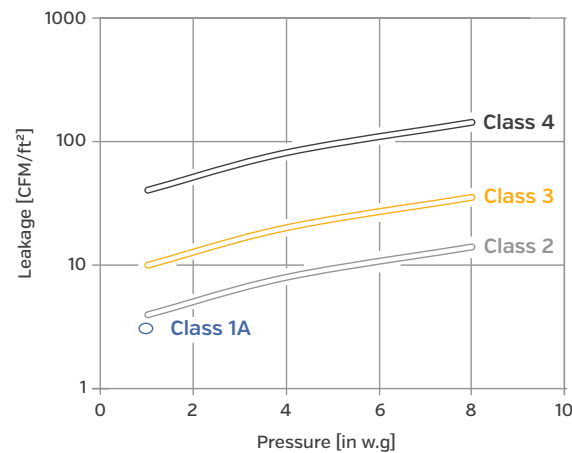

## VTS PSYCHROMETRIC CHART

Normal Temperature  
Barometric Pressure: 29.921 Inches of Mercury  
Sea Level

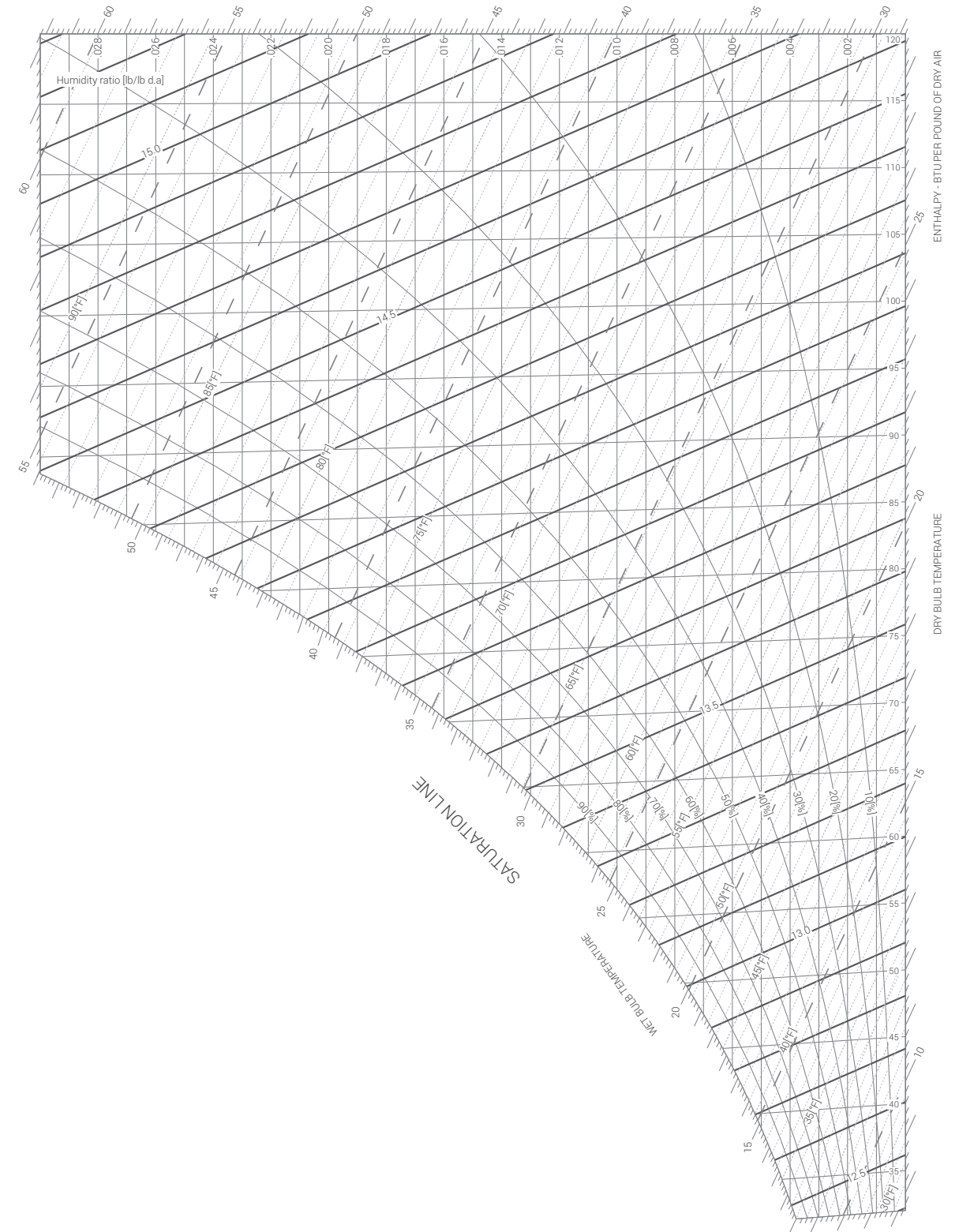



### Certified fan performance data for fans of VS 225-VS 450 sizes

Unit Size	Q (cfm)	Ps (in. wg)	BHP (hp)
VS-225 3450 RPM	1,047	0.004	0.251
	944	0.661	0.277
	841	1.290	0.328
	737	0.195	0.363
	633	2.446	0.374
	522	2.868	0.381
	422	3.056	0.353
	314	3.162	0.300
	158	3.220	0.234
0	3.423	0.158	
VS-250 3450 RPM	1,447	0.015	0.421
	1,300	1.087	0.525
	1,162	2.000	0.645
	1,013	2.892	0.721
	868	3.536	0.747
	720	3.883	0.708
	594	4.065	0.646
	426	4.200	0.537
	283	4.258	0.442
0	4.619	0.250	
VS-315 3450 RPM	3,124	0.011	1.850
	2,824	1.280	2.027
	2,514	2.788	2.244
	2,196	4.281	2.490
	1,887	5.376	2.563
	1,558	6.086	2.485
	1,247	6.391	2.306
	930	6.566	2.059
	529	6.714	1.714
0	7.275	0.945	
VS-355 1750 RPM	2,344	0.001	0.395
	2,119	0.469	0.466
	1,882	0.978	0.516
	1,636	1.462	0.565
	1,396	1.834	0.585
	1,167	2.021	0.561
	937	2.093	0.524
	689	2.141	0.454
	457	2.186	0.382
0	2.300	0.226	
VS-400 1750 RPM	3,212	0.003	0.739
	2,898	0.601	0.838
	2,577	1.269	0.956
	2,245	1.815	1.034
	1,926	2.310	1.079
	1,620	2.585	1.051
	1,281	2.709	0.959
	957	2.770	0.844
	512	2.794	0.690
0	2.921	0.432	
VS-450 1750 RPM	4,673	0.002	1.206
	4,211	0.526	1.323
	3,740	1.377	1.544
	3,277	2.228	1.766
	2,815	2.909	1.871
	2,334	3.284	1.804
	1,874	3.393	1.662
	1,394	3.460	1.414
	651	3.526	1.056
0	3.707	0.654	

NOTE 1: Performance certified is for installation Type A, Free Inlet, Free Outlet. Power rating (BHP) does not include transmission losses. Performance ratings do not include the effects of appurtenances (accessories).

NOTE 2: Efficiency ratings are fan static and exclude bearing and/or Power Transmission Losses.

### Certified sound pressure level for fans of VS 225 - VS 450 sizes

Unit Size	Ps (in. wg)	Q (cfm)	Lw Loudness	63 Hz	125 Hz	250 Hz	500 Hz	1 kHz	2 kHz	4 kHz	8 kHz	Lw(A) dB(A)	Loudness Sones
VS-225 3450 RPM	0.003	1084	dB	91	74	74	78	76	80	81	81	87	29.0
			Sones	6.3	2.9	3.9	6.1	6.4	9.7	12.2	14.9		
	1.786	810	dB	87	74	78	79	76	74	68	70	81	19.1
			Sones	4.8	2.9	5.1	6.4	6.3	6.9	5.8	7.6		
	3.059	538	dB	87	77	80	79	72	70	62	61	79	16.2
			Sones	4.8	3.6	5.8	6.3	5.0	5.4	4.1	4.3		
3.395	280	dB	86	75	78	80	75	74	68	69	81	18.7	
		Sones	4.6	3.1	5.1	6.7	6.2	6.7	5.7	7.3			
VS-250 3450 RPM	0.013	754	dB	66	68	68	68	67	67	69	61	74	12.4
			Sones	1.0	1.9	2.7	3.2	3.8	4.5	6.0	4.3		
	0.640	580	dB	64	69	67	67	66	63	64	59	71	10.4
			Sones	0.8	2.0	2.7	3.1	3.5	3.5	4.5	4.0		
	1.047	410	dB	68	69	65	65	65	61	58	58	69	9.0
			Sones	1.2	2.0	2.4	2.7	3.2	3.2	3.1	3.6		
1.111	309	dB	76	73	66	65	65	61	56	54	69	8.9	
		Sones	2.2	2.7	2.5	2.8	3.2	3.1	2.8	2.9			
VS-315 3450 RPM	0.007	1625	dB	68	69	73	73	74	76	76	66	82	18.3
			Sones	1.2	2.1	3.7	4.5	5.8	7.7	9.1	5.9		
	0.951	1220	dB	67	70	73	72	71	70	69	65	77	14.2
			Sones	1.0	2.2	3.7	4.2	4.8	5.4	6.1	5.5		
	1.553	880	dB	70	72	72	71	69	67	62	64	74	12.4
			Sones	1.4	2.5	3.5	3.9	4.1	4.5	3.9	5.2		
1.767	782	dB	80	80	75	72	69	65	60	59	75	12.8	
		Sones	2.9	4.7	4.1	4.3	4.3	4.0	3.5	4.1			
VS-355 1750 RPM	0.014	2400	dB	72	73	78	77	77	78	85	71	88	28.0
			Sones	1.6	2.8	5.1	5.6	6.8	8.5	16.3	8.2		
	1.177	1420	dB	69	73	76	75	76	71	74	60	80	16.6
			Sones	1.2	2.7	4.5	4.9	6.4	5.5	7.8	4.2		
	2.043	1200	dB	71	73	74	73	75	67	63	58	78	13.5
			Sones	1.5	2.7	3.8	4.5	6.0	4.6	4.3	3.6		
2.164	600	dB	78	79	75	74	75	67	63	57	78	14.3	
		Sones	2.5	4.2	4.3	4.6	6.0	4.4	4.1	3.6			
VS-400 1750 RPM	0.009	3296	dB	78	78	81	82	80	79	82	79	88	28.0
			Sones	2.5	3.8	6.0	7.5	8.0	8.9	13.4	13.4		
	1.303	2636	dB	76	79	81	81	79	74	76	67	84	21.0
			Sones	2.2	4.1	5.9	7.3	7.6	6.8	9.3	6.4		
	2.674	1648	dB	78	78	79	81	78	66	64	61	82	16.8
			Sones	2.4	4.0	5.5	7.2	7.0	4.2	4.5	4.3		
2.843	988	dB	87	87	82	81	78	67	64	61	83	19.0	
		Sones	4.8	7.2	6.3	7.3	7.3	4.6	4.3	4.3			
VS-450 1750 RPM	0.001	4673	dB	82	82	88	86	95	86	81	88	96	45.0
			Sones	3.2	5.1	8.9	9.8	20.4	13.9	11.9	23.4		
	1.405	3710	dB	82	83	86	85	86	80	79	79	90	31.0
			Sones	3.3	5.7	8.0	8.8	11.7	9.4	10.6	13.3		
	2.986	2715	dB	82	81	85	84	98	78	73	69	98	40.0
			Sones	3.2	4.7	7.7	8.5	25.7	8.7	7.5	7.2		
3.457	1200	dB	83	87	85	83	101	84	71	67	101	48.0	
		Sones	3.6	7.2	7.6	8.2	32.0	12.1	6.8	6.6			

NOTE 1: The sound power level ratings shown are in decibels, referred to 10-12 watts, calculated per AMCA Standard 301. Values shown are for inlet LwA sound power levels and inlet hemispherical sone levels for installation type A: Free Inlet, Free outlet, calculated per AMCA Standard 301. The AMCA Certified Ratings Seal applies to air performance only.



# CUSTOMER TESTIMONIES

## Texas Air Products

Texas Air Products has been incredibly impressed with the quick deliveries. There are so many projects these days that require a quick response time to meet the construction cycle.

VTS is the only factory that can deliver that quickly. When our customers see the quality of the air handler and realize they can have it delivered in one to two weeks, they are just amazed. We took a sample air handler around to various engineers and contractors and everyone was very surprised at the quality compared to similar units on the market. One engineer we work with recently said:

“ THAT AIR HANDLER IS AWESOME. IT’S QUIET AND WELL BUILT. I PLAN ON SPECIFYING IT AS OFTEN AS I CAN. ”

Travis McLeod, P.E.  
Vice President

## Oberlin College Inn Remodel

Oberlin College and Conservatory, noteworthy for being the first integrated and coeducational higher education facility in the United States, recently underwent a remodel of the Campus Inn. The specified air handling manufacturer, was unable to meet the lead time to complete the remodel on time, causing major construction delays and inevitably causing the project to be put on hold.

The VTS team working with the Ohio representative, the Northrich Company went to work. The project involved 6 air handler units with energy recovery wheels and 2 makeup air handling units. The equipment was proposed to the college and the design engineers.

After close collaboration with the project management team, engineers and other trades VTS was accepted as a suitable substitute for the original design.

“ HAVING THE INDUSTRY’S FASTEST LEAD TIME, VTS WAS ABLE TO PROVIDE A QUICK AND AFFORDABLE SOLUTION TO GET OBERLIN COLLEGE’S CONSTRUCTION SCHEDULE BACK ON TIME AND BUDGET. ”

Mike Goetz  
Principal

With the submitted product not meeting the customers deadline for delivery we turned to VTS. As a result we were able to meet expectations on delivery and even had a few weeks to spare. Not only was the contractor pleased with the speedy delivery but the unit construction was impressive to say the least. The double wall construction and integral vfd's were a substantial upgrade to the specified unit and the engineer was impressed with the the considerable upgrade.

“ WE WILL BE TURNING TO VTS FOR OUR AIR HANDLING NEEDS IN THE FUTURE. ”

Robert Boozer  
Principal

# SYMBOLS AND LABELS

## Basic symbols

PROCESS			FUNCTION
Symbol	Graphic	Name	Options of functions
F		AIR FILTRATION	FILTER
V		VENTILATION	FAN
C		AIR COOLING	HYDRONIC COOLING COIL DX COOLING COIL RUN-AROUND COIL
H		AIR HEATING	HYDRONIC HEATING COIL ELECTRIC HEATER DX HEATING STEAM HEATER RUN-AROUND COIL
M		MIXING BOX	MIXING BOX
P		ENERGY RECOVERY	CROSS FLOW PLATE
R		ENERGY RECOVERY	ENERGY WHEEL

## Auxiliary symbols

Symbol	Graphic	Name
FC		FLEXIBLE CONNECTION
AD		DAMPER
FLG		FLANGES
E		EMPTY SECTION





VTS America, Inc.  
1650 Horizon Parkway  
Suite 100  
Buford, GA 30518  
United States of America  
Tel: 470-809-6811  
Fax: 470-809-6815  
e-mail: [america@vtsgroup.com](mailto:america@vtsgroup.com)

The features mentioned are subject to continuous upgrade and can change any time.  
VTS assuring continuous improvement for product and data and reserves the right to change design and specifications without notice.

[www.vtsgroup.com](http://www.vtsgroup.com)