

# AIRCONCEPTS

AIR DISTRIBUTION PRODUCTS

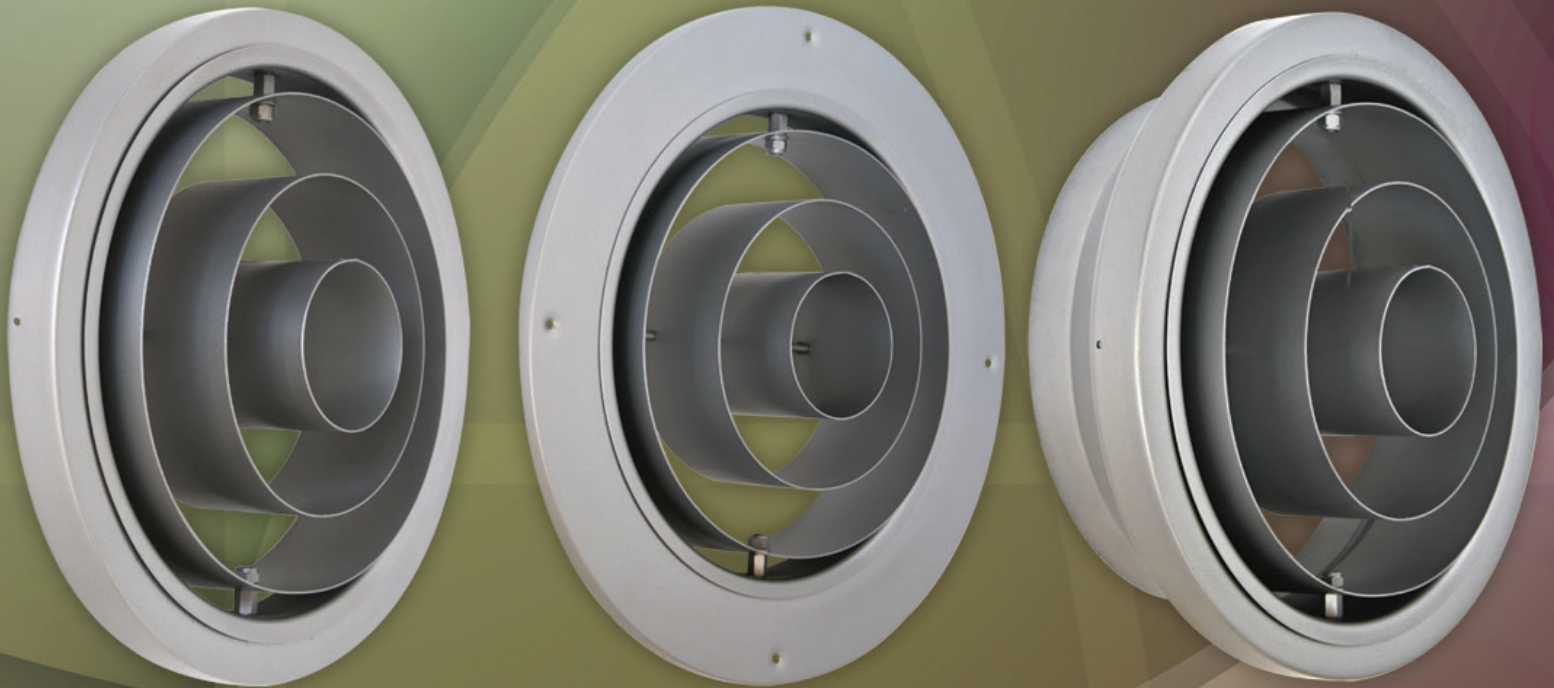

ANC-RD/RP/RR SERIES

# ANC-RD/RP/RR

**ANC-RD**  
Exposed Round Duct

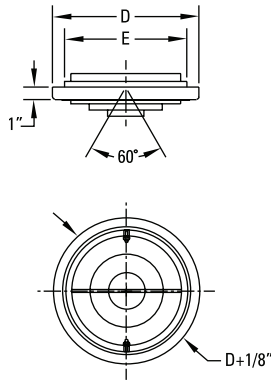

**ANC-RP**  
Wall/Ceiling Mount

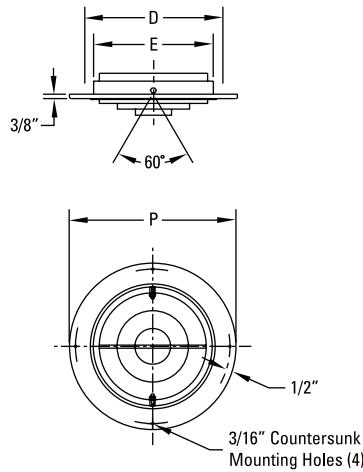

**ANC-RR**  
Exposed Round Duct

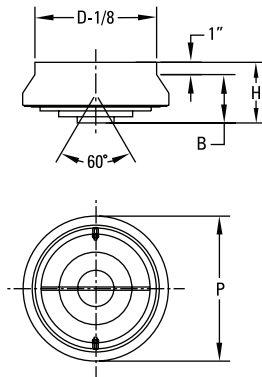

**ANC-RD Dimensions in Inches**

MODEL	E	RINGS	D
ANC-04-RD	4	3	6
ANC-05-RD	5	3	6
ANC-06-RD	6	3	8
ANC-08-RD	8	3	10
ANC-10-RD	10	3	12
ANC-12-RD	12	3	14
ANC-14-RD	14	4	16
ANC-16-RD	16	4	18
ANC-18-RD	18	4	20
ANC-20-RD	20	5	22
ANC-22-RD	22	5	24
ANC-24-RD	24	5	26

**ANC-RP Dimensions in Inches**

MODEL	E	RINGS	D	P
ANC-04-RP	4	3	6	8
ANC-06-RP	6	3	8	10
ANC-08-RP	8	3	10	12
ANC-10-RP	10	3	12	14
ANC-12-RP	12	3	14	16
ANC-14-RP	14	4	16	18
ANC-16-RP	16	4	18	20
ANC-18-RP	18	4	20	22
ANC-20-RP	20	5	22	24
ANC-22-RP	22	5	24	26
ANC-24-RP	24	5	26	28

**ANC-RR Dimensions in Inches**

MODEL	E	RINGS	D	P
ANC-04-RR	4	3	4	6
ANC-06-RR	6	3	6	8
ANC-08-RR	8	3	8	10
ANC-10-RR	10	3	10	12
ANC-12-RR	12	3	12	14
ANC-14-RR	14	4	14	16
ANC-16-RR	16	4	16	18
ANC-18-RR	18	4	18	20
ANC-20-RR	20	5	20	22
ANC-22-RR	22	5	22	24
ANC-24-RR	24	5	24	26

## Adjustability

Easy Finger Tip Adjustment  
Directional Air Pattern Control:  
±30° Degree Deflection  
360° Degree Rotation

## Construction

Standard Construction:  
Heavy Gauge Metal Construction  
Special Construction:  
Aluminum Construction  
Stainless Steel Construction

## Finishes

Standard: #52 White powder coat  
Optional standard: #00 Mill (Alum)  
#10 Clear anodized (Alum)  
#12 Anodized powder coat  
#42 Gloss black powder coat  
#43 Flat black powder coat  
#62 Grey prime powder coat  
#72 Silver metallic powder coat  
Custom colors available

MODEL	Nozzle Velocity (FPM)	573	860	1147	1433	1720	2007	2294
<b>ANC-04</b>	CFM	50	75	100	125	150	175	200
	Projection	4-8-13	6-12-16	8-13-19	10-15-21	12-16-23	13-18-25	13-19-27
	Total Pressure	0.036	0.081	0.144	0.225	0.324	0.441	0.576
	NC	<20	<20	<20	25	30	35	39
<b>ANC-04-2</b>	CFM	100	150	200	250	300	350	400
	Projection	6-11-19	9-16-23	11-19-27	14-21-30	16-23-33	18-25-36	19-27-38
	Total Pressure	0.036	0.081	0.144	0.225	0.324	0.441	0.576
	NC	<20	<20	21	28	33	38	42
<b>ANC-04-3</b>	CFM	150	225	300	375	450	525	600
	Projection	7-14-23	11-20-29	14-23-33	18-26-37	20-29-40	22-31-44	23-33-47
	Total Pressure	0.036	0.081	0.144	0.225	0.324	0.441	0.576
	NC	<20	<20	23	30	35	40	44
<b>ANC-04-4</b>	CFM	200	300	400	500	600	700	800
	Projection	8-16-27	12-23-33	16-27-38	20-30-43	23-33-47	25-36-50	27-38-54
	Total Pressure	0.036	0.081	0.144	0.225	0.324	0.441	0.576
	NC	<20	<20	24	31	36	41	45
MODEL	Nozzle Velocity (FPM)	807	1028	1248	1468	1688	1908	2128
<b>ANC-05</b>	CFM	110	140	170	200	230	260	290
	Projection	7-14-20	9-16-23	11-18-25	13-19-27	14-20-29	15-22-31	16-23-32
	Total Pressure	0.071	0.116	0.170	0.236	0.312	0.399	0.496
	NC	<20	<20	23	28	32	36	39
<b>ANC-05-2</b>	CFM	220	280	340	400	460	520	580
	Projection	10-20-28	13-23-32	16-25-35	18-27-38	20-29-41	22-31-43	23-32-46
	Total Pressure	0.071	0.116	0.170	0.236	0.312	0.399	0.496
	NC	<20	20	26	31	35	39	42
<b>ANC-05-3</b>	CFM	330	420	510	600	690	780	870
	Projection	12-24-35	16-28-39	19-30-43	22-33-47	25-35-50	27-38-53	28-40-56
	Total Pressure	0.071	0.116	0.170	0.236	0.312	0.399	0.496
	NC	<20	22	27	32	37	40	44
<b>ANC-05-4</b>	CFM	440	560	680	800	920	1040	1160
	Projection	14-28-40	18-32-45	22-35-50	26-38-54	29-41-58	31-43-61	32-46-65
	Total Pressure	0.071	0.116	0.170	0.236	0.312	0.399	0.496
	NC	<20	23	29	34	38	42	45

performance data based on ASHRAE 70-06

**Airflow CFM:** Standard air density and isothermal conditions.

**Total Pressure:** Inches of water gauge required.

**Nozzle Velocity:** Nozzle Discharge Velocity in feet per minute [fpm].

**Noise Criteria:** Noise criteria [NC] curve which is not exceeded with a Room Attenuation of 10db and based on Sound Power Level Re: 10-12 watts.

**Projection:** Projection distance [THROW] in feet from the Nozzle discharge at which the maximum velocity has been reduced to specified terminal velocity [Vt].

**Terminal Velocity:** Maximum velocity [Vt] in feet per minute at the specified distance from the outlet face [THROW] 200 fpm, 100 fpm, and 50 fpm respectively.

MODEL	Nozzle Velocity (FPM)	714	917	1121	1352	1529	1733	1937
ANC-06	CFM	140	180	220	260	300	340	380
	Projection	8-15-23	10-18-26	12-20-28	14-22-31	16-23-33	18-25-35	19-26-37
	Total Pressure	0.056	0.092	0.138	0.192	0.256	0.329	0.411
	NC	<20	<20	21	26	30	34	38
ANC-06-2	CFM	280	360	440	520	600	680	760
	Projection	11-21-32	14-26-36	17-28-40	20-31-43	23-33-47	25-35-50	26-37-53
	Total Pressure	0.056	0.092	0.138	0.192	0.256	0.329	0.411
	NC	<20	<20	24	29	33	37	41
ANC-06-3	CFM	420	540	660	780	900	1020	1140
	Projection	13-26-39	17-31-44	21-35-49	24-38-53	28-40-57	30-43-61	32-45-64
	Total Pressure	0.056	0.092	0.138	0.192	0.256	0.329	0.411
	NC	<20	20	26	31	35	39	42
ANC-06-4	CFM	560	720	880	1040	1200	1360	1520
	Projection	15-30-45	19-36-51	24-40-57	28-43-61	32-47-66	35-50-70	37-53-74
	Total Pressure	0.056	0.092	0.138	0.192	0.256	0.329	0.411
	NC	<20	21	27	32	36	40	44
MODEL	Nozzle Velocity (FPM)	573	717	860	1003	1147	1290	1433
ANC-08	CFM	200	250	300	350	400	450	500
	Projection	8-16-27	10-20-30	12-23-33	14-25-36	16-27-38	18-29-40	20-30-43
	Total Pressure	0.036	0.056	0.081	0.110	0.144	0.182	0.225
	NC	<20	<20	<20	20	24	28	31
ANC-08-2	CFM	400	500	600	700	800	900	1000
	Projection	11-23-38	14-29-43	17-33-47	20-36-50	23-38-54	26-40-57	29-43-60
	Total Pressure	0.036	0.056	0.081	0.110	0.144	0.182	0.225
	NC	<20	<20	<20	23	27	31	34
ANC-08-3	CFM	600	750	900	1050	1200	1350	1500
	Projection	14-28-47	18-35-52	21-40-57	25-44-62	28-47-66	32-49-70	35-52-74
	Total Pressure	0.036	0.056	0.081	0.110	0.144	0.182	0.225
	NC	<20	<20	20	25	29	32	36
ANC-08-4	CFM	800	1000	1200	1400	1600	1800	2000
	Projection	16-32-54	20-40-60	24-47-66	28-50-71	32-54-76	36-57-81	40-60-85
	Total Pressure	0.036	0.056	0.081	0.110	0.144	0.182	0.225
	NC	<20	<20	21	26	30	34	37

performance data based on ASHRAE 70-06

**Airflow CFM:** Standard air density and isothermal conditions.

**Noise Criteria:** Noise criteria [NC] curve which is not exceeded with a Room Attenuation of 10db and based on Sound Power Level Re: 10-12 watts.

**Total Pressure:** Inches of water gauge required.

**Projection:** Projection distance [THROW] in feet from the Nozzle discharge at which the maximum velocity has been reduced to specified terminal velocity [Vt].

**Nozzle Velocity:** Nozzle Discharge Velocity in feet per minute [fpm].

**Terminal Velocity:** Maximum velocity [Vt] in feet per minute at the specified distance from the outlet face [THROW] 200 fpm, 100 fpm, and 50 fpm respectively.



MODEL	Nozzle Velocity (FPM)	550	734	917	1101	1284	1468	1651
<b>ANC-10</b>	CFM	300	400	500	600	700	800	900
	Projection	10-19-33	13-26-38	16-30-43	19-33-47	23-36-50	26-38-54	29-40-57
	Total Pressure	0.033	0.059	0.092	0.133	0.181	0.236	0.299
	NC	<20	<20	<20	25	30	34	37
<b>ANC-10-2</b>	CFM	600	800	1000	1200	1400	1600	1800
	Projection	14-27-47	18-37-54	23-43-60	27-47-66	32-50-71	37-54-76	40-57-81
	Total Pressure	0.033	0.059	0.092	0.133	0.181	0.236	0.299
	NC	<20	<20	22	28	32	37	40
<b>ANC-10-3</b>	CFM	900	1200	1500	1800	2100	2400	2700
	Projection	17-34-57	22-45-66	28-52-74	34-57-81	39-62-87	45-66-93	49-70-99
	Total Pressure	0.033	0.059	0.092	0.133	0.181	0.236	0.299
	NC	<20	<20	24	30	34	38	42
<b>ANC-10-4</b>	CFM	1200	1600	2000	2400	2800	3200	3600
	Projection	19-39-66	26-52-76	32-60-85	39-66-93	45-71-101	52-76-108	57-81-114
	Total Pressure	0.033	0.059	0.092	0.133	0.181	0.236	0.299
	NC	<20	20	25	31	35	40	43
MODEL	Nozzle Velocity (FPM)	573	765	956	1147	1338	1529	1720
<b>ANC-12</b>	CFM	450	600	750	900	1050	1200	1350
	Projection	12-24-40	16-32-47	20-37-52	24-40-57	28-44-62	32-47-66	35-49-70
	Total Pressure	0.036	0.064	0.100	0.144	0.196	0.256	0.324
	NC	<20	<20	22	28	32	39	40
<b>ANC-12-2</b>	CFM	900	1200	1500	1800	2100	2400	2700
	Projection	17-34-57	23-46-66	29-52-74	34-57-81	40-62-87	46-66-93	49-70-99
	Total Pressure	0.036	0.064	0.100	0.144	0.196	0.256	0.324
	NC	<20	<20	25	31	35	39	43
<b>ANC-12-3</b>	CFM	1350	1800	2250	2700	3150	3600	4050
	Projection	21-42-70	28-56-81	35-64-90	42-70-99	49-76-107	56-81-114	61-86-121
	Total Pressure	0.036	0.064	0.100	0.144	0.196	0.256	0.324
	NC	<20	21	27	32	37	41	45
<b>ANC-12-4</b>	CFM	1800	2400	3000	3600	4200	4800	5400
	Projection	24-49-81	32-65-93	40-74-104	49-81-114	57-87-123	65-93-132	70-99-140
	Total Pressure	0.036	0.064	0.100	0.144	0.196	0.256	0.324
	NC	<20	22	28	34	38	42	46

performance data based on ASHRAE 70-06

**Airflow CFM:** Standard air density and isothermal conditions.

**Noise Criteria:** Noise criteria [NC] curve which is not exceeded with a Room Attenuation of 10db and based on Sound Power Level Re: 10-12 watts.

**Total Pressure:** Inches of water gauge required.

**Projection:** Projection distance [THROW] in feet from the Nozzle discharge at which the maximum velocity has been reduced to specified terminal velocity [Vt].

**Nozzle Velocity:** Nozzle Discharge Velocity in feet per minute [fpm].

**Terminal Velocity:** Maximum velocity [Vt] in feet per minute at the specified distance from the outlet face [THROW] 200 fpm, 100 fpm, and 50 fpm respectively.

MODEL	Nozzle Velocity (FPM)	562	749	936	1123	1311	1498	1685
ANC-14	CFM	600	800	1000	1200	1400	1600	1800
	Projection	14-28-47	18-37-54	23-43-60	28-47-66	32-50-71	37-54-76	40-57-81
	Total Pressure	0.035	0.061	0.096	0.138	0.188	0.246	0.311
	NC	<20	<20	23	28	33	37	41
ANC-14-2	CFM	1200	1600	2000	2400	2800	3200	3600
	Projection	20-39-66	26-52-76	33-60-85	39-66-93	46-71-101	52-76-108	57-81-114
	Total Pressure	0.035	0.061	0.096	0.138	0.188	0.246	0.311
	NC	<20	20	26	31	36	40	44
ANC-14-3	CFM	1800	2400	3000	3600	4200	4800	5400
	Projection	24-48-81	32-64-93	40-74-104	48-81-114	56-87-123	64-93-132	70-99-140
	Total Pressure	0.035	0.061	0.096	0.138	0.188	0.246	0.311
	NC	<20	22	28	33	38	42	45
ANC-14-4	CFM	2400	3200	4000	4800	5600	6400	7200
	Projection	28-55-93	37-74-108	46-85-120	55-93-132	65-101-143	74-108-152	81-114-162
	Total Pressure	0.035	0.061	0.096	0.138	0.188	0.246	0.311
	NC	<20	23	29	34	39	43	47
MODEL	Nozzle Velocity (FPM)	538	717	896	1075	1245	1433	1613
ANC-16	CFM	750	1000	1250	1500	1750	2000	2250
	Projection	15-30-52	20-40-60	25-48-67	30-52-74	35-56-80	40-60-85	45-64-90
	Total Pressure	0.032	0.056	0.088	0.127	0.172	0.225	0.285
	NC	<20	<20	23	28	33	37	40
ANC-16-2	CFM	1500	2000	2500	3000	3500	4000	4500
	Projection	21-43-74	29-57-85	36-67-95	43-74-104	50-80-113	57-85-120	64-90-128
	Total Pressure	0.032	0.056	0.088	0.127	0.172	0.225	0.285
	NC	<20	20	26	31	36	40	43
ANC-16-3	CFM	2250	3000	3750	4500	5250	6000	6750
	Projection	26-53-90	35-70-104	44-82-117	53-90-128	61-98-138	70-104-148	78-111-157
	Total Pressure	0.032	0.056	0.088	0.127	0.172	0.225	0.285
	NC	<20	22	27	33	38	42	45
ANC-16-4	CFM	3000	4000	5000	6000	7000	8000	9000
	Projection	30-61-104	40-81-120	51-95-135	61-104-148	71-113-159	81-120-170	90-128-181
	Total Pressure	0.032	0.056	0.088	0.127	0.172	0.225	0.285
	NC	<20	23	29	34	39	43	46

performance data based on ASHRAE 70-06

**Airflow CFM:** Standard air density and isothermal conditions.

**Noise Criteria:** Noise criteria [NC] curve which is not exceeded with a Room Attenuation of 10db and based on Sound Power Level Re: 10-12 watts.

**Total Pressure:** Inches of water gauge required.

**Projection:** Projection distance [THROW] in feet from the Nozzle discharge at which the maximum velocity has been reduced to specified terminal velocity [Vt].

**Nozzle Velocity:** Nozzle Discharge Velocity in feet per minute [fpm].

**Terminal Velocity:** Maximum velocity [Vt] in feet per minute at the specified distance from the outlet face [THROW] 200 fpm, 100 fpm, and 50 fpm respectively.

MODEL	Nozzle Velocity (FPM)	566	736	906	1076	1246	1416	1586
<b>ANC-18</b>	CFM	1000	1300	1600	1900	2200	2500	2800
	Projection	18-36-60	23-47-69	29-54-76	34-59-83	40-63-89	45-67-95	50-71-101
	Total Pressure	0.035	0.059	0.090	0.127	0.170	0.219	0.275
	NC	<20	<20	<20	29	34	38	41
<b>ANC-18-2</b>	CFM	2000	2600	3200	3800	4400	5000	5600
	Projection	25-51-85	33-66-97	41-76-108	48-83-117	56-89-126	64-95-135	71-101-143
	Total Pressure	0.035	0.059	0.090	0.127	0.170	0.219	0.275
	NC	<20	22	27	32	34	41	44
<b>ANC-18-3</b>	CFM	3000	3900	4800	5700	6600	7500	8400
	Projection	31-62-104	40-81-119	50-93-132	59-102-144	68-109-155	78-117-165	87-123-175
	Total Pressure	0.035	0.059	0.090	0.127	0.170	0.219	0.275
	NC	<20	24	29	34	38	42	46
<b>ANC-18-4</b>	CFM	4000	5200	6400	7600	8800	10000	11200
	Projection	36-72-120	47-93-137	57-108-152	68-117-166	79-126-179	90-135-190	101-143-202
	Total Pressure	0.035	0.059	0.090	0.127	0.170	0.219	0.275
	NC	<20	25	30	35	40	44	47
<b>MODEL</b>	<b>Nozzle Velocity (FPM)</b>	<b>458</b>	<b>596</b>	<b>733</b>	<b>871</b>	<b>1008</b>	<b>1146</b>	<b>1283</b>
<b>ANC-20</b>	CFM	1000	1300	1600	1900	2200	2500	2800
	Projection	16-33-60	21-42-69	26-52-76	31-59-83	36-63-89	41-67-95	46-71-101
	Total Pressure	0.025	0.042	0.064	0.090	0.120	0.160	0.200
	NC	<20	<20	<20	23	26	28	31
<b>MODEL</b>	<b>Nozzle Velocity (FPM)</b>	<b>454</b>	<b>606</b>	<b>758</b>	<b>909</b>	<b>1061</b>	<b>1212</b>	<b>1364</b>
<b>ANC-22</b>	CFM	1200	1600	2000	2400	2800	3200	3600
	Projection	17-34-66	23-46-76	29-57-85	34-66-93	40-71-101	46-76-108	51-81-114
	Total Pressure	0.025	0.042	0.068	0.096	0.130	0.170	0.220
	NC	<20	<20	21	25	30	34	39
<b>MODEL</b>	<b>Nozzle Velocity (FPM)</b>	<b>477</b>	<b>636</b>	<b>796</b>	<b>955</b>	<b>1114</b>	<b>1273</b>	<b>1432</b>
<b>ANC-24</b>	CFM	1500	2000	2500	3000	3500	4000	4500
	Projection	20-40-74	27-53-85	33-67-95	40-74-104	47-80-113	53-85-120	60-90-128
	Total Pressure	0.028	0.046	0.070	0.110	0.140	0.190	0.230
	NC	<20	<20	22	27	32	37	42

performance data based on ASHRAE 70-06

**Airflow CFM:** Standard air density and isothermal conditions.

**Noise Criteria:** Noise criteria [NC] curve which is not exceeded with a Room Attenuation of 10db and based on Sound Power Level Re: 10-12 watts.

**Total Pressure:** Inches of water gauge required.

**Projection:** Projection distance [THROW] in feet from the Nozzle discharge at which the maximum velocity has been reduced to specified terminal velocity [Vt].

**Nozzle Velocity:** Nozzle Discharge Velocity in feet per minute [fpm].

**Terminal Velocity:** Maximum velocity [Vt] in feet per minute at the specified distance from the outlet face [THROW] 200 fpm, 100 fpm, and 50 fpm respectively.







