

Packaged Air Cooled Modular Chiller Water Cooled, Heat Pump, Heat Recovery and Simultaneous Heating and Cooling Heat Pump

Model UCA 20, 30, 50 & 70

Installation, Operation & Maintenance Manual



CLIMA  **COOL**®
THE ULTIMATE CHILLER SOLUTION®



Table of Contents

Introduction	1	Startup	30-31
Pre-Installation	2	Superheat & Subcooling Flow Chart.....	32
Physical Data.....	3-5	Startup and Warranty Form	33
Dimensional Data and Drawings	6-8	Operation and Maintenance	34
Rigging and Lifting Procedures	9	Condenser Fans	35
Mounting Rail and Vibration Isolation	10	Heat Exchangers	36
Recommended Service Clearances.....	11	Cleaning Arrangement	37
Model Key	12	Compressor Information	38
Unit Installation	13-14	Refrigeration Circuit Diagram	39-41
Electrical Connection.....	15	Head Pressure Control Valve Operation (LAC).....	42
Wiring Diagram-Voltage/Phase Monitor	16	Refrigeration Systems Re-Processing and Charging	43
Water Piping.....	17-18	Engineering Guide Specifications	44-45
Water Piping Configurations	19	Options & Accessories	46
Hydronic Refrigeration	20	Stainless Steel Strainer Option	47-51
Part Load Performance Advantage	21	WYE Strainers	52-53
Filling the Water System.....	22	Basket Strainers	54-55
Water Treatment	23	Electrical Data.....	56-57
Water Temperature Requirements.....	24	Power Distribution Drawing.....	58
Evaporator Water Pressure Drop Charts	25-26	Wiring Diagrams.....	59-87
Operational Limitations	27	Troubleshooting Guide	88
Pre-Startup	28	Warranty	89
Pre-Startup Check List.....	29		

Introduction

General Description

ClimaCool's Air Cooled Packaged Modular Chiller, Model UCA, are available in 20, 30, 50 and 70 tons and can be configured to provide project turndown and capacity requirements from 20 to 420 tons. By simply adding modules, the UCA can satisfy future incremental growth needs. This model is a quiet, serviceable and extremely efficient system that will provide years of reliable operation.

Safety

Throughout this manual warning, danger, caution and attention notices appear. Read these items carefully before attempting any installation, service or troubleshooting of the equipment. All labels on unit access panels must be observed.

WARNING: Indicates potentially hazardous situation which, if not avoided, could result in death or serious injury.

DANGER: Indicates an immediate hazardous situation which, if not avoided, will result in death or serious injury.

CAUTION: Indicates a potentially hazardous situation or an unsafe practice which, if not avoided, could result in minor or moderate injury or product or property damage.

ATTENTION: Notification of installed, operation or maintenance information which is important, but not hazard related.

ATTENTION	
To avoid the release of refrigerant into the atmosphere, the refrigerant circuit of this unit must be serviced only by technicians who meet local, state and federal proficiency requirements.	
All refrigerant discharged from this unit must be recovered WITHOUT EXCEPTION. Technicians must follow industry accepted guidelines and all local, state and federal statutes for the recovery and disposal of refrigerants.	
If a compressor is removed from the unit, system refrigerant circuit oil will remain in the compressor. To avoid leakage of compressor oil, the refrigerant lines of the compressor must be sealed after it is removed.	

WARNING/AVERTISSEMENT	
	
WATER AND REFRIGERANT SYSTEMS UNDER PRESSURE	EAU ET FRIGORIGÈNE EQUIPEMENTS SOUS PRESSION
<ul style="list-style-type: none"> Isolate/Lockout source and relieve pressure BEFORE servicing equipment. Failure to relieve pressure may result in property damage, serious bodily injury or death! 	<ul style="list-style-type: none"> Isoler la source / de verrouillage et de soulager la pression avant entretien de l'équipement. Le défaut de soulager la pression peut entraîner des dommages matériels, des blessures corporelles graves ou la mort!

ATTENTION	
Confirm all panels and electrical covers are properly installed/sealed, including the condenser fan motor cover.	



WARNING/AVERTISSEMENT	
Very Hot Water!	L'eau Très Chaude!

ATTENTION	
Do not defeat, cap, add piping to the outlet of the valve or attempt to change the relief setting.	

CAUTION/ATTENTION	
Excessive Chlorine, undissolved solids and other improper water conditions WILL DAMAGE the internal heat exchanger & WILL VOID YOUR WARRANTY!	Chlore excessive, solides non dissous et les autres impropres conditions de l'eau, ENDOMMAGERA l'échangeur de chaleur interne et ANNULERA VOTRE GARANTIE!

CAUTION/ATTENTION	
Use only copper conductors for field installed wiring. Unit terminals are not designed to accept other types of conductors.	Utilisez uniquement des conducteurs en cuivre pour le câblage. Bornes de l'unité ne sont pas conçues pour accepter d'autres types de conducteurs.

CAUTION/ATTENTION	
Single wall heat exchanger, not suitable for potable water connection.	Single paroi échangeur, non approprié pour le raccordement d'eau potable.

WARNING/AVERTISSEMENT	
Disconnect power supply (ies) before servicing. Refer servicing to qualified service personnel. Electric shock hazard. May result in injury or death!	 Debrancher avant d'entreprendre le dépannage de l'appareil. Consulter un réparateur qualifié pour le dépannage. Risque de choc électrique. Résultat de mal dans dommages ou la mort!
CAUTION/ATTENTION	
Unit to be serviced by qualified personnel only. Refrigerant system under pressure. Relieve pressure before using torch. Recover refrigerant and store or dispose of properly.	 Conifer la maintenance à un technicien qualifié. Le système frigorifique sous pression. Décompresser avant d'exposer à la flamme. Récupérer le frigorigène et le stocker ou le détruire correctement.

CAUTION/ATTENTION	
3 PHASE SCROLL COMPRESSOR UNITS	UNITÉ DE COMPRESSEUR SCROLL 3-PHASE
If this unit uses a 3 Phase Scroll Compressor, the following instructions MUST BE followed: <ul style="list-style-type: none"> Unit power supply MUST BE wired in the proper sequence to avoid damage to the 3 Phase Scroll Compressor; Scroll Compressors with INCORRECT rotation show the following characteristics: <ul style="list-style-type: none"> High sound level; High suction pressure and low discharge pressure; Low current draw. If any of the three above characteristics exist, swap two of the three supply wires at the disconnect and recheck compressor for incorrect rotation. 	Si cet appareil utilise compresseur scroll 3-Phase, les instructions suivantes doivent être suivies: <ul style="list-style-type: none"> L'alimentation de l'appareil doit être monté dans l'ordre correct pour éviter endommager le compresseur scroll 3-Phase Compresseurs scroll avec rotation incorrecte montrent les caractéristiques suivantes: <ul style="list-style-type: none"> Haut niveau de son; Pression d'aspiration élevée et une faible pression de décharge; Faible ampérage Si l'un des trois éléments mentionnés ci-dessus sont remplies, échanger deux des trois lignes électriques alimen tant la interrupteur de sécurité et vérifier la rotation du compresseur.

Pre-Installation

Inspection

Upon receipt of equipment, carefully check the shipment against the bill of lading and inspect each chiller for any damage incurred during shipment. Thoroughly check for any visible damage of control panels, electrical and/or refrigeration components or broken copper lines. Be sure the nameplate voltage agrees with the site voltage. The carrier must make proper notation of any damages or shortages on all copies of the bill of lading and complete a common carrier inspection report prior to your final acceptance of the shipment. **Note:** It is the responsibility of the purchaser to file all necessary claims with the carrier. In addition, please notify the ClimaCool Customer Service Department at 405-815-3000 or customerservice@climacoolcorp.com of all damage immediately.

Storage

Installation and storage of Packaged Air Cooled chillers, in locations with ambient temperatures below 40°F, will require a suitable antifreeze solution.

Handling of Modules

Carefully remove the module's packaging. The chiller's steel base cutouts provide maneuverability by forklift or pallet jack into its final position (see Rigging and Lifting Procedures Figures 7, 8 and 9 on page 9). Verify that all header grooved couplings, groove by groove 6" nipples and mounting hardware kits are on site prior to connecting the modules.

Rigging and Lifting

Each module should be lifted by using a fork lift. If it is necessary to utilize a crane for rigging or lifting each module shall be lifted by using lifting straps and spreader bars using rigging points identified in the Rigging and Lifting Procedures on page 9.

Warranty

To ensure proper equipment longevity, design performance and reliability, all ClimaCool chillers must be installed, operated and maintained in accordance with ClimaCool IO&M manuals. Water quality is of the utmost importance for the proper care and maintenance of your modular chiller system and regular treatment of the water will increase longevity of your system. **Failure to provide adequate filtration or treatment of evaporator water will void the ClimaCool module's warranty.** A factory authorized technician is required to perform the startup of your ClimaCool chiller. Please contact the ClimaCool Service Department at 405-815-3000 or at technicalsupport@climacoolcorp.com to schedule. **There is a minimum of (three) 3 weeks notice required to schedule your factory startup.**

Physical Data

Model UCA	Cooling Only		Heat Pump		SHC ¹	
	20	30	20	30	20	30
Capacity (Tons) ²	18.4	27.5	17.9	26.7	17.9	26.7
EER	10.3	10.3	9.97	9.97	9.97	9.97
Refrigerant Circuits (quantity)	2	2	2	2	2	2
Compressor Type	scroll	scroll	scroll	scroll	scroll	scroll
Compressor Quantity	2	2	2	2	2	2
Compressor Nominal Hp (per circuit)	10	15	10	15	10	15
Refrigerant Charge R-410A (lbs)	50	56	50	54	50	54
Module Operating Weight w/Water (lbs) ³	2,250	2,410	2,250	2,410	3,115	3,275
Module Shipping Weight (lbs) ⁴	2,035	2,195	2,035	2,195	2,735	2,895
Condenser Fans	20	30	20	30	20	30
Motor Type	T.E.	T.E.	T.E.	T.E.	T.E.	T.E.
HP	2.0	2.0	2.0	2.0	2.0	2.0
Quantity	1	2	1	2	1	2
Fan Type	Axial	Axial	Axial	Axial	Axial	Axial
Diameter	31.5"	31.5"	31.5"	31.5"	31.5"	31.5"
Airflow (cfm per circuit)	6000	9,800	6000	9,800	6000	9,800
RPM	1,100	1,100	1,100	1,100	1,100	1,100
Maximum Design Working Pressure - refrigerant (PSI)	650	650	650	650	650	650
Condenser Coils	20	30	20	30	20	30
Fin Material	Aluminum	Aluminum	Aluminum	Aluminum	Aluminum	Aluminum
Tube Material	Copper	Copper	Copper	Copper	Copper	Copper
Dimensions (Quantity)	22" x 78" (4)	22" x 78" (4)	22" x 78" (4)	22" x 78" (4)	22" x 78" (4)	22" x 78" (4)
Rows Deep	3	4	3	4	3	4
Fins Per Inch	12	12	12	12	12	12
Evaporator	20	30	20	30	20	30
Heat Exchanger (Type)	Brazed Plate	Brazed Plate	Brazed Plate	Brazed Plate	Brazed Plate	Brazed Plate
Independent Refrigerant Circuits (quantity)	2	2	2	2	2	2
Water Storage Volume HX Only (gals.)	2.6	2.6	2.6	2.6	2.6	2.6
Water Storage Volume HX Plus 6" Main Headers (gals)	39.6	39.6	39.6	39.6	76.6	76.6
Maximum Design Working Pressure - Water Side (PSI)	300	300	300	300	300	300
Header Water Connections - Inlet/Outlet (inches) ⁵	6"	6"	6"	6"	6"	6"

Notes:

1. SHC - Simultaneous Heating and Cooling Heat Pump.
2. Unit tonnage ARI rating conditions: 44°F leaving chilled water temperature, 95°F entering condenser air temperature, flow rate is 2.4 GPM per ton through the evaporator with a .0001 fouling factor.
3. Module operational weight includes water, compressor oil, and refrigerant charge. Multiply times the number of modules for a total system operational weight.
4. Unit shipping weight includes refrigerant charge, compressor oil and packaging; based on transportation.
5. Main header water/fluid connections are ASME, 6" scheduled 40 pipe with grooved couplings, 300 psig maximum working pressure.
6. Each refrigerant circuit is capable of providing reliable operation down to 20°F ambient with proper freeze protection.

Physical Data

Model UCA	Cooling Only		Heat Pump		SHC	
	50	70	50	70	50	70
Capacity (Tons) ²	44.0	62.7	41.4	59.0	41.4	59.0
Efficiency (EER) ²	10.5	10.1	9.88	9.47	9.88	9.47
Refrigerant Circuits (quantity)	2.0	2.0	2.0	2.0	2.0	2.0
Compressor Type	Scroll	Scroll	Scroll	Scroll	Scroll	Scroll
Compressor Quantity	2	2	2	2	2	2
Compressor Nominal Hp (per circuit)	25	35	25	35	25	35
Refrigerant Charge R-410A (lbs) (circuit 1/circuite2)	114	124	110	120	110	120
Module Operating Weight w/Water (lbs) ³	4,101	4,275	4,101	4,275	4,706	4,880
Module Shipping Weight (lbs) ⁴	3,855	4,005	3,855	4,005	4,255	4,405
Condenser Fans	50	70	50	70	50	70
Motor Type	T.E.	T.E.	T.E.	T.E.	T.E.	T.E.
HP	1.5	1.5	1.5	1.5	1.5	1.5
Quantity	4	4	4	4	4	4
Fan Type	Axial	Axial	Axial	Axial	Axial	Axial
Diameter	31.5	31.5	31.5	31.5	31.5	31.5
Airflow (cfm per circuit)	7,000	10,500	7,000	10,500	7,000	10,500
Max RPM	1,100	1,100	1,100	1,100	1,100	1,100
Maximum Design Working Pressure - refrigerant (PSI)	650	650	650	650	650	650
Condenser Coils	50	70	50	70	50	70
Fin Material	Aluminum	Aluminum	Aluminum	Aluminum	Aluminum	Aluminum
Tube Material	Copper	Copper	Copper	Copper	Copper	Copper
Dimensions (Quantity)	22" x 78" (8)	22" x 78" (8)	22" x 78" (8)	22" x 78" (8)	22" x 78" (8)	22" x 78" (8)
Rows Deep	4	4	4	4	4	4
Fins Per Inch	12	12	12	12	12	12
Evaporator	50	70	50	70	50	70
Heat Exchanger (Type)	Brazed Plate	Brazed Plate	Brazed Plate	Brazed Plate	Brazed Plate	Brazed Plate
Independent Refrigerant Circuits (quantity)	2	2	2	2	2	2
Water Storage Volume HX Only (gals.)	4.9	7.7	4.9	7.7	4.9	7.7
Water Storage Volume HX Plus 6" Main Headers (gals)	43.5	48.4	43.5	48.4	43.5	48.4
Maximum Design Working Pressure - Water Side (PSI)	300	300	300	300	300	300
Header Water Connections - Inlet/Outlet (inches) ²	6"	6"	6"	6"	6"	6"

Notes:

1. SHC - Simultaneous Heating and Cooling Heat Pump
2. Unit tonnage and efficiency at AHRI rating conditions: 44°F leaving chilled water temperature, 95°F entering condenser air temperature, flow rate is 2.4 GPM per ton through the evaporator with a .0001 fouling factor.
3. Module operational weight includes water, compressor oil, and refrigerant charge. Multiply times the number of modules for a total system operational weight.
4. Unit shipping weight includes refrigerant charge, compressor oil and packaging; based on transportation.
5. Main header water/fluid connections are ASME, 6" scheduled 40 pipe with grooved couplings, 300 psig manimum working pressure.

Physical Data

	Free Cooling	
Fans	30	70
Motor Type	T.E.	T.E.
HP	2.0	2.0
Quantity	2	4
Fan Type	Axial	Axial
Diameter	31.5	31.5
Airflow (cfm per circuit)	20,000	40,000
RPM	1,100	1,100
Free Cooling Coils	30	70
Fin Material	Aluminum	Aluminum
Tube Material	Copper	Copper
Dimensions (Quantity)	20" x 78" (4)	20" x 78" (8)
Rows Deep	6	6
Fins Per Inch	8	8
Miscellaneous Information	30	70
Maximum Design Working Pressure - Water Side (PSI)	300	300
Header Water Connections - Inlet/Outlet (inches)	6"	6"
Module Operating Weight ¹	2,000	4,000
Module Shipping Weight ²	1,590	3,180

Notes:

1. Module operational weight includes water. Multiply times the number of modules for a total system operational weight.
2. Unit shipping weight includes packaging; based on transportation.

Dimensional Data and Drawings

Figure 1 - Cooling Only, UCA 020 & 030

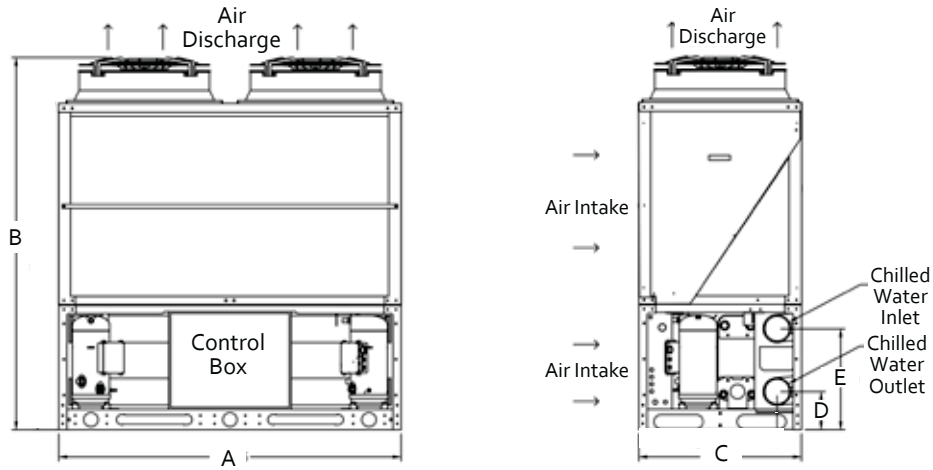

Model UCA	Voltage	A Unit Width (in.)	B Unit Height (in.)	C Unit Depth (in.)	D Header Location (in.)	E Header Location (in.)	Header Connection (in.)
020	208/230/460/575/3/60	83 3/4	92	39 3/4	9 3/10	24 7/10	6
030	208/230/460/575/3/60	83 3/4	92	39 3/4	9 3/10	24 7/10	6

Figure 2 - Cooling Only, UCA 050 & 070

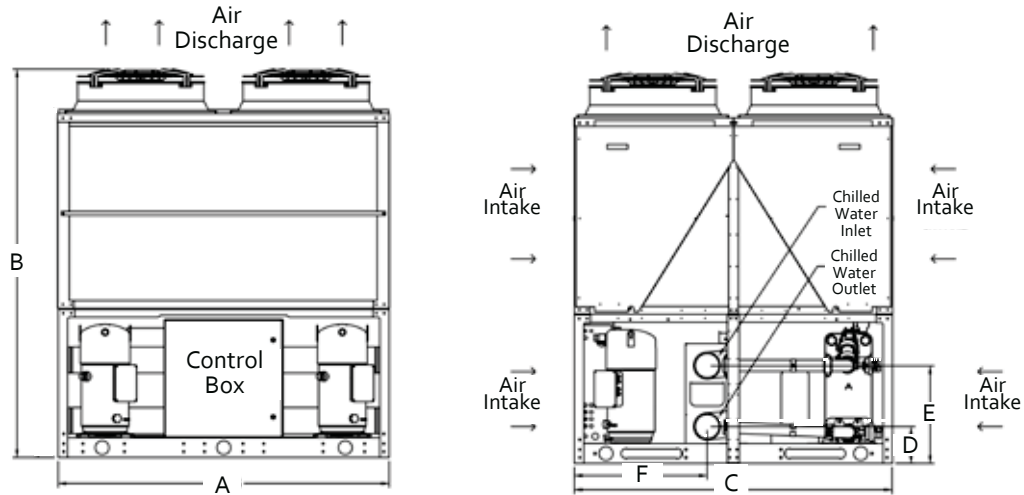

Model UCA ¹	Voltage	A Unit Width (in.)	B Unit Height (in.)	C Unit Depth (in.)	D Header Location (in.)	E Header Location (in.)	F Header Location (in.)	Header Connection (in.)
050	208/230/460/575/3/60	83 3/4	99 1/8	80 1/2	9 3/10	24 7/10	33 4/5	6
070	208/230/460/575/3/60	83 3/4	99 1/8	80 1/2	9 3/10	24 7/10	33 4/5	6

Note:

1. The model UCA 050 and 070 cannot be coupled back-to-back.

Dimensional Data and Drawings

Figure 3 - Simultaneous Heating & Cooling 020 & 030

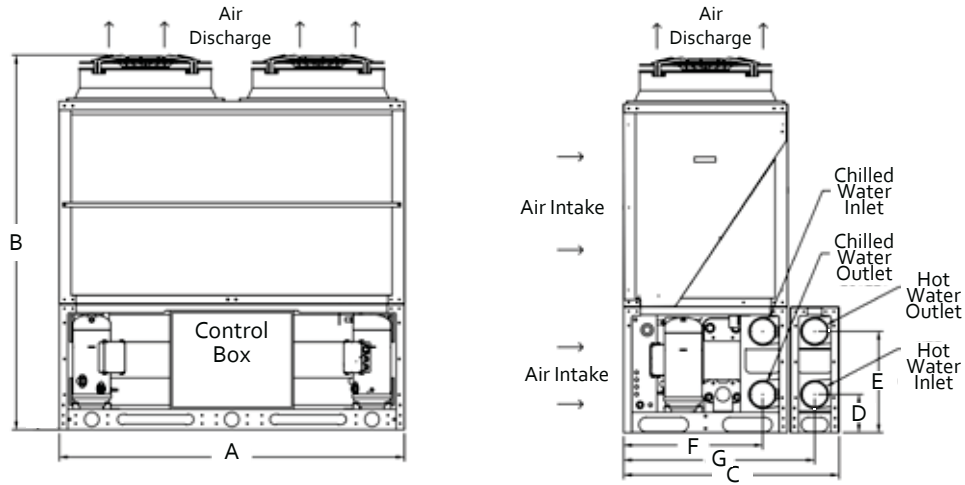

Model UCA ¹	Voltage	A Unit Width (in.)	B Unit Height (in.)	C Unit Depth (in.)	D Header Location (in.)	E Header Location (in.)	F Header Location (in.)	G Header Location (in.)	Header Connection (in.)
020 SHC	208/230/460/575/3/60	83 ¾	92	52 ½	9 ¾	24 7/10	33 4/5	46 2/5	6
030 SHC	208/230/460/575/3/60	83 ¾	92	52 ½	9 ¾	24 7/10	33 4/5	46 2/5	6

Figure 4 - Simultaneous Heating & Cooling 050 & 070

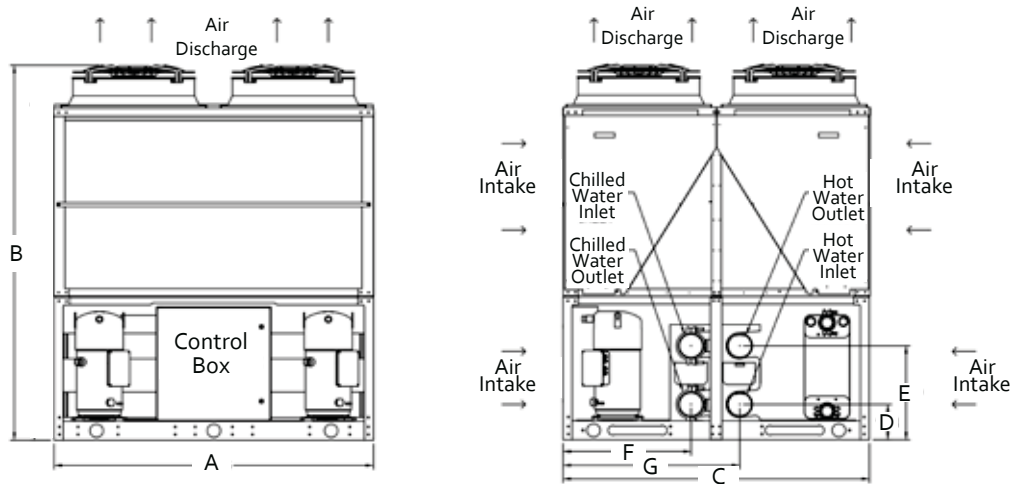

Model UCA ¹	Voltage	A Unit Width (in.)	B Unit Height (in.)	C Unit Depth (in.)	D Header Location (in.)	E Header Location (in.)	F Header Location (in.)	G Header Location (in.)	Header Connection (in.)
050 SHC	208/230/460/575/3/60	83 ¾	99 1/8	80 ½	9 ¾	24 7/10	33 4/5	46 2/5	6
070 SHC	208/230/460/575/3/60	83 ¾	99 1/8	80 ½	9 ¾	24 7/10	33 4/5	46 2/5	6

Notes:

1. All SHC models cannot be coupled back-to-back.

Dimensional Data and Drawings

Figure 5 - Free Cooling, UCF 030

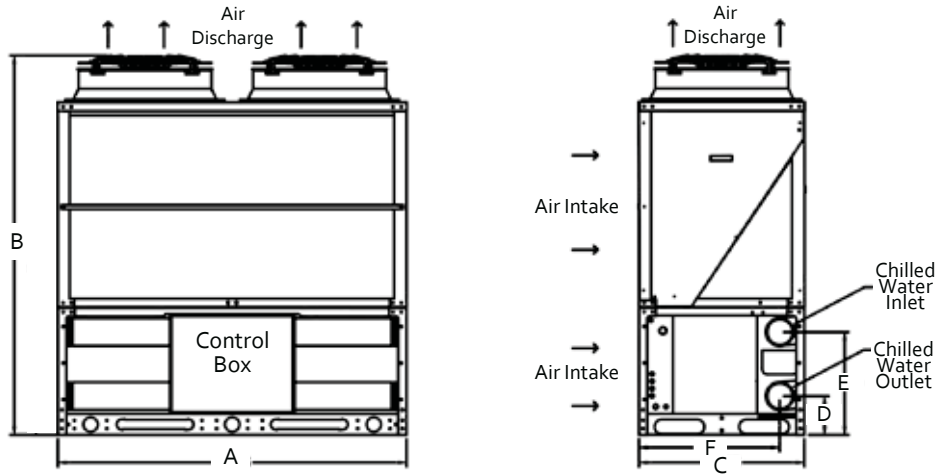

Model UCF	Voltage	A Unit Width (in.)	B Unit Height (in.)	C Unit Depth (in.)	D Header Location (in.)	E Header Location (in.)	F Header Location (in.)	Header Connection (in.)
030	208/230/460/575/3/60	83 3/4	92	39 3/4	9 3/10	24 7/10	33 4/5	6

Figure 6 - Free Cooling, UCF 070

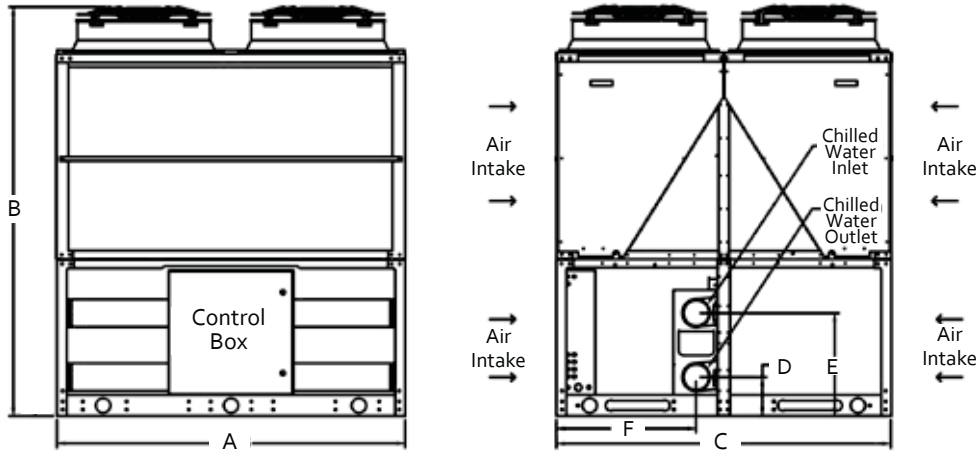

Model UCF ¹	Voltage	A Unit Width (in.)	B Unit Height (in.)	C Unit Depth (in.)	D Header Location (in.)	E Header Location (in.)	F Header Location (in.)	Header Connection (in.)
070	208/230/460/575/3/60	83 3/4	99 1/8	80 1/2	9 3/10	24 7/10	33 4/5	6

Note:
1. The model UCF 070 cannot be coupled back-to-back.

Rigging and Lifting Procedures

Rigging

Each module should be lifted by using lift straps threaded through the steel base cutouts and a spreader bar.

Note: If no spreader bar is used, damage to the module may occur.

Figure 7

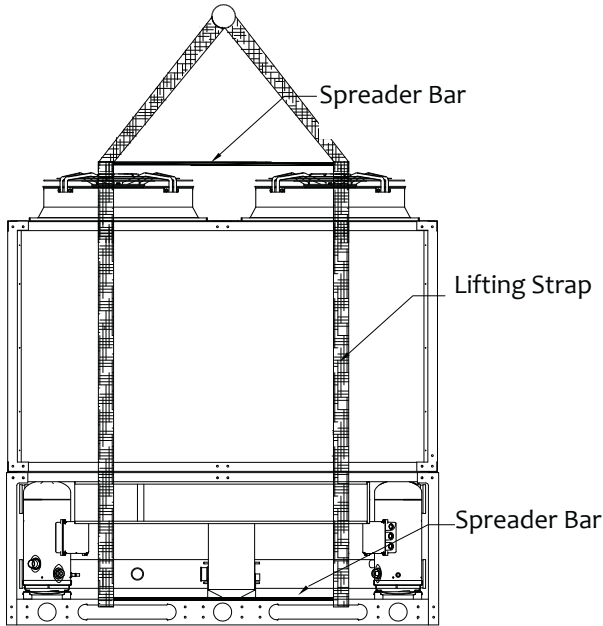

Lifting and Transporting Modules

Forklifts are required for lifting and transporting the module. Each module has base cutouts provided for ease of maneuverability.

Figure 9

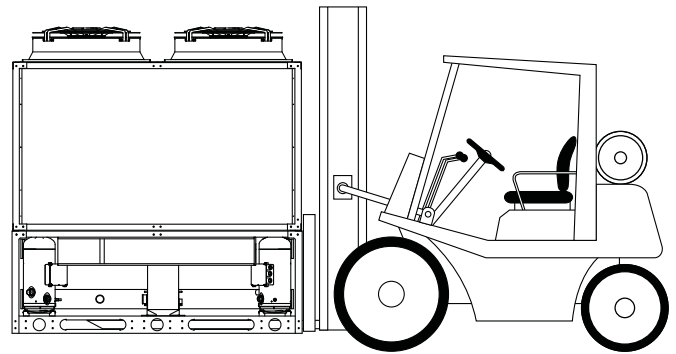
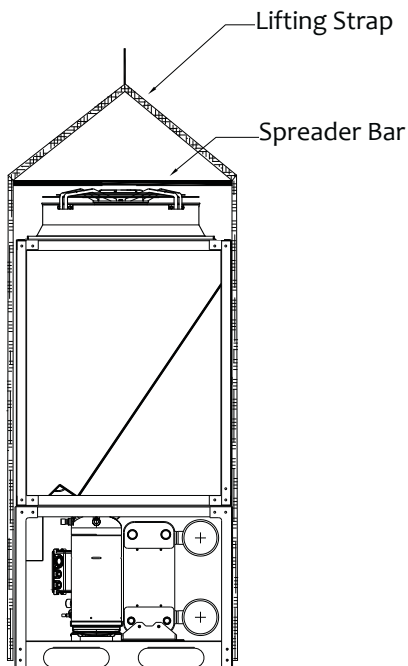

Figure 8



Mounting Rail and Vibration Isolation

ClimaCool recommends locking down the chiller to a concrete base or to two (2) 4" base mounting rails using the six bolt holes provided in each base pan (see Figure 10). Due to the low vibration of the modules, ClimaCool does not require the application of spring isolators or pads. Should isolators or pads be desired, install in accordance with Figures 11 and 12.

Figure 10 - Support Rails and Anchor Locations

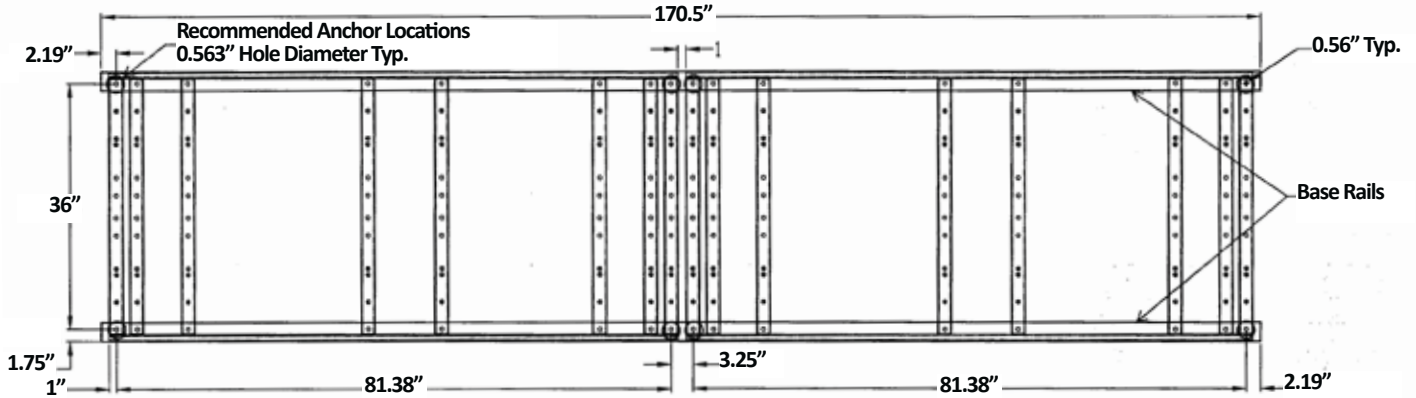

Figure 11 - Spring Vibration Isolators Option

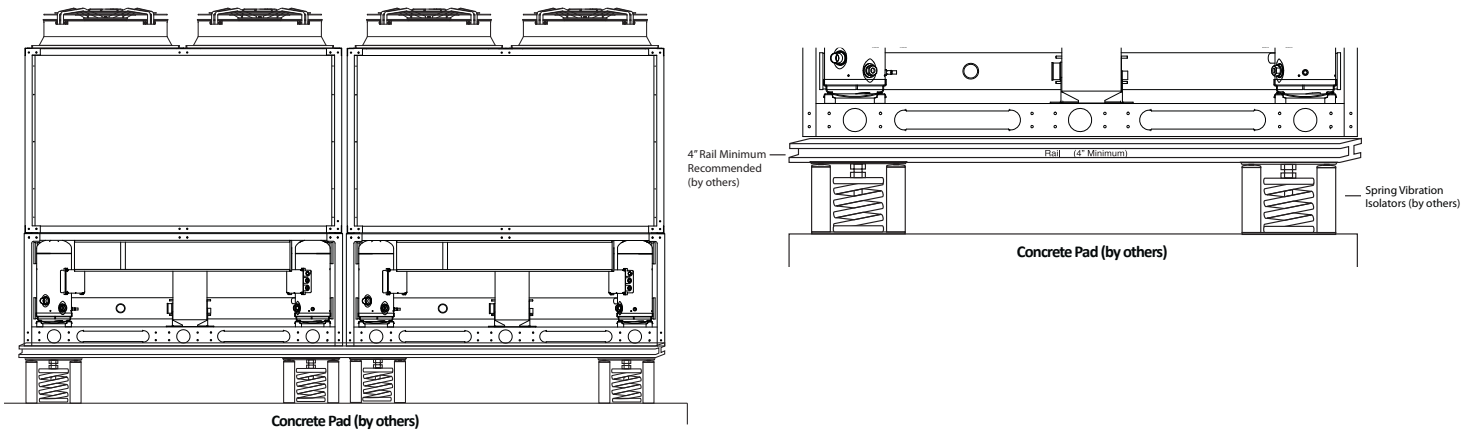
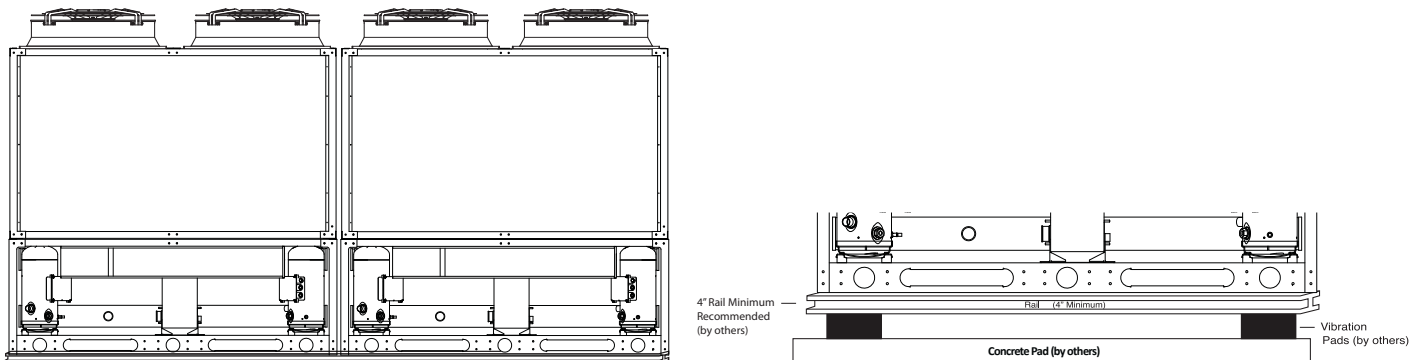

Figure 12 - Vibration Isolation Pads Option



Note: Size and weight distribution is to be determined by a qualified structural engineer per individual job requirements.

Recommended Service Clearances

Figure 13 - End-to-End Configuration

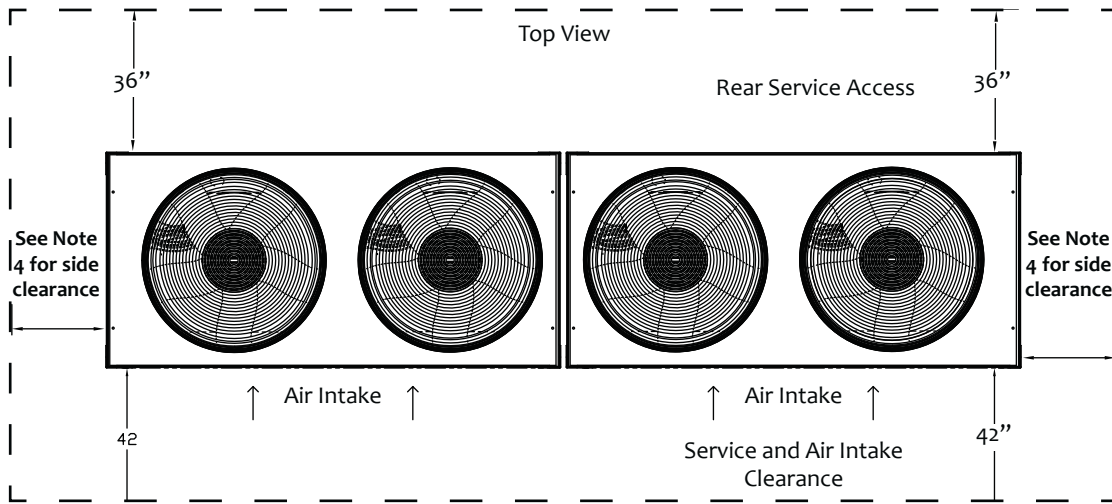
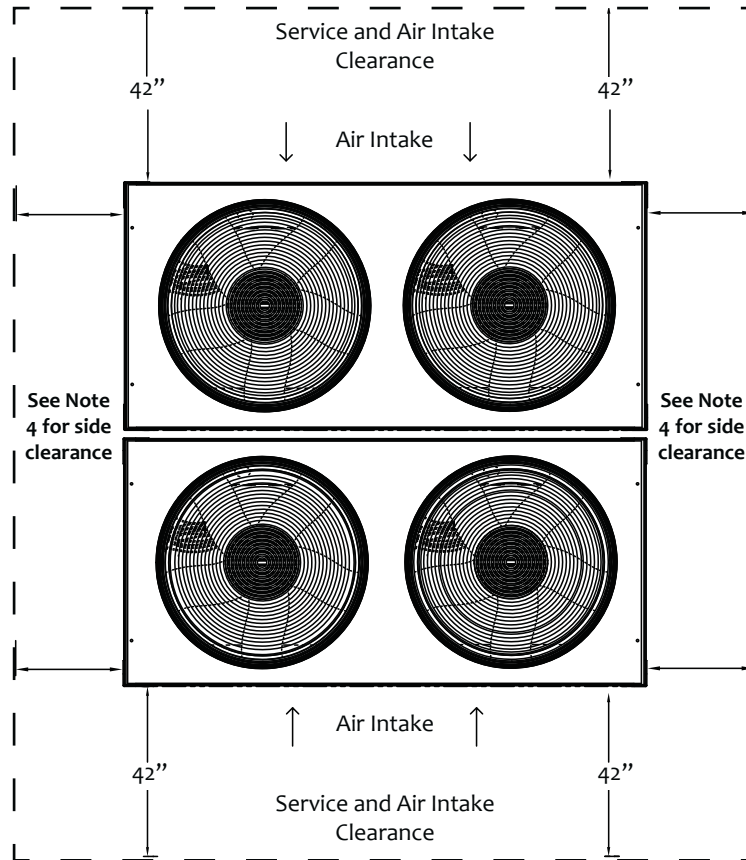

Figure 14 - Back-to-Back Configuration



Notes:

1. UCA/UCF 20 and 30 ton modules, end-to-end configuration require 42" clearance for electrical panels and 36" clearance for rear service access.
2. UCA/UCF 20 and 30 ton modules, back-to-back configuration require 42" clearance for all service and air intake sides.
3. UCA 50, 70 and UCF 70 ton modules can only be installed in the end-to-end configuration and require 42" clearance for both service and air intake sides.
4. Allow an unobstructed height clearance for airflow.
5. Local building or electrical codes may require additional clearance. Consult applicable codes.
6. Provide side clearance as required for field piping connections and components.

Ultimate Chiller Solution Model Key

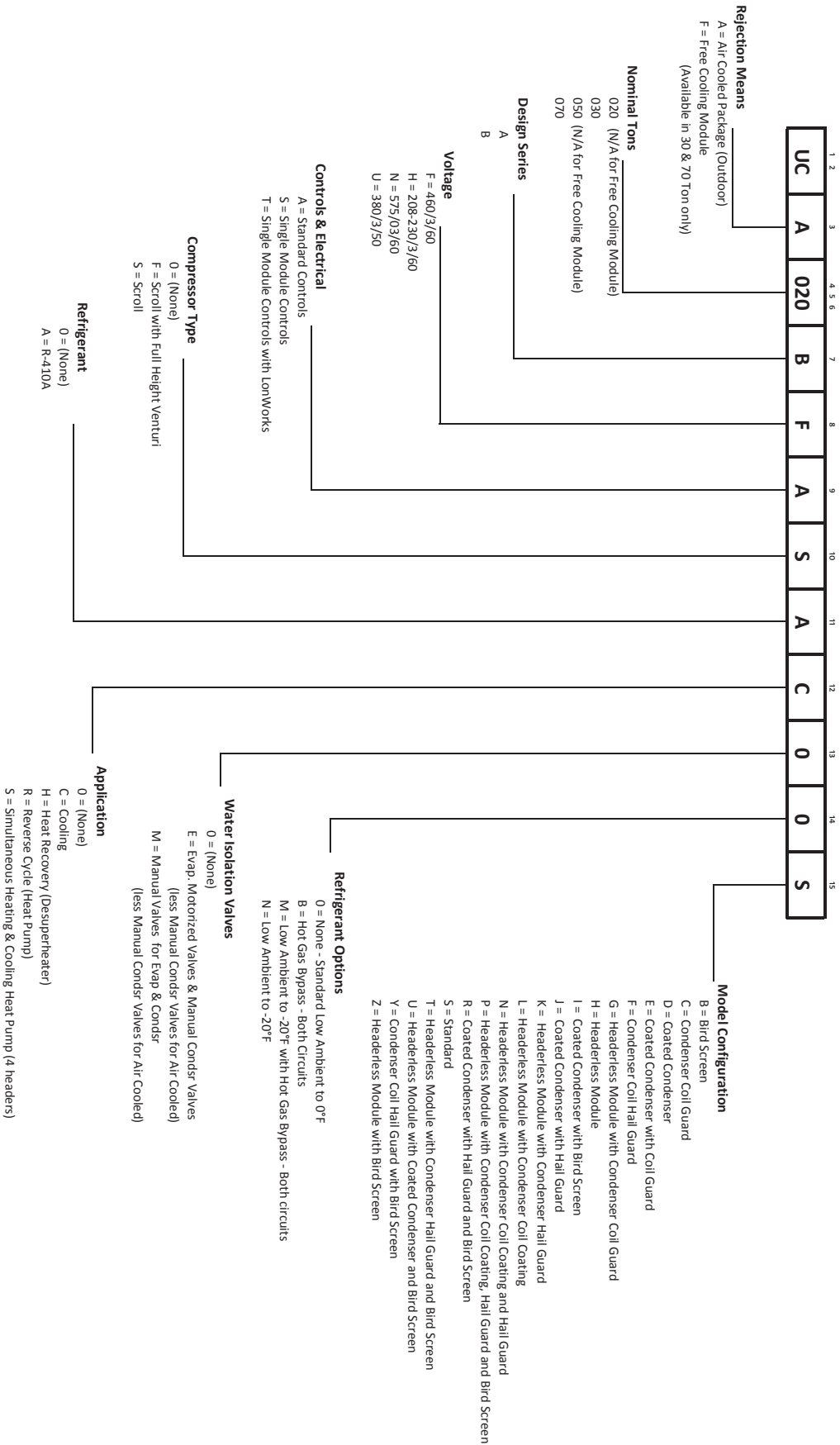

Unit Installation

Foundation for Unit Placement

The minimum foundation requirement for the ClimaCool chiller is a level surface capable of bearing the combined operating weight of the modules (See Physical Data - page 3-5).

Service Access

Recommended Service Clearances and Bank Dimensions shown on page 11.

Draining

When performing standard maintenance procedures such as flushing a heat exchanger, it will be necessary to close off a section of a module. ClimaCool modular chillers offer optional water isolation valves for this purpose.

Assembling Modules

ClimaCool recommends locking down the chiller to a concrete base, or to two (2) 4" base mounting rails using the bolt holes provided in the unit base. Although the compressors are installed on anti-vibration mountings, further isolation of the chiller from the structure is available by installing vibration eliminating springs or pads under the base rails on which the chiller will rest (See page 10 – Mounting Rail and Vibration Isolation). One end of the modules should be chosen as the reference module and carefully located.

Field installed mounting accessories are provided for adjoining each module.

- Header grooved coupling kits containing two (2) for water cooled and heat pump applications and four (4) for simultaneous heat pump applications.
- Mounting hardware kit containing necessary bolts, spacers, nuts and washers.
- Header bank end cap kit containing two (2) each for water cooled and heat pump and four (4) each for simultaneous heat pump applications.
- Groove by groove 6" nipples, one (1) required per header.

Field installing the mounting hardware kit will assist with alignment of the modules in a bank and eliminate offset inconsistencies. The arrows in Figure 16, page 14 show the end to end and back to back holes for the 1" spacers between the units. The spacers will allow for an 1" separation between modules in both the end to end and back to back configurations.

Once the spacers are installed, the distance from the outside corner post upright to the adjacent outside corner post upright will be 1". Using the appropriate tools tighten hardware assembly until seated.

Inspect the pipe ends to ensure they are free from any indentations, projections, roll marks or other harmful surface defects such as loose paint, scale, dirt, chips, grease and rust. Inspect the grooved coupling gasket for any defects. Apply a thin layer of silicone or other non-petroleum lubricant to the sealing lips of the gasket and to the exterior of the gasket. Install gaskets on the pipe ends of one of the two modules to be mated. **Be sure the gasket is completely on the pipe so damage will not occur in the next step.**

One groove by groove 6" nipple per header is required to complete the connection between each module. Move the second module into position and line up the piping. Ensure you are maintaining alignment for any additional modules to be added. When pipe ends are aligned, slide the gasket over the ends and center it between the grooves. No part of the gasket should protrude into the groove of either pipe end. Place the coupling halves over the gasket and make sure that the coupling keys, (the part that goes into the groove), are engaged into the grooves. Insert the bolts and install nuts to hand tight. Make sure that the oval neck of the bolt engages into the bolt hole of the housing. **Tighten nuts alternately and equally until the bolt pads meet and make metal to metal contact.** Tighten nuts by another 1/4 to 1/2 turn to make sure the nuts and bolts are snug and secure; the use of a torque wrench is usually not required. **Uneven tightening of bolts may cause the gasket to be pinched resulting in immediate or delayed leaks.**

Assembling Modules Back to Back

To assemble module in a back to back configuration, see Figure 17.

- Remove zip tie from lower 2" flexible hose on the header-less unit.
- Loosen the lower 2" grooved coupling from the bottom header and remove the end cap.
- Lubricate the rubber gasket with approved grooved coupling lubricant.
- Insert the end of the flexible hose from the header-less unit into the 2" grooved coupling on the header where the end-cap was previously removed.
- Equally tighten the 2 bolts to 15 to 22 ft-lbs of torque.
- Repeat above procedure for the upper hose connection.

Unit Installation

Figure 15 - Hardware Kit



Figure 17 - Back to Back

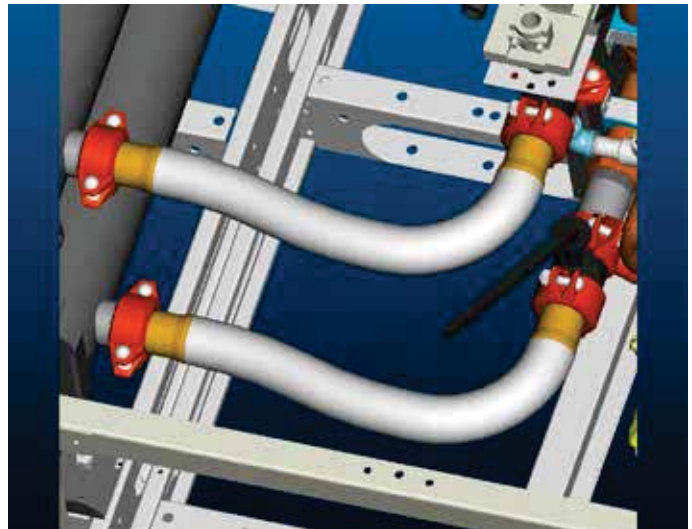

Header Insulation

Chilled water piping is pre-insulated on each module at the factory with 3/4" closed cell insulation. **After bolting all modules together and leak testing, the entire coupling connection will need to be insulated by the installing contractor.**

Figure 16 - Spacer Holes

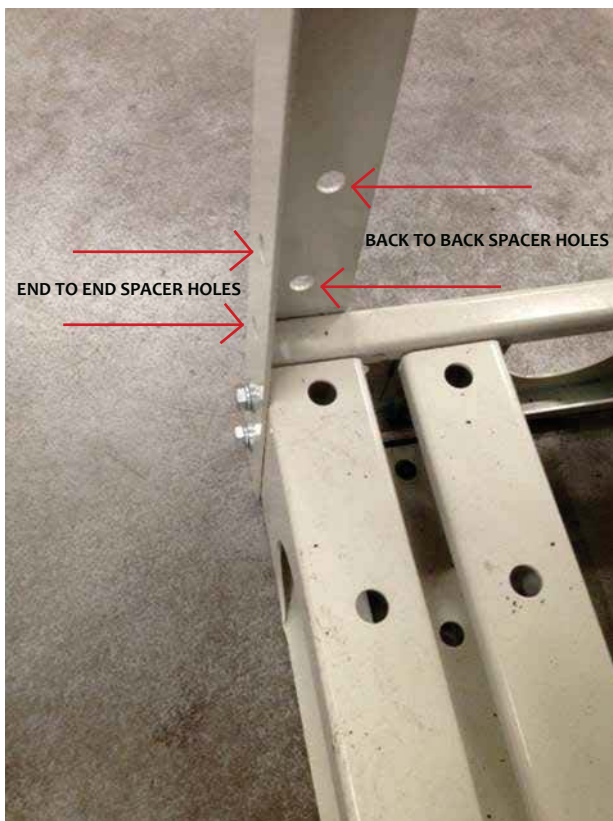

Access Panels

To operate efficiently, side access panels shipped with the module, must be in place before installing adjacent module and always prior to operation of the bank. Lower side access panels are available as an option.

Electrical Connection

The power for modules is taken from a suitable circuit breaker/fused disconnect power supply within the main panel. The electrical service enters the individual modules through the upper right side of the module's control panel enclosure. Proper grounding of the module is mandatory. **Before carrying out any electrical work, confirm that the main supply is isolated.** A typical power wiring is located on page 55 – Power Distribution Drawing. Knockout drawings are provided. **Do not drill into cabinet;** shavings can damage electronic components. The power for all individual modules shall be in compliance with all local and national codes.

CoolLogic Control System Wiring

A separate 115 volt power supply is required to power the CoolLogic Master Control Panel. Communication between the Master Controller and chiller modules requires a simple two-conductor, 18 AWG shielded cable rated at 60°C minimum, daisy chain connection. **Control wiring cannot be installed in the same conduit as line voltage wiring or with wires that switch highly inductive loads such as contactor and relay coils.** Refer to the Power Distribution schematic on page 52 and Wiring Diagrams on pages 82-84 of this manual for more information. All wiring shall be in compliance with all local and national codes.

Electrical Phase Sequencing

Proper clockwise rotation for scroll compressor motors is important to prevent damaging the compressors. ClimaCool recommends the use of a phase sequence indicating instrument following the manufactures directions. Another alternative would be to “bump test” the compressors one at a time with pressure gauges attached to the high and low gauge ports of the compressors to check for proper rotation. Energize the compressor for a few seconds to ensure the discharge pressure gauge increases significantly. If the discharge pressure does not increase, proper rotation is reversed. Compressor rotation can be reversed by opening the main electrical disconnect and switching any two of the main power supply leads feeding that compressor's contactor.

⚠ CAUTION/ATTENTION	
3 PHASE SCROLL COMPRESSOR UNITS	UNITÉ DE COMPRESSEUR SCROLL 3-PHASE
<p>If this unit uses a 3 Phase Scroll Compressor, the following instructions MUST BE followed:</p> <ul style="list-style-type: none"> Unit power supply MUST BE wired in the proper sequence to avoid damage to the 3 Phase Scroll Compressor; Scroll Compressors with INCORRECT rotation show the following characteristics: <ul style="list-style-type: none"> High sound level; High suction pressure and low discharge pressure; Low current draw. If any of the three above characteristics exist, swap two of the three supply wires at the disconnect and recheck compressor for incorrect rotation. 	<p>Si cet appareil utilise compresseur scroll 3-Phase, les instructions suivantes doivent être suivies:</p> <ul style="list-style-type: none"> L'alimentation de l'appareil doit être monté dans l'ordre correct pour éviter endommager le compresseur scroll 3-Phase Compresseurs scroll avec rotation incorrecte montrent les caractéristiques suivantes: <ul style="list-style-type: none"> Haut niveau de son; Pression d'aspiration élevée et une faible pression de décharge; Faible ampérage Si l'un des trois éléments mentionnés ci-dessus sont remplies, échanger deux des trois lignes électriques alimentant l'interrupteur de sécurité et vérifier la rotation du compresseur.

Proper Voltage Balance

Occasionally, in three phase circuits, a voltage imbalance occurs between phases. It is not recommended to operate equipment when an imbalance greater than 2% occurs. This causes motors to run at high temperatures and may affect their longevity. The following example describes how to calculate the average voltage of the three phases to see if the imbalance is greater than 2%.



Example: Line 1 = 226v Line 2 = 230v Line 3 = 228v
The average is: $(226+230+228)/3 = 228v$

Next, $[100(228-226)]/228 = 0.9\%$

The voltage imbalance of the three phase circuit is 0.9%. This is well under the 2% range.

Voltage/Phase Monitor

Voltage/phase monitors are factory supplied for field installation with the CoolLogic Master Control Panel. The voltage/phase monitor helps guard the chiller bank against voltage fluctuations, phase failure or phase reversal conditions which could void your warranty. The voltage/phase monitor has three wires that connect to the main three phase power chiller bank input. Two low voltage control wires are connected to the CoolLogic Master Control Panel. Do not install control wiring in the same conduit as line voltage wiring or with wires that switch highly inductive loads such as contactor and relay coils. **Note:** It is mandatory to install one (1) monitor per bank at main power distribution panel to monitor voltage and phasing of power to the modules. See Wiring Diagram on page 16.

⚠ WARNING/AVERTISSEMENT		
<p>Disconnect power supply (ies) before servicing. Refer servicing to qualified service personnel. Electric shock hazard. May result in injury or death!</p>		<p>Debrancher avant d'entreprendre le dépannage de l'appareil. Consulter un réparateur qualifié pour le dépannage. Risque de choc électrique. Résultat de mai dans dommages ou la mort!</p>
⚠ CAUTION/ATTENTION		
<p>Unit to be serviced by qualified personnel only. Refrigerant system under pressure. Relieve pressure before using torch. Recover refrigerant and store or dispose of properly.</p>		<p>Conifer la maintenance à un technicien qualifié. Le système frigorifique sous pression. Décompresser avant d'exposer à la flamme. Récupérer le frigorigène et le stocker ou le détruire correctement.</p>

CAUTION/ATTENTION	
<p>Use only copper conductors for field installed wiring. Unit terminals are not designed to accept other types of conductors.</p>	<p>Utilisez uniquement des conducteurs en cuivre pour le câblage. Bornes de l'unité ne sont pas conçus pour accepter d'autres types de conducteurs.</p>

Wiring Diagram-Voltage/Phase Monitor

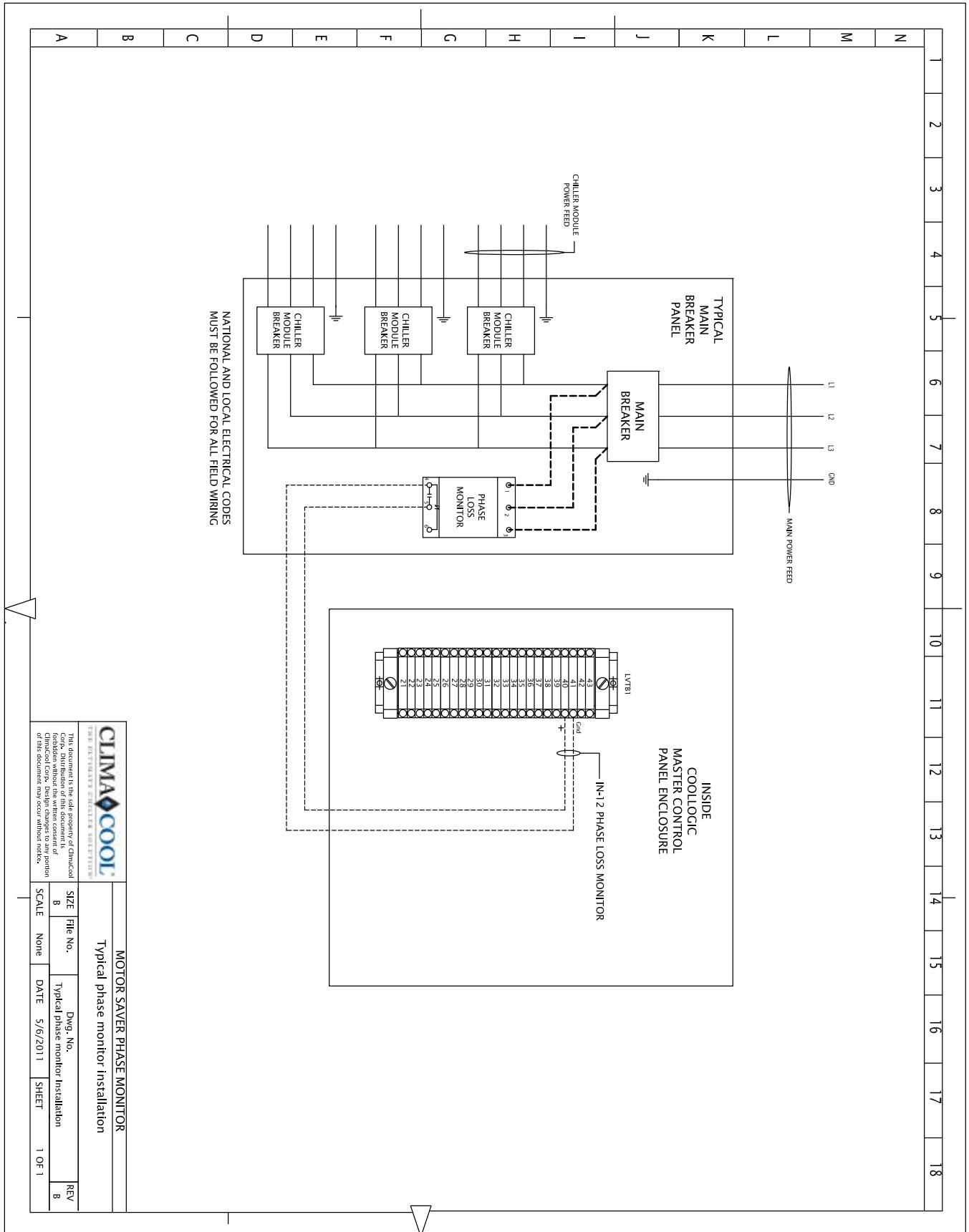

The document is the sole property of ClimaCool Corp. Distribution of this document is of ClimaCool Corp. Design changes to any portion of this document may occur without notice.

MOTOR SAVER PHASE MONITOR		SIZE	File No.	Dwg. No.	REV
Typical phase monitor installation		B			B
SCALE	None	DATE	5/6/2011	SHEET	1 OF 1

Water Piping

As with any water system, it is important that the system be clean. The pipe work installer must remove weld scale, rust and contamination during pipe work fabrication. The system water piping must be flushed thoroughly with recommended alkaline flush or other chemicals that are compatible with 316 stainless steel prior to making connections to the ClimaCool chiller. There are certain necessary components that should always be installed in the chilled water system. (See Figures 21 and 22 on page 19 - Water Piping Configurations for configurations with multiple modules). All water piping must be installed in accordance with applicable codes and standards.

Temperature Sensor and Wells

ClimaCool provides two (2) temperature sensors and wells with each two pipe chiller system and four (4) with simultaneous heating & cooling four pipe chiller systems configured by the CoolLogic Control System. They must be field installed a minimum of 36" but no more than 60" away from the bank and before the strainer on the chilled water inlet and chilled water outlet (See Water Piping Configurations – page 19). **Note: Sensors must be fully inserted into the well to obtain proper readings. Use a slender, blunt instrument to gently push the sensor to the bottom of the sensor well.**

Pressure Differential Flow Sensor

It is imperative that minimum and maximum water flow rates, as defined in the Operational Limitations on page 26, are not exceeded. To prevent operation of the chiller without sufficient water flow to the evaporator, it is required to install a pressure differential flow sensor in the chilled water circuit. Place downstream of the strainer on the outlet of a straight pipe, as close to the module as possible. **Do not put in an elbow on the outlet.** When connecting tubing to the differential pressure sensor, be sure to bleed any air from the tubing before tightening. (See Water Piping Configurations – page 19).

Pressure Taps

The installing contractor must provide access ports for connecting the pressure differential flow temperature sensors and pressure gauges for the chilled water system. A 1/4" pressure tap is required on the inlet and the outlet of the chilled water system for a total of four (4) taps with each two (2) pipe chiller system and six (6) with each simultaneous heating and cooling four pipe chiller system. If a port is shared by the pressure differential flow sensor and the pressure gauge it will require two (2) 1/2" taps. (See Water Piping Configurations – page 19).

Water Isolation Valves

It is recommended to provide bank water isolation valves for proper isolation and maintenance of the chiller, pump and strainer (See Water Piping Configurations – page 19).

Strainers – Minimum 60 Mesh Screen Required

ClimaCool chillers utilize brazed plate heat exchangers which are extremely sensitive to debris. **Therefore, it is mandatory that all chilled water systems include a strainer with a minimum of 60 mesh screen for proper filtration.** The strainer must be installed as shown in the Water Piping Configurations on page 19 and be in place at all times when the chiller is operating. **ClimaCool's warranty does not cover and does not apply to products which have defects or damages due to freezing of the water supply, an inadequate or interrupted water supply, corrosives or abrasives in the water supply, or improper or inadequate filtration or treatment of the water supply.**

Chiller/Heater System Water Header Bypass

A bypass is required for any load cooling, cooling only and load cooling and load heating, simultaneous heating and cooling heat pump with variable pumping. The chiller bank bypass must be piped in such a way that the temperature and pressure differential flow sensors are still sensing active flow. (See Water Piping Configuration – page 19). The purpose of the chiller/heater system bypass is to prevent deadheading of the pumps when all of the internal unit valves go closed as well as allow temperature and differential pressure sensors to sense active flow. The bypass should be sized for an absolute minimum of one module's worth of design flow. (Please refer to selection submittals for design flow rates).

Modules can be designated for fixed bypass for heating, cooling, however, this limits the number of modules remaining for that duty. Also, with a module acting as a bypass increased wear of heat exchangers may be caused by abrasion from bypass flow.

Figure 18 - Reverse Return

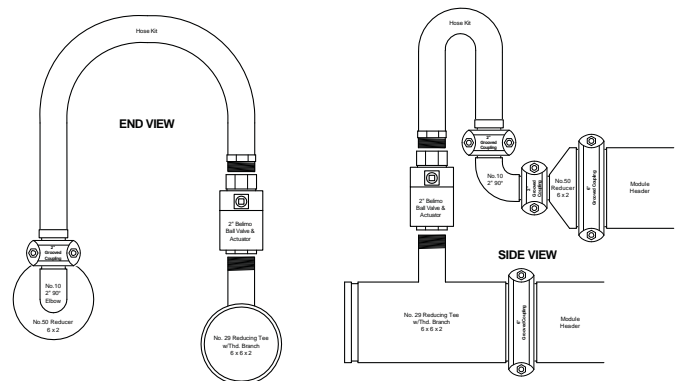

Water Piping

Figure 19 - Direct Return

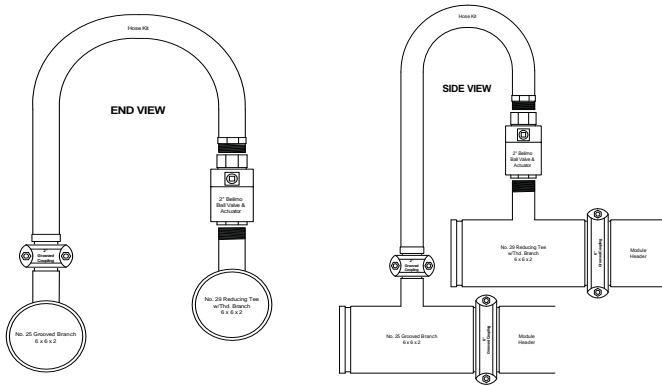
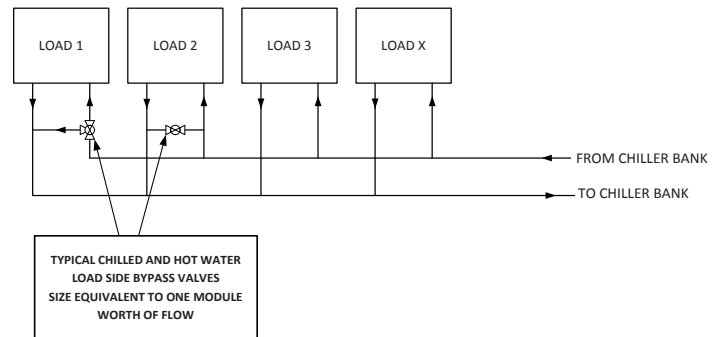

Figure 20 - Typical Load Bypass Valve Arrangement



Load Side System Bypass (Air Handlers, Fan Coils, etc.)

A load system bypass is required for preventing pump deadheading, allowing active flow system sensing and preventing starving flow from the chiller/heater system. Examples of an acceptable load side system bypass are:

- Utilize a quantity of 3-way control valves on the largest loads farthest from the chiller/heater system.
- Field piping with a control valve to provide a bypass across the larger system loads when their 2-way valves go closed.

Please refer to Figure 20 for a typical load bypass valve arrangement. The load side system bypass should be sized for an absolute minimum of one module's worth of design flow. (Please refer to selection submittals for design flow rates). A minimum of (6) six gallons per nominal system ton are also required to maintain proper system thermal inertia. This is to avoid short cycling of compressors in the chiller/heater system as well as prevent nuisance alarms.

ClimaCool offers two types of water header bypass kits, reverse return (Figure 18) and direct return (Figure 19). The bypass kits must be installed on each water source loop and controls are integrated with the CoolLogic software. Installation location can be found on page 19 – Water Piping Configuration.

This bypass can also be created with field supplied piping. The design piping must accommodate one module's worth of design flow, and be positioned so that the temperature and differential flow sensors sense active flow in the bypass mode. (See Water Piping Configuration – page 19). **The field supplied piped chiller/heater system bypass must be controlled by others.** There are system communication delays, polling and network conflicts that strictly prohibit the use of ClimaCool sensors and controls for control of field supplied bypasses or other field supplied items. Recommended method is to control via differential pressure or gpm flow meters across the load cooling/load heating and heating water systems.

Figure 21 - Field Piping Direct Return - 1 to 5 Modules

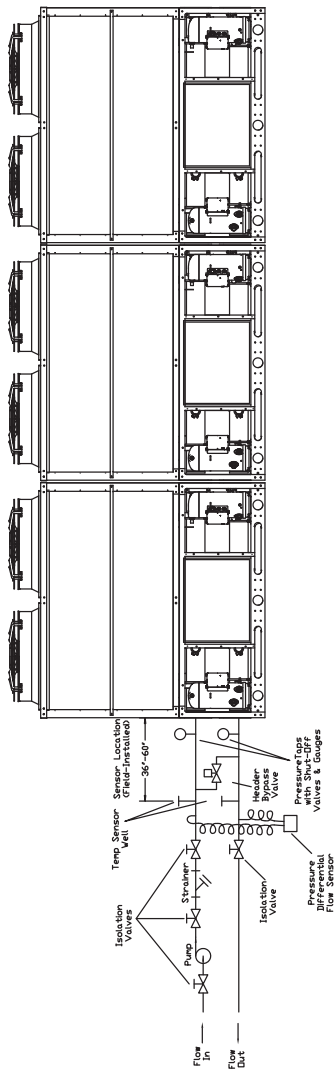
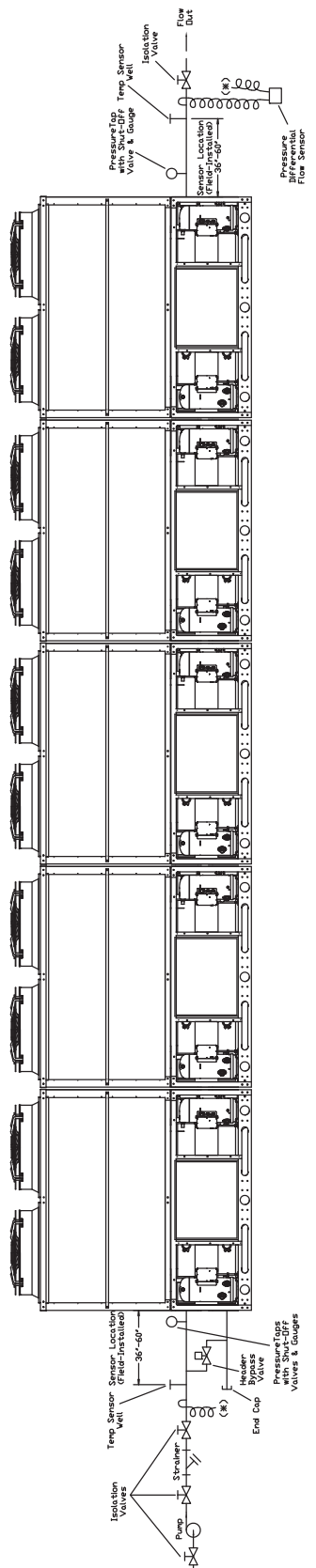

Figure 22 - Field Piping Reverse Return (Preferred 1 to 5 modules) Required for more than 6 modules



Notes:

1. Figures 21 and 22 are required piping for proper water regulation and distribution through ClimaCool modular chillers.
2. Module order and incoming/outgoing water flow, as shown in both Figure 21 and 22, can be set up as either a left-to-right or right-to-left configuration.
3. For chilled water (evaporator and hot water on simultaneous heating & cooling) inlet/outlet location dimensions, refer to pages 6-8 - Dimension Data and Drawings.
4. A pressure differential flow sensor is a required safety device for ClimaCool modular chillers on the chilled water circuit.
5. A strainer with a minimum of 60 mesh stainless steel screen is a required safety to protect the brazed plate heat exchanger on the all water sides of the system and must be in place at all times when the chiller is operating.
6. Maximum water flow rates for the evaporator water header system in one bank of modules is 1,000 GPM.
7. Bypass is **mandatory** for systems utilizing motorized valves.
8. Header bypass valve may be installed at either end of bank.
9. For over seven (7) modules, please consult the factory.

Hydronic Refrigeration

Figure 23 - Chilled Water Circuit

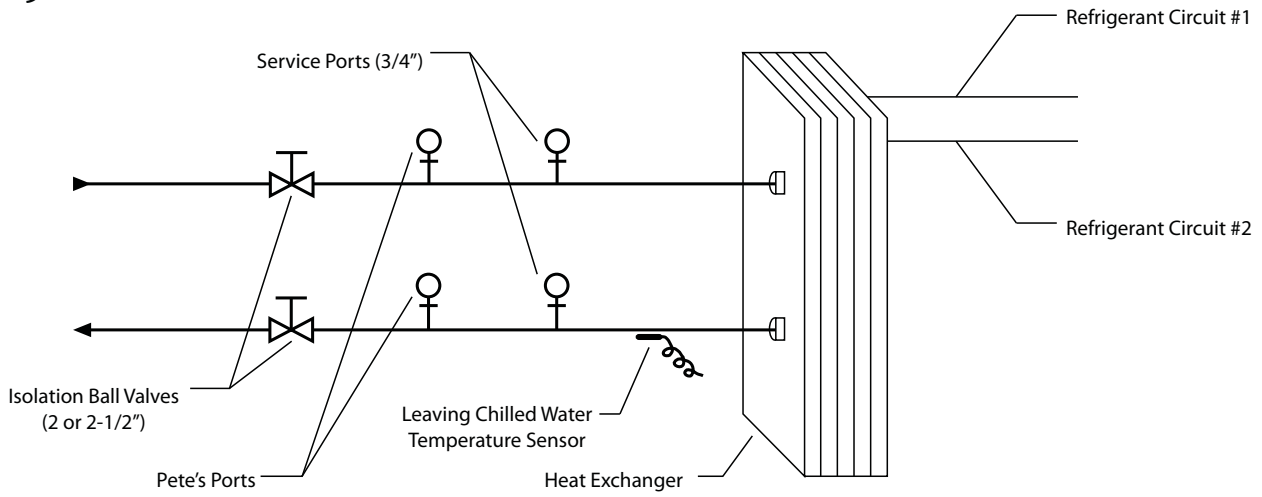

Note:

Figure 23 depicts hydroponic piping in each ClimaCool chiller module and is shown with water isolation valves.

Part-Load Performance Advantage

Figure 24

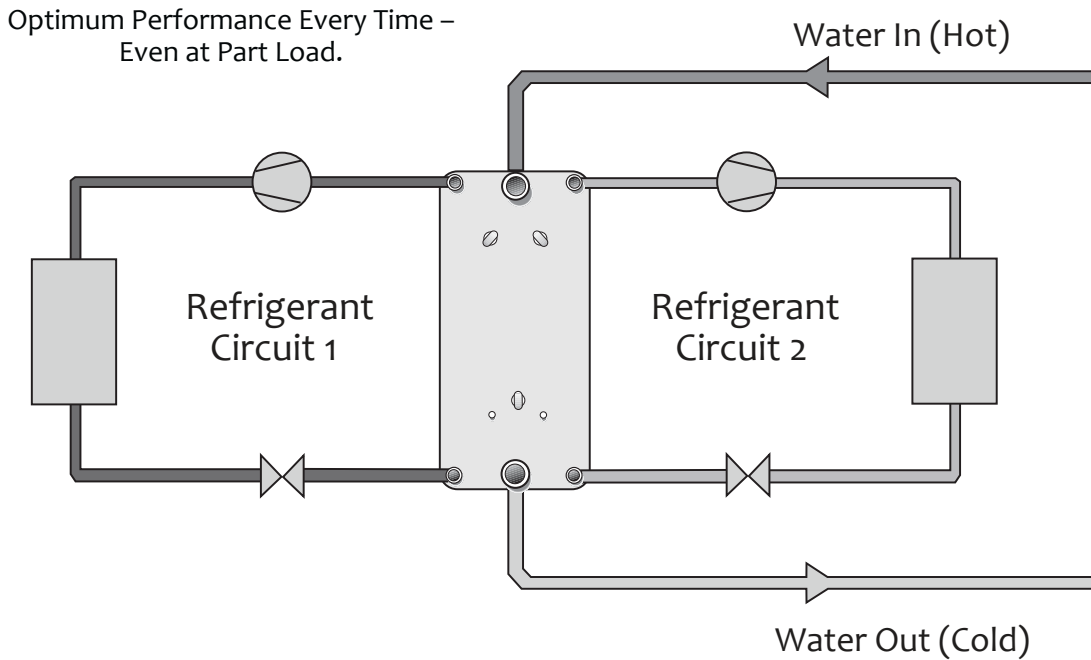

ClimaCool modular chillers employ reliable and highly efficient brazed plate heat exchangers. These compact exchangers are true dual-circuit heat exchangers in which each water channel is flanked by two refrigerant circuits. This design gives maximum performance, even at part-load.

Of course, full performance is attained when the dual-circuit heat exchangers are run to full-load (i.e. with both refrigerant circuits).

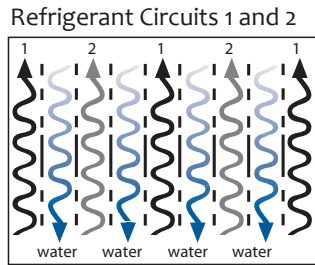

If circuit 1 is cut, the unique design allows each water channel to remain in contact with refrigerant circuit 2, providing optimum heat transfer.

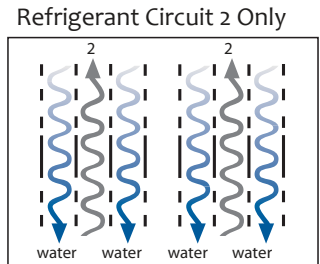

The same results are achieved if circuit 1 is ran and circuit 2 cut out; optimum heat transfer, even at part-load.

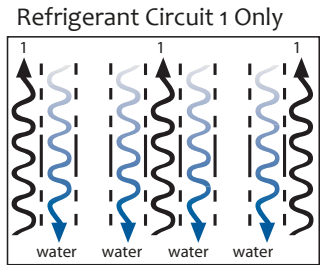

Filling the Water System

It is imperative that the water systems are free from debris prior to initial operation. See Water Treatment for a comprehensive list of precautions on page 22.

Filling, Purging and Leak Testing the System

After the water systems have been properly installed, visually inspect all joints for tightness. If the chiller is to be installed in an existing system, the cleanliness of the existing system can be judged from the operating conditions of the present machines. It is good practice to flush and, ideally, to acid wash the existing system **before** connecting a new chiller.

The following method is recommended to fill and leak check the water system for modules **WITH** Water Isolation Valves:

1. Close all water isolation valves inside each module which isolate the individual heat exchangers.
2. Ensure that all drain valves are closed and that all water main isolation valves are opened.
3. The system should be filled with clean water sent through the strainers and the system checked for leaks.
4. Once the main water lines and the chiller headers are filled with clean water, purge and repeat the filling process at least three times.
5. All modules are equipped with ¾" fill and flush valves with lines teed into the inlet and outlet connections into and out of each heat exchanger. Ensure these ¾" valves are **CLOSED**.
6. Open the water isolation valves inside each modular chiller and repeat the filling process, this time also checking for leaks inside each module.
7. Following the final filling and leak checking procedure, air should be purged from the system.

The following system is recommended to fill and leak check the water system for modules **WITHOUT** Water Isolation Valves:

1. Ensure that all drain valves are closed.
2. All modules are equipped with ¾" fill and flush valves with lines teed into the inlet and outlet connections into and out of each heat exchanger. Ensure these ¾" valves are **CLOSED**.
3. The system should be filled with clean water sent through the strainer and the system checked for leaks.
4. Once the main water lines and the chiller headers are filled with clean water, purge and repeat the filling process at least three times.
5. Following the final filling and leak checking procedure, air should be purged from the system.

Cleaning the System

The following method is recommended to properly clean the water systems:

1. Before cleaning the system, install a temporary bypass line between the main supply and return water headers of both chilled and condenser water systems when possible. Open the main header bypass lines to divert the initial water flow around the module heat exchangers until you are confident the circulating water is mostly pure.
2. Provided main header bypass lines are installed, close all water isolation valves inside all modular chillers equipped with manual or automatic water isolation valves. If the modules are **NOT** equipped with water isolation valves, we recommend installing 3-way main header bypass valves so the initial water flow bypasses all module heat exchangers.
3. It is mandatory to run the pumps with the strainers in place (see Starting the Pumps section below for proper pump startup). All external hydronic branches should be open to all devices in the system.
4. Pressure drop across the strainer must be observed and as pressure change reaches 50% of the initial read, strainers must be isolated and cleaned.
5. Open all water isolation valves inside each module equipped with manual or automatic water isolation valves (see step 6 for modules **NOT** equipped with water valves). If bypass lines are not installed (described in step 1) it is recommended to drain out the initial fill of water to help flush out debris. Close off the main header bypass lines referred to in step 1 and open the flow to the main water headers. Repeat steps 3 and 4 until there is no more debris being collected by the strainers.
6. If bypass lines are not installed (described in step 1) and the modules are **NOT** equipped with water isolation valves, it is recommended to drain out the initial fill of water to help flush out debris. Remove and clean the strainers before refilling and purging the system again. Repeat steps 3 and 4 until there is no more debris being collected by the strainers.

Starting the Pumps

Follow the manufacturer's recommendations when starting the pumps for the first time. The system should be checked for leaks and air purged with the pumps in operation. The pressure drop across the heat exchangers will give a good indication of flow through the system (See Evaporator Water Pressure Drop Charts on page 25). This should be immediately checked against the expected pressure drop for the flow rate required. **If the pressure drop begins to fall and the flow rate is falling, this could indicate the need to clean the strainers.**

Water Treatment

Water quality is of the utmost importance for the proper care and maintenance of the modular chiller system.

Proper water treatment is a specialized industry and it is recommended to consult an expert in this field to analyze the water for compliance with the water quality parameters listed in Table 1. The materials exposed to the water are type 316 stainless steel, pure copper and carbon steel. Other materials may exist external to the ClimaCool chiller. It is the user's responsibility to ensure these materials are compatible with the treated water. Regular treatment of the water will increase longevity of your system.

Failure to provide adequate filtration or treatment of evaporator and condenser water will void the ClimaCool module's warranty.

Heavy-Contaminated Water

In such instances whereby the particulates in the water are excessive, it is recommended to install an intermediate plate and frame heat exchanger to isolate the ClimaCool chiller from the building water system. from the building water system.

Table 1 - Water Quality Parameters

WATER CONTAINING	CONCENTRATION
Ammonia	Less than 2.0 mg/l
CaCO ₃ Alkalinity	30 - 500 mg/l
CaCO ₃ Hardness	30 - 500 mg/l
Chlorides	Less than 200 mg/l
Dissolved Solids	Less than 1000 mg/l
Iron	Less than 5.0 mg/l
Manganese	Less than 0.4 mg/l
Nitrate	Less than 100 mg/l
pH	7.0 - 9.0
Sulphate	Less Than 200 mg/l

CAUTION/ATTENTION	
Excessive Chlorine, undissolved solids and other improper water conditions WILL DAMAGE the internal heat exchanger & WILL VOID YOUR WARRANTY!	Chlore excessive, solides non dissous et les autres impropres conditions de l'eau, ENDOMMAGERA l'échangeur de chaleur interne et ANNULERA VOTRE GARANTIE!

Water Temperature Requirements

Table 2 - Water Temperature Requirements

Water Temperature Limits	Load Loops	Minimum LWT ⁴	Maximum LWT ⁴
	Chilled Water		20°F ¹
Hot Water		80°F	135°F

Notes:

1. Operating in ambient temperatures below 40°F requires a suitable antifreeze solution.
2. All modules can operate in this range without the need of special controls.
3. A glycol solution additive is required at a lower operating suction temperatures in order to protect the evaporator from freeze-ups.
4. LWT: Leaving Water Temperature.

Evaporator Water Pressure Drop Charts

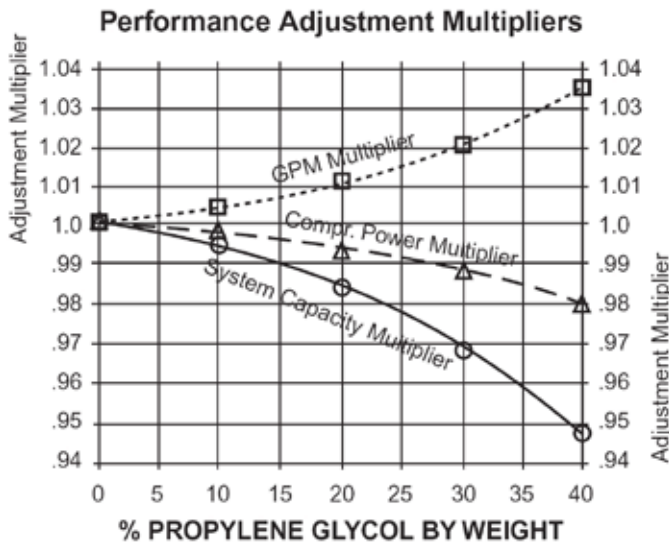
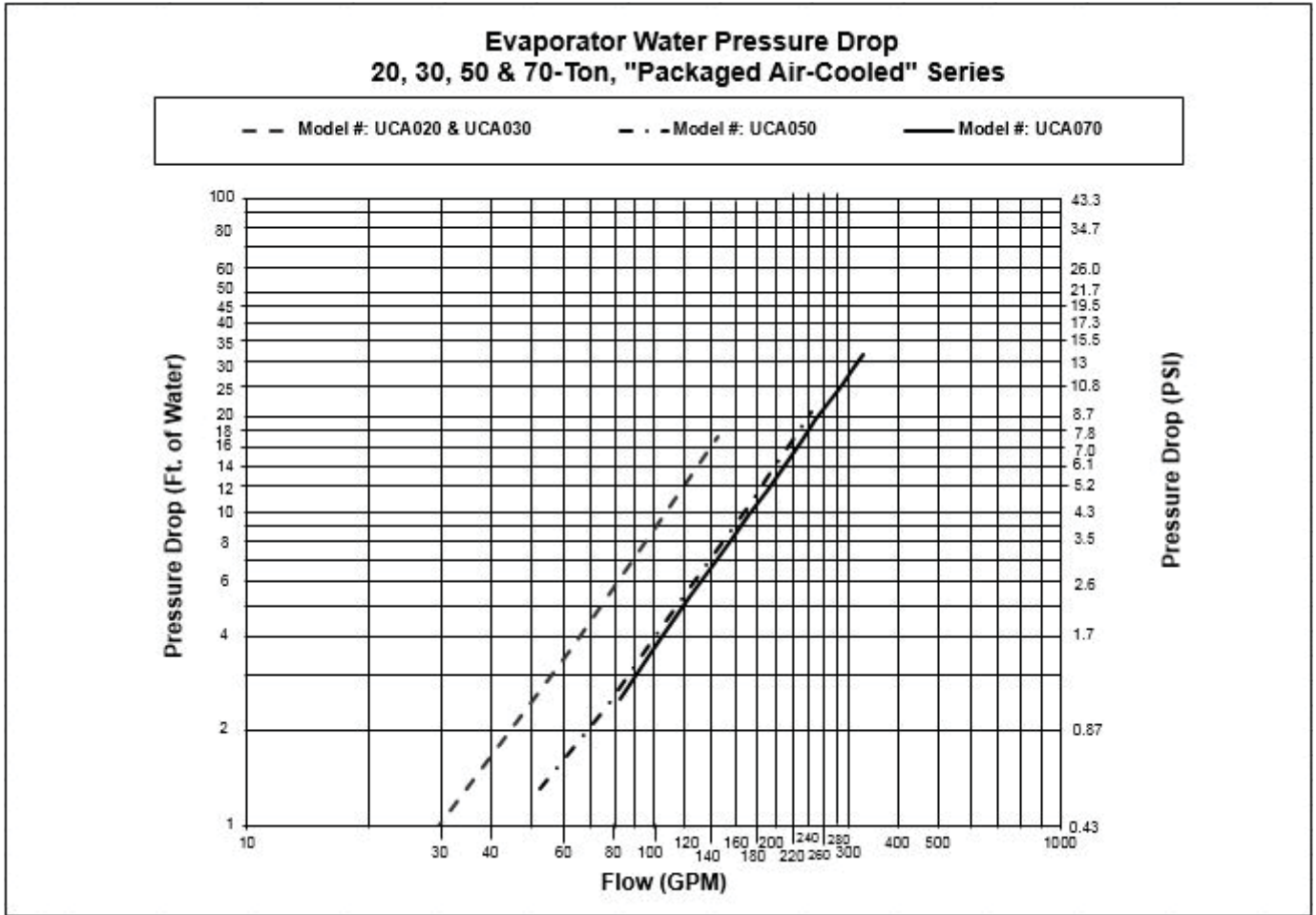

NOTE: Correction factors shown above are to be applied to Std. Product Data @ARI 550/590-1998; 44°F Leaving Chilled Water / 85°F Entering / 95°F Leaving Conditioned Water.

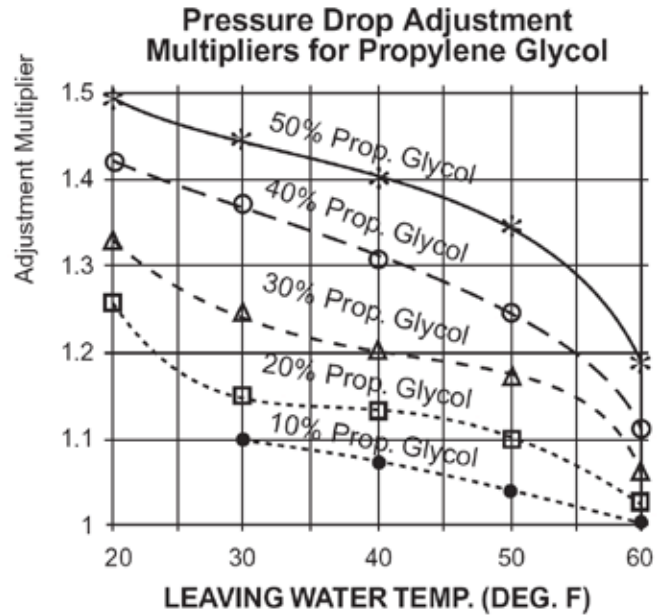

NOTE: Correction factors shown above are to be applied to Std. Product Data chiller pressure drop curves for straight water.

Evaporator Water Pressure Drop Charts

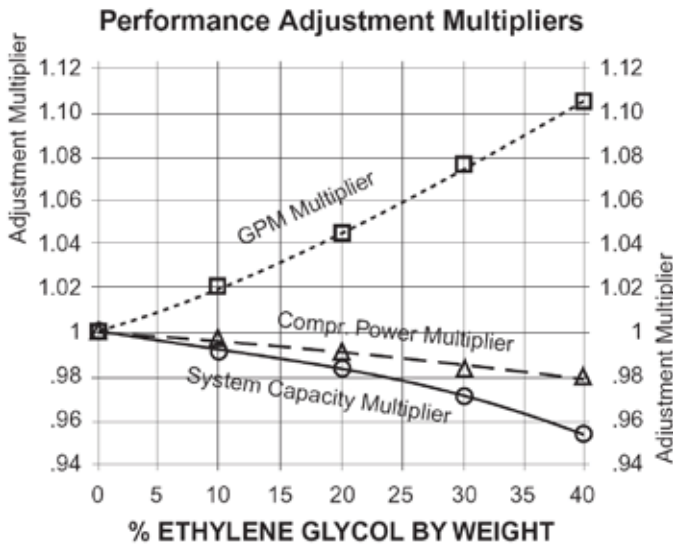

NOTE: Correction factors shown above are to be applied to Std. Product Data @ARI 550/590-1998; 44°F Leaving Chilled Water / 85°F Entering / 95°F Leaving Conditioned Water

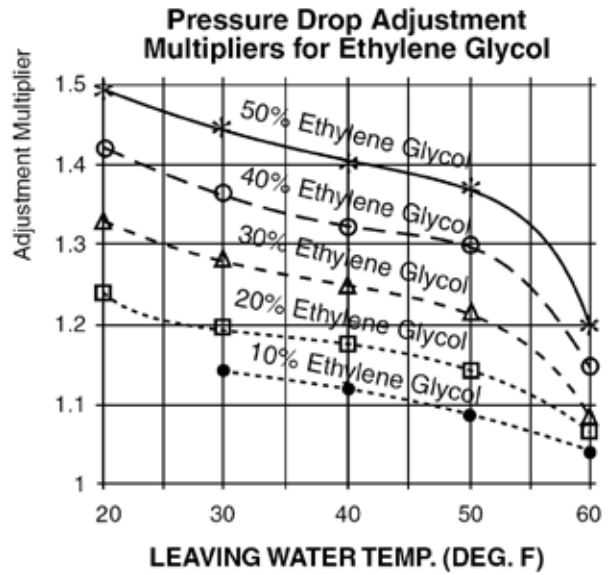

NOTE: Correction factors shown above are to be applied to Std. Product Data chiller pressure drop curves for straight water.

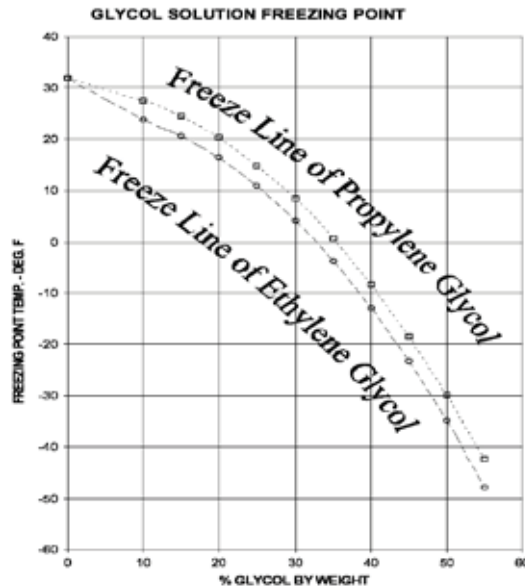

Table 3 - Performance Adjustment Factors vs. Altitude vs. Chiller Temperature Drop

Chiller	Sea Level			2000 ft.			4000 ft.			6000 ft.		
	Capacity Multiplier	Flow gpm Multiplier	kW Power Multiplier	Capacity Multiplier	Flow gpm Multiplier	kW Power Multiplier	Capacity Multiplier	Flow gpm Multiplier	kW Power Multiplier	Capacity Multiplier	Flow gpm Multiplier	kW Power Multiplier
8	0.995	1.246	0.998	0.990	1.244	1.003	0.986	1.238	1.006	0.980	1.232	1.012
10	1.000	1.000	1.000	0.993	0.997	1.004	0.989	0.990	1.007	0.983	0.996	1.014
12	1.005	0.834	1.001	0.996	0.831	1.004	0.992	0.826	1.008	0.986	0.821	1.016
14	1.010	0.716	1.001	0.998	0.714	1.005	0.994	0.709	1.009	0.989	0.704	1.018

Operational Limitations

Table 4 - Voltage Limitations

Voltage Limitations		
The following voltage limitations are absolute and operation beyond these limitations may cause serious damage to the compressor.		
Nominal Voltage	Minimum Voltage	Maximum Voltage
208/230/3/60	187	253
460/3/60	414	506
575/3/60	518	632

Table 5 - Compressor Operating Limitations

Compressor Operating Limitations	UCA
Maximum Compression Ratio	5.7:1
Minimum Operating Pressure Differential (psi)	85
Maximum Operating Pressure Differential (psi)	475
Minimum Discharge Pressure (psig)	235
Maximum Discharge Pressure (psig)	590
Minimum Suction Pressure (No Glycol)(psig)	95
Minimum Suction Pressure (With Glycol)(psig)	70
Maximum Suction Pressure (psig)	155
Maximum Discharge Temperature (°F)	265
Minimum Subcooling (°F)	5
Maximum Subcooling (°F)	15
Minimum Superheat at Compressor (°F)	6
Maximum Superheat at Compressor (°F)	18
Maximum Oil Temperature (Max) (°F)	200
Maximum Saturation Discharge Temperature (°F)	145

Table 6 - Straight Cool Chiller Water Flow and Air Temperature Data

Straight Cool Chiller Water Flow & Air Temperature Data	UCA020	UCA030	UCA050	UCA070
Minimum Evaporator Water Flow (gpm)	23	34	54	78
Maximum Evaporator Water Flow (gpm)	113	164	265	379
Minimum Leaving Evaporator Water Temperature (No Glycol)(°F)	40	40	40	40
Minimum Leaving Evaporator Water Temperature (with Glycol)(°F)	20	20	20	20
Maximum Leaving Evaporator Water Temperature (°F)	60	60	60	60
Minimum Evaporator Water Differential Temperature (°F)	4.5	4.5	4.5	4.5
Maximum Evaporator Water Differential Temperature (°F)	20	20	20	20
Minimum Entering Condenser Air Temperature (°F)	0	0	0	0
Minimum Entering Condenser Air Temperature with -20°F Low Ambient Option	-20	-20	-20	-20
Maximum Entering Condenser Air Temperature (°F)	115	115	115	115

Table 7 - Heat Pump Chiller Water Flow & Air Temperature

Heat Pump Chiller Water Flow & Air Temperature Data	UCA020	UCA030	UCA050	UCA070
Cooling Mode				
Minimum Load Water Flow (gpm)	23	34	54	78
Maximum Load Water Flow (gpm)	113	164	265	379
Minimum Leaving Chilled Water Temperature (No Glycol)(°F)	40	40	40	40
Minimum Leaving Chilled Water Temperature (with Glycol)(°F)	20	20	20	20
Minimum Chilled Water Differential Temperature (°F)	4.5	4.5	4.5	4.5
Maximum Chilled Water Differential Temperature (°F)	20	20	20	20
Minimum Entering Source Air Temperature (°F)	0	0	0	0
Maximum Entering Source Air Temperature (°F)	115	115	115	115
Heating Mode				
Minimum Load Water Flow (gpm)	23	34	54	78
Maximum Load Water Flow (gpm)	113	164	265	379
Minimum Leaving Hot Water Temperature (°F)	75	75	75	75
Maximum Leaving Hot Water Temperature (°F)	135	135	135	135
Minimum Hot Water Differential Temperature (°F)	4.5	4.5	4.5	4.5
Maximum Hot Water Differential Temperature (°F)	30	30	30	30
Minimum Entering Source Air Temperature (°F)	10	10	10	10
Maximum Entering Source Air Temperature (°F)	60	60	60	60

Note:

1. Operating in ambient temperatures below 40°F requires a suitable antifreeze solution.
2. Contact factory for operations outside of recommended limits.

Pre-Startup

All startups must be performed by ClimaCool factory trained personnel. Prior to chiller startup, there are certain essential checks which must be completed. Failure to carry out these checks could result in damage to the chiller voiding the modules warranty.

Electrical

It is imperative to turn off the main electrical power supply and follow proper lock-out/tag-out procedures prior to servicing any of the chiller's electrical components. The following procedures can be performed only after the electrical power is confirmed to be off:

1. The installation must be inspected and approved by the respective agent and be in compliance with all local and national electrical codes.
2. **Check and tighten as required all electrical terminal connections on each module.** Utilize any lock-out/tag-out procedures required for your project location when performing this operation. If no procedure exists take all precautions necessary to prevent the power from being turned on. **A systematic tightening of all terminals inside the electrical control panel on each module should be carried out. This will include the compressor motor terminals, which would require removal of the compressor terminal cover.** Check connections at each safety and every termination in the panel.
3. Verify that a separate 115 volt power supply is used to power the CoolLogic Master Control Panel. Field connections are simplified requiring only a two conductor shielded cable daisy chain from the Master Controller to the modules. These control wires should be two-conductor shielded having #18 AWG minimum up to 50 feet, #16 AWG minimum up to 100 feet, rated at 60°C minimum. All field wiring must be identified (tagged).
4. All field connections should be checked for tightness.
5. Check all fuses for proper sizing as indicated on the chiller data plate and/or the electrical diagram on the inside door of the electrical panel.
6. Verify proper operation of the **mandatory** field installed pressure differential flow sensor.
7. On 208/230V units, confirm transformer(s) are properly tapped for the measured incoming power supply.
8. Verify proper installation of the mandatory factory provided field installed voltage/phase monitor.
9. **Confirm all panels and electrical covers are properly installed/sealed, including the condenser fan motor cover.**

Refrigeration



1. Refrigerant piping and components should be inspected for damage.
2. Place refrigerant gauges on the discharge and suction access ports of each refrigerant circuit to ensure a refrigerant charge is present. Leave the gauges on for

compressor rotation check.

3. Confirm the settings on all pressure switches.

Water System

1. Confirm that leak testing has been carried out.
2. Confirm that the system is clean.
3. Confirm that necessary water treatment systems are in place with the evaporator water systems.
4. Confirm the chilled water circulating pumps are operational and water is flowing through the exchanger.
5. Shut the entering water valve and blow out some water to check for particles or coloration from suspended particles. Record the pressure differential across the chiller heat exchanger measured at the pete's ports at each module.
6. Confirm correct water flow rates through the evaporator. Acquire the design parameters for the chiller bank from the ClimaCool Selection Program data (available from your local representative). Compare the measured differential pressures from step 5 above with the predicted flow rates to ensure proper correlation to the flow results.
7. Verify proper installation of the mandatory factory provided field installed pressure differential flow sensor, temperature sensors and wells (**sensors should be fully inserted in the well**) and verify calibration of sensors read through CoolLogic Control System.
8. Confirm installation of the **mandatory field installed chilled water strainer with minimum of 60 mesh screen.**

⚠ WARNING/AVERTISSEMENT	
<p>Disconnect power supply (ies) before servicing. Refer servicing to qualified service personnel. Electric shock hazard. May result in injury or death!</p>	 <p>Débrancher avant d'entreprendre le dépannage de l'appareil. Consulter un réparateur qualifié pour le dépannage. Risque de choc électrique. Résultat de mal dans dommages ou la mort!</p>
⚠ CAUTION/ATTENTION	
<p>Unit to be serviced by qualified personnel only. Refrigerant system under pressure. Relieve pressure before using torch. Recover refrigerant and store or dispose of properly.</p>	 <p>Confier la maintenance à un technicien qualifié. Le système frigorifique sous pression. Décompresser avant d'exposer à la flamme. Récupérer le frigorigène et le stocker ou le détruire correctement.</p>

⚠ CAUTION/ATTENTION	
3 PHASE SCROLL COMPRESSOR UNITS	UNITÉ DE COMPRESSEUR SCROLL 3-PHASE
<p>If this unit uses a 3 Phase Scroll Compressor, the following instructions MUST BE followed:</p> <ul style="list-style-type: none"> • Unit power supply MUST BE wired in the proper sequence to avoid damage to the 3 Phase Scroll Compressor; • Scroll Compressors with INCORRECT rotation show the following characteristics: <ul style="list-style-type: none"> - High sound level; - Low suction pressure and low discharge pressure; - Low current draw. • If any of the three above characteristics exist, swap two of the three supply wires at the disconnect and recheck compressor for incorrect rotation. 	<p>Si cet appareil utilise compresseur scroll 3-Phase, les instructions suivantes doivent être suivies:</p> <ul style="list-style-type: none"> • L'alimentation de l'appareil doit être monté dans l'ordre correct pour éviter endommager le compresseur scroll 3-Phase • Compresseurs scroll avec rotation incorrecte montrent les caractéristiques suivantes: <ul style="list-style-type: none"> - Haut niveau de son; - Pression d'aspiration élevée et une faible pression de décharge; - Faible ampérage • Si l'un des trois éléments mentionnés ci-dessus sont remplies, échanger deux des trois lignes électriques alimentant l'interrupteur de sécurité et vérifier la rotation du compresseur.

Project Name:	Date:
Address/Phone:	

- | | YES | NO |
|---|--------------------------|--------------------------|
| 1. Are modules connected properly per Codes and Installation Manual?
(Installation, Operation & Maintenance (IOM) Manual is available at www.climacoolcorp.com). | <input type="checkbox"/> | <input type="checkbox"/> |
| 2. Is there a 60 mesh strainer on the inlet water of each loop? (4 pipe SHC has two (2) loops)
(Fill water to chiller being sure to pass through a minimum of 60 mesh strainer). | <input type="checkbox"/> | <input type="checkbox"/> |
| 3. Is chilled water system filled, flushed and all air purged from system?
(All air must be purged from system prior to startup. See "Filling the Water System" in IOM). | <input type="checkbox"/> | <input type="checkbox"/> |
| 4. Are all pumps tested and operational? | <input type="checkbox"/> | <input type="checkbox"/> |
| 5. Are required GPM's (verified by pressure differential) supplied to the chilled water side?
(See project specifications or selection and performance sheets available from ClimaCool Sales Rep) | <input type="checkbox"/> | <input type="checkbox"/> |
| 6. Are the pressure differential flow sensors properly installed and wired to the CoolLogic controller? | <input type="checkbox"/> | <input type="checkbox"/> |
| 7. Have all chiller coupling connections been leak tested? | <input type="checkbox"/> | <input type="checkbox"/> |
| 8. Is water presently circulating through chiller? | <input type="checkbox"/> | <input type="checkbox"/> |
| 9. Verified that temperature sensors and voltage/phase monitor have been installed? | <input type="checkbox"/> | <input type="checkbox"/> |
| 10. Verified power supply agrees with chiller nameplate? | <input type="checkbox"/> | <input type="checkbox"/> |
| 11. Is power and communication wiring complete to each module? | <input type="checkbox"/> | <input type="checkbox"/> |
| 12. Verified that wiring and devices meet with approved electrical submittal drawings? | <input type="checkbox"/> | <input type="checkbox"/> |
| 13. Is required load available to run multiple compressors at start-up? | <input type="checkbox"/> | <input type="checkbox"/> |
| 14. Is a water header bypass installed at the chiller? <input type="checkbox"/> ClimaCool provided? <input type="checkbox"/> Field provided? (Check one) | <input type="checkbox"/> | <input type="checkbox"/> |
| 15. Are all panels and electrical covers properly installed/sealed, including condenser fan motor covers? | <input type="checkbox"/> | <input type="checkbox"/> |

If you checked "No" to any question above, provide the line reference number and the date of scheduled completion below. Please note **all conditions must be complete prior to the start-up date.**

*This form must be completed and submitted to ClimaCool Corp. **three (3) weeks** prior to final scheduling of any Start-up.
Note: If any of the above items are not complete at time of start-up, backcharges will be assessed for additional costs.

Contractor Name:	
<hr/>	
Address:	
<hr/>	
(Authorized Signature)	
<hr/>	
Phone:	Date:
<hr/>	

Startup

All startups must be performed by ClimaCool factory trained personnel.

1. Review all items are complete from the Pre Startup Checklist.
2. Cross reference model number with submittal sheet to verify that the units are the correct model type and voltage requirements.
3. Verify the location and wiring connections of all main header temperature sensors (should be a minimum of 36" but no more than 60" from the bank). Confirm that all sensors are **FULLY INSERTED** into their sensor wells and wired back to the correct terminals in the Master Control Panel.
4. **Confirm all panels and electrical covers are properly installed/sealed, including the condenser fan motor cover.**
5. Verify the location and ports for all water differential pressure sensors used for flow detection ((+) port piped to the inlet headers and the (-) ports piped to the outlet headers).
 - Verify the correct wiring using the +5VDC power supply to the differential sensor inputs.
 - Verify the correct output wiring from the differential sensors back to the master controller universal input (UI) channels 8 and 11. Confirm inputs 8 and 11 jumpers are set to 'volts'. **Note:** The differential sensor ports should **NOT** be piped to a location which includes strainer pressure drops.
6. Verify that evaporator header inlets (hot water side if simultaneous application) include strainer assemblies equipped with 60 mesh screens.
7. Inspect all refrigerant piping for oil leaks which may have occurred during shipment which might indicate a refrigerant leak. Check the high pressure cutout setting of the pressure controls. The setting should be 585 psig for all UCA models.
8. Verify the location and settings of the phase loss monitor. It should be in a location to sense the voltage condition in the main, high voltage panel which feeds high voltage to each module independently. (See Electrical Connections on page 15). Verify the low voltage output wiring from the phase loss monitor (terminals 4 and 5) back to the main CoolLogic controller, input channel 12.
9. Verify motorized water isolation valves auxiliary switch dial settings, to ensure they close near:
 - 30% for evaporator/chilled water valves for cooling only units and hot water/condenser valves for Simultaneous Heating and Cooling units
10. Confirm that the main water pumps are driven by VFD's, and that all VFD's are controlling the pump speeds to produce a nominal differential pressure drop across the chiller bank headers, measured precisely at the differential pressure sensor locations in step 4 above.

Nominal differential pressure ranges are from 3 to 10 psid.
11. Confirm the jumper locations for all master controller and module controllers as shown on the wiring diagrams provided on the inside electrical door panels.
 - Set the rotary switches for the MAC Address of the master controller to be "01."
 - Set the rotary switches for the module controllers to be "02" for module #1, "03" for module #2, and so on.
12. Tighten every screw and lug connection inside the CoolLogic master control panel and inside each module control panel high voltage section. Check auxiliary contacts on contactors and ensure #1 auxiliary is wired on the #1 contactor. Open up the compressor junction box located on the front of each compressor and verify main electrical terminal lug tightness and the low voltage wires on protection module.
13. Verify the communication cable wiring to ensure it is 18 AWG, simple two conductor shielded cable and that the wiring is alone inside solid conduit between the master control panel and the first module control panel. Verify the cable's outer jacket is not stripped more than one inch. If so, the wires may have become untwisted, causing signal reflections. Confirm the wires are connected correctly to the terminal blocks at the master and each module as follows:
 - Black wire to **Net-**
 - White wire to **Net +**
 - Shield wire to **Shield**
14. Power-up the master control panel and download the appropriate clipping file into the master controller, following instructions.
15. Power up each module control panel, turn OFF the two toggle switches located on the inside bottom of the low voltage side of the module electrical panel. Download the appropriate clipping file into the module controllers, following the instructions.
16. Check for proper line or high voltage values at each module input power block, and the 24 VAC low voltage values for correctness (+/- 10% of nominal values).
17. On 208/230V units, confirm transformer(s) are properly tapped for the measured incoming power supply.

Startup

18. Use refrigerant gauge set suitable for the high pressure R-410A, and hook up to the suction and discharge ports of each module's compressor stages separately. Bump start the compressors either by depressing the contactor manually, or by using the manual run commands from the Master Control Panel, (found in the FN 7, or the service menu). Bump the compressor only for 1-2 seconds to ensure the correct rotation of the scroll compressors (indicated by a rising highside pressure and a falling suction pressure).
19. Verify proper communications from each module back to the master controller using the "STATUS" menu, then indexing down to the desired compressor data screen.
 - If the compressor data parameters all read "o", then communications are not yet established, and communications cable troubleshooting is required.
 - When all compressor data parameters read actual values which agree with the refrigerant gauge set and refrigerant line temperatures, then it is safe to assume that communications are established.
20. Set up the master controller parameters according to the specific job submittal sheets.
 - All parameters can be found in the FN 2 menu (setup), FN 6 menu (module factory settings), FN 7 menu (service), FN 8 menu (master factory settings).
 - It is imperative to access EVERY MENU and EVERY PARAMETER to ensure all settings are appropriate.
21. Set up the Building Automation System (BAS) interface parameters (as required) using the FN 0 menu (network number selection, IP addressing), FN 4 menu (device instances).

Adjusting Unit Charge and Thermal Expansion Valves Using Subcooling and Superheat Method

Due to varying installation conditions/applications and to optimize performance, proper refrigerant charge and thermal expansion valve (TXV) adjustment must be confirmed.

After checking compressor rotation, choose a circuit to be tested first. Connect test equipment to monitor the suction line and liquid line temperatures simultaneously. Place a manifold gauge set on the suction line and liquid line then start the compressor. As long as the suction pressure is high enough to prevent the low pressure switch from tripping, run the compressor for five minutes.

Verify proper subcooling. This is accomplished by subtracting the liquid line temperature from the saturated condensing temperature. The saturated condensing temperature is found by converting the liquid line pressure reading on the manifold gauge to the related temperature. The normal subcooling temperature range at the condenser

is 5-15°F, BUT for total accuracy please follow the charge recommendations found in the selection program. If subcooling is too low, then refrigerant must be added to the system. Add charge and wait five minutes before checking results. If subcooling is too high, then refrigerant must be removed from the system.

Verify proper superheat by subtracting the saturated evaporative temperature from the suction line temperature. The saturated evaporative temperature is found by converting the suction pressure reading on the manifold gauge to the related temperature. The proper superheat temperature range is 6-18°F at normal operating conditions (typically 44° leaving chilled water temperature). If superheat is low, this may indicate that the expansion valve is overfeeding. To adjust the expansion valves, turn the adjustment stem clockwise. This will cause the superheat to rise. Wait five minutes before checking the results of this adjustment. Repeat until the desired superheat is achieved.

Once adjusted, also check the discharge gas superheat (DGSH) to confirm reading is not less than 50°F degrees and the discharge line temperature is not more than 220°F degrees. To check discharge gas superheat, first obtain the saturated condensing temperature by converting the discharge pressure to saturated refrigerant temperature using a pressure temperature chart. Next, measure the discharge line temperature 6 to 10 inches from the compressor. Subtract the saturated condensing temperature from the discharge line temperature to find the discharge gas superheat. If the DGSH is below 50°F degrees, liquid refrigerant is still present in the suction gas vapor returning to the compressor. The TXV will require additional clockwise adjustment to raise the discharge gas superheat into the acceptable range.

Superheat & Subcooling Flow Chart

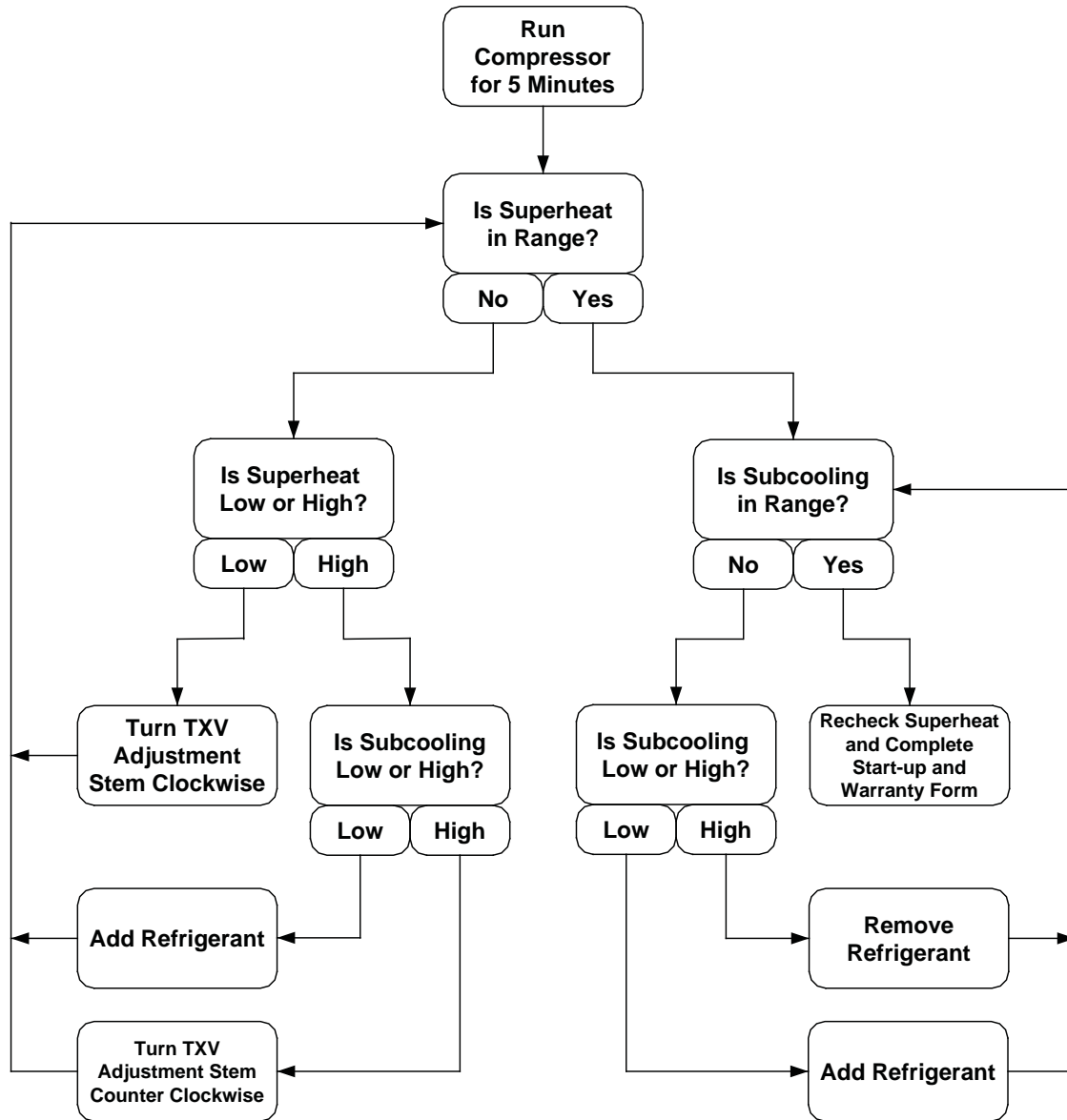

Caution: Do not charge to achieve subcooling temperature when the expansion valve is overfeeding. If the expansion valve is overfeeding, readings may still indicate low subcooling and low superheat, but circuit may not be undercharged.

Startup Documentation

All startup paperwork and documentation must be submitted to ClimaCool. Future warranty claims cannot be processed without a completed Startup and Warranty Registration form on file (See page 33 for Startup and Warranty Registration Form and page 89 for Warranty).

Water Testing

Extract three (3) water samples from each water side, evaporator/chilled for a cooling only application or evaporator/chilled and hot water/condenser for Simultaneous Heating and Cooling application using the bottles provided (three bags; each bag containing three bottles) from the Water Sample test kit. Confirm that the sample bottles are filled to the top leaving no air in the bottles. All the sample bottles must have labels completed per instructions included with the bottles. Ship the bottles immediately to the appropriate water testing laboratory per the instructions.

Startup and Warranty Registration Form (Pkg Air-Cooled UCA)

Sign, date and E-mail to: technicalsupport@climacoolcorp.com or
 Fax: 405.815.3052 Attn: Technical Support

Ambient Temp: _____ Page: 1 of 1

Project Name: _____
 Address: _____
 City/State/Zip: _____
 Startup Date: _____

Contractor Name: _____
 Address: _____
 City/State/Zip: _____
 Phone No.: _____

Module

Model No.: _____
 Serial No.: _____
 Chiller No.: _____ Bank No.: _____

Compressor

Model No.: _____
 Serial No. 1: _____
 Serial No. 2: _____

Bank Water Pressures Entering / Leaving

Evaporator: _____ / _____ Δ P _____
 "Flow devices" shut of chiller below 40% of flow for Cool loop & 25% for Heat loop: (if used) Yes

Water Samples Taken (Mark "X")

Evaporator: Yes N/A
 Yes

**For initial MANDATORY water samples, bottles are provided.
 Follow instructions on label and mail the same day sample is taken.**

► **All wiring terminations** in module panel, safeties and compressors tightened: Yes No

Voltage / Ground

L1 _____ L2 _____ L3 _____
 Low Voltage (24V): _____

Phase / Phase

Voltage: L1/L2 _____ L2/L3 _____ L1/L3 _____
 Fan Amps: L1 _____ L2 _____ L3 _____

Compressor Circuit #1

Amperage: L1 _____ L2 _____ L3 _____
 Sight Glass Oil Level: _____
 Suction Pressure (psig): _____
 Suction Temperature (F): _____
 Compressor Superheat (F): _____
 Discharge Pressure (psig): _____
 Discharge Temperature (F): 220° max _____
 Discharge Gas Superheat (F): 50° min _____
 Condenser Liquid Line Temperature (F): _____
 Condenser Liquid Subcooling Temp. (F): _____
 Evaporator Entering Water Temperature (F): _____
 Evaporator Leaving Water Temperature (F): _____
 Condenser Entering Air Temperature (F): _____
 Condenser Leaving Air Temperature (F): _____
 Evaporator Pressure Differential (psig): _____

Compressor Circuit #2

Amperage: L1 _____ L2 _____ L3 _____
 Sight Glass Oil Level: _____
 Suction Pressure (psig): _____
 Suction Temperature (F): _____
 Compressor Superheat (F): _____
 Discharge Pressure (psig): _____
 Discharge Temperature (F): 220° max _____
 Discharge Gas Superheat (F): 50° min _____
 Condenser Liquid Line Temperature (F): _____
 Condenser Liquid Subcooling Temp. (F): _____
 Evaporator Entering Water Temperature (F): _____
 Evaporator Leaving Water Temperature (F): _____
 Condenser Entering Air Temperature (F): _____
 Condenser Leaving Air Temperature (F): _____
 Evaporator Pressure Differential (psig): _____

Software Version: _____

► **Verify Safety Setting Limits:**

Low Temp: <input type="checkbox"/>	High Pressure: <input type="checkbox"/>	Low Pressure: <input type="checkbox"/>
------------------------------------	---	--

► **Verify Safety Setting Limits:**

Low Temp: <input type="checkbox"/>	High Pressure: <input type="checkbox"/>	Low Pressure: <input type="checkbox"/>
------------------------------------	---	--

Are all panels and electrical covers properly installed/sealed, including condenser fan motor covers?

Rep Signature: _____ Print Name: _____
 E-Signature: Check Box (Authorized Signature)

Doc: Pkg AirCooledStartupWarranty UCA
 SD #0014 Rev. 4.15.15

Operation and Maintenance

Pressure and Temperature Log

A log of temperatures and pressures should be taken regularly. Periodically conduct a visual inspection of the chiller to identify problems before they reach the point of failure. As with any mechanical system, it is necessary to conduct a series of checks to the ClimaCool chiller to confirm correct operation.

Maintaining a Daily Log

Date							
Chiller No.							
Technician							
	Sun.	Mon.	Tue.	Wed.	Thur.	Fri.	Sat.
Chiller Water Entering Temperature							
Chilled Water Leaving Temperature							
Chilled Water Pressure Drop							
Faults: Note By Module Number							

Daily

- A daily operational log should be kept.
- Perform visual inspection.
- Record entering and leaving chiller water temperatures and pressures.
- Note any problems that may exist and immediately plan for further investigation. If repair is necessary, schedule for earliest possible date.
- Properly document all data taken.

Weekly

- Review daily log from previous week.
- Perform visual inspection.
- Properly document all data taken.
- Note any problems that may exist. Immediately plan for further investigation. If repair is necessary, schedule for earliest possible date.

Quarterly

Check controller operating parameters and setpoints.

- Check temperature drop/rise on heat exchanger. *
- Check compressor oil level.
- Check compressor oil color.
- Check water flow rates and pressure drops across evaporator heat exchanger.
- Clean condenser coil with vacuum and soft brush (to protect coil fins) and to prevent dirt accumulation.
- Check all electrical connections for tightness.
- Properly document all data taken.

* The temperature drop/rise on a fully loaded (both compressors) heat exchanger is generally 10°F. If only one compressor is running the temperature drop/rise will be approximately 5°F. Some projects

are designed to have a higher or lower temperature drop on the evaporator depending on application. Consult the bank performance sheet for your specific project for these values. If the temperature drop/rise is greater than the design, your heat exchanger may need to be back flushed or the strainer may need to be cleaned.

Visually inspect inner and outer condenser coil slab and remove surface loaded fibers as needed. Use a vacuum cleaner. If a vacuum cleaner is not available, a soft non metallic brush may be used. In either case, brush in the direct of the fin as they can be easily bent over and damaged.

A periodic clean water rinse is very beneficial for coils applied in coastal or industrial environments. It is very important the water rinse is made with a low velocity stream to avoid damage to the coil fins. Use only environmentally sound coil cleaners. Avoid the use of: Coil brighteners, high pressure washers and poor water quality for cleaning.

Annual

- Back flush all heat exchangers. If fouling is suspected, use only ClimaCool recommended de-scalers (see page 36 - Chemical Clean In Place Washing).
- Remove and clean all waterside strainers.
- Manually operate all waterside isolation valves, if provided, on each module.
- Check all electrical connections for tightness.
- Perform leak check on all refrigerant circuits.
- Check all header piping couplings for tightness.
- Check oil level and color on each compressor.
- Check and test all refrigerant safeties for proper operation.
- Check all peripheral systems for proper operation.
- Check and test CoolLogic Control System.
- Verify setpoints, sensors and general control configuration.
- Properly document all data taken.

⚠ WARNING/AVERTISSEMENT	
Very Hot Water!	L'eau Très Chaude!
	
WATER AND REFRIGERANT SYSTEMS UNDER PRESSURE	EAU ET FRIGORIGÈNE EQUIPEMENTS SOUS PRESSION
<ul style="list-style-type: none"> • Isolate/Lockout source and relieve pressure BEFORE servicing equipment. • Failure to relieve pressure may result in property damage, serious bodily injury or death! 	<ul style="list-style-type: none"> • Isoler la source / de verrouillage et de soulager la pression avant entretien de l'équipement. • Le défaut de soulager la pression peut entraîner des dommages matériels, des blessures corporelles graves ou la mort!

Condenser Fans

Highly efficient, variable speed EC condenser fans with integral head pressure control are provided as standard. Fans include electronically switched external rotor motors with permanent magnets and a speed that is controlled by an integrated controller. Fan speed is controlled by a 0-10 VDC signal.

The integrated variable speed drives are equipped with a solid state motor overload protection and a solid state short circuit protection. The solid state motor overload protection protects the motor under overload conditions by reducing current flow to the internal motor output terminals. The overload protection circuitry is optimally configured to the specific motor and the specific final application of the integrated variable speed drive.

Figure 25 - Condenser Fan



- Check the impeller, in particular the weld-seams, for possible cracks. Any repairs by welding is prohibited.
- The fan or motor is maintenance free due to the use of ball bearings with “life-long lubrication”. At the end of the grease service life (ca. 30-40,000 h during standard usage) it is necessary to change the bearing.
- Regular inspection, and cleaning is necessary to prevent imbalance due to ingress of dirt.

Cleaning

The use of paint solvents, abrasive and/or aggressive cleaners are prohibited.

Cleaning with a Water Jet:

- Make sure that water does not get inside the motor and electronics.
- Do not hold the jet spray directly on the motor openings and seals.
- Warranty does not cover corrosion formation, paint adhesion for unpainted or painted fans if cleaning with a jet spray.
- After the cleaning process, the fan must be operated for 30 minutes at 80 – 100% of maximum speed for drying purposes.

Attention: Confirm all panels and electrical covers are properly installed/sealed, including the condenser fan motor cover.

Repairs and Maintenance

- Allow maintenance work to be carried out by trained specialists only.
- Please observe the safety regulations and the worker’s protection rules by all maintenance and service work (DIN EN 50 110, IEC 364).
- The fan must be disconnected from the power supply and secured against switching back on prior to maintenance.
- Keep the airways of the fan free.
- Depending on the application and the transfer medium the impeller has a natural wear. Deposits on the impeller can lead to imbalance, fracture, damage or disintegration. Proper maintenance must be provided.
- In case of imbalance, rebalance the impeller.

Heat Exchangers

Draining

When performing standard maintenance procedures such as flushing a heat exchanger, it will be necessary to close off a section of a module. This can easily be done if factory mounted water isolation valves are provided. Access to a floor drain is helpful when performing standard maintenance procedures.

Back Washing

It may become evident from the recorded weekly log data that the performance of the chiller is gradually degrading. This could be due to a buildup of debris or sludge obstructing the free passage of flow through the heat exchangers. This debris can be removed by a back washing process which involves the introduction of a forced violent backwards flow through the heat exchanger using a carefully formulated flushing solution. To be effective, this back flow should be slightly higher than the normal flow, and in the opposite direction. The difficulties and practicality of this method depends on the back wash pumping system itself. Another method is to back flush each heat exchanger using city water as opposed to system water (see Figure 25 on page 36 – City Water Cleaning Arrangement). The back washing procedure is accomplished by isolating each individual heat exchanger and introducing the city water using a connection hose to the 3/4” service port to flow in an opposite direction from the normal heat exchanger flow direction. On the opposite 3/4” service port, connect a drain hose continuing back flow until all debris is removed. **Warning: Water valves must be re-opened after flushing is complete.**

Chemical Clean In Place Washing Without Water Isolation Valves

Chemical Clean in place washing will typically provide the best debris removal, even from severely clogged heat exchangers. In order to clean the heat exchangers for modules **WITHOUT** water isolation valves, it will be necessary to mechanically and electrically isolate each module separately from the bank of modules. The rest of the chiller modules will need to be disabled during this cleaning procedure as the flow through the main bank header will be interrupted. The cleaning tank, pump and pump strainer should be arranged in the manner shown in Figure 26 on page 36 - In Place Cleaning Arrangement. The flow of the cleaning is arranged in the opposite flow to the normal operational direction. Connection points are provided using the 3/4” service ports at each heat exchanger. The cleaning solution used can be either a detergent or hot water to remove particles and simple cleaning. If correct water treatment has been implemented, this should provide adequate cleaning for most situations. The solution can be pumped through the heat exchangers and allowed to “soak” for a time and then pumped again. Upon successful cleaning

of a module, proceed to isolate a second module separately from the bank and repeat the cleaning process.

Chemical Clean In Place Washing With Water Isolation Valves

Chemical Clean in place washing will typically provide the best debris removal, even from severely clogged heat exchangers. It is only necessary to mechanically and electrically isolate one chiller module at a time. The rest of the chiller modules can continue to operate to satisfy the cooling load required. The cleaning tank, pump and pump strainer should be arranged in the manner shown in Figure 26 on page 36- In Place Cleaning Arrangement. The flow of the cleaning is arranged in the opposite flow to the normal operational direction. Connection points are provided using the 3/4” service ports at each heat exchanger. The cleaning solution used can be either a detergent or hot water to remove particles and simple cleaning. If correct water treatment has been implemented, this should provide adequate cleaning for most situations. The solution can be pumped through the heat exchangers and allowed to “soak” for a time and then pumped again.

If it is required to remove carbonates, then an acidic wash is recommended. A 2% solution of phosphoric or sulfamic acids in pure water are generally acceptable. These acid solutions should only be allowed to circulate within the heat exchanger for 10 to 15 minutes, followed by a thorough pure water flush for 10 to 15 minutes. **Hydrochloric or sulfuric acids must not be used.** In any case, consult the chemical supplier to establish the correct formulation and handling process. The materials, which will be exposed to the wash, are stated on page 23 – Water Treatment.

Once the washing is complete, the solution should be flushed out completely by pumping clean, fresh water through the chiller. To achieve a reasonable level of dilution, it may be required to change the water several times. After cleaning, the water quality and water treatment should be confirmed.

Cleaning Arrangement

Figure 26 - City Water Cleaning Arrangement

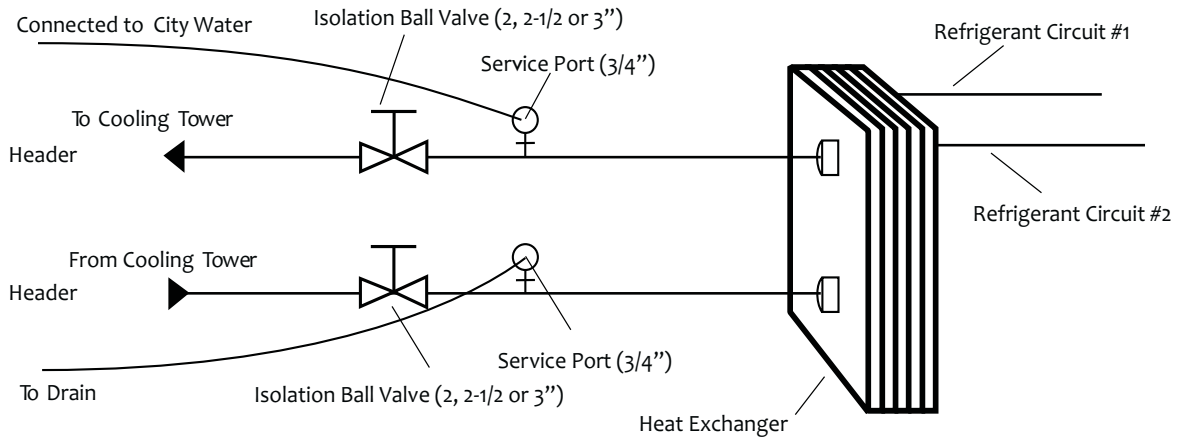
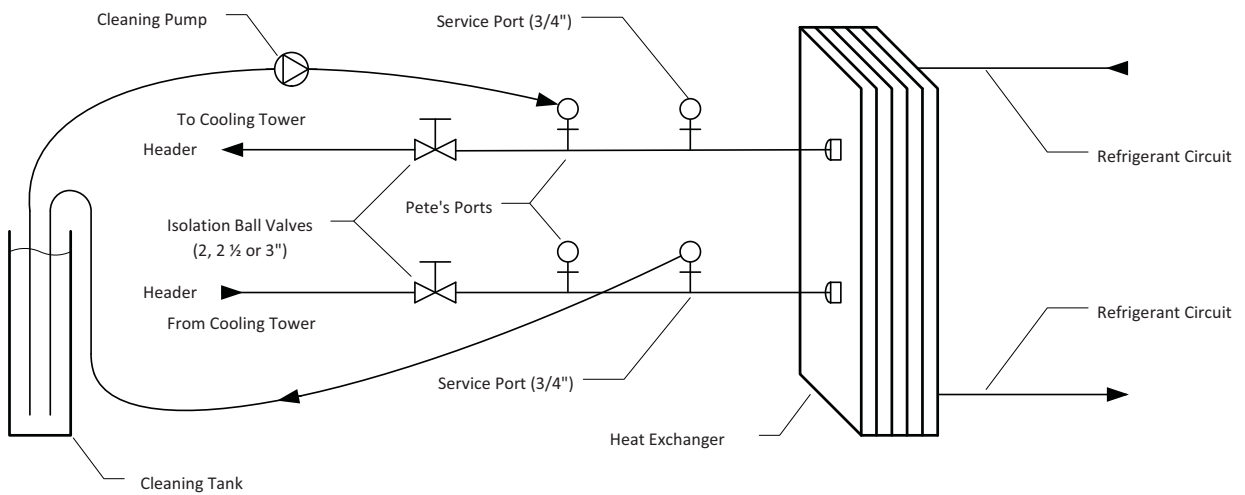

Figure 27 - In Place Cleaning Arrangement



Notes:

1. When backwashing, be sure to flush in opposite direction of flow.
2. Be sure to open all manual valves before unit is put back into operation.

Compressor Information

Highly efficient and extremely reliable scroll compressors are used on Model UCA. The information contained in this manual will be useful for their care.

Compressor Rotation

All scroll-type machines are unidirectional and will only compress in one direction. Operating in the reverse rotation can be destructive and will be indicated by a loud operating noise together with a lack of compression.

Compressor Anti-Short Cycle Timer

Built into the logic of the CoolLogic Control System is an anti-short cycle timer which will prevent the compressors from restarting immediately following a compressor shutdown. Minimum on 75 seconds and minimum off 200 seconds.

Compressor Crankcase Heater

A crankcase heater is factory installed to prevent refrigerant migration, condensation and mixing with the compressor oil during the off cycle.

Compressor Lubrication

The compressor operates on a sealed system and oil can only be lost if leak occurs. There are few cases when oil will need to be added to a machine in normal operation.

Oil Type

The oil in scroll compressors will be either Polyolester type oil (POE) or polyvinyl-ether type oil (PVE). Both refrigerant oils require special handling and should be protected from contamination. They are extremely hygroscopic and will absorb moisture rapidly from the air. It is strongly recommended to store and dispense both oils from sealed metal cans. **Note: Refer to compressor name plate for proper oil type. Different oils cannot be mixed.**

Oil Levels

The oil level in the compressor should be checked with the compressor running. The compressor oil level may vary during operation and particularly on the startup. The normal operating compressor oil level should be between 1/3 and 1/2 of the sight glass. During operation, a certain amount of oil is carried out into the refrigerant system. The system has been designed to bring the oil back to the compressor. If the level in the sight glass falls, it may be due to the operating conditions and enough time should be given to allow the oil to return before more oil is added. This could take up to six hours of operation. The compressor should not be allowed to operate with less than 1/8 of the sight glass for longer than four to six hours.

Adding Oil

The compressor must never be ran in a vacuum. A suitable hydraulic pump should be used to add oil and reserved for this process. **It is imperative that oil type be verified prior to adding to a compressor.** Oil should only be added to a compressor while it is operating to observe valid oil sight glass levels. Oil is pressure-injected either into a gauge connection on the suction line or injected into the oil process port at the bottom of the compressor housing. Only enough oil should be added to raise the level above the 1/3 sight glass point.

⚠ CAUTION/ATTENTION	
3 PHASE SCROLL COMPRESSOR UNITS	UNITÉ DE COMPRESSEUR SCROLL 3-PHASE
<p>If this unit uses a 3 Phase Scroll Compressor, the following instructions MUST BE followed:</p> <ul style="list-style-type: none"> Unit power supply MUST BE wired in the proper sequence to avoid damage to the 3 Phase Scroll Compressor; Scroll Compressors with INCORRECT rotation show the following characteristics: <ul style="list-style-type: none"> High sound level; High suction pressure and low discharge pressure; Low current draw. If any of the three above characteristics exist, swap two of the three supply wires at the disconnect and recheck compressor for incorrect rotation. 	<p>Si cet appareil utilise compresseur scroll 3-Phase, les instructions suivantes doivent être suivies:</p> <ul style="list-style-type: none"> L'alimentation de l'appareil doit être monté dans l'ordre correct pour éviter endommager le compresseur scroll 3-Phase Compresseurs scroll avec rotation incorrecte montrent les caractéristiques suivantes: <ul style="list-style-type: none"> Haut niveau de son; Pression d'aspiration élevée et une faible pression de décharge; Faible ampérage Si l'un des trois éléments mentionnés ci-dessus sont remplis, échanger deux des trois lignes électriques alimentant l'interrupteur de sécurité et vérifier la rotation du compresseur.

ATTENTION
<p>To avoid the release of refrigerant into the atmosphere, the refrigerant circuit of this unit must be serviced only by technicians who meet local, state and federal proficiency requirements.</p> <p>All refrigerant discharged from this unit must be recovered WITHOUT EXCEPTION. Technicians must follow industry accepted guidelines and all local, state and federal statutes for the recovery and disposal of refrigerants.</p> <p>If a compressor is removed from the unit, system refrigerant circuit oil will remain in the compressor. To avoid leakage of compressor oil, the refrigerant lines of the compressor must be sealed after it is removed.</p>

Refrigeration Circuit Diagram, Cooling Only

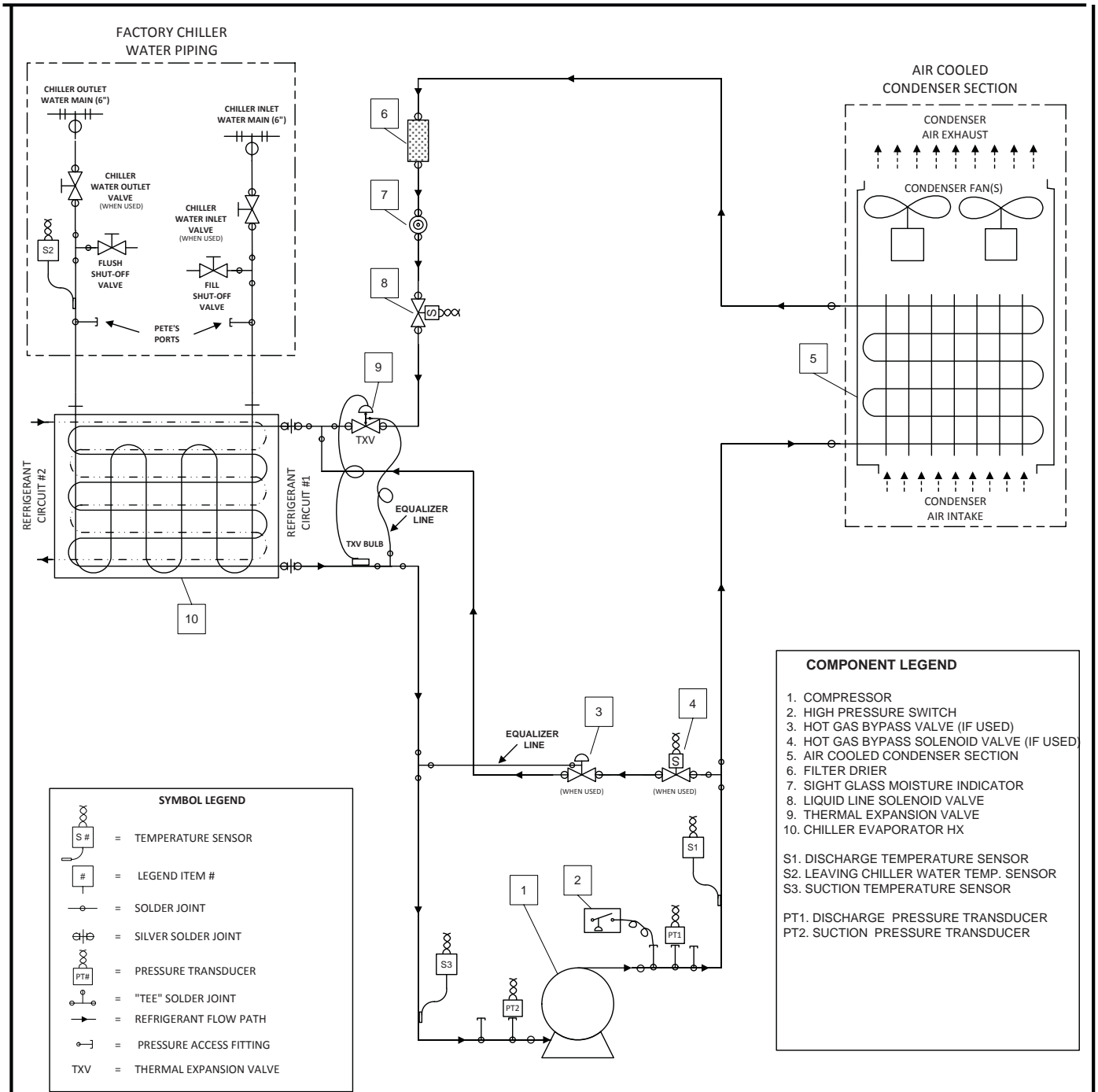

		TITLE REFRIGERATION CIRCUIT DIAGRAM (CIRCUIT #1 OF 2 SHOWN)			
		DESCRIPTION PACKAGE AIR-COOLED MODULAR CHILLER CLIMACOO Model # UCA020,030,070			
APPROVED	DATE	FILENAME	SIZE	DWG NO	REV
	04/12/2013	RefriDiag-UCA	A	RefriDiag-UCA	A
			SCALE	DRAWN BY	DATE
			NONE		04/12/2013
				SHEET	1 OF 1

Refrigeration Circuit Diagram, Cooling Only, -20°F Low Ambient

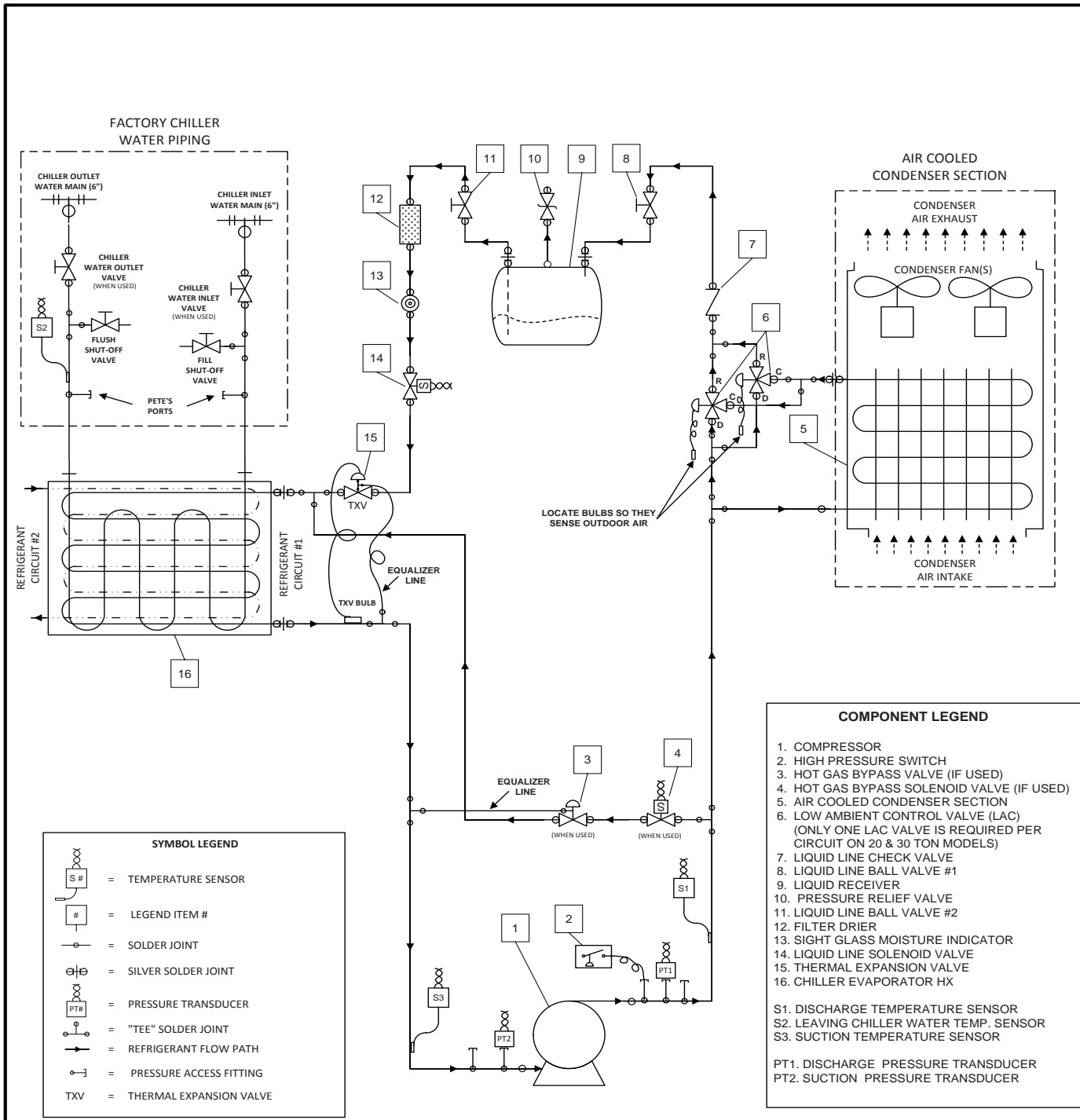

		TITLE		REFRIGERATION CIRCUIT DIAGRAM (CIRCUIT #1 OF 2 SHOWN)	
		DESCRIPTION		PACKAGE AIR-COOLED MODULAR CHILLER -20°F LOW AMBIENT CONTROL CLIMACOOL Model # UCA020,030,070	
APPROVED	DATE	FILENAME	SCALE	DRAWN BY	DATE
	03/14/2014	RefrDiag-UCA (-20°F Ambient)	NONE	Engineering	03/14/2014
REVISED			SIZE	DWG NO	REV
REVISED			A	RefrDiag-UCA (-20°F Ambient)	A
			SCALE	DWG NO	REV
			NONE	RefrDiag-UCA (-20°F Ambient)	A
			DRAWN BY	DATE	SHEET
			Engineering	03/14/2014	1 OF 1

Refrigeration Circuit Diagram, Heat Pump

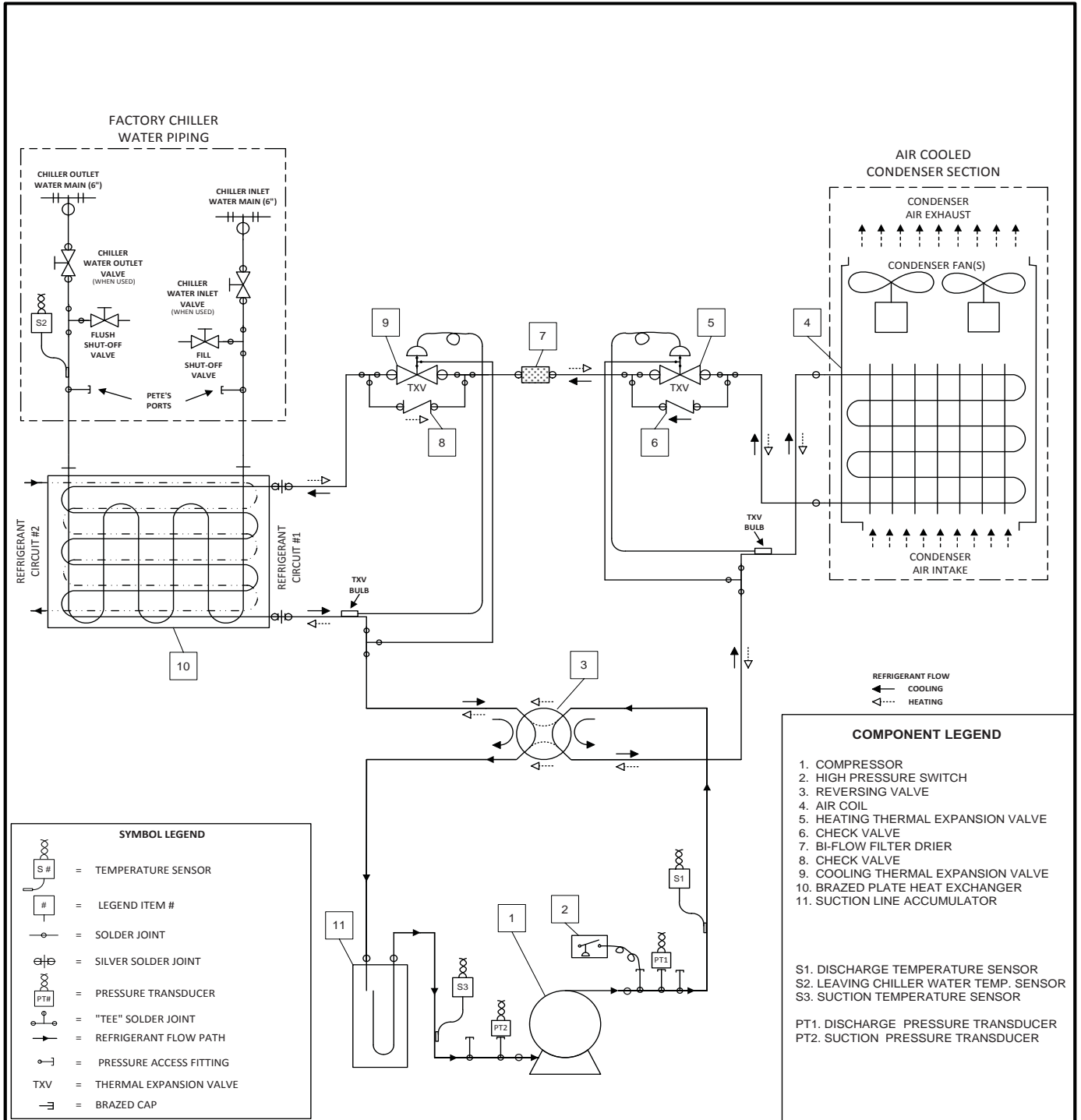

		TITLE REFRIGERATION CIRCUIT DIAGRAM (CIRCUIT #1 OF 2 SHOWN)			
		DESCRIPTION PACKAGE AIR-COOLED MODULAR HEAT PUMP CHILLER CLIMACOOL Model # UCA020,030,070			
APPROVED	DATE	FILENAME	SIZE	DWG NO	REV
	07/28/2014	RefrigDiag-UCA-HP	A	RefrigDiag-UCA-HP	F
SCALE		DRAWN BY		DATE	
NONE		Engineering		07/28/2014	
SHEET			1 OF 1		

Head Pressure Control Valve Operation (LAC)

High and Low Ambient Stability

The design of air conditioning systems, utilizing air cooled condensing units, involves two main problems that must be solved if the system is to operate reliably and economically during **high ambient** and **low ambient** operation. If the condensing unit is properly sized, it will operate satisfactorily during extremely high ambient temperatures. However, some units will be required to operate at ambient temperatures below their design dry bulb temperature during most of the year; the solution to low ambient operation is more complex.

Without good head pressure control during low ambient operation, the system can experience both running cycle and off-cycle problems. Since the pressure differential across the thermostatic expansion valve port affects the rate of refrigerant flow, low head pressure generally causes insufficient refrigerant to be fed to the evaporator. Failure to have sufficient head pressure will result in low suction pressure and/or iced evaporator coils. The primary off-cycle problem is refrigerant migration to the condenser. Insufficient flow through the TXV will cause a low suction pressure.

The typical method of maintaining normal head pressure in a refrigeration system during periods of low ambient temperature is to restrict liquid flow from the condenser to the receiver, and at the same time divert hot gas to the inlet of the receiver. This backs liquid refrigerant up into the condenser reducing its capacity which in turn increases the condensing pressure. At the same time the hot gas raises liquid pressure in the receiver, allowing the system to operate normally.

LAC-10 Valve Operation

The valve designation LAC stands for **Low Ambient Control**. The LAC is a three-way modulating valve that responds to receiver pressure. As shown in Figure 28, the receiver pressure acts under the diaphragm. As the receiver pressure drops below the valve setting, the seat moves away from the discharge port allowing discharge gas to bypass the condenser. This discharge gas warms the liquid in the receiver and raises the pressure to the valve setting. At the same time discharge gas is bypassing the condenser, liquid flow from the condenser is restricted, which allows liquid to back up in the condenser. Flooding the condenser reduces the area available for condensing thus raising the condensing pressure. During summer conditions, the seat closes the discharge port due to high pressure in the receiver. Therefore, there is full liquid flow from the condenser to the receiver.

Figure 28 - LAC-10 Valve

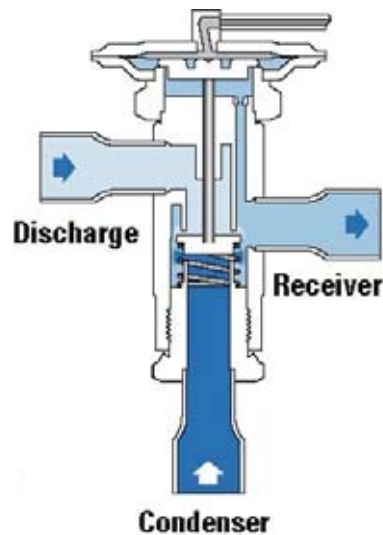

Refrigerant Migration

During an off cycle there is a potential for refrigerant to migrate from the warm receiver to the cold condenser. An auxiliary check valve should be used in the liquid line between the LAC valves and the receiver to prevent this from occurring. See Refrigeration Circuit Diagram on page 40-41.

Refrigeration System Re-Processing and Charging

Conforming to local and national codes is the responsibility of the service technician or installing contractor. The service technician should be familiar with the following codes:

- ASHRAE Standard Safety Code for Mechanical Refrigeration, ANSI/ASHRAE 15-1978
- American National Standard Code for Pressure Piping, ANSI B31.5-1974

Factory Tested

ClimaCool modular chillers have been pressure-tested, evacuated, fully charged and run tested at design water flow rates prior to shipment. In the unlikely event that a refrigerant leak is detected at startup, the following guidelines should be consulted before reprocessing the refrigeration systems.

Refrigerant System Reprocessing

Debris and moisture can enter copper tubing in a matter of minutes. All tubing, coil connections or any refrigerant containing portions should be temporarily capped or sealed to keep contaminants to a minimum. Filter driers should be opened just prior to brazing into the system to prevent moisture infiltration whenever possible, and flood the system with dry nitrogen while brazing to prevent oxidation inside the copper piping.

After all of the repairs have been made to the refrigeration system, a pressure test using refrigerant and nitrogen should be performed. Pressurize the system with dry nitrogen to 20 psi and check for any obvious leaks. If no leaks are present, introduce a “trace” amount of refrigerant to the system (raise system pressure to 30-40 psi). With a dry nitrogen tank equipped with a regulator set to 150 psi, continue to pressurize the system to 150 psi. Using a leak detector, carefully check the system for any remaining leaks. If the system is free of leaks you may release the pressure.

Evacuating the System

The compressors should never run while the system is in a vacuum. This could cause immediate failure to the compressors. After the system has been leak tested and sealed, any moisture that entered the system should be dehydrated and removed. While the pressure is reduced under a vacuum, the boiling point of moisture trapped inside the lines is also reduced. A pressure of .0095 psia, or 500 microns absolute pressure or better must be reached and sustained for several hours in order for the system to be considered free from moisture. It is necessary to use a micron meter equipped with an absolute pressure gauge (or transducer) to take this reading. ClimaCool recommends the double evacuation process to ensure the proper removal of moisture and contaminants from the refrigeration system. After the initial vacuum is reached and held on the system, allow dry nitrogen back into the system until the pressure reaches zero psig or slightly higher. Then, repeat the entire evacuation process described above. The evacuation process is considered complete **ONLY** after a successful “blank-off” test is performed.

A “blank-off” test is defined as:

- Pulling a vacuum level less than 500 microns on the system and holding it for several hours.
- Record the vacuum level in the system in microns, then close off the vacuum pump from the system for 15 minutes, and continue to monitor the micron level inside the refrigeration system.
- If the vacuum level inside the system does NOT rise more than 400 microns above the recorded vacuum level at the start of the 15 minute period, then the evacuation process is complete.

If the vacuum level rises more than 400 microns in 15 minutes, then continue to evacuate the system for 1-2 hours, and repeat a “blank-off” test.

Recharging the System

After all repairs have been completed, the system has been leak tested and proper vacuum pressures have been reached and maintained, refrigerant may be recharged into the system. With a known weight of refrigerant in the cylinder, use the gauge manifold set to connect the cylinder’s liquid charging port to the charging access port near the refrigerant liquid line valve. Gradually meter the appropriate weight of liquid refrigerant into the condenser side of the system first, until no additional refrigerant can be dispensed. Accurate refrigerant charge per circuit may be found in the Physical Data information on pages 3-5. Then continue the charging process by filling the evaporator side of the system with refrigerant. Close the refrigerant cylinder charging port, close all gauge manifold ports and start the compressor. Be careful when continuing to charge the balance of the refrigerant, constantly maintaining a positive compressor suction pressure (>25 psig) at all times.

General

Factory-assembled and wired remote air cooled chiller. Chiller consists of two compressors, one evaporator, safety and operational controls. The modular remote air cooled chiller shall incorporate one or more modules with two independent refrigerant circuits. Modules shall be capable of independent operation powered by a field installed fused disconnect switch (or equivalent module circuit breaker) supplied by others, so that any one module can be shut down for repair without interrupting the remaining remote air cooled chiller modules in operation.

Basic Construction

The frame design shall consist of heavy gauge galvanized steel with 3 mil powder coat paint finish baked at 350° for resilience in transport and installation and service access panels made of 18 gauge sheet metal with powder coat paint finish and quick release half turn latches. The module must have a low center of gravity, detachable schedule 40 carbon steel pipe water headers, designed to connect to adjacent modules through the use of 300PSI rated grooved couplings, base with cutouts for forklifts or pallet jacks.

Refrigeration Circuit

Each independent circuit shall consist of a scroll compressor, crankcase heater, and thermostatic expansion valve for refrigerant metering, sight glass, filter drier, solenoid valve, high and low pressure controls and safety controls. The modular chiller bank must be able to produce chilled water even in the event of a failure of one or more refrigerant circuits.

Evaporator

Each evaporator shall be highly efficient, refrigerant to water, dual circuited, brazed plate heat exchangers constructed of 316 stainless steel; designed, tested, and UL stamped in accordance with ASME Section VIII pressure vessel code for 650 psig working refrigerant pressure. The evaporator heat exchanger shall be mounted to eliminate the effect of migration of refrigerant to the cold evaporation with consequent liquid slugging on start-up. The evaporator shall be mounted on two layers of noise attenuating rubber isolation pads which also acts as a thermal barrier. The evaporator shall be wrapped with ¾ inch closed cell insulated blanket and closed cell insulation shall be provided on suction side refrigerant tubing including refrigerant to chiller heat exchanger to prevent condensation.

Air Cooled Condensers

Coils shall include aluminum fins mechanically bonded to enhanced copper tubes with integral subcooling circuits and rated for 650 psig. Condenser fan(s) shall be ultra-quiet, direct drive axial type with EC variable speed motors and integral head pressure control.

Compressors

Each module shall contain two scroll compressors independently circuited for redundancy. Each compressor shall be mounted with rubber isolated compressor mounts to the module base and each shall include compressor overload protection, high discharge pressure and low suction pressure cutouts.

Starter/Control Panel

Master Controllers shall be provided for individual control as well as system integration. The control shall consist of a simple two-conductor shielded daisy chain connection to allow communication between modules with minimal field wiring. The remote air cooled chiller control panel shall be a NEMA Type 1 enclosure including: power distribution block, compressor fusing, contactors, finger safe control fusing, transformer, isolation relays, status and alarm relay, 16-bit microprocessor master controller with built in native Building Automation System (BAS) communication protocols, (BACnet, LonWorks, Modbus and N2), status indicating lights showing: 1) compressor operation (on/off), 2) unit alarm status, 3) power on, two toggle switches to disable each individual compressor during start-up or troubleshooting.

Condenser – Remote Air Cooled

Remote air cooled condensers shall be constructed with galvanized steel casing, independent refrigeration circuits, 1140 RPM direct drive propeller and copper tube/aluminum fin condenser coils. The condenser coils shall have aluminum fins bonded to seamless copper tubes in a floating tube arrangement to eliminate tube sheet leaks with an aluminum fin selection spacing of 8, 10, 12 or 14 fins per inch. The condenser shall have a minimum of two refrigerant circuits, with single or dual ball bearing direct drive fan motors and equipped with PVC coated steel wire safety guards. Optional 540 or 830 rpm fan motors must be available for efficiency and/or low noise criteria applications. The remote air cooled condenser is to have a refrigerant design side working pressure of 650PSIG, pressure fan cycling control required for winter operation and flooded head pressure control valve used in conjunction with fan cycling for operation in areas with lower than 45°F ambient operation. Custom built control panel to interface with CoolLogic Control System.

CoolLogic Control System

Remote Master Control system shall be fully compatible with the Building Automation System via native BACnet and LonWorks, Modbus and N2 communication. Scheduling of the various compressors shall be performed by the master microprocessor based controller. A compressor run time equalization sequence is provided to ensure even

Engineering Guide Specifications

distribution of compressor run time. A load limit control shall be available to limit the number of compressors that can be energized at one time.

Starter/Control Panel

Module controls shall be provided for individual control as well as system integration. Simple two-conductor shielded daisy chain connection to allow communication between modules with minimal field wiring. Weatherproof NEMA 4 enclosure panel shall consist of power distribution block, control transformer, compressor and condenser fan contactors and fusing, isolation relays, 16-bit microprocessor control and two toggle switches to disable each individual compressor during startup or troubleshooting.

Optional CoolLogic Control System

The CoolLogic Control System shall be fully compatible with the Building Automation System via native BACnet, LonWorks, Modbus and N2 communication. Scheduling of the various compressors shall be performed by the master microprocessor based controller. A compressor run time equalization sequence is provided to ensure even distribution of compressor run time. A load limit control shall be available to limit the number of compressors that can be energized at one time. The CoolLogic Control System shall monitor and report the following for each refrigeration circuit in each module:

- Discharge pressure and temperature faults
- Suction pressure and temperature faults
- Compressor winding high temperature fault
- Low evaporator leaving chilled water temperature fault

The Master Controller shall monitor and report the following system parameters for the chiller system:

- Chilled water entering and leaving temperature
- Evaporator water flow availability

Any module failure condition shall cause a “fault” indication at the Master Control Panel and shutdown of that compressor circuit with the transfer of the load requirements to the next available module. In the case of a system “fault” the entire chiller will be shut down. When any fault occurs, the Master Control Panel shall record conditions at the time of the fault, and store the data for recall. This information shall be capable of recall through the keypad of the Master Control Panel and displayed on the 4 line by 40 character, back-lit LCD. A history of faults shall be maintained including date and time for each fault (up to the last 100 occurrences). The Master Control Panel monitors voltage/phase failure and internal leaving chilled water reset control will insure that the parallel evaporators

are operated above the freeze point for part load operation.

Factory Testing

Each remote air cooled chiller module shall be pressure-tested, evacuated and charged with nitrogen.

Options and Accessories

Free Cooling Modules

Directly couples to chiller bank. Includes: glycol free cooling coils, high efficiency, variable speed EC condenser fans with integral head pressure control with acoustical airfoil blade design providing low operating sound levels, two position motorized water isolation valve, 3-way bypass valves and fully integrated controls.

Hail Guards

Factory or field installed 18 gauge galvanized steel louver panels with powered coat paint finish for outdoor element protection.

Harsh Environment

Factory installed coil coating for outdoor element protection.

Heat Pump

Factory installed reverse cycle heat pump for heating and cooling operation.

Heat Recovery

Factory installed desuperheater provides hot water.

Hot Gas Bypass

Factory installed on both circuits allowing unit operation below the minimum step of unloading.

Low Ambient to -20°F

Factory installed variable speed fan control for all condenser fans provides optimum head pressure control. Liquid receivers, refrigerant relief valves and flood-back head pressure control valves are provided for all refrigerant circuits.

Manual Strainers

Field installed to increase efficiency and ensure long life of the equipment with Y-style and Basket strainers of cast iron 200 psi or carbon 275 psi with 60 mesh stainless steel screens. All strainers are field installed external to the chiller bank for ease of service.

Motorized or Manual Water Isolation Valves and Flush Ports

Factory installed water isolation valves and flush ports shall provide isolation to the module for maintenance and cleaning of evaporator heat exchangers while adjacent modules continue normal operation. Both motorized and manual valves include standard ¾" fill and flush valves. **Note: All Heat Pump configurations require motorized valves.**

Available choices include:

- One each motorized valve for evaporator with one each manual valves for the evaporator.
- Two each manual valves for the evaporator.

Pressure Differential Flow Sensor

Field installed to prevent operation of chiller without sufficient water flow to the evaporator.

Pump Module

Module includes primary and standby centrifugal pumps in a lead/lag configuration coupled to the common chiller header and controlled through the *CoolLogic* Control System.

Simultaneous Heating and Cooling

Factory installed patent pending, four (4) header design SHC heat pump satisfies required heating and cooling demands with the use of integral header isolation valves and controls. Allows any module to be indexed for heating or cooling regardless of its position in the bank. Provides hot water, as high as 135°F.

Water Header Bypass

Field installed to prevent deadheading the pump, a water header bypass may be field installed and is mandatory when using motorized valves.

Options available:

- Direct return with motorized evaporator/isolation valves
- Reverse return with motorized evaporator/isolation valves

Weatherproof Enclosure

Field installed Nema 4 enclosure for *CoolLogic* Master Panel.

Stainless Steel Strainer Option

Figure 29 - Stainless Steel Strainer

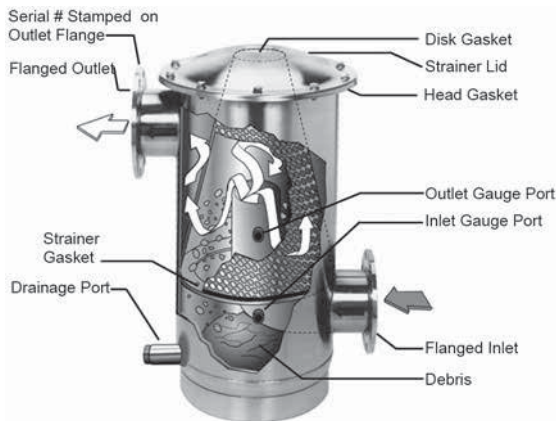

Safety Considerations

Prior to installation, this manual must be read carefully and all instruction understood. Personal injury or product damage can occur if the following safety precautions are overlooked or ignored. We strongly recommend that you follow these safety precautions and avoid the potential hazards listed below when operating and maintaining the strainer:

1. After unpacking your strainer, carefully inspect your strainer housing, lid assembly and screen for damaged or missing parts. Contact ClimaCool's customer service department for any replacement parts.
2. The strainer should not be modified or used in a manner not consistent with the manufacturer's recommendations. If there are any questions regarding its application or installations, contact ClimaCool's customer service department.
3. **Absolutely under no conditions should the strainer lid or pressure gauges be removed while the strainer is pressurized.**
4. Standard bolted lid models should never exceed 150 psi; V-Band clamp models should never exceed 125 psi.
5. Install back-flow prevention devices (or check valves) both upstream and downstream of the strainer to prevent back flow or vacuum effects which can cause damage to the strainer housing or screen.
6. Install properly sized pressure relief valves both upstream and downstream of the strainer. This will help prevent damage to the strainer and screen in the event that water flow is stopped abruptly, or if water hammering occurs. The pressure relief valves should be set to relieve pressure at 1.2 times the strainer's maximum operating pressure (not to exceed the maximum rated pressure). Consult your local dealer or pressure relief valve manufacturer to obtain properly sized valves for your application.

Note: Minimum 60 mesh screen is required. At no time should the internal pressure exceed the maximum rated pressure of the strainer.

Strainer Installation Recommendations

Follow the recommended guidelines below for strainer installation:

1. The Carbon Steel strainer should be placed on a firm, supporting surface. Failure to do so can cause stress on the weld joints. It is recommended a concrete pad be poured under the base of the strainer. The weight of the CS strainer should not be supported by the main water lines connecting it.
2. The inlet and outlet connections should be securely fastened. The arrows depict flow direction (see Figure 29).
3. The back-mount pressure gauges should be installed in the gauge ports located on the front of the strainer body. These gauges will allow you to monitor the pressure differential across the strainer screen providing an indication when the strainer element is clogged and requires cleaning.
4. The CS strainer lid must be securely fastened according to the following torque specifications to ensure product safety and an adequate seal.

Torque Specifications

Clamped Lid Models: CS strainer models 3CS and 4CS have "over-center latch clamp" lid designs. The over-center clamp does not require adjustment when installing or removing the lid. The lock washer is set at the factory for proper clamp compression and normally requires no field adjustment. Minor tightening may be necessary over time. The lids are installed as follows:

1. Place the clamp around the strainer lid.
2. Latch the T-bolt with the receiver and push the latch handle towards the strainer body until the safety catch engages.

Bolted Lid Models: CS strainer models 6CS, 8CS and 10CS have "bolted" lid designs. Grade 5 zinc-plated bolts, nuts and washers are used to attach the lids to these strainers. See Table 8 for proper lid bolt size and torque rating for each strainer (page 48). (Exercise care when tightening the lid bolts so as not to damage the strainer lid or housing).

It is important to follow the torque specifications as over-tightening may result in premature failure of the bolts. It is equally important to follow a star wheel torque pattern when tightening the lid bolts (see Figure 30). The strainer lid may not be seated down completely after the first torque sequence. A second torque sequence should be adequate to seat the lid securely to the body.

Stainless Steel Strainer Option

Table 8 - Bolt Size and Recommended Torque

Strainer	Bolt Size (inches)	Recommended Torque (ft. lbs)
3CS	5/16 - 18	60 - 80
4CS	3/8 - 16	15 - 25
6CS	1/2 - 13	45 - 55
8CS	1/2 - 13	45 - 55
10CS	5/8 - 11	80 - 100

Figure 30 - Recommended Torquing Sequence

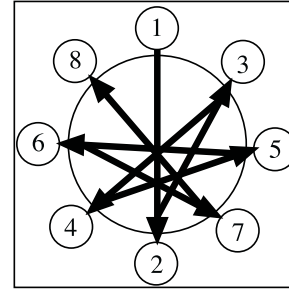

Strainer Operation

Periodically, it will be necessary to flush out the debris that is collected and settles to the bottom of the strainer reservoir. CS-3 strainers must have a valve installed on the drainage port. The larger CS strainers (4CS, 6CS, 8CS and 10CS) are equipped with a flush port (or drainage port) extending inside the strainer. When it becomes time to clean the strainer, the flush port valve should be opened while the strainer is in operation (while pressurized and with water flowing). A thorough flushing of the strainer reservoir will depend upon the length of time the flush valve remains opened. This flush time will typically range from 15 to 60 seconds depending on the flow, inlet water pressure and the amount of debris collected by the strainer. As a general rule, the larger strainers will require higher inlet water pressures in order to achieve a complete flushing. For example, the 4CS model can be flushed with inlet water pressures as low as 15-20 psi, while the 6CS can be flushed with 30-35 psi. The 8CS and 10CS models should be flushed with inlet water pressures greater than 40 psi.

Note: When shutting down the chiller for extended periods of time, the strainer should be isolated and completely drained.

Strainer Element Cleaning

If your strainer assembly is equipped with optional pressure gauges, you will be able to monitor the pressure differential between the inlet and outlet sides of the strainer. When this pressure differential reaches 5-10 psi the strainer element may require cleaning.

Caution: Prior to dismantling the strainer for cleaning, it is imperative that the strainer assembly is isolated and completely de-pressurized.

Follow the steps below when cleaning the CS strainer element:

- Step 1.** (Bolted Lid Models): Remove the top of the strainer by removing the Grade 5 Zinc plated bolts from the lid.
- Step 1.** (Clamped Lid Models): Remove the top of the strainer by taking off the band-clamp assembly.*
- Step 2.** Lift the strainer element (conical screen) out of the strainer body.

- Step 3.** Carefully scrub down the strainer element with a rigid nylon brush until all matter is loosened.
Do not use a steel brush.
- Step 4.** Wash the strainer element off with clean water. It is preferable to use a hose with a significant amount of water pressure.
Do not use a pressure washer.
- Step 5.** Wash all matter from the strainer gaskets and clean the inner-ring where the bottom of the strainer element rests.
- Step 6.** Make sure the U-shaped gasket is fitted securely to the bottom of the strainer element.
Reposition the strainer element into the body of the strainer.
- Step 7.** Make sure the strainer head gasket is secure on top of the strainer body. On V-band models, O-rings should be seated completely in the body flange. Reposition the strainer lid back on the strainer body. **Tighten the lid securely either with the bolts or with the band-clamp.**

* For clamped models, opening and closing is achieved without adjusting the lock nut. It is tightened at the factory to the correct compression. (Minor tightening may be necessary if the gasket loses memory over time.) To open the clamp, depress the safety latch and pull the over-center lever outward. To close the clamp, make sure the T-bolt is seated in its receiver and push the over-center lever back toward the strainer housing. **Be sure that the safety latch is engaged before putting the unit to use.**

Stainless Steel Strainer Option

What is Water Hammer?

Water hammer is a phenomenon that can occur in fluid systems with long pipes. Water hammer is a rapid change of pressure caused by a rapid change in velocity. If the flow has been abruptly shut off downstream, the pressure in the entire system is raised very quickly.

What Causes Water Hammer?

Any action that can cause a rapid change in the velocity of the flow can set off a water hammer, such as closing a downstream valve, pump stoppage, etc. Typically, for short lengths of pipe (below 500 feet) downstream valves that are closed within 1/10 of a second can generate water hammer.

What Can Water Hammer Do?

Pressure spikes from water hammer can raise fluid pressures to dangerously high values. These pressure spikes can cause serious damage to valves, pipes, strainers, joints, etc. The CS strainer is rated to an absolute maximum pressure of 150 psi for bolted lid models, and 125 psi for clamped lid models. A water hammer pressure spike that raises the pressure higher than the maximum rated pressure may result in strainer damage, voiding the manufacturer's warranty.

What Can I Do to Prevent Water Hammer?

There are certain precautions that can be taken to prevent or decrease the effect of water hammer. The addition of a surge tank or accumulator fitted with a suitable pressure relief valve strategically located within the water system may provide adequate protection against the effects from water hammer. Careful attention should be given to the design and control strategy for valves and pumps so their actions do not invite a water hammer.

Stainless Steel Strainer Options

Automatic Timer Flush (ATF) Package Option

The ATF-EA-1.5 flush valve package provides an automatic method for flushing away the debris collected in the strainer's reservoir. The power supply and timer controls for the valve package are housed inside the ATF control box. The ATF controls can be pre-programmed to set the flushing duration and the time interval between flushes.

System Components

1. Timer based valve controller: (see Figure 31) sets the flush duration (length of the flush) and the flush interval (time between flushes).
2. Electric Ball Valve: designed for dirty water use (see Figures 31 and 32).

Figure 31 - Timer Based Valve Controller

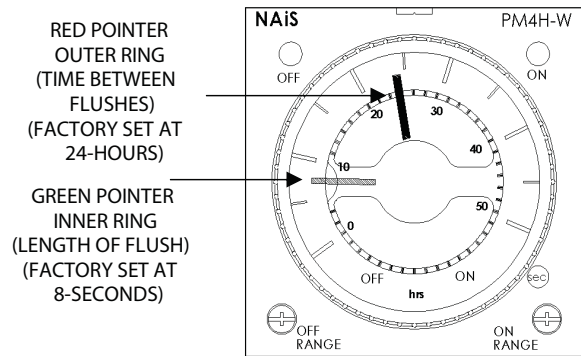

Figure 32 - Electric Ball Valve

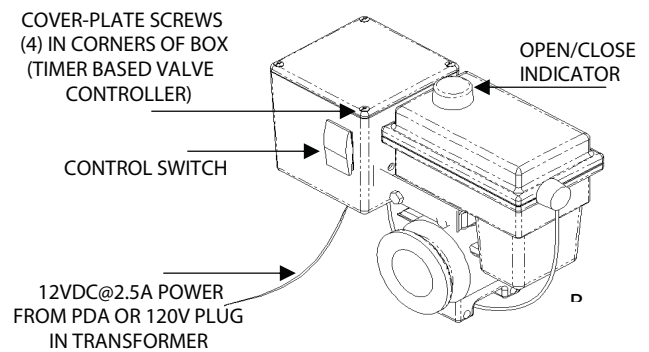
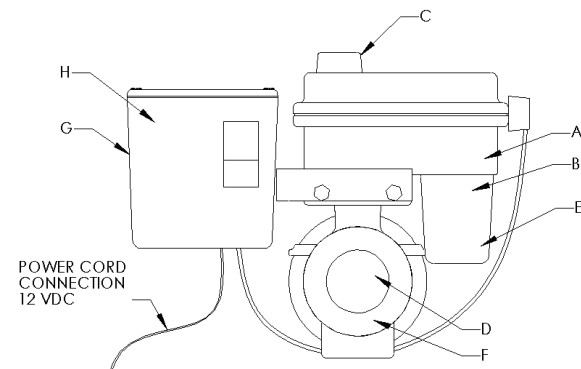

Figure 33 - Valve Specifications



Valve Specifications (See Figure 33)

- A. Water-resistant polypropylene motor case
- B. High torque motors with perma-lube gears
- C. Open and close indicator
- D. Stainless steel ball valve and hardware
- E. Auto reset circuit breaker
- F. 90° F bi-directional rotation
- G. Controller case

Stainless Steel Strainer Option

Operation Instructions

Flush valve line must be piped to atmospheric pressure such as an open floor drain. The flush line should not undergo any changes in elevation and should be sloped downward in the direction of drainage. **Do not pipe the flush or drain line into a pressurized line.**

Note: The Automatic Timer Flush Package needs to be programmed when it is received by the end-user. The programming is simple and takes only a few moments. However, because every application has different parameters that affect the required frequency between flushes and the duration of the flush, the end-user must choose the controller's settings (refer to your specific strainer manual).

Programming the ATF Controller

1. Plug the transformer into a 120-VAC outlet.
2. Insert the 12-VDC plug coming from the transformer into the jack on the underside of the ATF box.
3. Test for power by pressing the manual flush side of the control switch (lower switch light should come on then the valve will start to open).
4. Adjust the "ON TIME" (Valve Open) by turning the inner timer ring with the GREEN POINTER clockwise to increase duration. The ON TIME RANGE is factory set at eight seconds. (See Figure 31 on page 49).
5. Adjust the "OFF TIME" (Valve Close) by turning the outer ring with the RED POINTER clockwise to increase duration. The OFF TIME RANGE is factory set at twenty-four (24) hours. (See Figure 31 on page 49).
6. Set the control switch to auto flush. The red off light on the timer will come on and the upper light on the switch will come on and stay on. During the flush cycle the on light on the timer and the lower switch light will come on.

Control Switch

Control switch flushing is initiated by pressing and holding down the manual control switch located on the front of the controller (See Figure 32 on page 49). The manual flush control switch can also be used to conveniently drain the water out of the strainer before removing the conical screen element from the strainer housing. A yellow indicator arrow on top of the ATF valve will rotate in sync with the ball valve to show the valve position (open or closed). When the manual flush control switch is released, the valve will automatically close.

SAFETY FIRST! - Keep fingers away from valve opening to avoid getting caught in the moving parts. The electric motor supplies a sufficient amount of power to cause personal injury. Take precaution when handling.

Water Resistance

The valve and controller are water-resistant, not water-proof. Do not install below ground level where the component can be submerged in water. Only remove the cover plate from the valve controller when setting or changing the flush settings. Keep the cover tightly sealed on the unit during normal operation.

Pressure Differential Alarm Package Option

The pressure differential alarm (PDA) option continually monitors and displays the strainer's inlet and outlet differential pressure. When the strainer element (conical strainer basket) becomes significantly clogged, the pressure differential switch-gauge will trigger an audible siren and a visual flashing alarm light. These alarms are intended to alert maintenance personnel that the strainer element must be removed and cleaned (See Strainer Element Cleaning on page 48).

Figure 34 - Pressure Differential Alarm

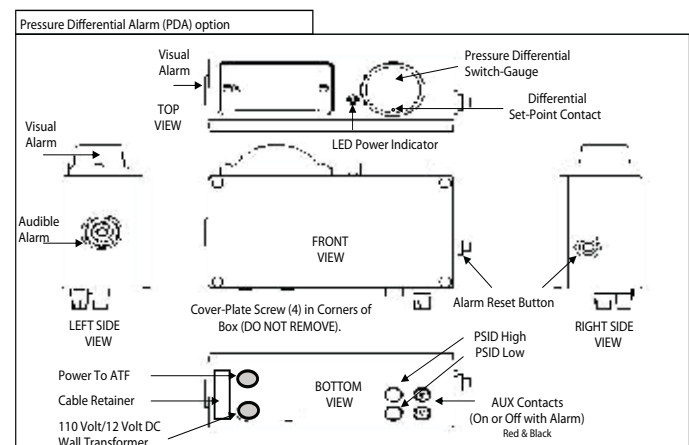

Operation Instructions

Remove the power supply and insert the connector end into the socket on the bottom of the PDA housing (See Figure 34 above) and plug the transformer into the power source. Standard systems are supplied with a 120V power supply to the primary of the transformer, with an output secondary of 12 VDC. The pressure differential switch-gauge is factory set to 7-8 psi. The CS strainer operates at a pressure differential slightly less than 1 psi during maximum flow when the strainer screen is clean. By the time the differential pressure reaches 7-8 psi, the strainer element will be significantly clogged and require immediate removal and cleaning. To adjust the pressure differential switch-gauge setting, insert a 1/16" allen wrench and rotate the differential set point contact to the desired location (See Figure 34). **Note: It is not recommended to set the differential switch-gauge higher than 10 psi. Disabling the alarm or increasing the alarm set point could result in damage to the strainer element and allow debris to pass into the system.**

Stainless Steel Strainer Option

When the differential set point is reached, both the audible and visual alarms will be triggered and will remain engaged until both the alarm condition is corrected and the alarm-reset button is pressed (if the alarm-reset button is pressed but the differential pressure is beyond the set point, the alarms will re-engage immediately). After the strainer is cleaned and put back in service, the differential pressure should return to 1 psi.

Auxiliary Contacts

The PDA option is equipped with a remote alarm feature. The remote alarm contacts are located at the two black and red banana clip posts (See Figure 34 on page 50). The alarm can be set up in one of two ways:

1. A remote alarm signal of 12 VDC can be sent to a central monitoring station.
2. A set of auxiliary contacts will indicate a “closed” condition when the alarm activates (Locate the Auxiliary Contact Schematic inside the PDA box by removing the four screws on the cover plate).

Water Resistance

The Pressure Differential Alarm Controller is water-resistant, not water proof. Do not install below ground level where the box can be submerged in water. **Do not remove** the cover plate from the PDA controller. Keep the cover tightly sealed on the module during normal operation.

Table 9 - Troubleshooting for ATF Package

Problem	Solution	
Valve is leaking past ball	• Seals damaged or worn out	• Install repair kit
	• Valve is not stopping at proper closed position	• Adjust limit switches
Valve stem leaks	• Worn stem seals	On metal valves: tighten stem packing nut 1/2 turn. CAUTION! Over tightening stem nut could cause drag on motor and trip internal circuit breaker. May require repair kit or new valve.
Valve body leaks	• Loose body bolts or excessive operation pressure	• Check bolts and observe recommended pressure ratings
	• Defective seals	• Install repair kits or new valve
Valve hard to turn	• Swollen seals or product buildup in valve chamber	• Check valve for compatibility with product, may require valve cleaning or new valve
	• Valve bolts too tight	• Loosen bolts slightly
	• Stem nut too tight	• Loosen stem nut slightly

WYE Strainers

The correct size of the WYE Strainer is determined by its job function, not by the size of the pipeline.

Pre Installation Checklist:

1. Ensure working conditions (pressure/temperature) are within the specified capacity of the product being installed. Please refer to the certified drawings to assist in determining these values.
2. Inspect all sealing surfaces to ensure gasket surfaces are free of defects (no nicks or cuts). The pipeline should also be checked for proper alignment. WYE strainers should never be utilized to realign an existing piping system.
3. Ensure that the pipeline's mating flanges are the same type as the WYE strainer being installed. Raised face flange ends cannot be mated to flat face flange ends.
4. Ensure strainer end-to-end length and installation gap are within $\frac{1}{4}$ in gap for gasket, and have sufficient clearance for easy opening of cover and screen removal.
5. If the WYE strainer is to be located on the discharge side of a pump, then a safety release valve must be installed between the WYE strainer and the pump.

Figure 35: WYE Strainer Straining Illustration

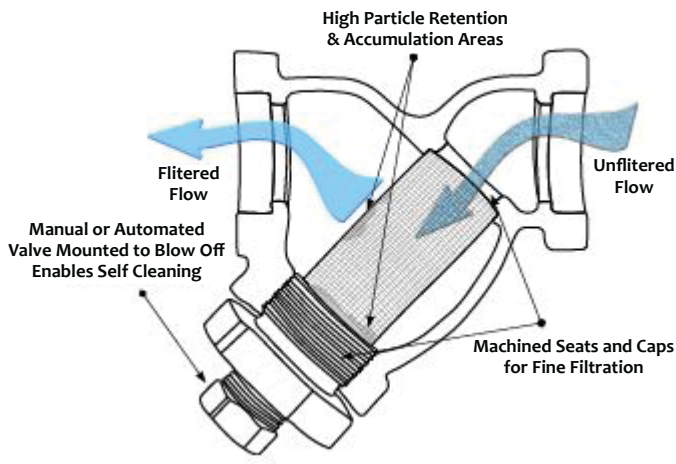

Figure 36: WYE Strainer - Flanged Ends



Installation Procedure:

1. Also, for maximum efficiency, install a differential pressure gauge at inlet and outlet connections or at the strainer gauge tap (if provided).
2. WYE strainers must be positioned in the pipeline ahead of the equipment requiring protection.
3. To provide for easier maintenance, the WYE strainer should be located where the drain plug can be removed. Additionally, ensure the drain is located at the lowest position when installed. If installed in the vertical position, the WYE side of the strainer must be pointing downward.
4. Ensure there is ample space at the WYE side of the strainer for screen removal.
5. Before placing the WYE strainer into place, support the existing pipeline with pipe supports near the inlet and outlet connections.
6. Place the WYE strainer into the pipeline ensuring that the flow arrow on the body of the WYE strainer is pointing in the direction of the pipeline flow. For large or heavy strainers, appropriate material handling equipment must be used.
7. Install a standard ANSI ($\frac{1}{8}$ " thick) flange gasket between the WYE strainer and pipeline flanges, on both sides. Install lubricated flange bolts and hand tighten. Flange bolts should then be tightened, using a star or crisscross pattern to evenly load the bolts, in accordance with established piping standards. This is illustrated in figure 37.

Figure 37: Bolting Sequence Pattern

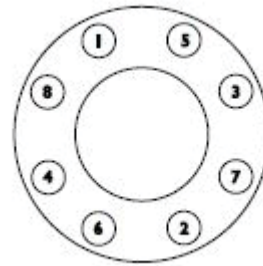

Note: Excessive bolt torque may damage flanges. Please refer to established flange bolt torques for guidelines.

Operation

Once proper installation has been successfully completed, start the system gradually, at start up as well as after shut down. This eliminates sudden shock to the strainer and other equipment in the line. This is extremely important for steam service.

Start-Up Procedure

1. To remove all fluid from the strainer belly, a drip-leg can be installed or the piping can be placed at a $\frac{1}{4}$ " slope.

WYE Strainers

Note: With piping systems that contain fluids other than water or when the working temperature is above 120°F, fluid must be drained to safe area, away from the operator. Operators should always be fitted with appropriate equipment (goggles, gloves, vests etc.) when venting or servicing is performed.

2. Start the piping system, by opening the outlet valve nearest the WYE strainer's outlet first. Then gradually open the inlet valve nearest the WYE strainers' inlet, approximately 25% of normal operational flow. It is important to start the system gradually to avoid displacing or damaging the WYE strainer.
3. Continue to open the inlet valve until the desired service flow has been reached.

4. Remove screen and clean. Do not permit screen to dry as it will be difficult to remove debris after it has hardened. Avoid banding or hitting the screen to remove stubborn debris.
5. Inspect screen and cover gasket for damage. If either is damaged, replace. Always ensure there is a spare gasket and screen on hand prior to maintenance.
6. Remove any debris or sludge from within the strainer.
7. Replace cleaned or new screen into its original position, ensuring it is squarely positioned on the screen.
8. Replace cover gasket and cap or cover. Tighten cap or cover to specified torque rating.

Follow the Start-up procedure outlined within the Operation Instructions.

Maintenance

WYE strainers require little monitoring once they are properly installed. The pressure differential across the strainer should be checked periodically to determine if the screen needs to be cleaned or replaced. If the pressure differential goes unchecked and the screen becomes completely clogged, the screen will break and require replacing. **Note:** Strainer screens are not designed to withstand the same pressure ratings as the housings. If the screen becomes completely clogged, it will be exposed to the same pressure as the housing. In most cases, this will cause the screen to fail and potentially damage downstream equipment.

Regular maintenance involves:

- Timely cleaning or replacement of screen
- Periodically checking for leaks

During normal use, the screen will become clogged with foreign matter, causing the differential pressure to increase. Once the differential pressure has increased to an unacceptable value, typically by 5 psi to 10 psi, it is time to clean or replace the screen. It is not advisable to let the differential pressure increase by 20 psi. This may cause the screen to fail and possibly damage downstream equipment.

A convenient and safe way to determine when the screen needs to be replaced is to install pressure gauges on the inlet and outlet sides of the strainer. The maximum acceptable pressure drop across the strainer will indicate when the screen needs to be replaced. Screen size and construction determine the maximum pressure drop that a strainer screen can withstand.

Screen Removal/Cleaning/Replacement

1. Isolate the strainer by closing the inlet and outlet valve connections on either side of the WYE strainer. Make sure valves are bubble tight.
2. Open vent to relieve pressure inside and drain fluid from the strainer.
3. Once pressure is relieved, remove the WYE side cap or cover.

Basket Strainers

The correct size of Basket Strainer is determined by its job function, not by the size of the pipeline.

Pre Installation Checklist:

1. Inspect the basket strainer's flange ends and the pipeline's mating flanges to ensure gasket surfaces are free of defects. The pipeline should also be checked for proper alignment. Strainers should never be utilized to realign an existing piping system.
2. Ensure that the pipeline's mating flanges are the same type as the basket strainer being installed. Raised face flange ends cannot be mated to flat face flange ends.
3. Ensure that the pipeline setup allows a horizontal installation of the basket strainer.
4. If pipeline strain is a concern when installing larger basket strainers (6" and above), a concrete or steel pad should be used to provide additional support. Larger basket strainers can also be fitted with legs to assist in reducing strain on the pipeline.
5. If the basket strainer is to be located on the discharge side of a pump, then a safety release valve must be installed between the basket strainer and the pump.

Figure 38 - Installed Basket Strainer with Bolted Cover

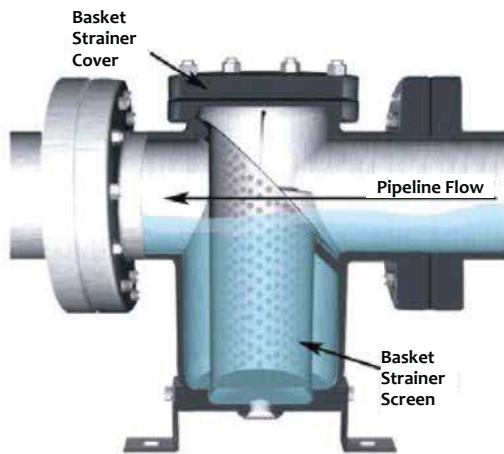

Installation Procedure:

1. To provide for easier maintenance, the basket strainer should be located where the drain plug can be removed and where there is ample space above the basket strainer for screen removal.
2. Before placing the basket strainer into place, support the existing pipeline with pipe supports near the inlet and outlet connections of the basket strainer.
3. Place the basket strainer into the pipeline ensuring that the flow arrow on the body of the basket strainer is pointing in the direction of the pipeline flow. For large or heavy strainers, lift the basket strainer into place using slings positioned underneath the inlet and outlet connections.

4. Install a standard ANSI ($\frac{1}{8}$ " thick) flange gasket between the basket strainer and pipeline flanges, on both sides. Install lubricated flange bolts and hand tighten. Flange bolts should then be tightened, using a star or crisscross pattern to evenly load the bolts, in accordance with established piping standards. This is illustrated in figure 39.

Figure 39: Bolting Sequence Pattern

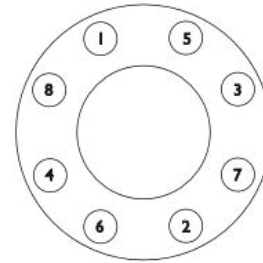

Note: Excessive bolt torque may damage flanges. Please refer to established flange bolt torques for guidelines.

Operation

Once proper installation has been successfully completed, start the system gradually, at start up as well as after shut down. This eliminates sudden shock to the strainer and other equipment in the line. This is extremely important for steam service.

Start-Up Procedure

1. Remove air from the pipeline by opening the vent near the basket strainer. **Note:** With piping systems that contain fluids other than water or when the working temperature is above 120°F, fluid must be drained to safe area, away from the operator. Operators should always be fitted with appropriate equipment (goggles, gloves, vests etc.) when venting or servicing is performed.
2. Start the piping system by opening the outlet valve nearest the basket strainer's outlet first. Then gradually open the inlet valve nearest the basket strainer's inlet, approximately 25% of normal operational flow. It is important to start the system gradually to avoid displacing or damaging the basket strainer.
3. Continue to open the inlet valve until the desired service flow has been reached.

Basket Strainers

Maintenance

Basket strainers require little monitoring once they are properly installed. The pressure differential across the strainer should be checked periodically to determine if the screen needs to be cleaned or replaced. If the pressure differential goes unchecked and the screen becomes completely clogged, the screen will break and require replacing. **Note:** Strainer screens are not designed to withstand the same pressure ratings as the housings. If the basket becomes completely clogged, it will be exposed to the same pressure as the housing. In most cases, this will cause the basket to fail and potentially damage downstream equipment.

Regular maintenance involves:

- Periodically checking for leaks
- Timely cleaning or replacement of screen

During normal use, the basket will become clogged with foreign matter, causing the differential pressure to increase. Once the differential pressure has increased to an unacceptable value, typically by 5 psi to 10 psi, it is time to clean or replace the screen. It is not advisable to let the differential pressure increase by 20 psi. This may cause the screen to fail and possibly damage downstream equipment.

A convenient and safe way to determine when the screen needs to be replaced is to install pressure gauges on the inlet and outlet sides of the strainer. The maximum acceptable pressure drop across the strainer will indicate when the screen needs to be replaced. Screen size and construction determine the maximum pressure drop that a strainer screen can withstand. Please consult factory for exact pressure ratings.

Strainer Element Cleaning

Before removing the cover of the basket strainer, the pressure inside the vessel must be reduced to atmospheric via suction or venting. Failure to do so may result in serious bodily injury.

1. Isolate the basket strainer by closing the inlet and outlet valve connections on either side of the basket strainer.
2. Open vent or drain plug to relieve pressure inside the basket strainer. Drain fluid up to screen seat level.
3. Once pressure is relieved, remove the cover.
4. Remove baskets and clean. Avoid banging or hitting the screen to remove stubborn debris.
5. Inspect basket and cover gasket for damage. If either is damaged, replace. Always ensure there is a spare gasket and basket on hand prior to maintenance.
6. Remove any debris or sludge from within the basket strainer.

7. Replace clean basket into its original position, ensuring it is squarely positioned on the screen seat.
8. Replace cover gasket and replace and tighten cover.

Follow the Start-up procedure outlines within the Operation Instructions.

Electrical Data - UCA, Cooling Only and Heat Pump

ClimaCool Base Model	Typical Model #	Voltage	Power Wiring - per Module						Internal Wiring - Cond. Fans ¹⁰				Internal Wiring - per Compressor			
			Rated Load Amps ¹	Min. Cir. Amps (MCA) ²	MaxFuse Size (MOP) ^{3,8}	Rec. Fuse ^{4,8} Size	Discon. Switch ⁹ Size	Rated Load Amps ¹	Min. Cir. Amps (MCA) ²	MaxFuse Size (MOP) ³	Rated Load Amps ¹	Min. Cir. Amps (MCA) ²	Locked Rotor (LRA) ⁵	MaxFuse Size (MOP) ³	Rec. Fuse ⁴ Size	
UCA020BH	UCA020BHASAC00S	208V-230V/ 3PH/ 60HZ	86.2	96.3	125.0	110.0	150.0	4.5	5.6	10.0	40.3	50.3	239.0	90.0	60.0	
UCA020BF	UCA020BFASAC00S	460V/ 3PH/ 60HZ	39.2	43.8	60.0	50.0	60.0	2.3	2.9	7.5	18.3	22.9	125.0	40.0	30.0	
UCA020BN	UCA020BNASAC00S	575V/ 3PH/ 60HZ	31.0	34.5	45.0	40.0	50.0	2.1	2.6	6.0	14.3	17.9	80.0	30.0	25.0	
UCA030BH	UCA030BHASAC00S	208V-230V/ 3PH/ 60HZ	133.4	149.0	200.0	175.0	200.0	7.0	8.8	15.0	62.6	78.2	340.0	125.0	90.0	
UCA030BF	UCA030BFASAC00S	460V/ 3PH/ 60HZ	60.7	67.8	90.0	80.0	100.0	3.6	4.5	10.0	28.4	35.5	173.0	60.0	45.0	
UCA030BN	UCA030BNASAC00S	575V/ 3PH/ 60HZ	50.3	56.1	70.0	70.0	80.0	3.4	4.3	7.5	23.3	29.1	132.0	50.0	40.0	
UCA050BH	UCA050BHASAC00S	208V-230V/ 3PH/ 60HZ	203.2	227.3	300.0	300.0	350.0	8.0	10.0	10.0	96.4	120.5	436.0	200.0	150.0	
UCA050BF	UCA050BFASAC00S	460V/ 3PH/ 60HZ	91.7	102.6	150.0	125.0	150.0	4.0	5.0	5.0	43.6	54.5	212.0	90.0	70.0	
UCA050BN	UCA050BNASAC00S	575V/ 3PH/ 60HZ	73.5	82.2	110.0	100.0	125.0	3.2	4.1	4.0	34.9	43.6	168.0	70.0	60.0	
UCA070BH	UCA070BHASAC00S	208V-230V/ 3PH/ 60HZ	296.6	331.1	450.0	400.0	450.0	18.0	22.5	15.0	138.1	172.6	635.0	300.0	225.0	
UCA070BF	UCA070BFASAC00S	460V/ 3PH/ 60HZ	133.3	148.9	200.0	175.0	200.0	8.0	10.0	10.0	62.4	78.0	280.0	125.0	100.0	
UCA070BN	UCA070BNASAC00S	575V/ 3PH/ 60HZ	108.0	120.5	150.0	150.0	175.0	7.6	9.5	7.5	50.0	62.5	225.0	100.0	80.0	

NOTES:

1. RLA - Rated Load Amps are calculated as per UL 1995.
2. MCA - Minimum Circuit Ampacity is: 125% of the RLA of the largest compressor motor plus 100% of the RLA of all other concurrent motors and/or electrical loads.
3. MOP -Maximum Overcurrent Protection or Max. Fuse Size is rounded down from: 225% of the RLA of the largest compressor motor plus 100% of the RLA of all other concurrent electrical loads.
4. Recommended Dual Element Fuse Sizing: Rounded up from 150% of the RLA of the largest compressor motor plus 100% of the RLA of all other concurrent electrical loads.
5. LRA - Locked Rotor Amps are instantaneous starting amperage per compressor.
6. Module internal wiring is per NEC.
7. Voltage Tolerance Range
 208-230V / 60 Hz: Min. 187V Max. 253V
 460V / 60 Hz: Min. 414V Max. 506V
 575V / 60 Hz: Min. 518V Max. 632V
8. MOP Device or Recommended Fusing Device for Module Power Wiring supplied by others. These are recommended values for electrical power protection of modules selected.
9. Disconnect Switch for Module Power Wiring supplied by others. These are recommended values for electrical power protection of modules selected.
10. Condenser fans are fused in pairs for 070 models as shown in their respective electrical diagrams.

Electrical Data - Model UCF, Free Cooling

ClimaCool Base Model	Typical Model #	Voltage	Power Wiring - per Module				Internal Wiring - Cond. Fans ¹⁰			
			Rated Load Amps ¹	Min.Cir. Amps (MCA) ²	MaxFuse Size (MOP) ^{3,8}	Rec. Fuse ^{4,8} Size	Discon. Switch Size ⁹	Rated Load Amps ¹	Min.Cir. Amps (MCA) ²	MaxFuse Size (MOP) ³
UCF030BH	UCF030BHA00000S	208V-230V/ 3PH/ 60HZ	9.9	11.1	20.0	15.0	15.0	9.2	10.4	15.0
UCF030BF	UCF030BFA00000S	460V/ 3PH/ 60HZ	5.1	5.7	15.0	7.5	15.0	4.8	5.4	7.5
UCF030BN	UCF030BNA00000S	575V/ 3PH/ 60HZ	4.7	5.2	15.0	7.0	15.0	4.4	5.0	7.0
UCF070BH	UCF070BHA00000S	208V-230V/ 3PH/ 60HZ	19.1	11.1	20.0	15.0	15.0	18.4	10.4	15.0
UCF070BF	UCF070BFA00000S	460V/ 3PH/ 60HZ	9.9	5.7	15.0	7.5	15.0	9.6	5.4	7.5
UCF070BN	UCF070BNA00000S	575V/ 3PH/ 60HZ	9.1	5.2	15.0	7.0	15.0	8.8	5.0	7.0

NOTES:

1. RLA - Rated Load Amps are calculated as per UL1995.
2. MCA - Minimum Circuit Ampacity is: 125% of the RLA of the largest compressor motor plus 100% of the RLA of all other concurrent motors and/or electrical loads.
3. MOP -Maximum Overcurrent Protection or Max.Fuse Size is rounded down from: 225% of the RLA of the largest compressor motor plus 100% of the RLA of all other concurrent electrical loads.
4. Recommended Dual Element Fuse Sizing: Rounded up from 150% of the RLA of the largest compressor motor plus 100% of the RLA of all other concurrent electrical loads.
5. LRA - Locked Rotor Amps are instantaneous starting amperage per compressor.
6. Module internal wiring is per NEC.
7. Voltage Tolerance Range
 208-230V / 60 Hz: Min. 187V Max. 253V
 460V / 60 Hz: Min. 414V Max. 506V
 575V / 60 Hz: Min. 518V Max. 632V
8. MOP Device or Recommended Fusing Device for Module Power Wiring supplied by others. These are recommended values for electrical power protection of modules selected.
9. Disconnect Switch for Module Power Wiring supplied by others. These are recommended values for electrical power protection of modules selected.
10. Condenser fans are fused in pairs for 070 models as shown in their respective electrical diagrams.

Power Distribution Drawing

Figure 40 - Power Distribution Drawing

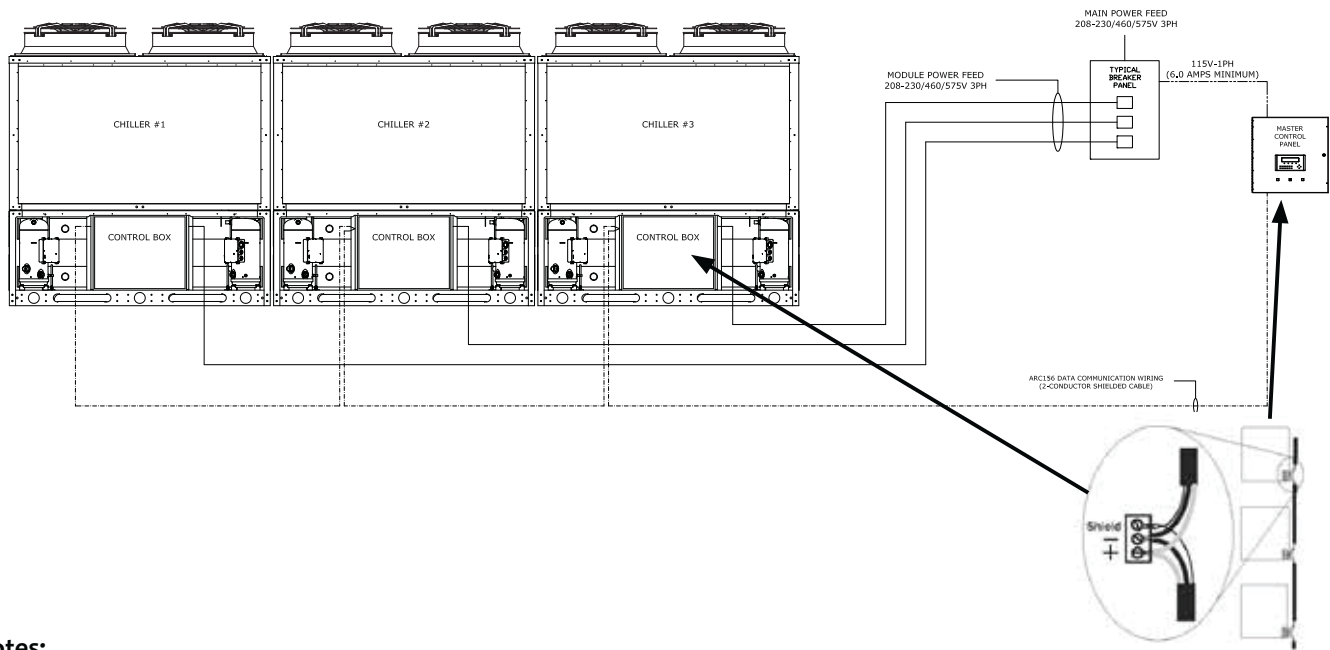

Notes:

1. Breaker panel represents field power supply and is to be installed by others. Not provided as part of ClimaCool modular chiller system.
2. Breaker panels can be supplied for skid mount pump/tank packages or new construction projects as options. Consult your local ClimaCool representative.
3. Control wiring is by others.
4. Field connections are simplified requiring only a two-conductor shielded cable daisy chain from the master controller to the modules.

Specifications for ARC156 Wiring

- Description - Single twisted pair, low capacitance, CL2P, TC foam FEP, plenum rated cable
- Conductor - 18 AWG (7x30) stranded copper (tin plated) 0.010 in. (0.762mm) O.D.
- Insulation - Foamed FEP, 0.015 in. (0.381mm) wall, 0.060 in. (1.524mm) O.D.
- Twist Lay - 2 in. (50.8mm) lay on pair, 6 twists/foot (20 twists/meter) nominal
- Shielding - Aluminum/Mylar shield with 24 AWG (7x32) TC drain
- DC Resistance - 15.2 Ohms/1000 feet (50 Ohms/km) nominal
- Capacitance - 12.5 pF/ft (41 pF/meter) nominal conductor to conductor
- Characteristic Impedance - 100 Ohms

Cable Shields

Do not ground the shield to earth ground or to the control module's power ground. The PROT485 and the individual control modules allow the shield to float a limited amount so that there are no ground loops. If the voltage on the

shield becomes too great relative to the earth ground, then the excess voltage is bled off with protective devices on the PROT485 or on the control modules.

Noise Avoidance

Avoid running communication wires or sensor input wires next to AC power wires or the control module's relay output wires. These can be a source of noise that can affect signal quality. Common sources of noise are:

- | | |
|-------------------------|---------------------------------------|
| Spark ignitors | Induction heaters |
| Radio transmitters | Large contactors (ex. motor starters) |
| Variable speed drives | Video display devices |
| Electric motors (> 1hp) | Lamp dimmers |
| Generators | Fluorescent lights |
| Relays | Parallel runs with power lines |
| Transformers | Other electronic modules |

If noise is a problem and you cannot move the wiring, use ferrite clamp-on chokes on the cabling to improve signal quality.

Wiring Diagram - UCA020, Cooling Only, 208/230v, 460v

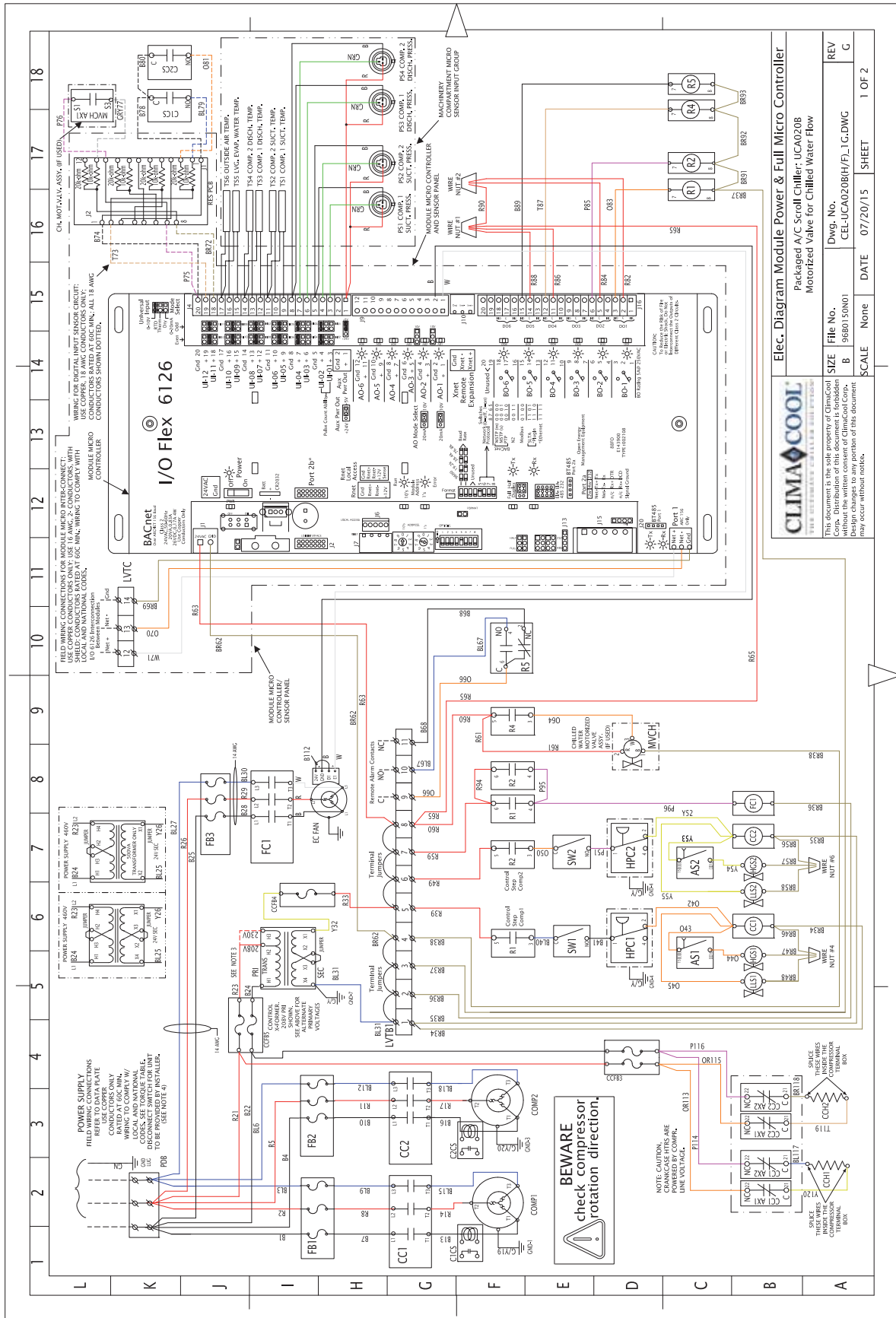

CLIMA-COOL THE ULTIMATE CHILLER SOLUTION		Elec. Diagram Module Power & Full Micro Controller	
Packaged A/C Scroll Chiller: UCA020B		Motorized Valve for Chilled Water Flow	
File No.	SIZE	Dwg. No.	REV
96B0150N01	B	CEL-UCA020B(H)/P_1_G.DWG	G
SCALE	None	DATE	07/20/15
SHEET	1	OF 2	

Wiring Diagram - UCA020, Cooling Only, 208/230v, 460V

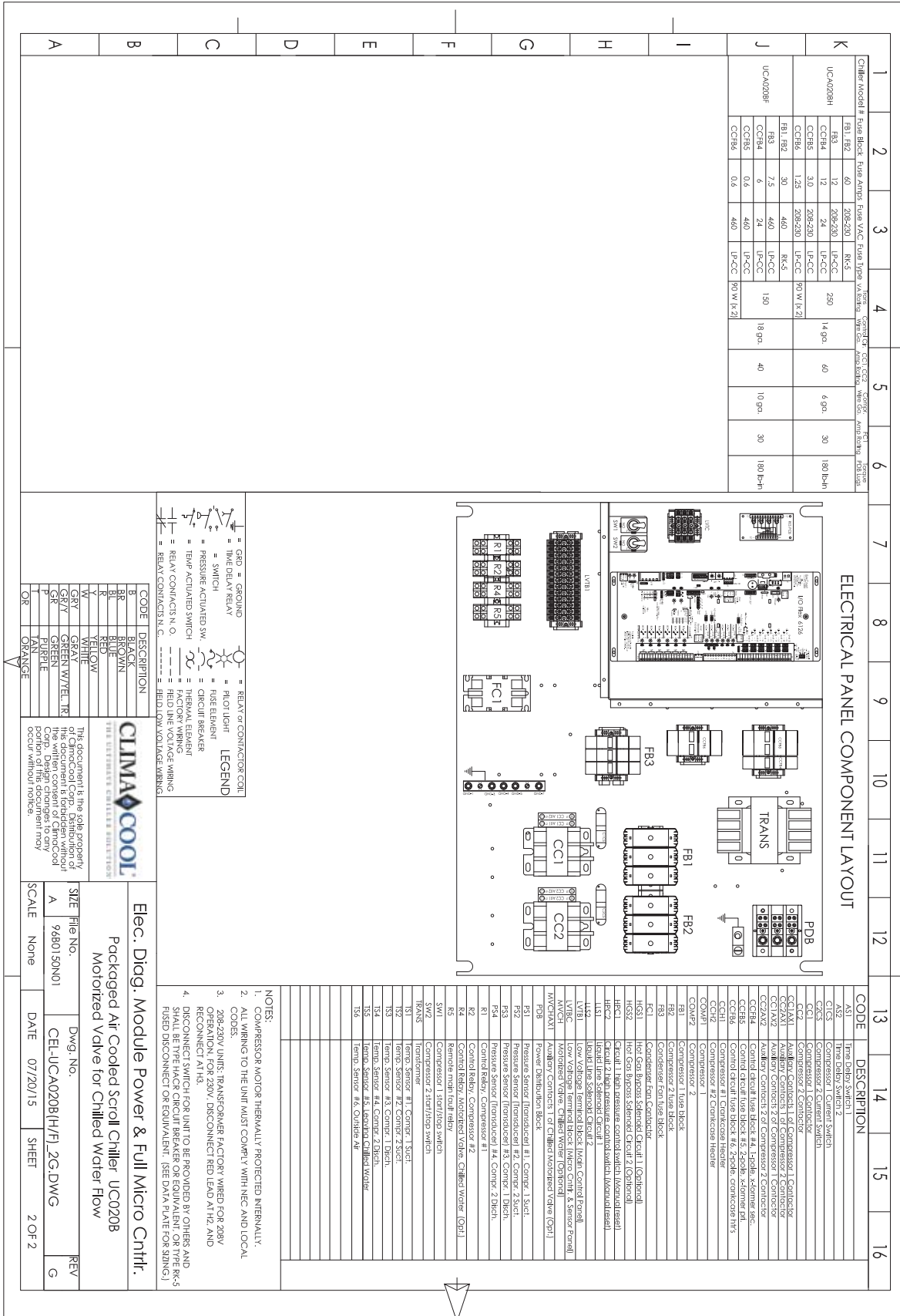

Wiring Diagram - UCA020, HeatPump, 208/230v, 460v

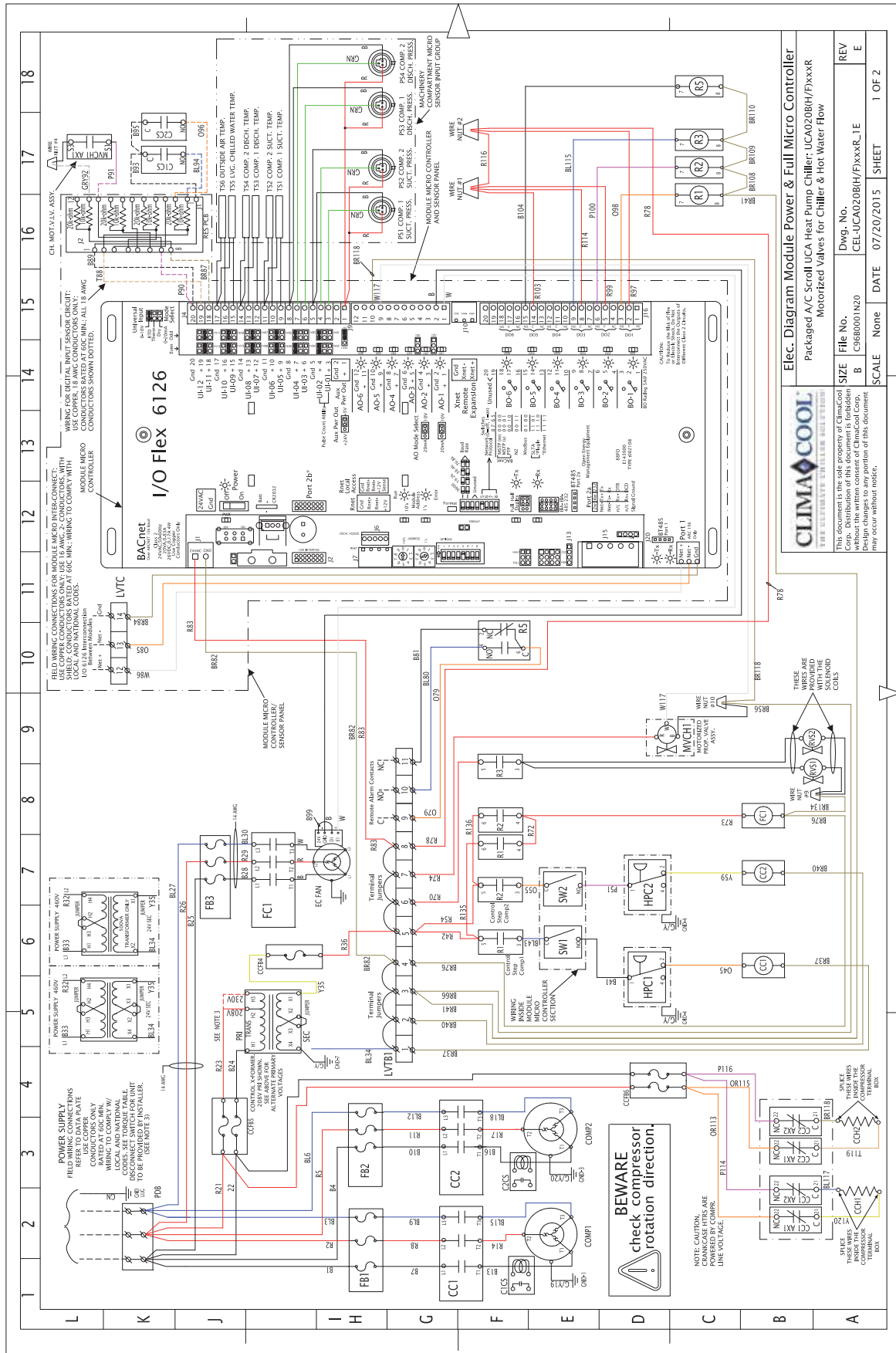

CLIMA-COOL
THE ULTIMATE CHILLER SOLUTION

This document is the sole property of ClimaCool Corp. Distribution of this document is forbidden without the written permission of ClimaCool. All design changes are the property of ClimaCool and may occur without notice.

Elec. Diagram Module Power & Full Micro Controller
Packaged A/C Scroll UCA Heat Pump Chiller: UCA020BH/FxxxR
Motorized Valves for Chiller & Hot Water Flow

Dwg. No. **CEL-UCA020BH/FxxxR-1-E**
File No. **B / C986001R20**
Scale **None**
Date **07/20/2015**
Sheet **1 OF 2**

Wiring Diagram - UCA020, HeatPump, 208/230v, 460v

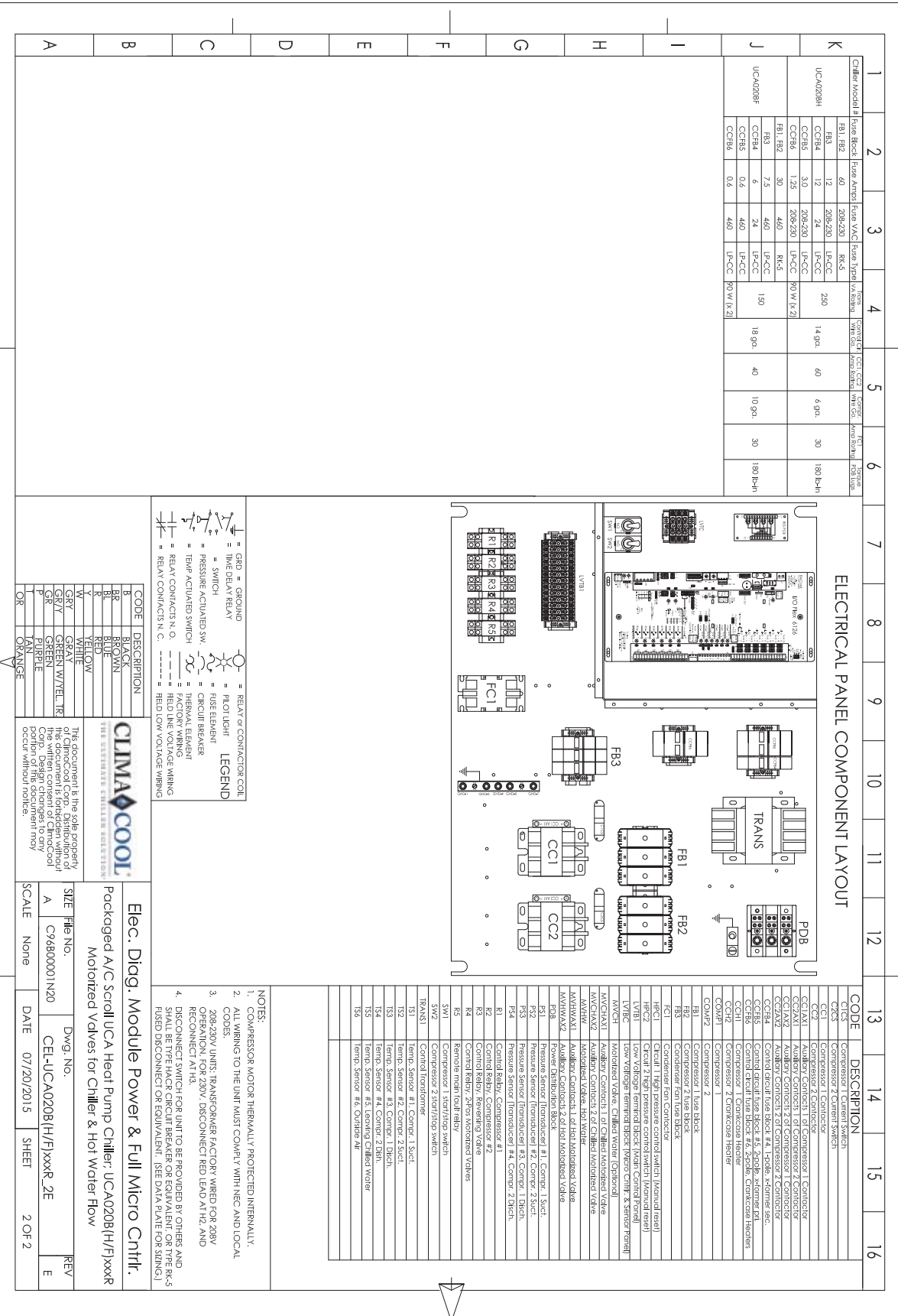

Wiring Diagram - UCA020, Heat Pump, 575V

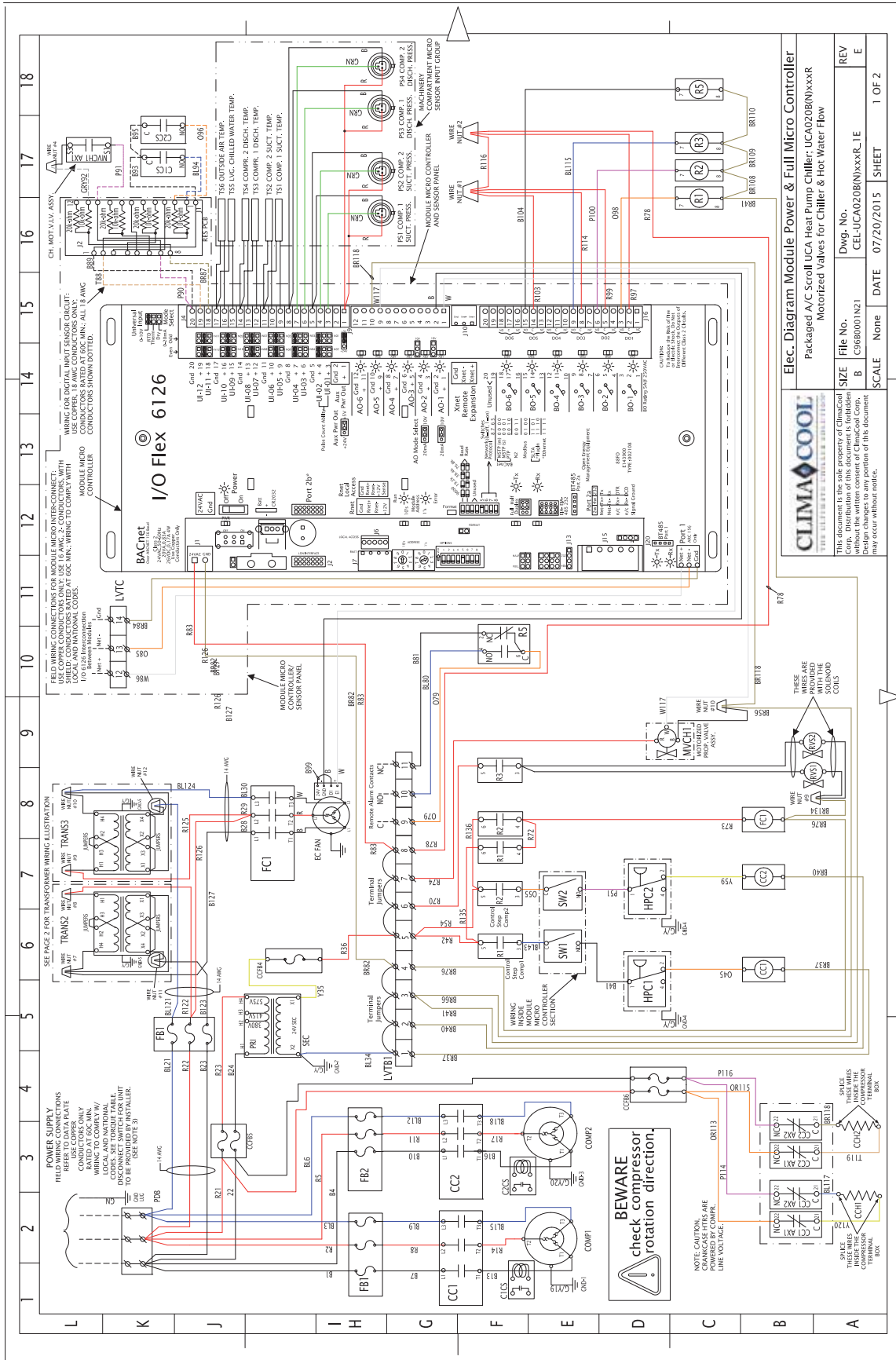

CLIMA-COOL THE ULTIMATE CHILLER SOLUTION		Elec. Diagram Module Power & Full Micro Controller	
This document is the sole property of ClimaCool Corporation. It is to be used only for the project and location specified without the written consent of ClimaCool Corp. Design changes to any portion of this document may occur without notice.		Packaged A/C Scroll UCA Heat Pump Chiller: UCA020B(N)xxxR	
File No.	Dwg. No.	Scale	Rev
C98B0001N21	CEL-UCA020B(N)xxxR_1E	B	E
None	None	None	None
DATE	07/20/2015	SHEET	1 OF 2

Wiring Diagram - UCA020, Heat Pump, 575v

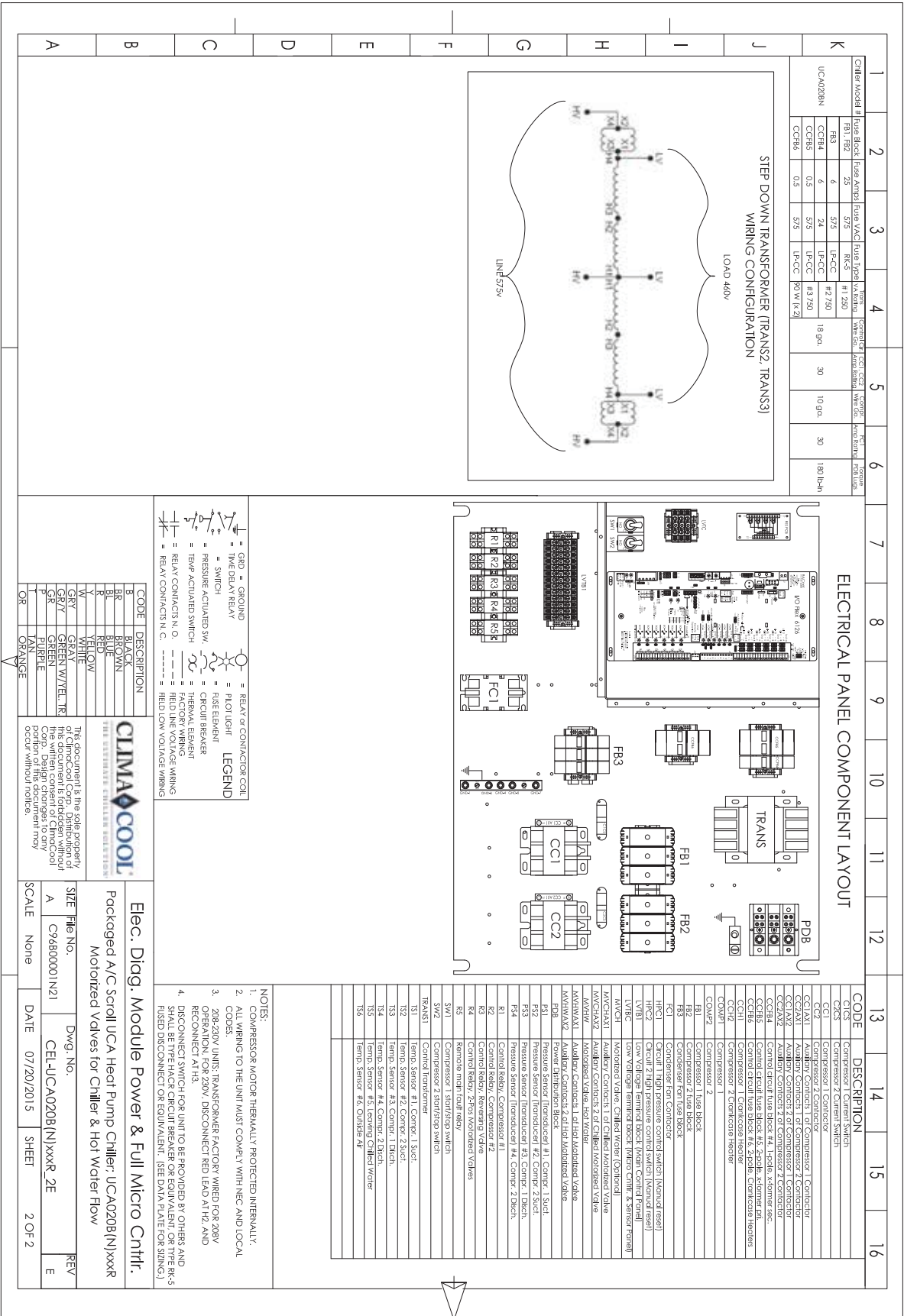

Wiring Diagram - UCA020, SHC Heat Pump, 208/230v, 460v

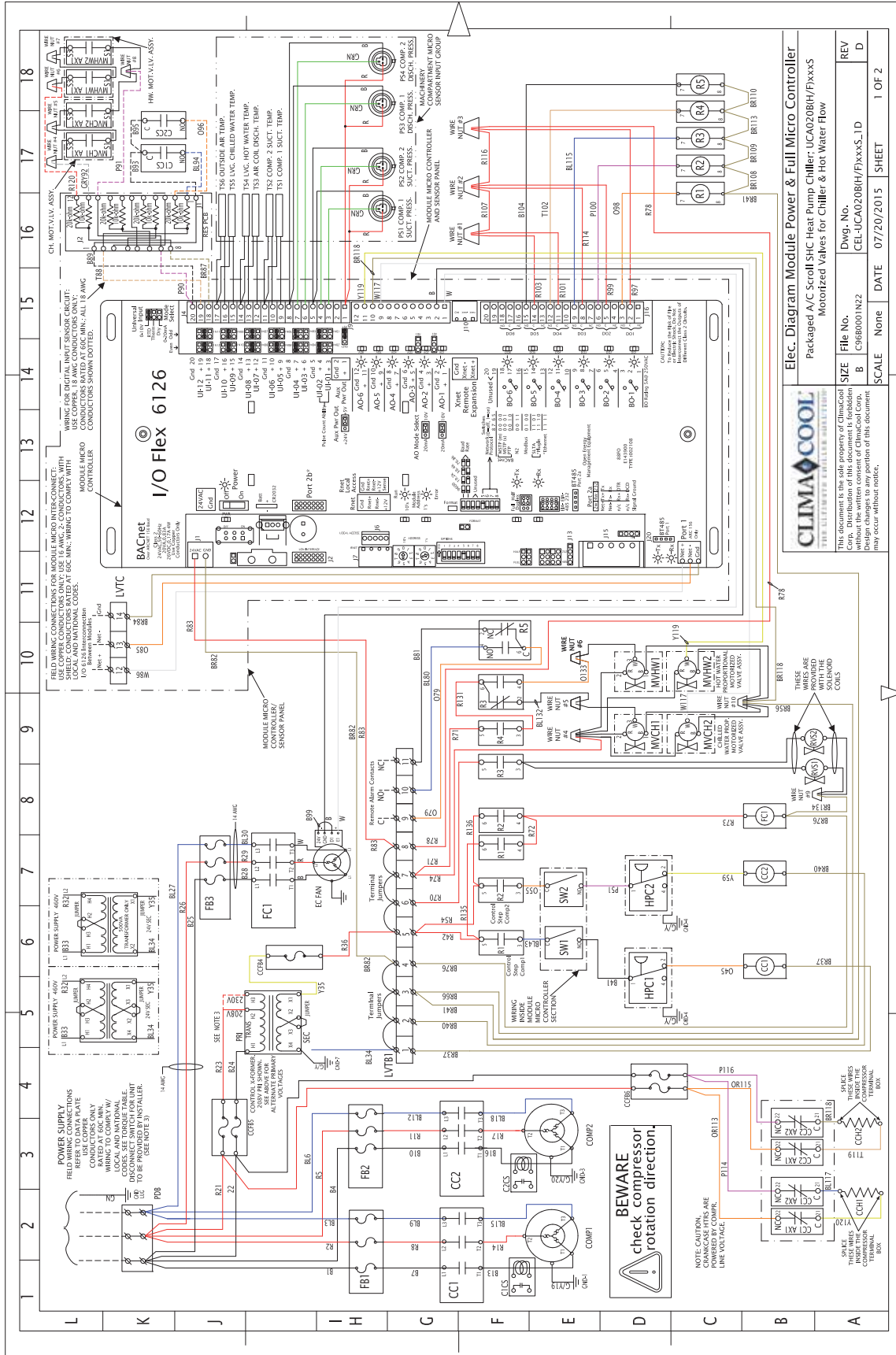

CLIMA-COOL
THE ULTIMATE CHILLER SOLUTION

Elec. Diagram Module Power & Full Micro Controller
Packaged A/C Scroll SHC Heat Pump Chiller: UCA020BH/F/xxxx
Motorized Valves for Chiller & Hot Water Flow

File No. UCA020BH/F/xxxx
Size B
Dwg. No. CE-UCA020BH/F/xxxx_ID
REV D

SCALE None DATE 07/20/2015 SHEET 1 OF 2

This document is the sole property of Climacoil Corp. Distribution of this document is forbidden. Design changes to any portion of this document may occur without notice.

Wiring Diagram - UCA020, SHC Heat Pump, 208/230v, 460v

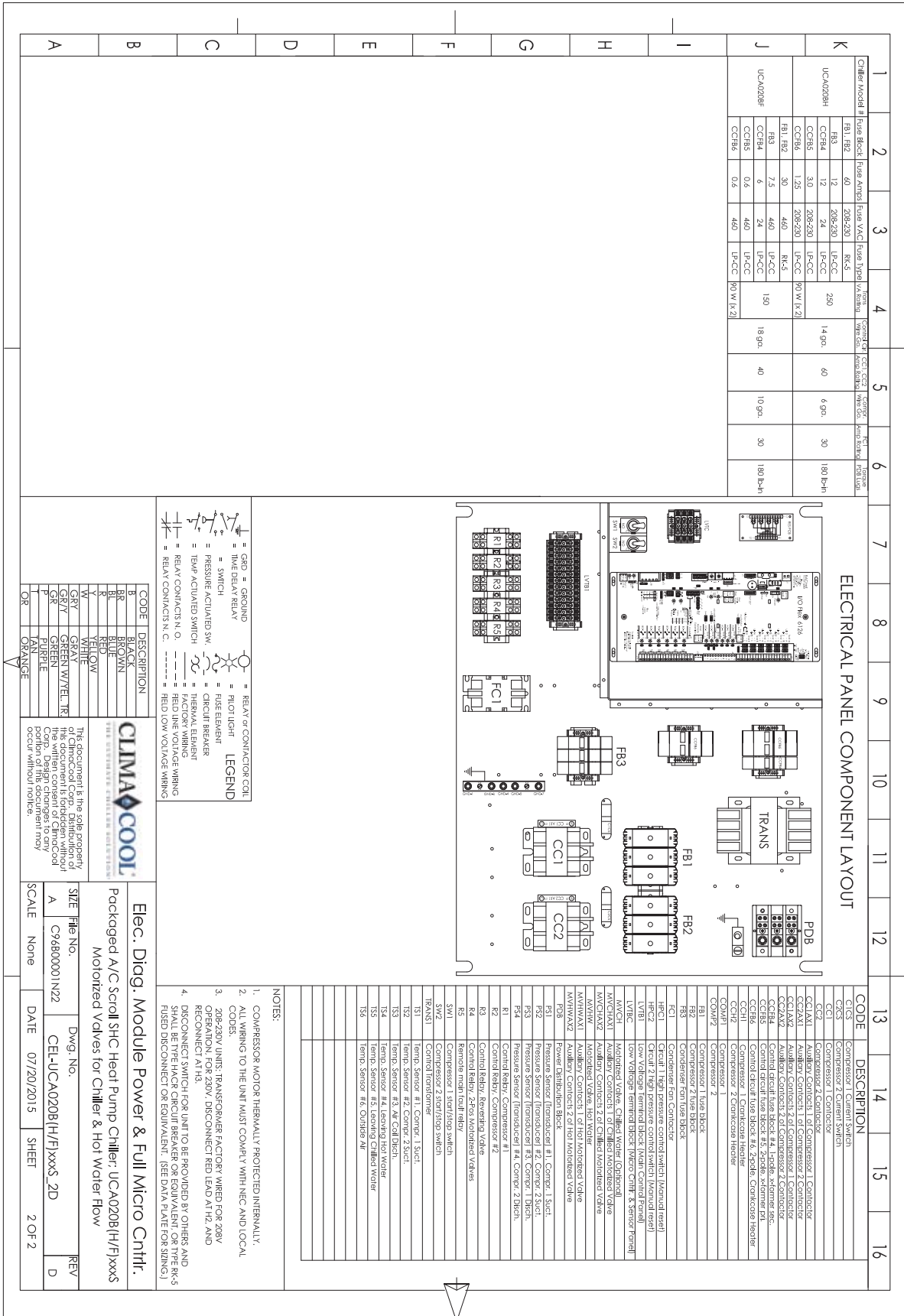

Wiring Diagram - UCA030, Cooling Only, 208/230v, 460v

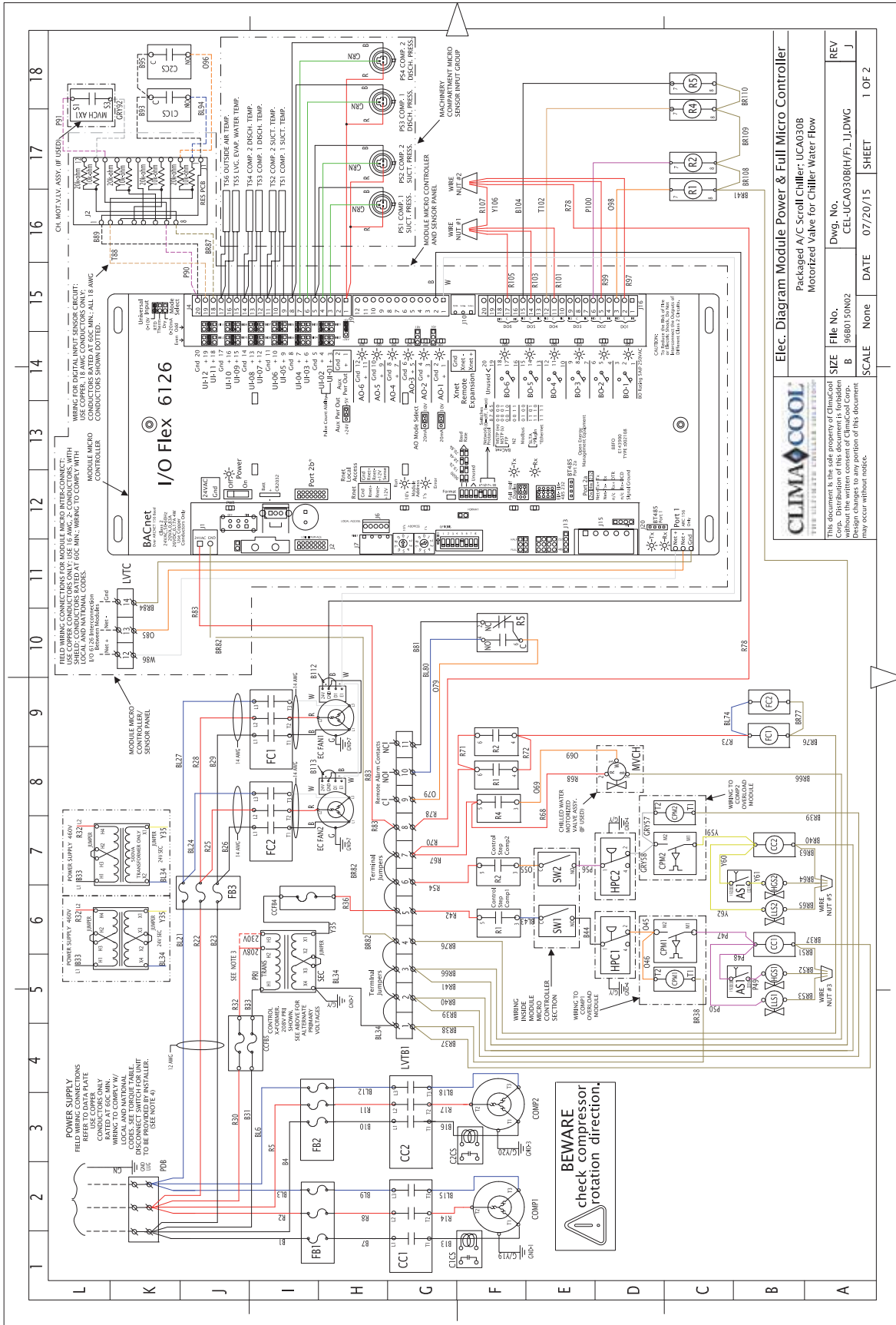

CLIMA COOL
THE ULTIMATE CHILLER SOLUTION

This document is the sole property of ClimaCool Corp. Distribution of this document is forbidden without the written consent of ClimaCool Corp. Any reproduction or translation of this document may occur without notice.

Elec. Diagram Module Power & Full Micro Controller
Packaged A/C Scroll Chiller: UCA030B
Motorized Valve for Chiller: Water Flow

SIZE	File No.	Dwg. No.	REV
B	9680150002	CEL-UCA030B(F/L)_LDWG	J

SCALE None DATE 07/20/15 SHEET 1 OF 2

Wiring Diagram - UCA030, Cooling Only, 208/230v, 460v

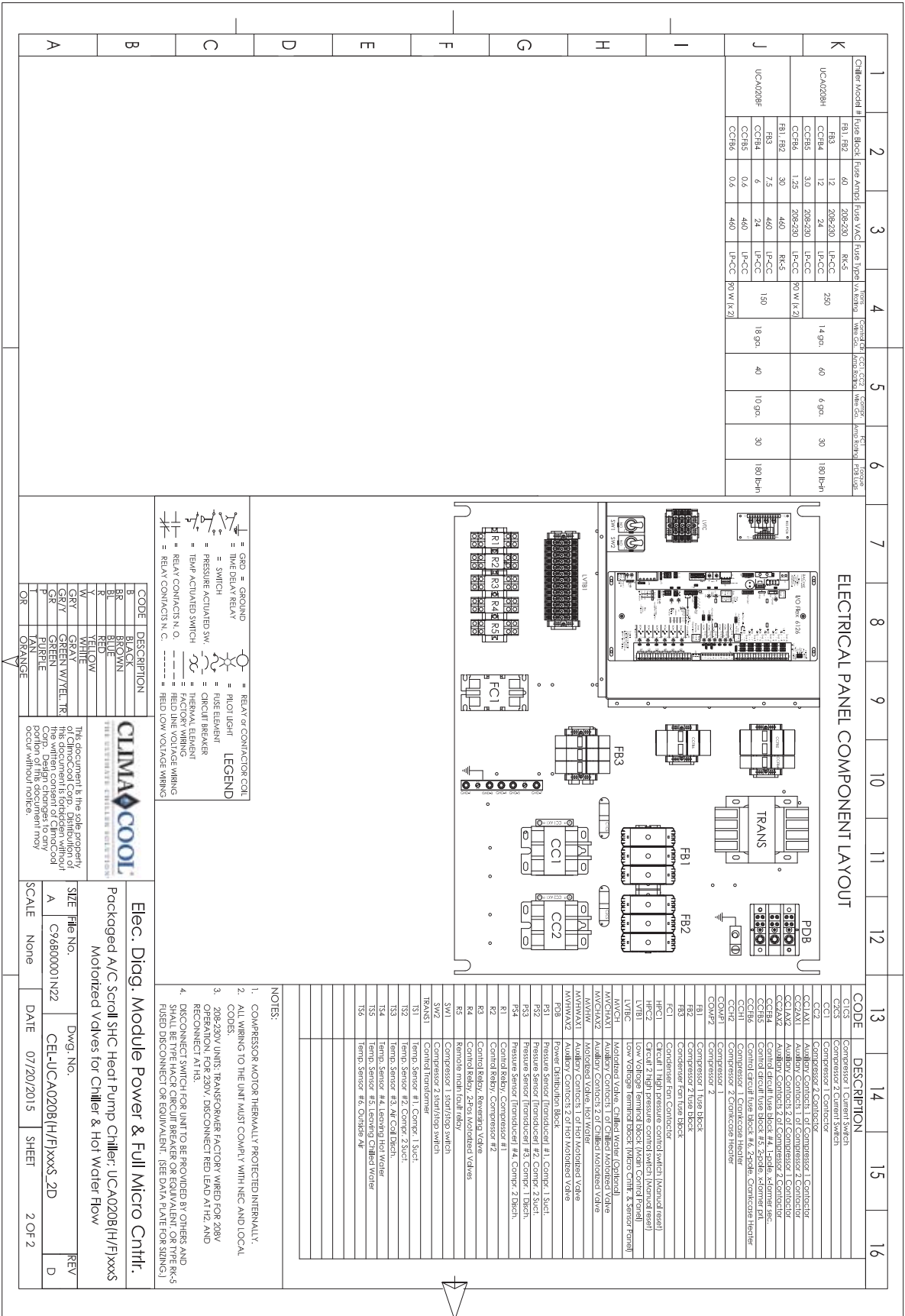

Wiring Diagram - UCA030, Cooling Only, 575v

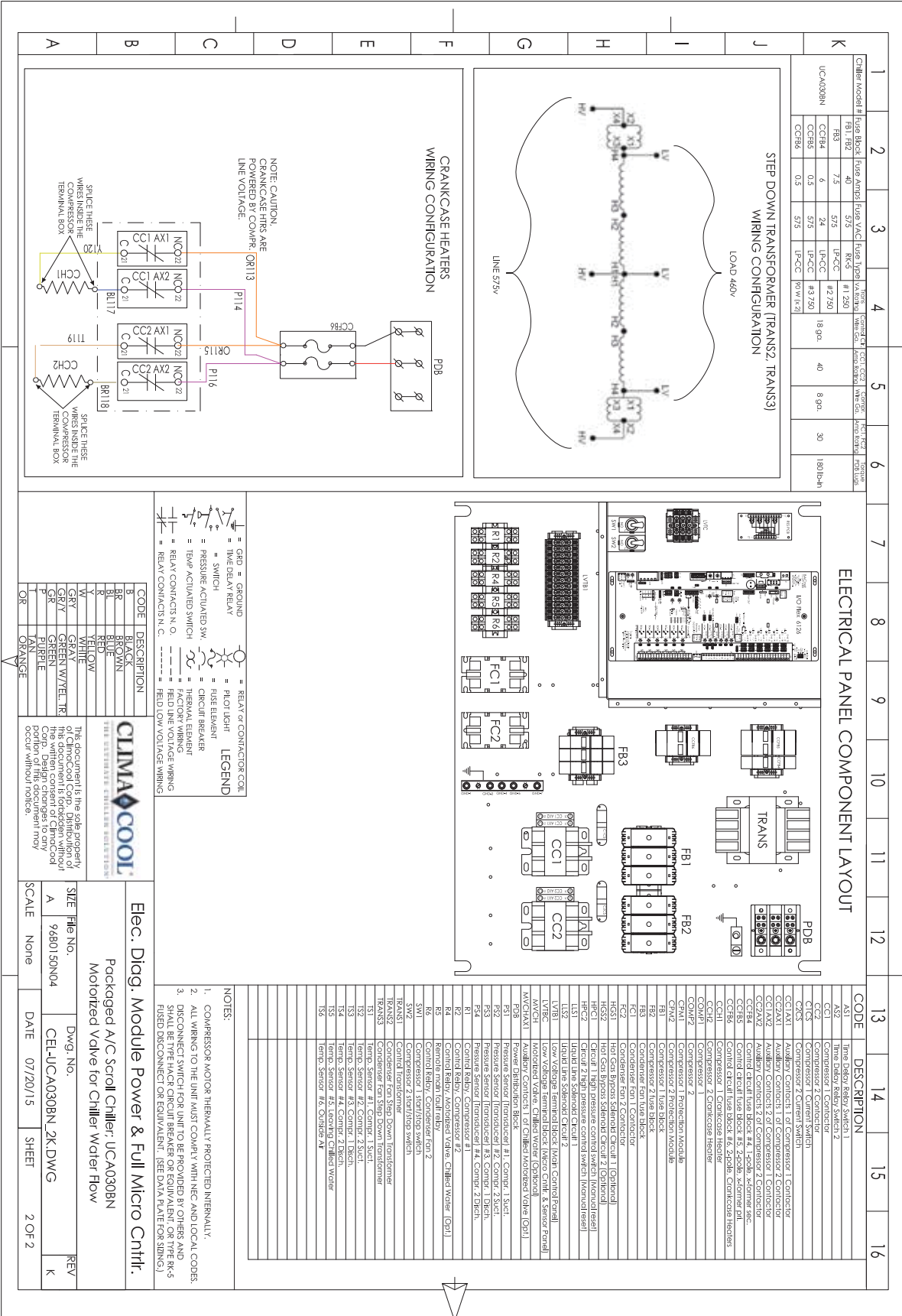

Wiring Diagram - UCA030, Heat Pump, 208/230v, 460v

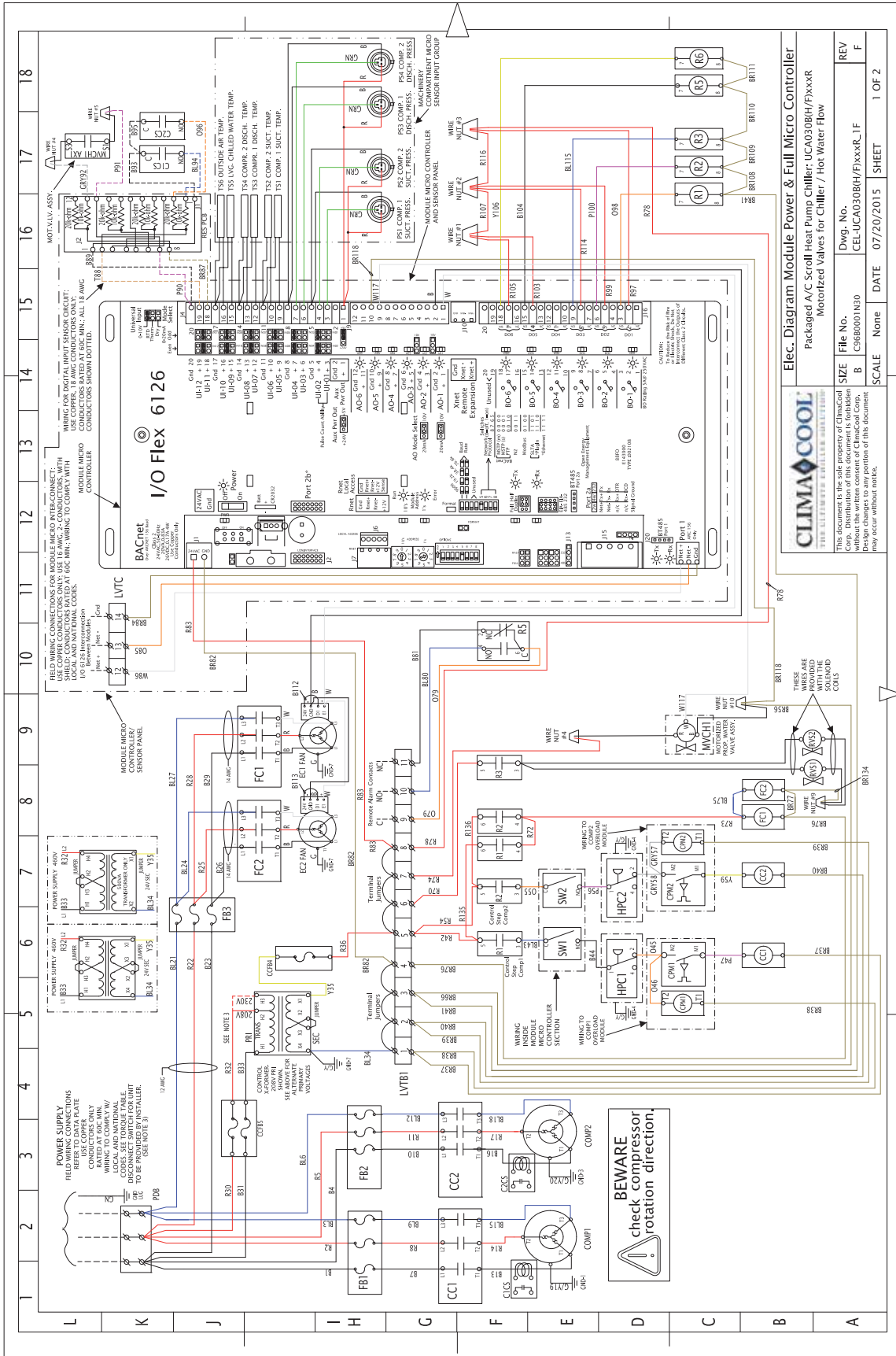

CLIMA-COOL
 THE ULTIMATE CHILLER SOLUTION[®]

THIS DOCUMENT IS THE PROPERTY OF CLIMA-COOL CORPORATION. IT IS TO BE USED ONLY FOR THE PROJECT AND WITHOUT THE WRITTEN CONSENT OF CLIMA-COOL CORP. Design changes to any portion of this document may occur without notice.

Elec. Diagram Module Power & Full Micro Controller
 Packaged A/C Scroll Heat Pump Chiller: UCA030BH/FXxxx
 Motorized Valves for Chiller / Hot Water Flow

File No.	Dwg. No.	REV
C96B001N30	CEL-UCA030BH/FXxxxR1_F	F
SCALE	None	DATE
		07/20/2015
		SHEET
		1 OF 2

Wiring Diagram - UCA030, Heat Pump, 208/230v, 460v

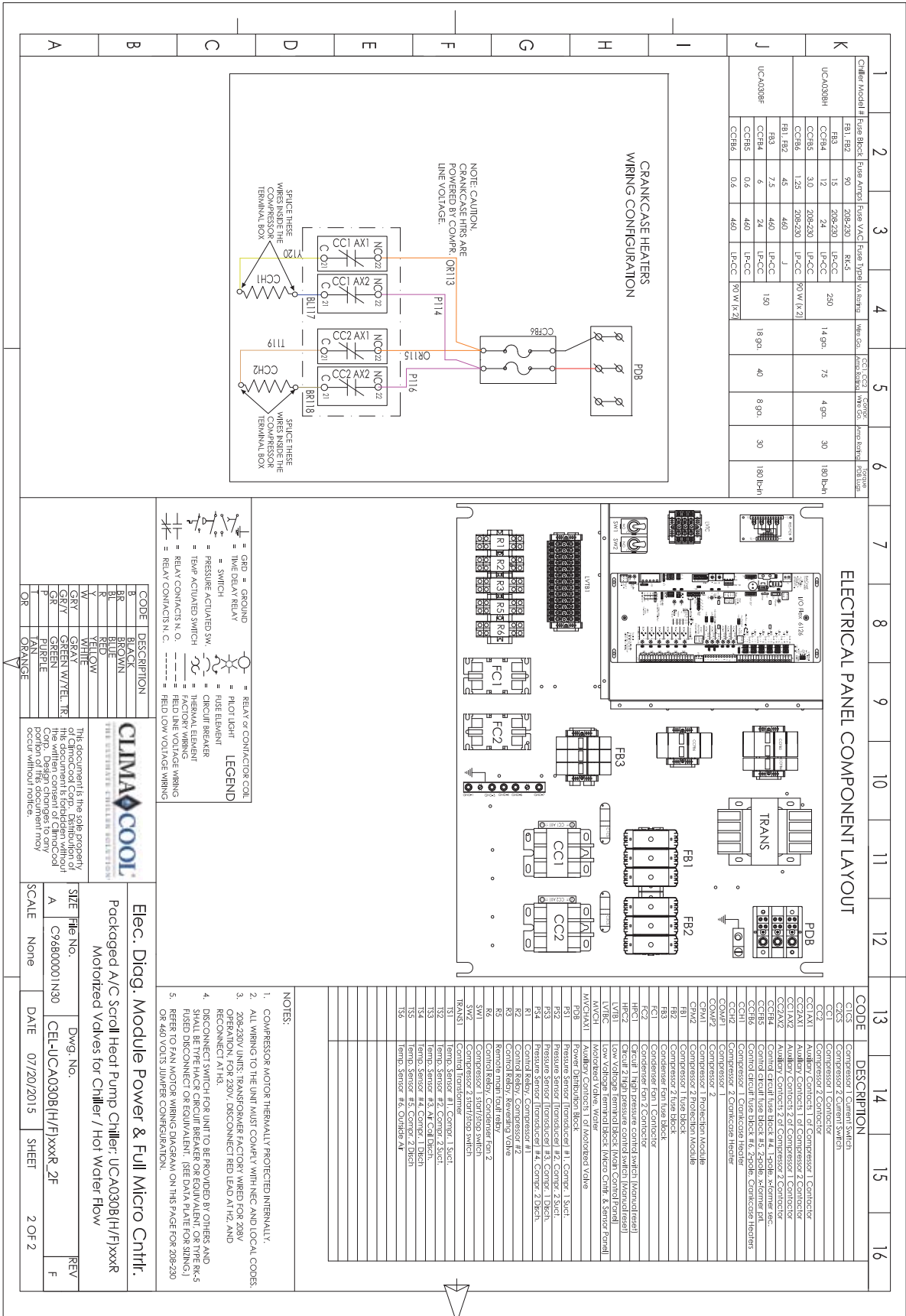

Wiring Diagram - UCA030, Heat Pump, 575V

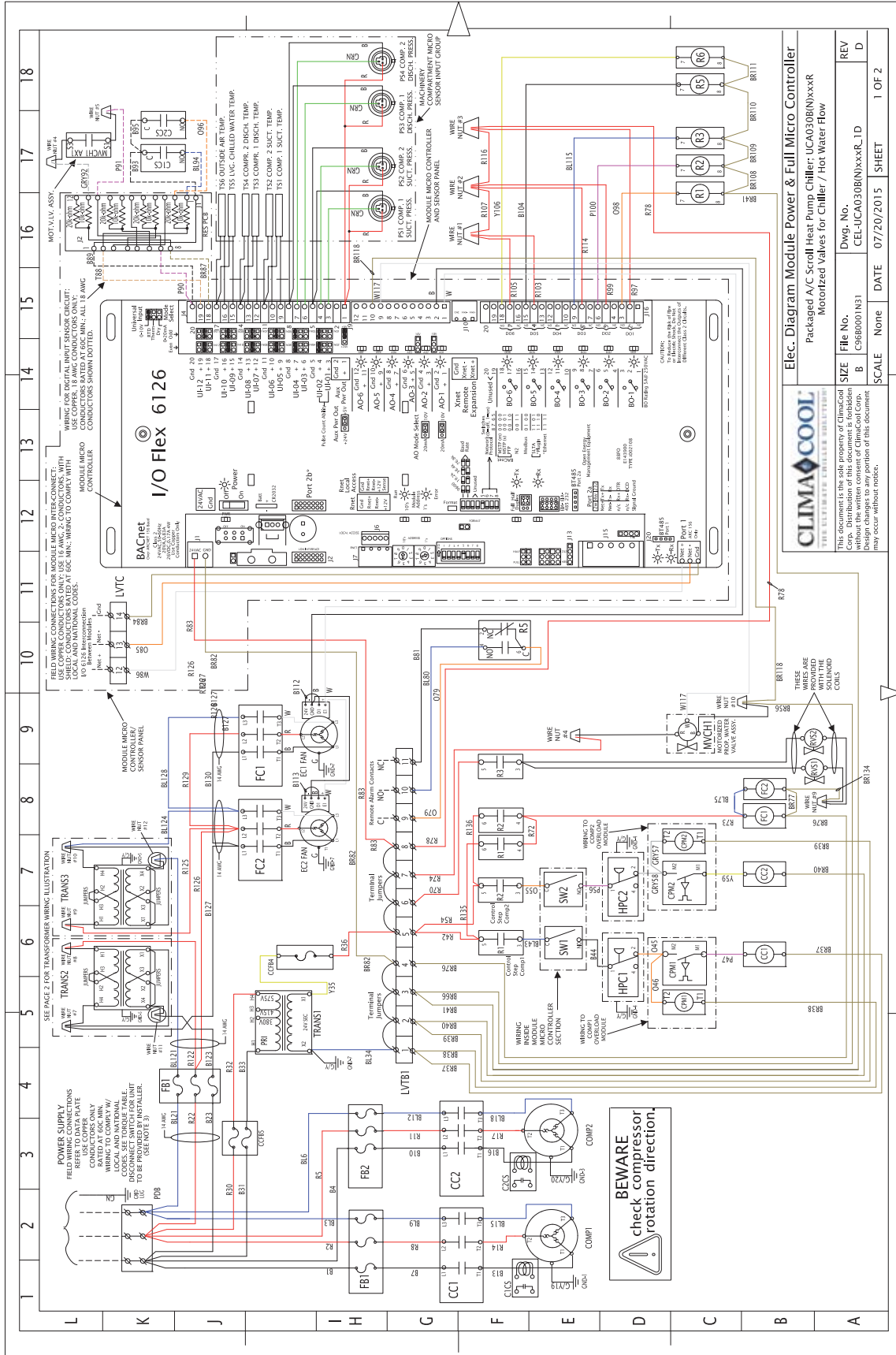

Wiring Diagram - UCA030, Heat Pump, 575v

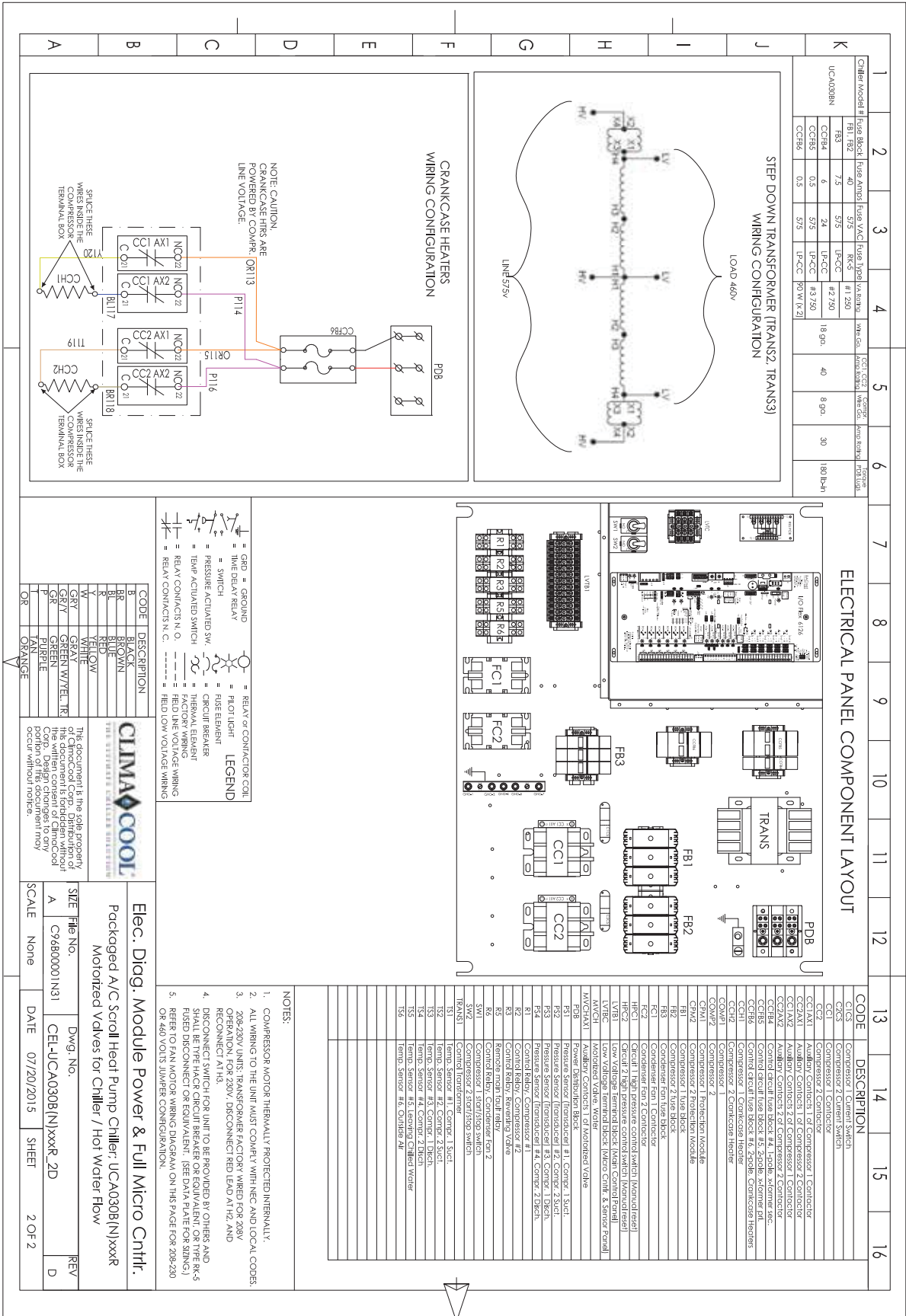

Wiring Diagram - UCA030, SHC Heat Pump, 208/230v, 460v

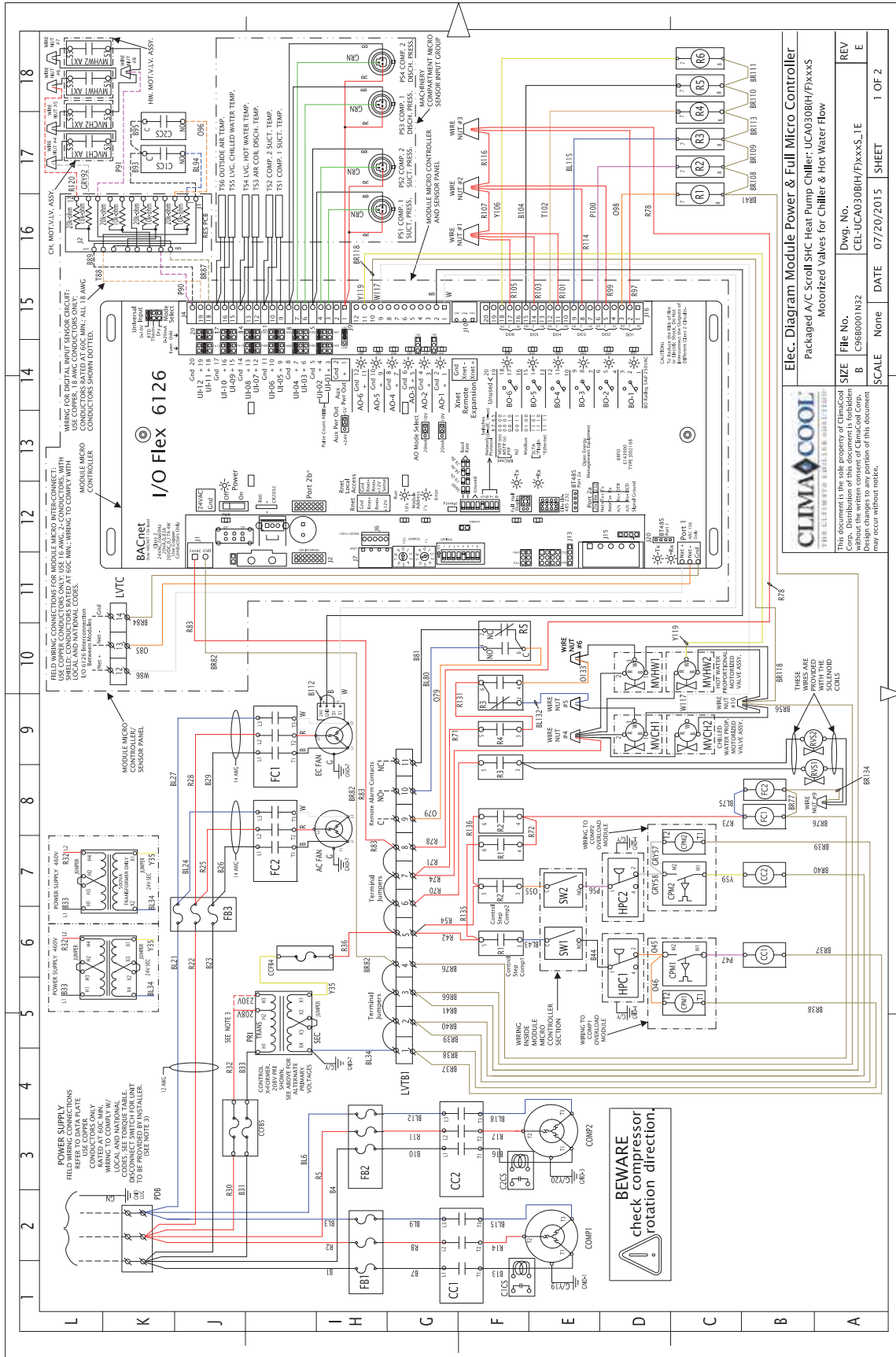

		Elec. Diagram Module Power & Full Micro Controller Packaged A/C Scroll SHC Heat Pump Chiller: UCA030BH/FXxxx Motorized Valves for Chiller & Hot Water Flow	
This document is the sole property of Climacoil and shall remain confidential without the written consent of Climacoil Corp. Design changes to any portion of this document may occur without notice.	Dwg. No. CEL-UCA030BH/FXxxx_1E	File No. B C9680001N32	REV E
SCALE	None	DATE	07/20/2015
SHEET	1	OF 2	

Wiring Diagram - UCA030, SHC Heat Pump, 208/230v, 460v

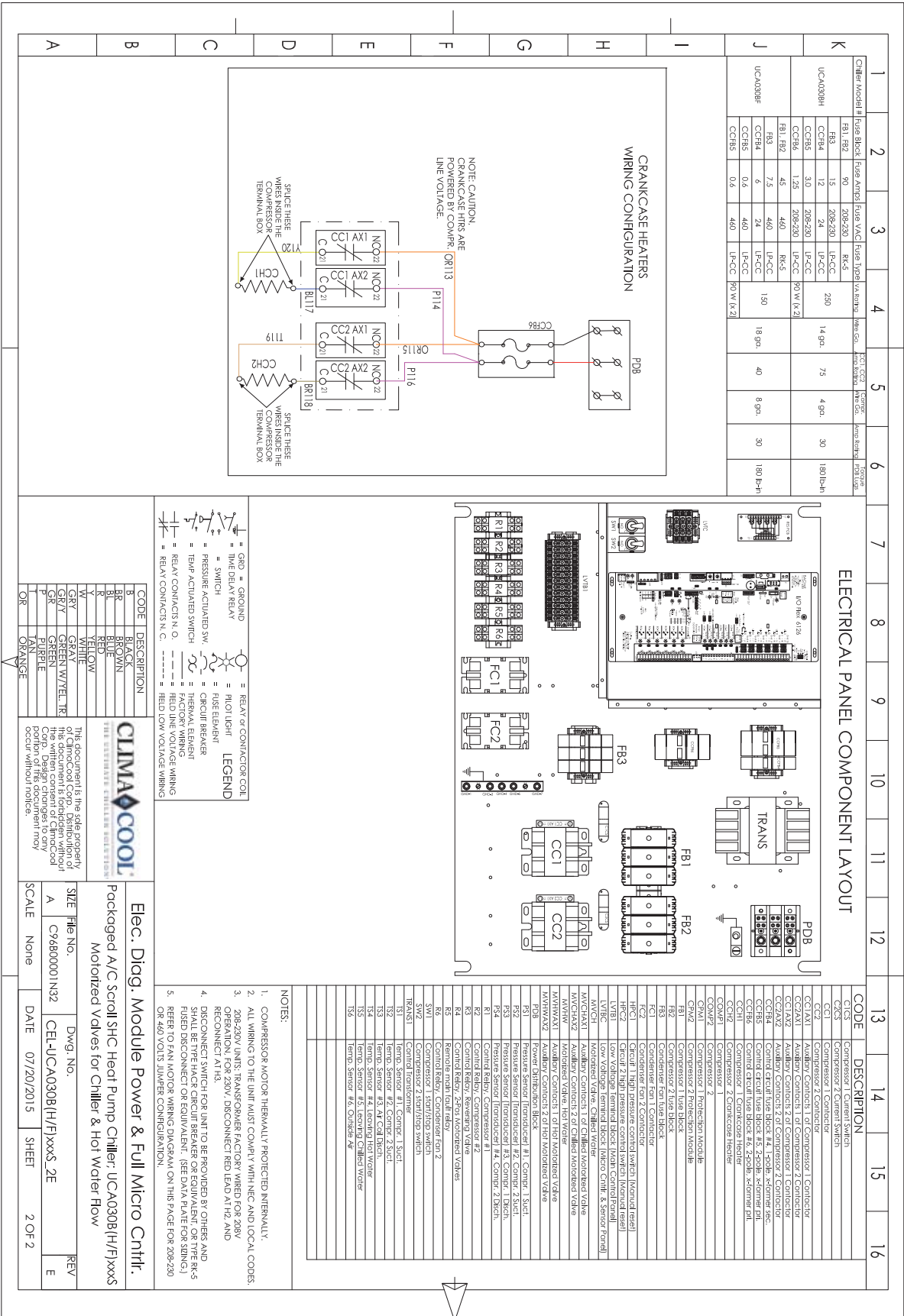

Wiring Diagram - UCA030, SHC Heat Pump, 575v

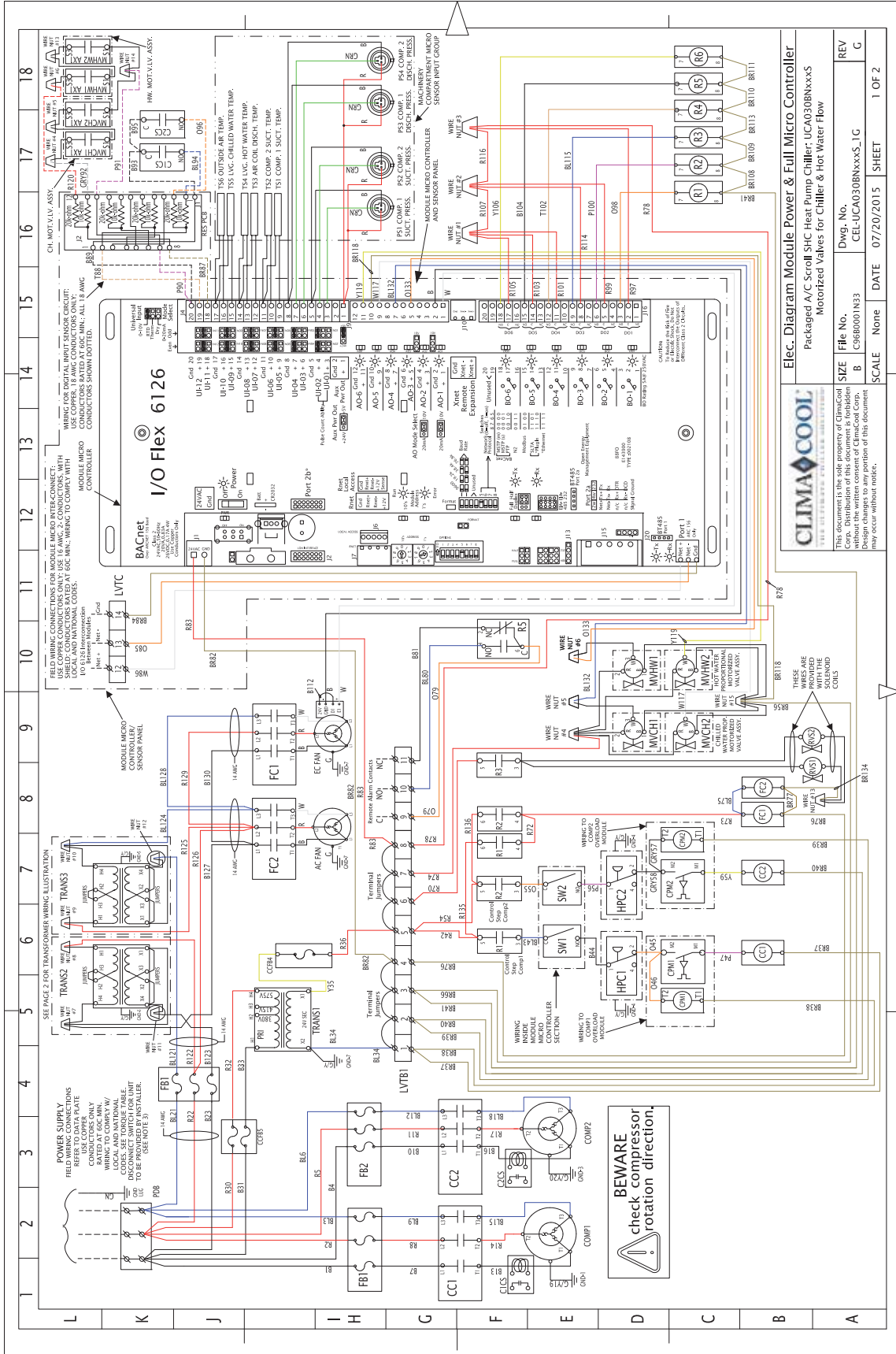

CLIMA-COOL
THE ULTIMATE CHILLER SOLUTION[®]

Elec. Diagram Module Power & Full Micro Controller
Packaged A/C Scroll SHC Heat Pump Chiller: UCA030BNxxxx
Motorized Valves for Chiller & Hot Water Flow

This document is the sole property of Climacool Corp. Distribution of this document is prohibited. Design changes to any portion of this document may occur without notice.

File No. C9860001N33
SIZE B
SCALE 1 OF 2
DATE 07/20/2015
SHEET 1 OF 2
REV G

Dwg. No. CEE-UCA030BNxxxx_1G

Wiring Diagram - UCA030, SHC Heat Pump, 575v

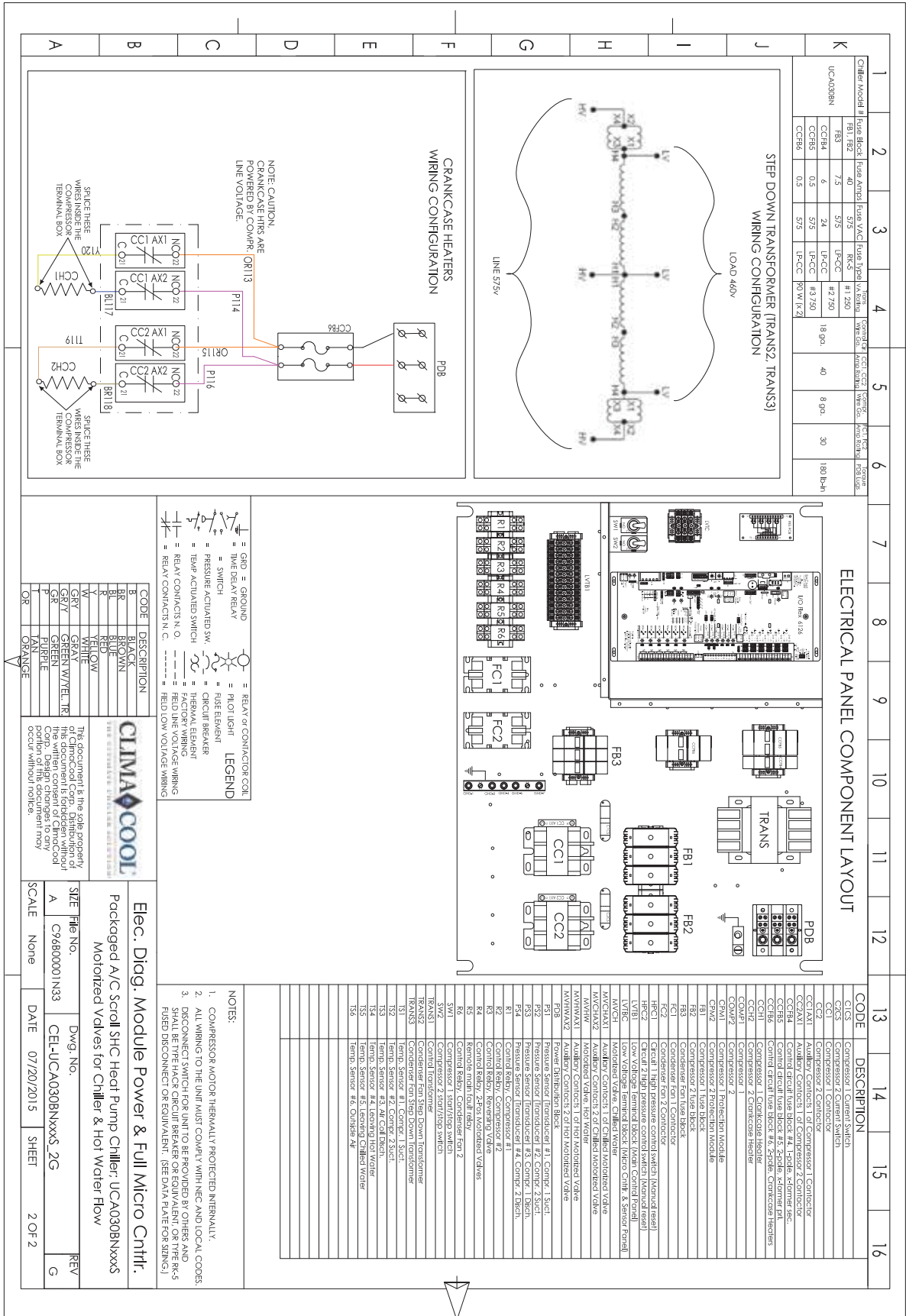

Wiring Diagram - UCF030, Free Cooling, 208/230v , 460v

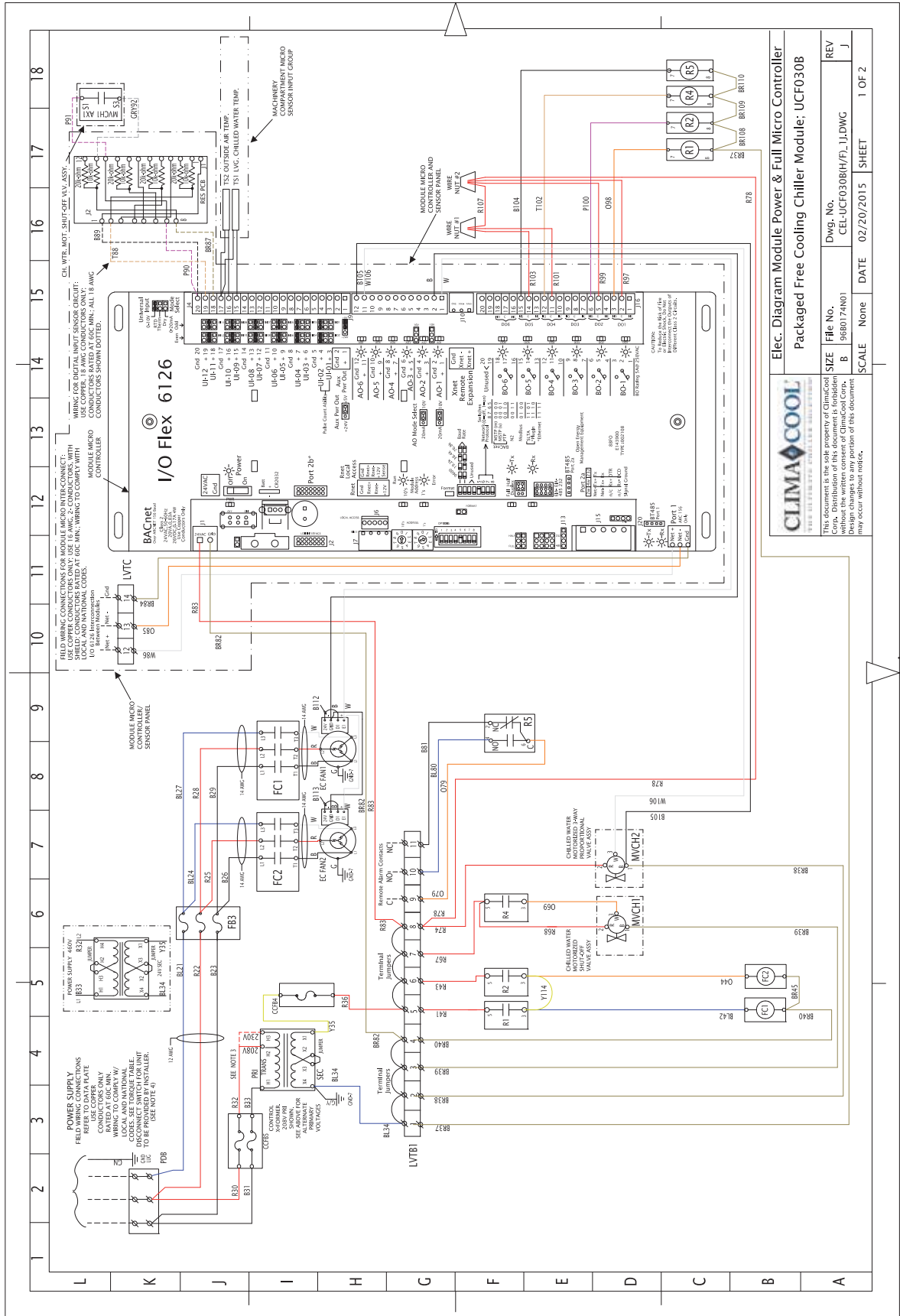

Elec. Diagram Module Power & Full Micro Controller	
Packaged Free Cooling Chiller Module: UCF030B	
CLIMA-COOL	FILE NO. 9680174N01
SIZE B	DWG. NO. CEI-UCF030BH(F)-J.DWG
SCALE None	REV J
DATE 02/20/2015	SHEET 1 OF 2

This document is the sole property of ClimaCool and shall not be reproduced, copied, or disseminated without the written consent of ClimaCool Corp. Design changes to any portion of this document may occur without notice.

Wiring Diagram - UCF030, Free Cooling, 208/230v, 460v

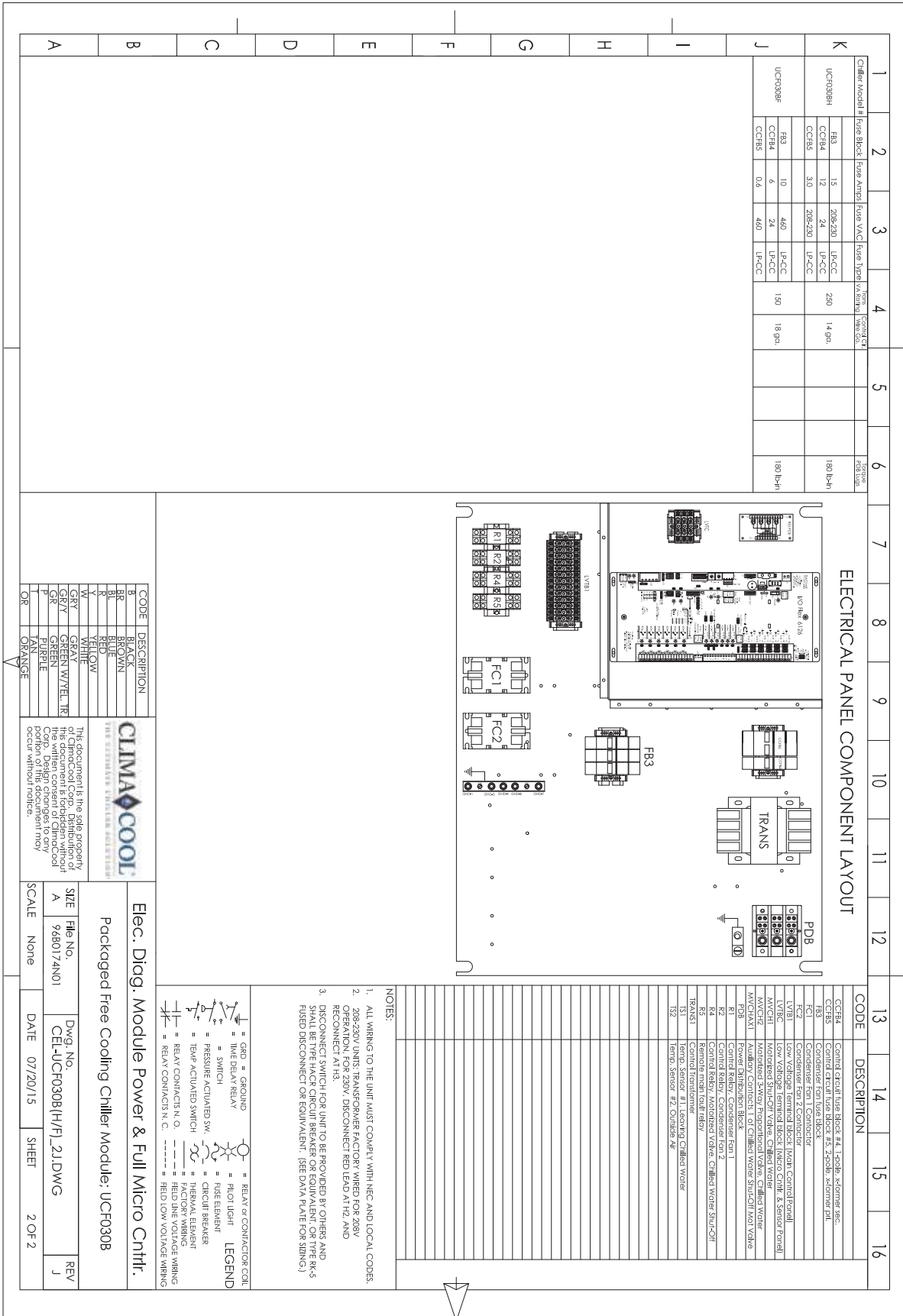

Wiring Diagram - UCF030, Free Cooling, 575v

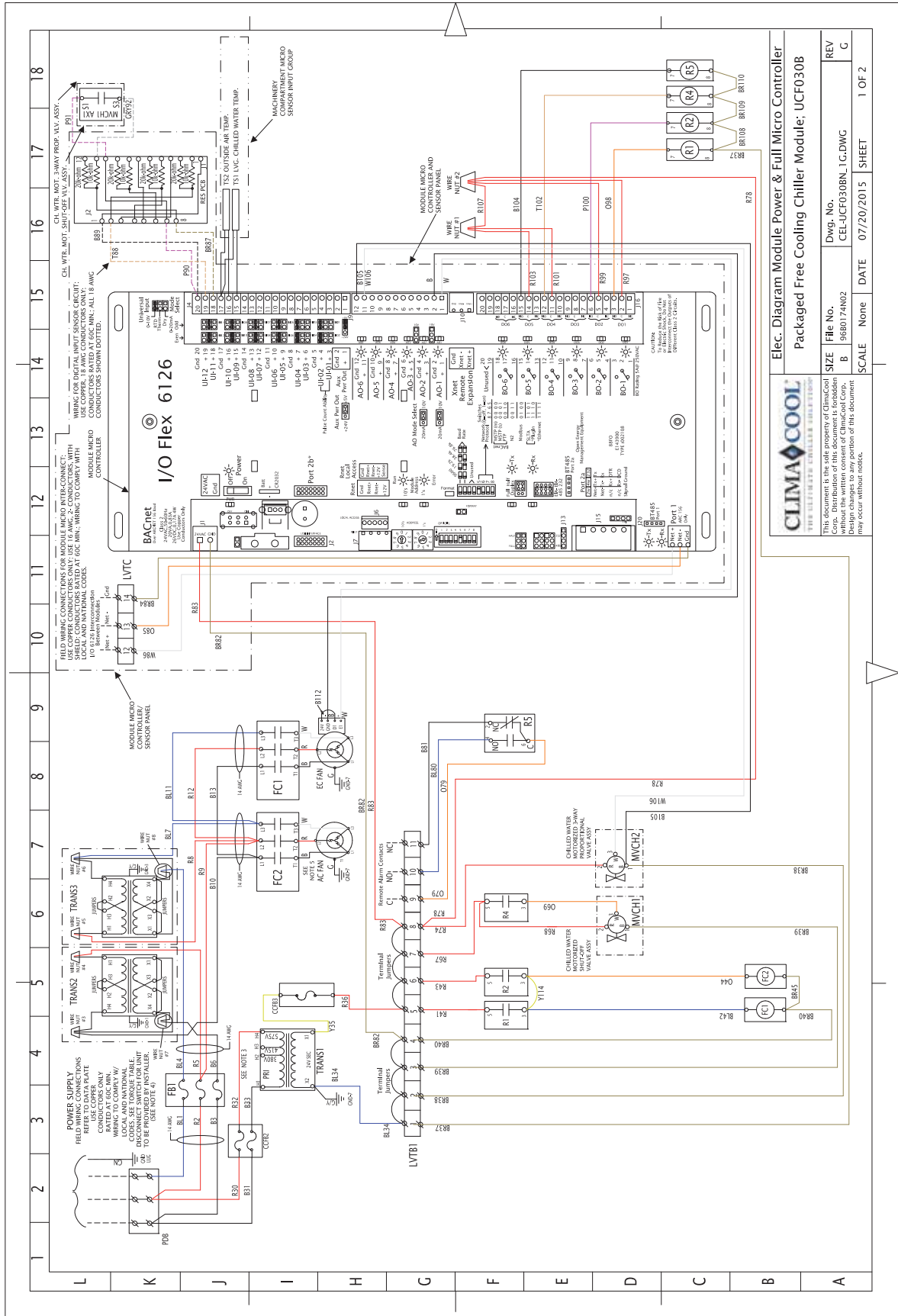

CLIMA-COOL
 THE ULTIMATE CHILLER SOLUTION

Elec. Diagram Module Power & Full Micro Controller
Packaged Free Cooling Chiller Module: UCF030B

This document is the sole property of ClimaCool and is not to be reproduced, stored in a retrieval system, or transmitted in any form or by any means, without the written consent of ClimaCool Corp. Design changes to any portion of this document may occur without notice.

REV	G
FILE NO.	CEL-UCF030BN.1.G.DWG
DWG. NO.	9680174N02
SCALE	None
DATE	07/20/2015
SHEET	1 OF 2

Wiring Diagram - UCF030, Free Cooling, 575v

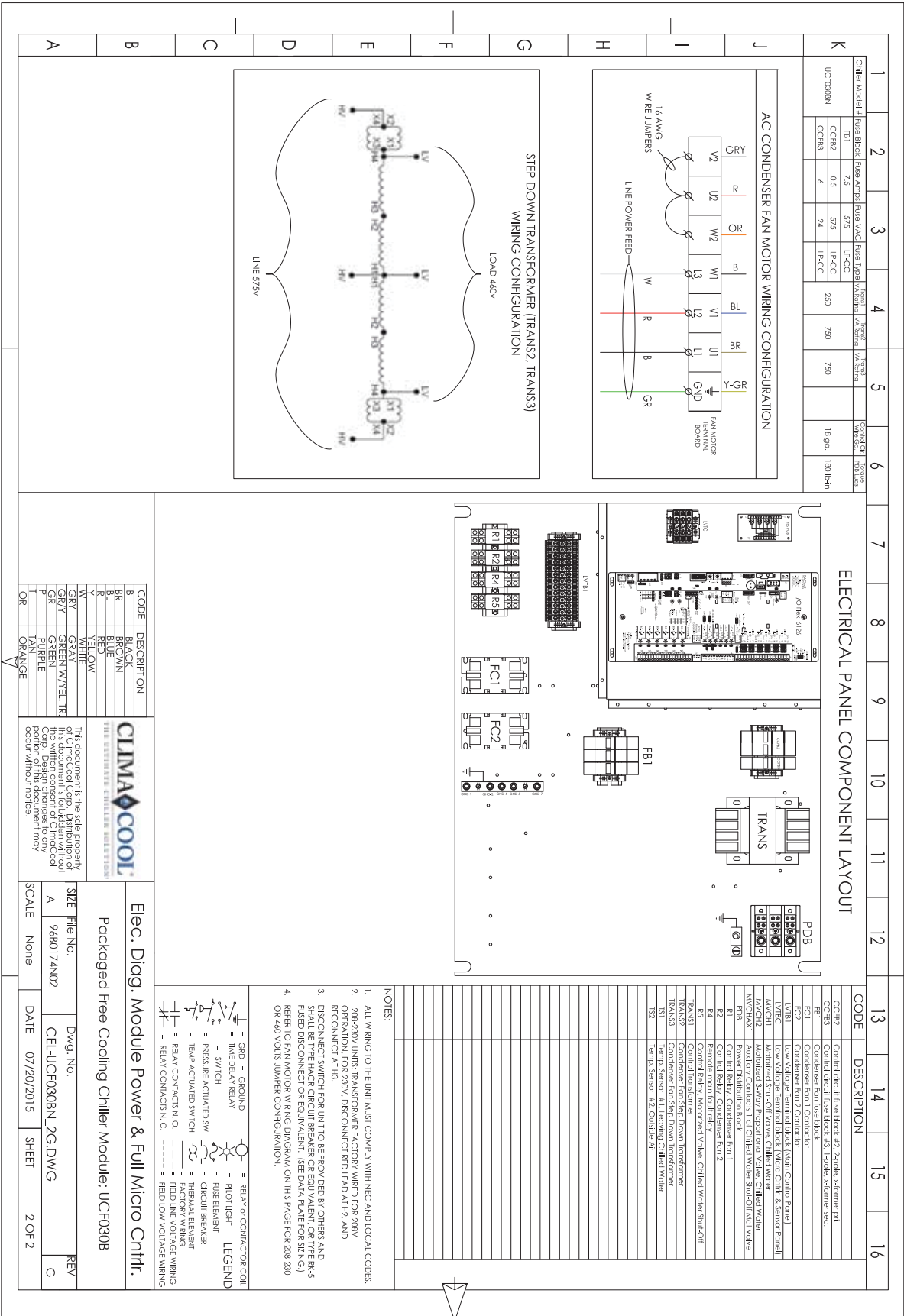

Wiring Diagrams - UCA070, Cooling Only, 208/230v, 460v

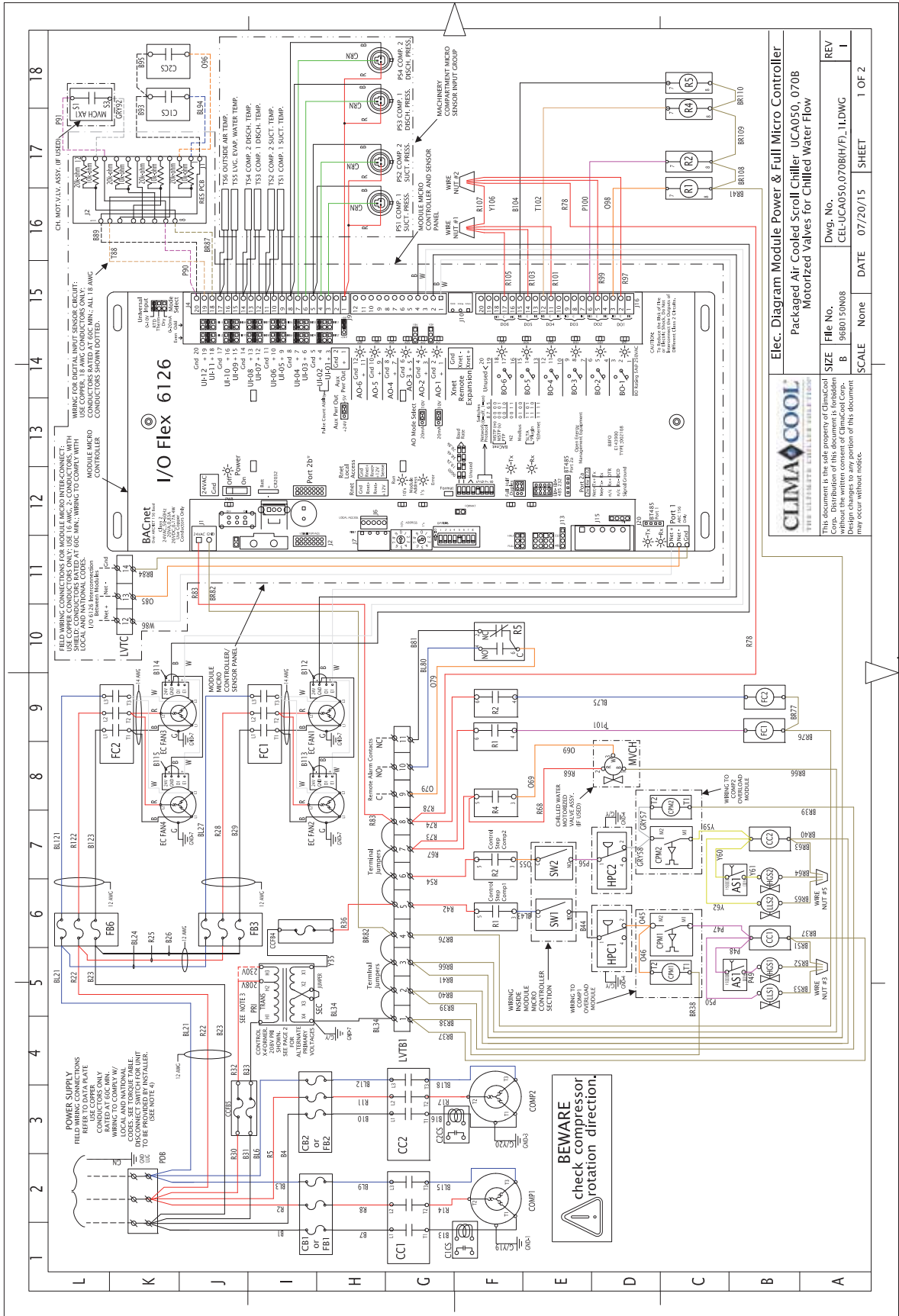

CLIMA-COOL THE ULTIMATE CHILLER SOLUTION [®]		Elec. Diagram Module Power & Full Micro Controller	
Packaged Air Cooled Scroll Chiller UCA050_0708		Motorized Valves for Chilled Water Flow	
FILE NO.	SIZE	DWG. NO.	REV
96B0150N08	B	CEL-UCA050.0708R(F)_1LDWG	I
SCALE	None	DATE	07/20/15
SHEET	1	OF 2	

Wiring Diagrams - Master Control Panel

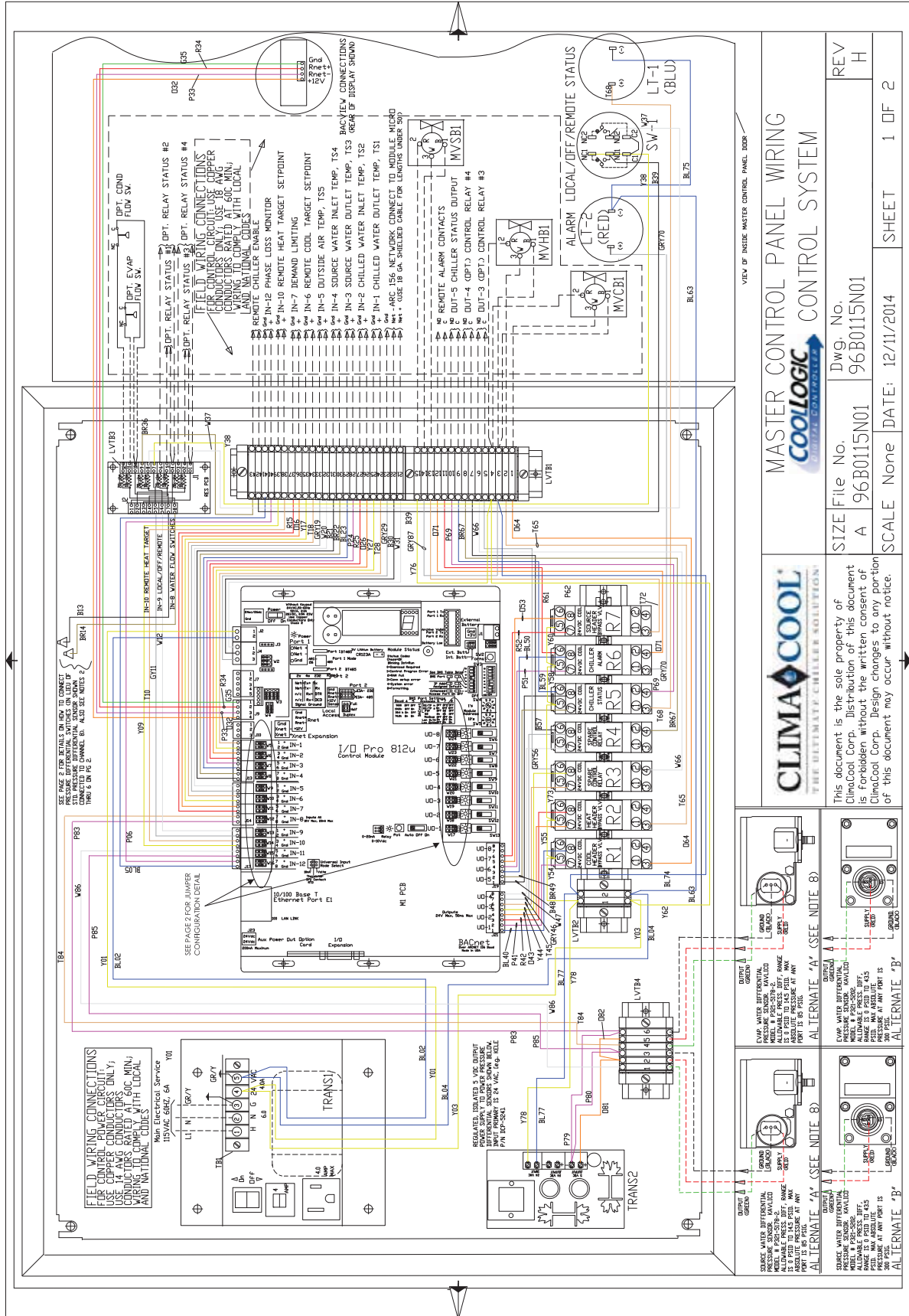

VIEW OF INSIDE MASTER CONTROL PANEL (RIB)

CLIMA-COOL
THE ULTIMATE CHILLER SOLUTION!

MASTER CONTROL PANEL WIRING
COOLLOGIC
CONTROL SYSTEM

REV H
Dwg. No. 96.B0115N01

SIZE File No. 96.B0115N01

SCALE None

DATE: 12/11/2014

CLIMA-COOL
THE ULTIMATE CHILLER SOLUTION!

This document is the sole property of ClimaCool Corp. Distribution of this document is forbidden without the written consent of ClimaCool Corp. Design changes to any portion of this document may occur without notice.

ALTERNATE 'A' (SEE NOTE B)

SHEET 1 OF 2

Wiring Diagrams - Master Control Panel

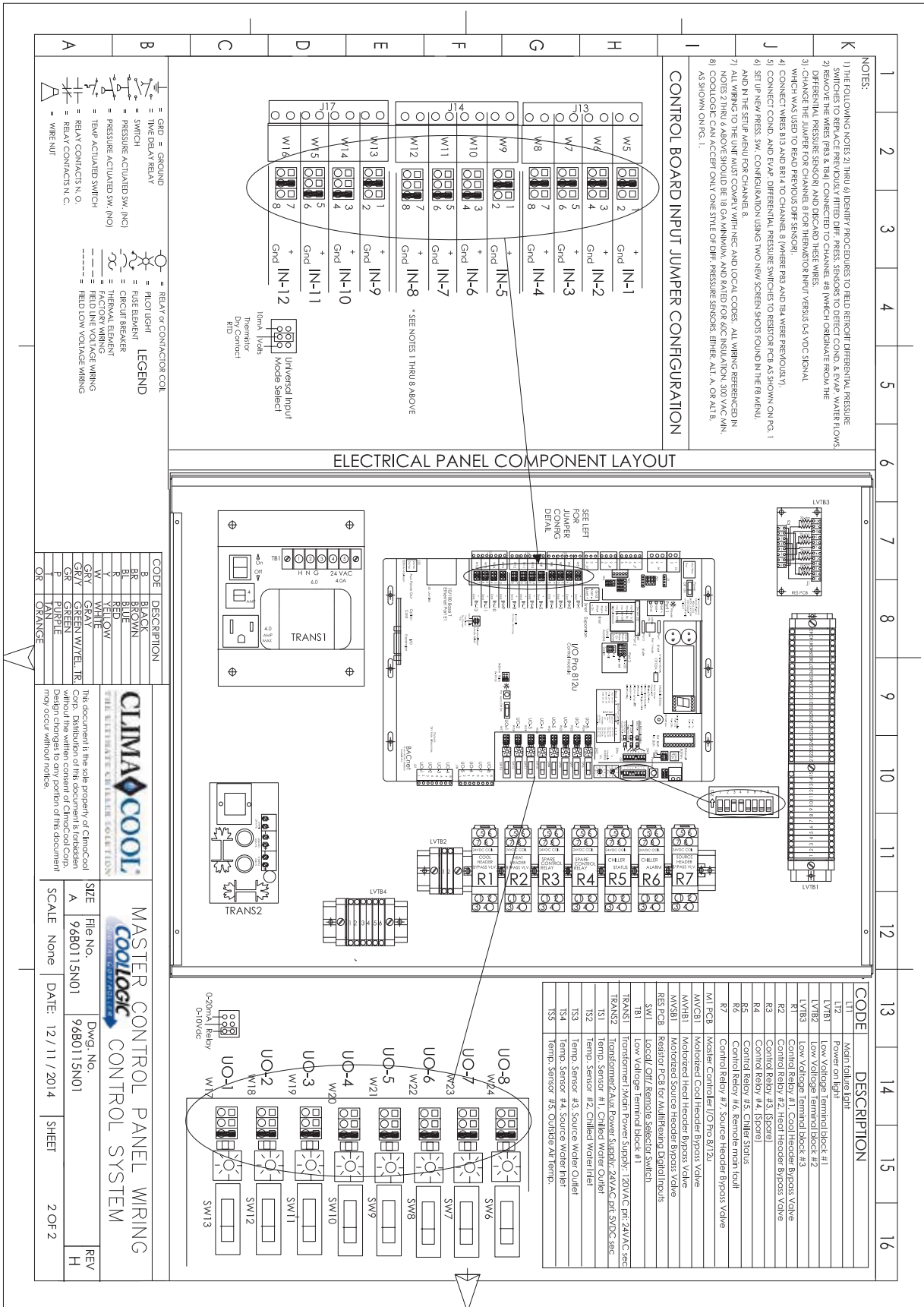

Wiring Diagrams - Expansion Board, SHC Heat Pump

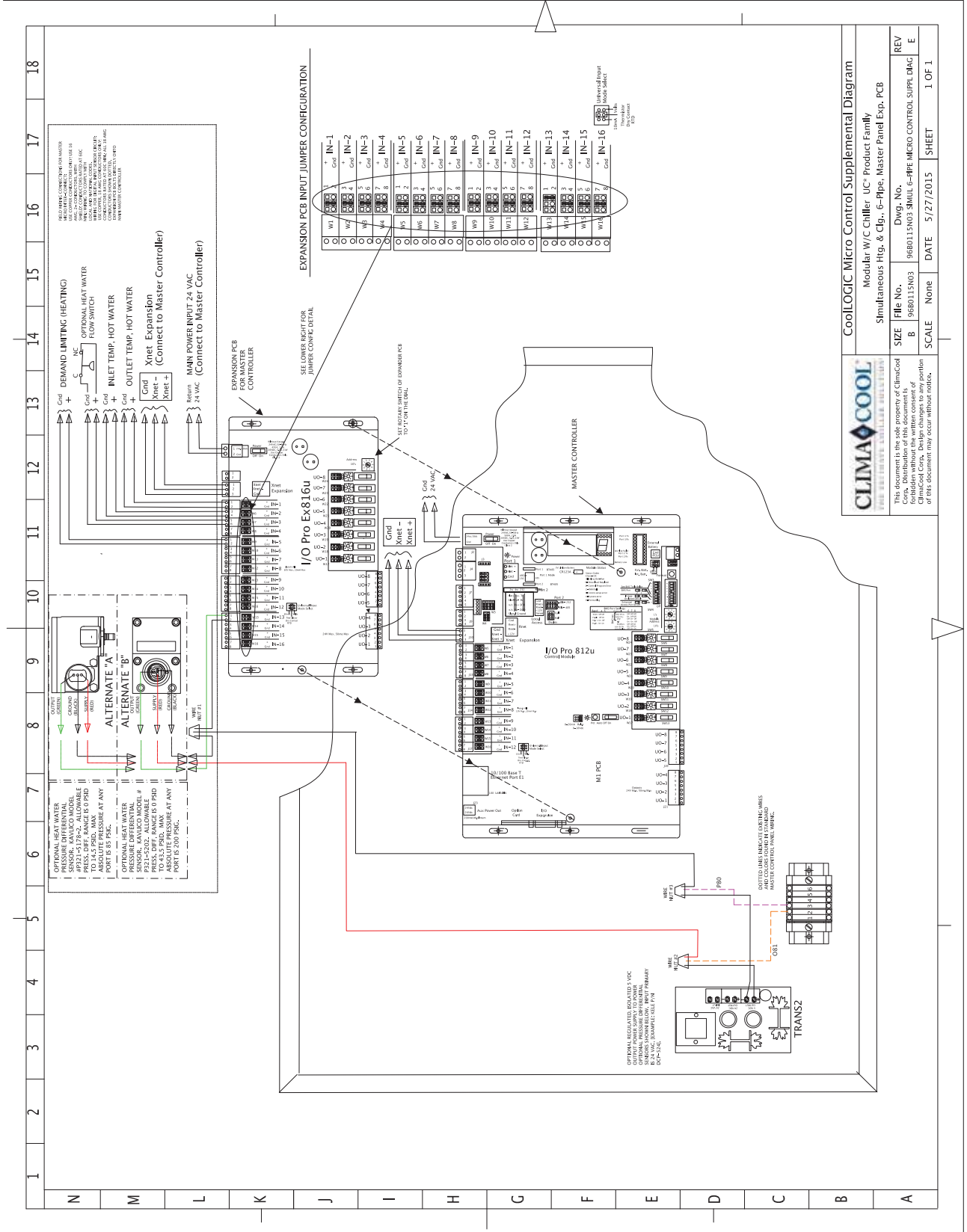

CLIMACOOL
 THE ULTIMATE CHILLER SOLUTION

CoolLogic Micro Control Supplemental Diagram
 Modular W/C Chiller UC- Product Family
 Simultaneous Htg. & Clg., 6-Pipe, Master Panel Exp. PCB

SIZE File No. 9880115ND3
 B 9880115ND3
 SCALE None
 DATE 5/27/2015
 SHEET 1 OF 1

REV E

Troubleshooting Guide



WARNING!

The troubleshooting guidelines recommended in this section could result in exposure to electrical safety hazards. Please refer to the safety warnings provided in this manual. Failure to follow all of the recommended safety warnings provided could result in death or serious injury. When possible, disconnect all electrical power including remote

disconnects before servicing. Follow proper lockout-tagout procedures. Only a qualified licensed electrician or persons trained to handle live electrical components should be allowed to work with energized electrical components.

Chiller Will Not Start		Compressor Cycles On High Pressure Control	
Possible Cause	Remedy	Possible Cause	Remedy
Power off	Check main disconnect switch	Water regulating valve incorrectly set or defective	Reset or replace
Main Line open	Check main fuses	Compressor discharge valve partially closed	Open valve to full open position
Incorrect wiring	Check the wiring diagram	Non-condensable gases in hydronic system	Purge non-condensable gases from bleed valve on condenser or at bleed valve of the building condenser water system
Loose terminals/connections	Tighten the terminal connections		
Control circuit open	Check interlocks with auxiliary equipment, pressure and temperature controls	Overcharge of refrigerant	Purge refrigerant from system while in operation until the first sign of bubbles are shown in the sight glass. Add back refrigerant just until bubbles clear.
Improper phasing of main power	Change any two of three phases of main power	Defective high pressure switch	Replace high pressure switch
Compressor Hums But Does Not Start		Causes and Prevention of Freeze-Up	
Possible Cause	Remedy	Possible Cause	Prevention
Low voltage	Check at main power entry and power entry at unit (Consult power company if low)	Improper charging	Charge per ClimaCool® data plate information, located on the chiller, following the Superheat and Subcooling procedure described on page 31.
Phase Loss	Check power wiring and fuses		
Compressor Runs But Does Not Cool		Improper chilled water circulation	Use an ample sized cleanable strainer in the chilled water circuit; make certain the strainer is clean to insure full flow and velocity of chilled water (strainer screen must be 60 mesh minimum). It may sometimes be necessary to treat the water to prevent formation of deposits.
Possible Cause	Remedy		
Improper phasing of main power	Switch any two of three phases of main power	Not draining for winter shutdown	When the system is shut down for the winter, remove the drain plugs and drain the cooler. Blow out remaining water with air.
Compressor Cuts Out On Low Pressure Safety Control		Faulty leaving chilled solution temperature sensor	Verify sensor calibration using a calibrated thermometer and replace if defective.
Possible Cause	Remedy	Wrong freeze-up protection temperature setpoint	Verify leaving chilled solution freeze protection temperature setpoint to be set at 8°F above solution freeze point.
Main chilled water valve closed or restricted	Open valve to full open position		
Module chilled water isolation valves, if provided, closed or restricted	Open valves to full open position		
Refrigerant shortage	Check for leaks - add refrigerant		
No load on water chiller	Check water pump operation		
Restriction in liquid line	Plugged liquid line drier - replace liquid line drier		
Expansion valve clogged or inoperative	Repair/Replace the expansion valve		
Low discharge pressure	Raise and control discharge pressure within design limits		
Low water flow through the cooler	Check water flow through the cooler		
Chilled water temperature too cold	Raise water temperature setpoint		
Fouled evaporator brazed plate heat exchanger	Clean-in-place heat exchanger as described on page 36		
Improper chilled water circulation	Use an ample sized cleanable strainer in the chilled water circuit; make certain the strainer is clean to insure full flow of chilled water (strainer screen must be 60 mesh minimum)		
Faulty suction pressure transducer	Verify transducer calibration using a calibrated manifold gauge and replace if defective.		
Wrong suction pressure cutout setpoint	Verify suction pressure cutout setpoint to be set equal to the corresponding leaving chilled solution freeze temperature equivalent pressure on a PT chart. (i.e. if the solution freeze point is 32°F the equivalent pressure setpoint will be 101 PSIG)		

⚠ WARNING/AVERTISSEMENT

<p>Disconnect power supply (ies) before servicing. Refer servicing to qualified service personnel. Electric shock hazard. May result in injury or death!</p>		<p>Debrancher avant d'entreprendre le dépannage de l'appareil. Consulter un réparateur qualifié pour le dépannage. Risque de choc électrique. Résultat de mai dans dommages ou la mort!</p>
⚠ CAUTION/ATTENTION		
<p>Unit to be serviced by qualified personnel only. Refrigerant system under pressure. Relieve pressure before using torch. Recover refrigerant and store or dispose of properly.</p>		<p>Conifer la maintenance à un technicien qualifié. Le système frigorifique sous pression. Décompresser avant d'exposer à la flamme. Récupérer le frigorigène et le stocker ou le détruire correctement.</p>



CLIMACOOL CORPORATION LIMITED EXPRESS WARRANTY/LIMITATION OF REMEDIES AND LIABILITY WITH EXTENDED COMPRESSOR WARRANTY

WARRANTY DISCLAIMER

It is expressly understood that unless a statement is specifically identified as a warranty, statements made by ClimaCool Corp., an Oklahoma corporation ("CC"), or its representatives, relating to CC's products, whether oral, written or contained in any quote, sales literature, catalog or any agreement, are not express warranties and do not form a part of the basis of the bargain, but are merely CC's opinion or commendation of CC's products. **EXCEPT AS SPECIFICALLY SET FORTH HEREIN, THERE IS NO EXPRESS WARRANTY AS TO ANY OF CC'S PRODUCTS. CC MAKES NO WARRANTY AGAINST LATENT DEFECTS. CC MAKES NO WARRANTY OF MERCHANTABILITY OF THE GOODS OR OF THE FITNESS OF THE GOODS FOR ANY PARTICULAR PURPOSE.**

GRANT OF LIMITED EXPRESS WARRANTY

CC warrants CC's products purchased and retained in the United States of America and Canada to be free from defects in material and workmanship under normal use and maintenance only as follows:

FOR MODULAR CHILLERS: (a) All modular chillers built or sold by CC for twelve (12) months from the date of unit start-up or eighteen (18) months from date of shipment (from CC's warehouse), whichever comes first; and (b) Any repair and replacement parts, which are not supplied under warranty, for ninety (90) days from date of shipment (from CC's warehouse) and (c) If such extended warranty is purchased, the compressors in all modular chillers built or sold by CC shall extend for sixty (60) months from the date of shipment (from CC's warehouse).

FOR ROOF TOP UNITS: (a) All roof top units built or sold by CC for twelve (12) months from the date of unit start-up or eighteen (18) months from date of shipment (from CC's warehouse), whichever comes first; (b) All compressors supplied by CC with CC's roof top units for sixty (60) months from date of shipment (from CC's warehouse); (c) All gas fired stainless steel heat exchangers supplied by CC with CC's roof top units for ten (10) years from date of shipment (from CC's warehouse); and (d) Any repair and replacement parts, which are not supplied under warranty, for ninety (90) days from date of shipment (from CC's warehouse).

All parts must be returned to CC's warehouse in Oklahoma City, Oklahoma, freight prepaid, no later than sixty (60) days after the date of the failure of the part. If CC determines the part to be defective and within CC's Limited Express Warranty, CC shall, when such part has been either replaced or repaired, return such to a CC recognized dealer, contractor or service organization, F.O.B. CC's warehouse, Oklahoma City, Oklahoma, freight prepaid. The warranty on any part repaired or replaced under warranty expires at the end of the original warranty period.

This warranty does not cover and does not apply to: (1) Fuses, refrigerant, fluids, oil; (2) Products relocated after initial installation; (3) Any portion or component of the system that is not supplied by CC, regardless of the cause of the failure of such portion or component; (4) Products on which the units identification tags or labels have been removed or defaced; (5) Products on which payment to CC is or has been in default; (6) Products which have defects or damage which result from improper installation, wiring, electrical imbalance characteristics or maintenance (including, without limitation, defects or damages caused by voltage surges, inadequate voltage conditions, phase imbalance, any form of electrical disturbances, inadequate or improper electrical circuit installation or protection, failure to perform common maintenance, etc.); or are caused by accident, misuse or abuse, fire, flood, alteration or misapplication of the product; (7) Products which have defects or damage which result from a contaminated air or liquid supply, operation at abnormal temperatures; or unauthorized opening of refrigerant circuit; (8) Products subjected to corrosion or abrasion or chemicals; (9) Mold, fungus or bacteria damage; (10) Products manufactured or supplied by others; (11) Products which have been subjected to misuse, negligence or accidents; (12) Products which have been operated in a manner contrary to CC's printed instructions; (13) Products which have defects, damage or insufficient performance as a result of insufficient or incorrect system design or the improper application of CC's products; (14) Products which have defects or damages due to freezing of the water supply, an inadequate or interrupted water supply, corrosives or abrasives in the water supply, or improper or inadequate filtration or treatment of the water or air supply; (15) Products which are defects caused by overfiring, use of incorrect fuel, or improper burn or control adjustments; or (16) Products which have incomplete or inadequate combustion.

CC is not responsible for: (1) The costs of any fluids, refrigerant or other system components, or the associated labor to repair or replace the same, which is incurred as a result of a defective part covered by CC's Limited Express Warranty; (2) The costs of labor, refrigerant, materials or service incurred in removal of the defective part, or in obtaining and replacing the new or repaired part; or, (3) Transportation costs of the defective part from the installation site to CC or the return of any part not covered by CC's Limited Express Warranty.

Limitation: This Limited Express Warranty is given in lieu of all other warranties. If, notwithstanding the disclaimers contained herein, it is determined that other warranties exist, any such warranty, including without limitation, any express warranties or any implied warranties of fitness for any particular purpose and merchantability, shall be limited to the duration of the Limited Express Warranty.

LIMITATION OF REMEDIES

In the event of a breach of this Limited Express Warranty, CC will only be obligated at CC's option to repair the failed part or module or to furnish a new or rebuilt part or module in exchange for the part or module which has failed. If, after written notice to CC's Head Office in Oklahoma City, Oklahoma, of each defect, malfunction or other failure and a reasonable number of attempts by CC to correct the defect, malfunction or other failure and the remedy fails of its essential purpose, CC shall refund the purchase price paid to CC in exchange for the return of the sold good(s). Said refund shall be the maximum liability of CC. **THIS REMEDY IS THE SOLE AND EXCLUSIVE REMEDY AGAINST CC FOR BREACH OF CONTRACT, FOR THE BREACH OF ANY WARRANTY OR FOR CC'S OWN NEGLIGENCE OR IN STRICT LIABILITY.**

LIMITATION OF LIABILITY

CC shall have no liability for any damages, if CC's performance is delayed for any reason or is prevented to any extent by any event such as, but not limited to any, war, civil unrest, government restrictions or restraints, strikes, or work stoppages, fire, flood, accident, allocation, shortages of transportation, fuel, material or labor, acts of God or any other reason beyond the sole control of CC. **CC EXPRESSLY DISCLAIMS AND EXCLUDES ANY LIABILITY FOR CONSEQUENTIAL OR INCIDENTAL DAMAGE IN CONTRACT, FOR BREACH OF ANY EXPRESS OR IMPLIED WARRANTY, OR IN TORT, WHETHER FOR CC'S OWN NEGLIGENCE OR AS STRICT LIABILITY.**

OBTAINING WARRANTY PERFORMANCE

Normally, the contractor or service organization who installed the products will provide warranty performance for the owner. Should the installer be unavailable, contact any CC recognized contractor or service organization. If assistance is required in obtaining warranty performance, write:

ClimaCool Corp. • P.O. Box 2055 • Oklahoma City, Oklahoma 73101 • (405) 815-3000 • e-mail: Claims@climacoolcorp.com

NOTE: Some states or Canadian provinces do not allow limitations on how long an implied warranty lasts, or the limitation or exclusion of consequential or incidental damages, so the foregoing exclusion and limitations may not apply to you. This warranty gives you specific legal rights, and you may also have other rights which vary from state to state and from Canadian province to Canadian province.

Please refer to the CC Installation, Operation and Maintenance Manual for operating and maintenance instructions.

forms\ccool\standard forms\word files\CCool warranty compressor certificate 07-17-14



CLIMACOOOL
THE ULTIMATE CHILLER SOLUTION®

15 S. Virginia
Oklahoma City, OK 73106
Phone: 405.815.3000
Fax: 405.815.3052
www.climacoolcorp.com



ClimaCool works continually to improve its products. As a result, the design and specifications of each product at the time for order may be changed without notice and may not be as described herein. Please contact ClimaCool's Customer Service Department at 405-815-3000 for specific information on the current design and specifications. Statements and other information contained herein are not express warranties and do not form the basis of any bargain between the parties, but are merely ClimaCool's opinion or commendation of its products.

'USGBC®' and related logo is a trademark owned by the U.S. Green Building Council® and is used with permission.