

MODEL L-AV-1-F-OB

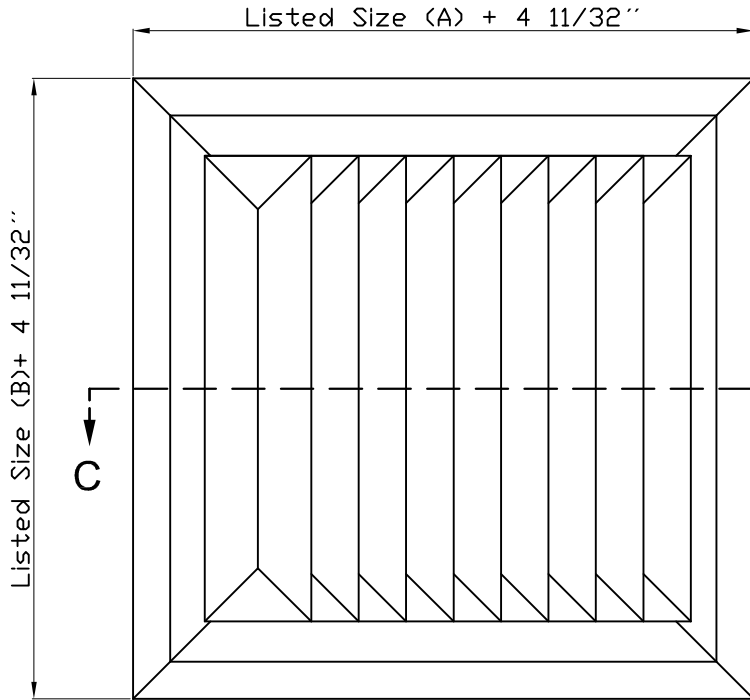

STYLE 07 (Square)

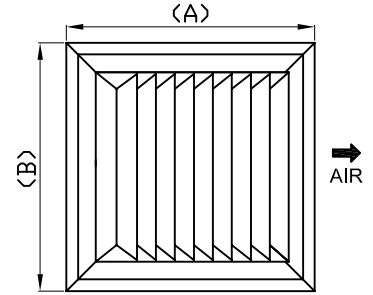

STYLE 07 (Rectangular)

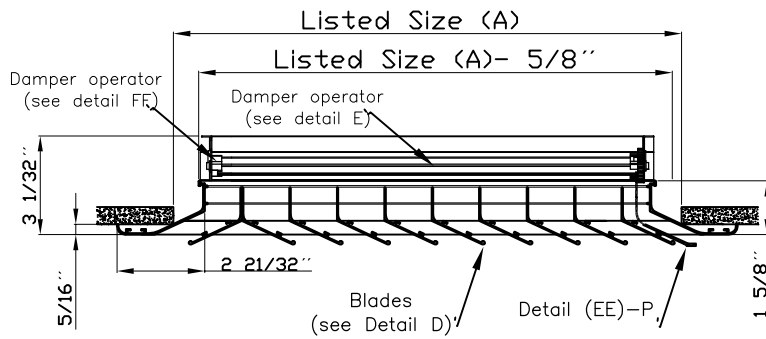
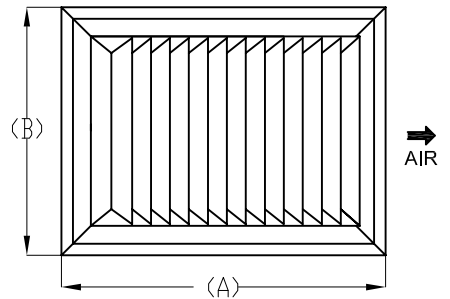

SECTION C - C

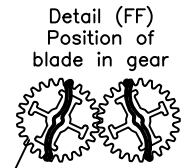
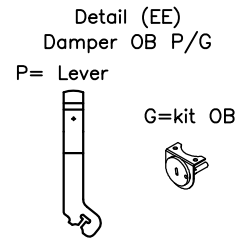
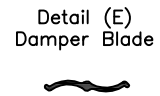
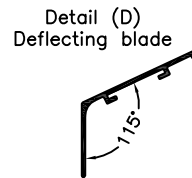

Material : polypropylene

Finish
White (Standard)
Other colors (Optional)

Note: Available in sizes (A)x(B): 6"x6" to 30"x30"

Dimensions are in inches

MODEL L-AV-1-F-OB

Extruded Aluminum

Job Name: _____

Architect: _____

Location: _____

Engineer: _____

Contractor: _____

MODEL L-AV-1-S-OB

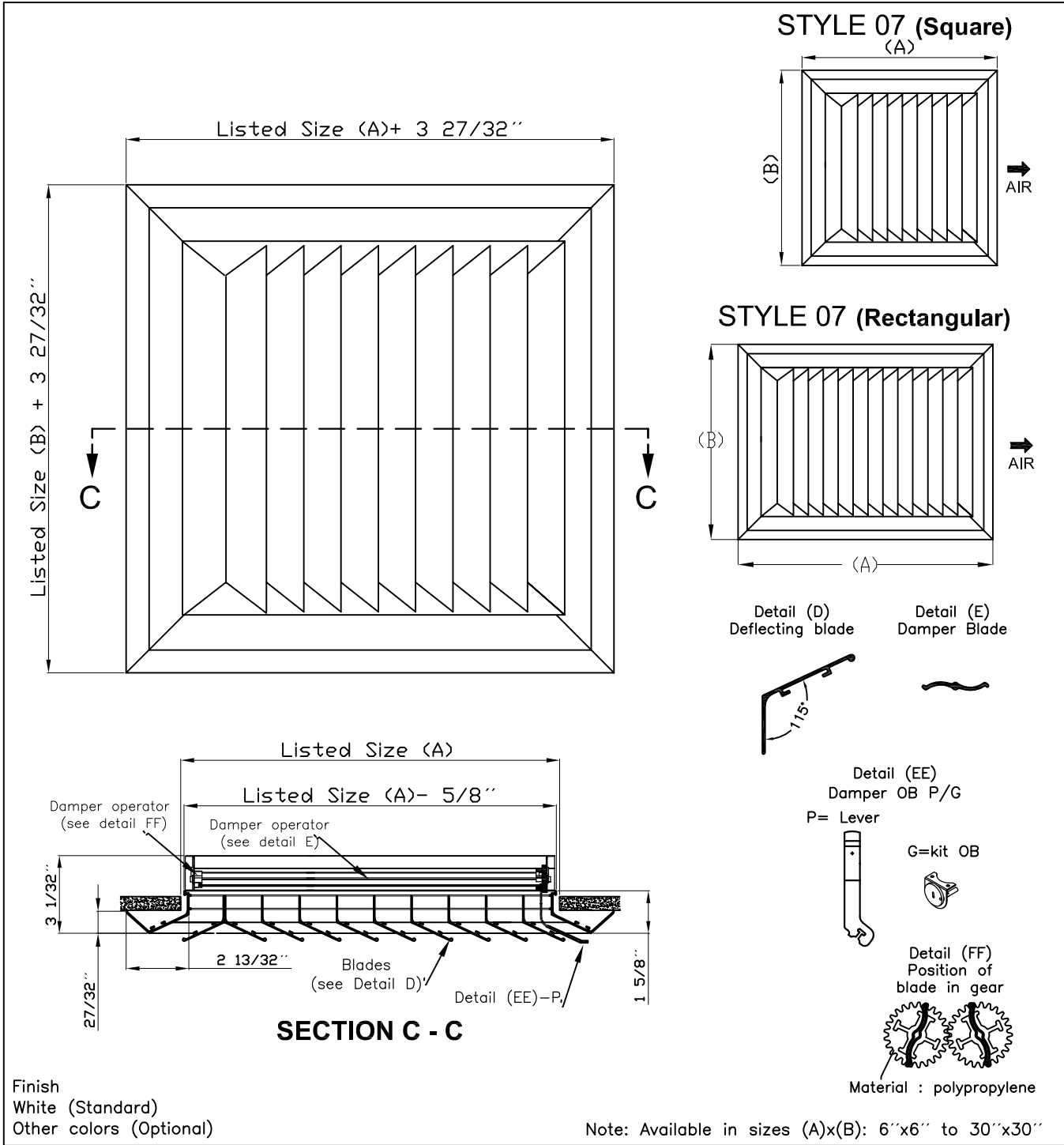

MODEL L-AV-1-S-OB

Extruded Aluminum

Job Name: _____
Location: _____

Architect: _____
Engineer: _____
Contractor: _____



LAMINAIRE[®]

Grilles, Diffusers and A/C Accessories

Submittal

MODEL L-AV-2-180°-F-OB

STYLE 06 (Square)

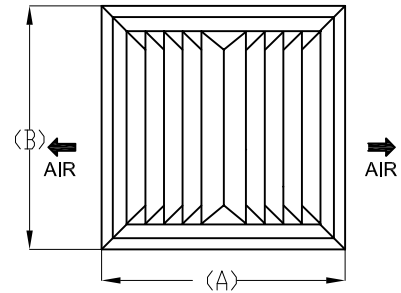

STYLE 06 (Rectangular)

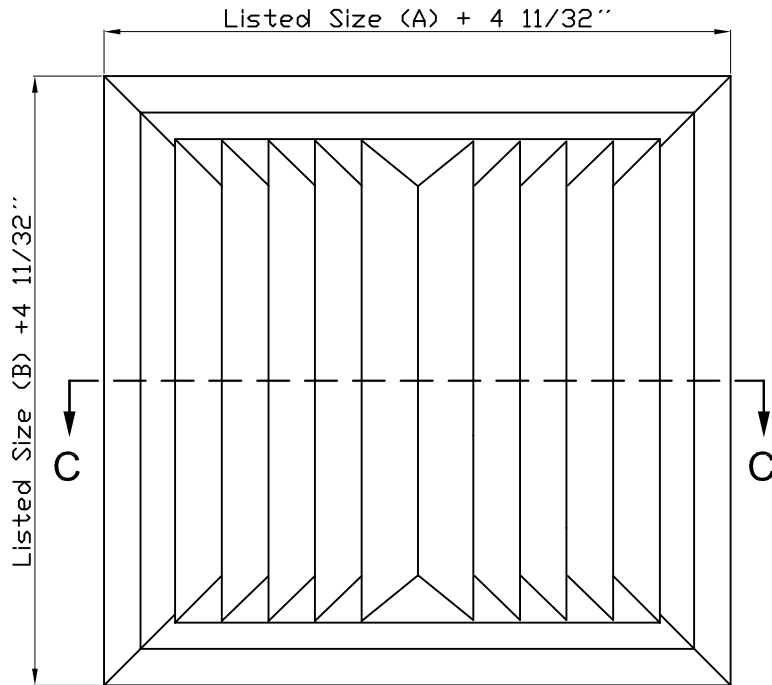
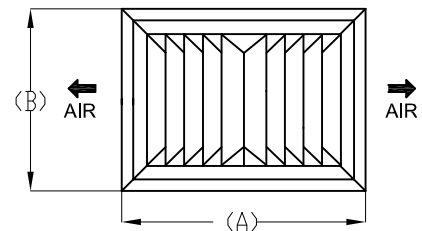

Detail (D)
Deflecting blade

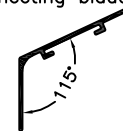

Detail (E)
Damper Blade



Detail (EE)
Damper OB P/G

P= Lever

G=kit OB

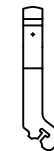

Detail (FF)
Position of
blade in gear

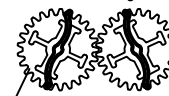

Material : polypropylene

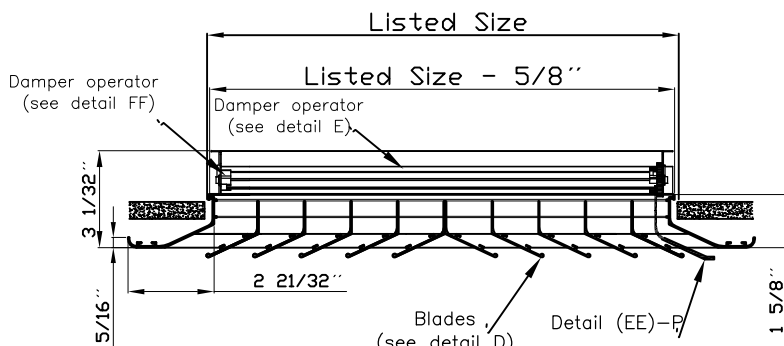

SECTION C - C

Finish
White (Standard)
Other colors (Optional)

Note: Available in sizes (A)x(B): 6"x6" to 30"x30"

Dimensions are in inches

MODEL L-AV-2-180°-F-OB

Extruded Aluminum

Job Name: _____

Architect: _____

Location: _____

Engineer: _____

Contractor: _____

MODEL L-AV-2-180°-S-OB

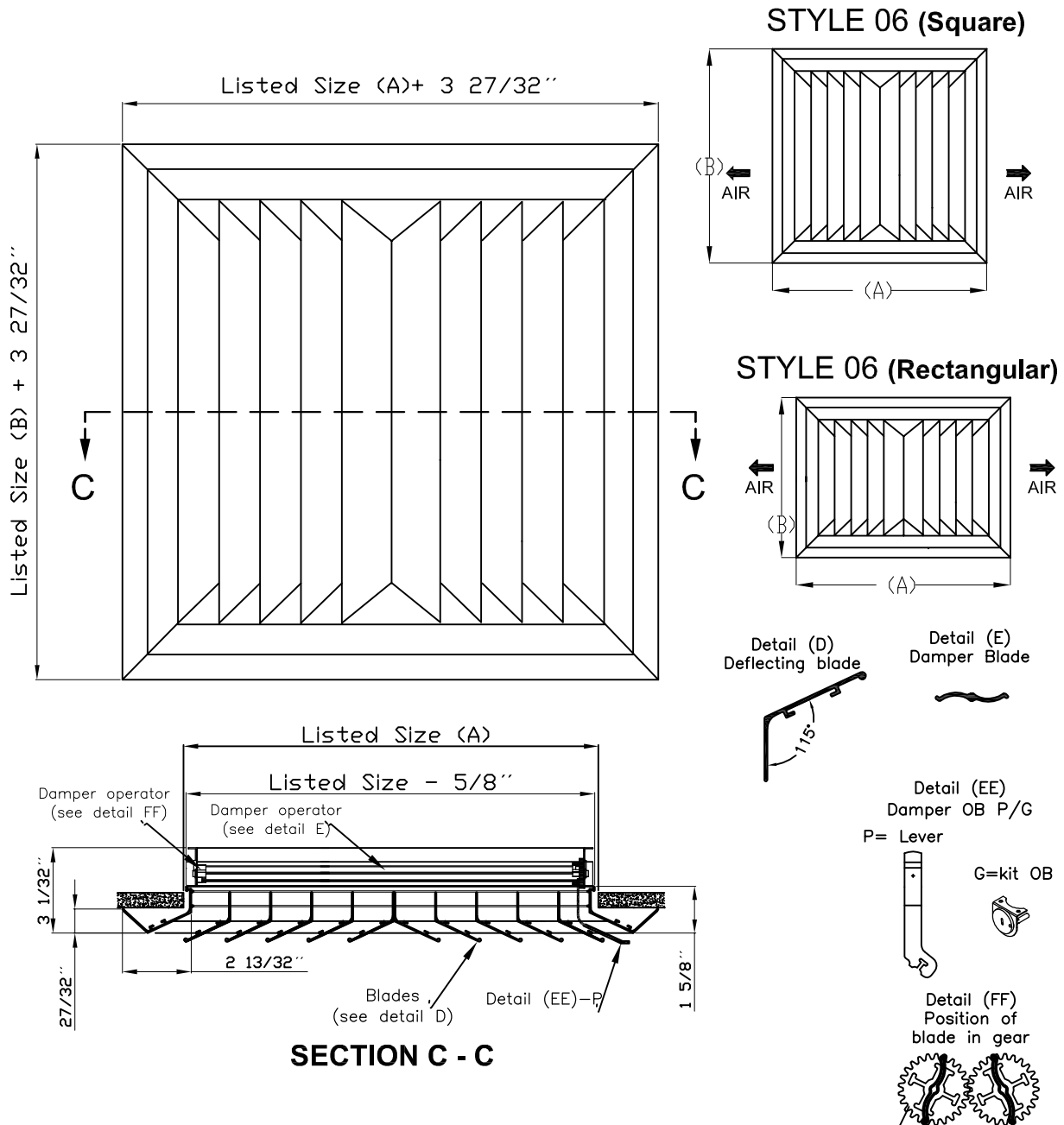

Finish
 White (Standard)
 Other colors (Optional)

Note: Available in sizes (A)x(B): 6"x6" to 30"x30"
 Dimensions are in inches

MODEL L-AV-2-180°-S-OB

Extruded Aluminum

Job Name: _____

Architect: _____

Location: _____

Engineer: _____

Contractor: _____



LAMINAIRE[®]

Grilles, Diffusers and A/C Accessories

Submittal

MODEL L-AV-2-90°-F-OB

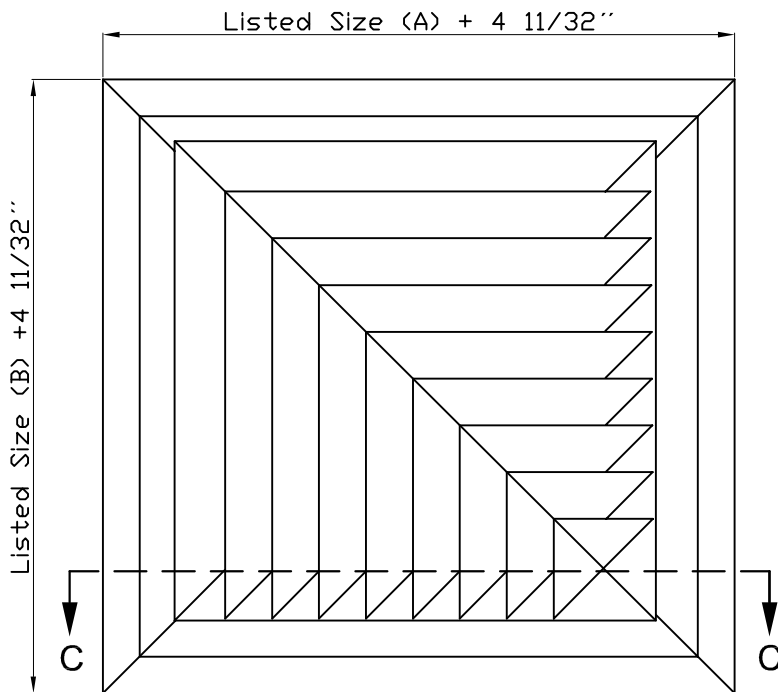

STYLE 03 (Square)

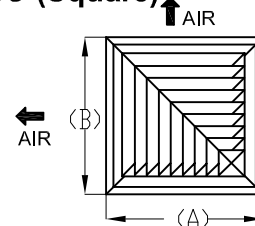

STYLE 04 (RIGHT)

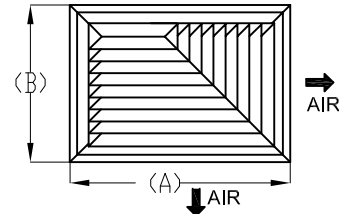

STYLE 05 (LEFT)

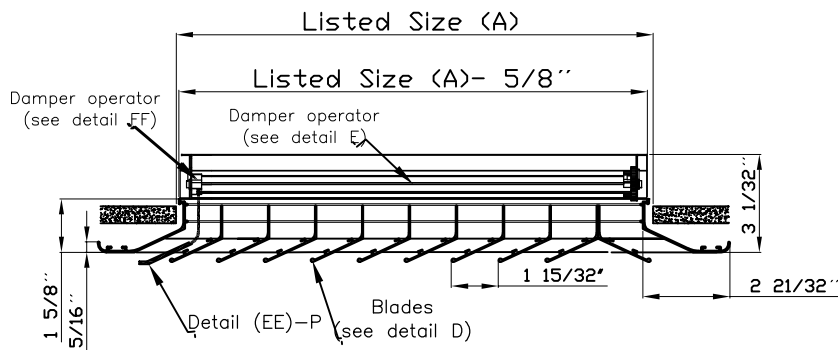
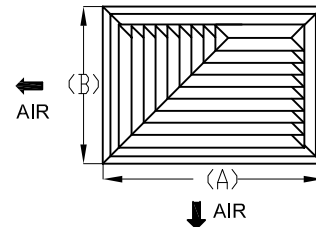

SECTION C - C

Detail (D) Deflecting blade
Detail (E) Damper Blade

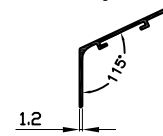

Detail (EE) Damper OB P/G

P= Lever

G=kit OB

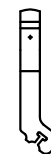

Detail (FF) Position of blade in gear

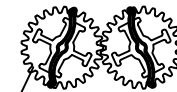

Material : polypropylene

Finish
White (Standard)
Other colors (Optional)

Note: Available in sizes (A)x(B): 6"x6" to 30"x30", multiples 3 on 3.

Dimensions are in inches

MODEL L-AV-2-90°-F-OB

Extruded Aluminum

Job Name: _____

Architect: _____

Location: _____

Engineer: _____

Contractor: _____

MODEL L-AV-2-90°-F-OB

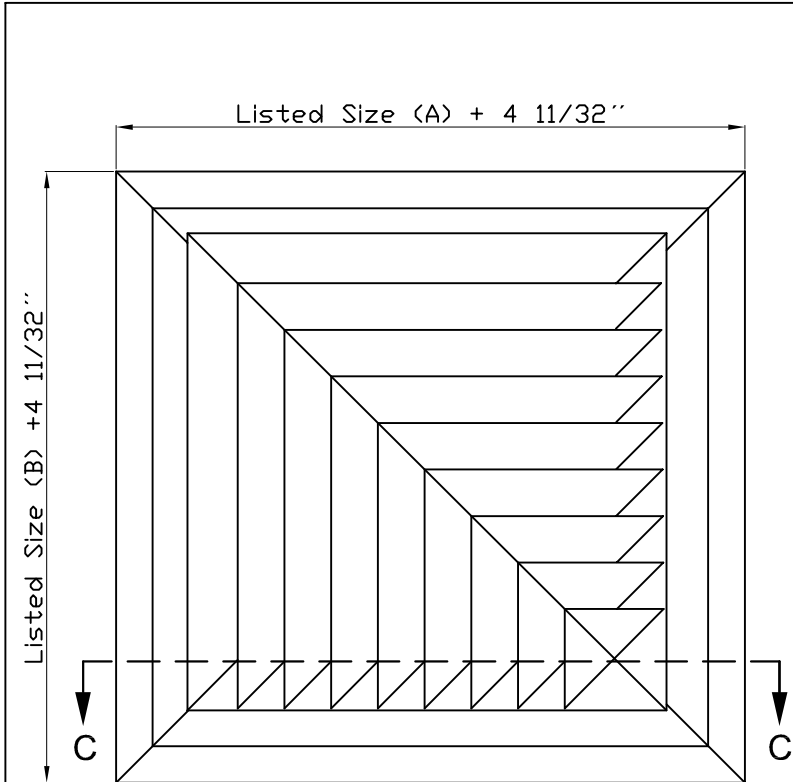

STYLE 03 (Square)

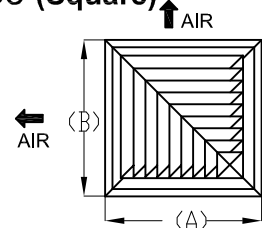

STYLE 04 (RIGHT)

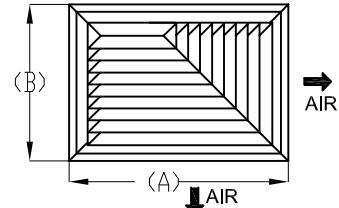

STYLE 05 (LEFT)

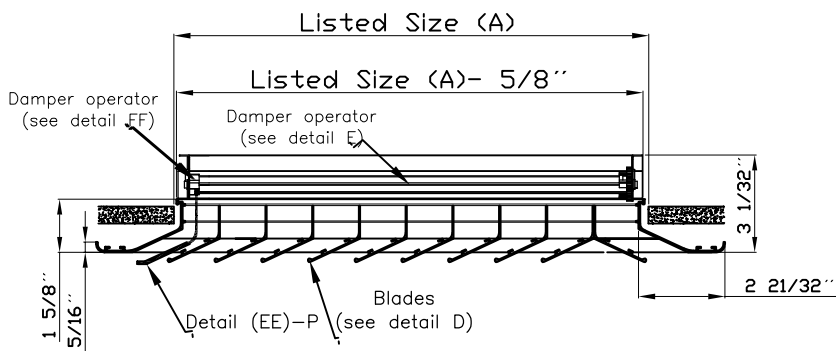
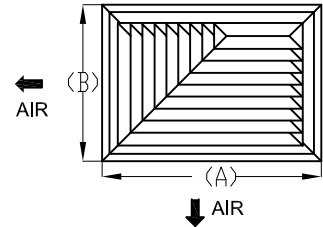

SECTION C - C

Detail (D) Deflecting blade

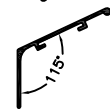

Detail (E) Damper Blade



Detail (EE) Damper OB P/G

P= Lever

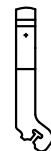

G=kit OB



Detail (FF) Position of blade in gear

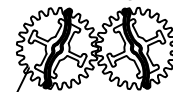

Material : polypropylene

Finish
White (Standard)
Other colors (Optional)

Note: Available in sizes (A)x(B): 6"x6" to 30"x30"

Dimensions are in inches

MODEL L-AV-2-90°-F-OB

Extruded Aluminum

Job Name: _____

Architect: _____

Location: _____

Engineer: _____

Contractor: _____



LAMINAIRE[®]

Grilles, Diffusers and A/C Accessories

Submittal

MODEL L-AV-2-90°-S-OB

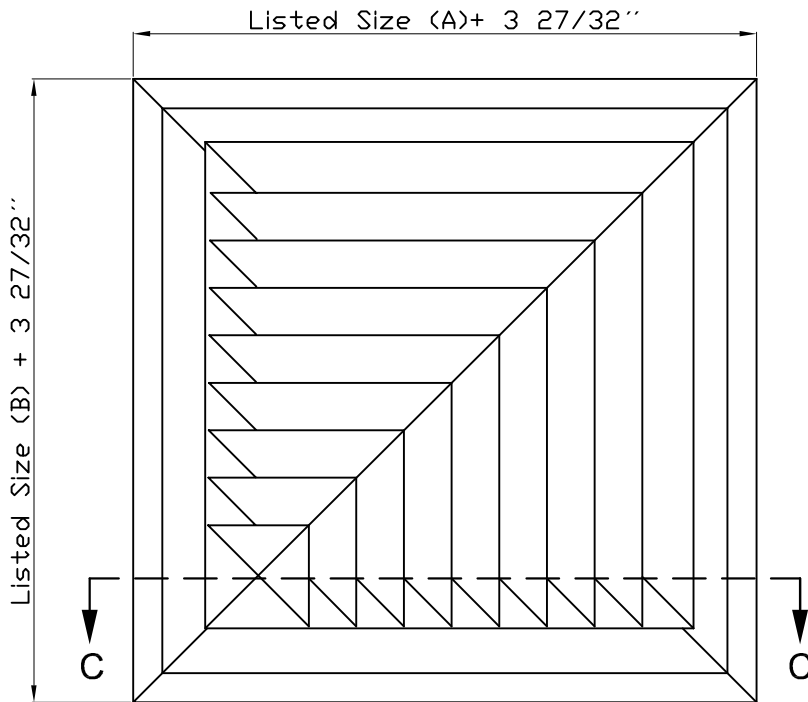

STYLE 03 (Square)

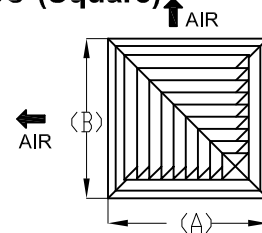

STYLE 04 (RIGHT)

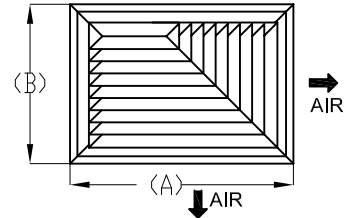

STYLE 05 (LEFT)

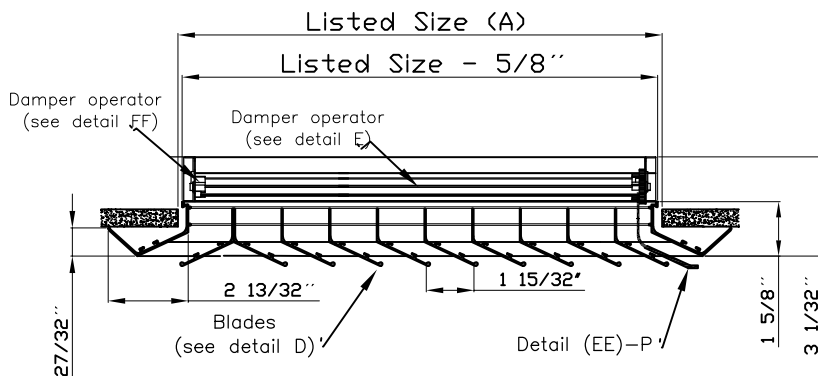
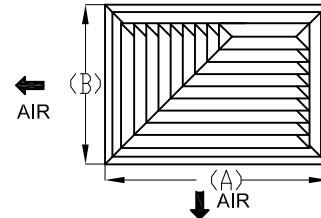

SECTION C - C

Detail (D) Deflecting blade Detail (E) Damper Blade

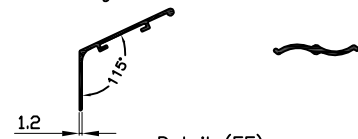

Detail (EE) Damper OB P/G

P= Lever G=kit OB

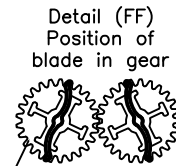
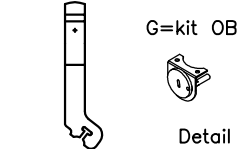

Material : polypropylene

Note: Available in sizes (A)x(B): 6"x6" to 30"x30", multiples 3 on 3.

Finish
White (Standard)
Other colors (Optional)

Dimensions are in inches

Extruded Aluminum

MODEL L-AV-2-90°-S-OB

Job Name: _____

Architect: _____

Location: _____

Engineer: _____

Contractor: _____



LAMINAIRE[®]

Grilles, Diffusers and A/C Accessories

Submittal

MODEL L-AV-2-90°-S-OB

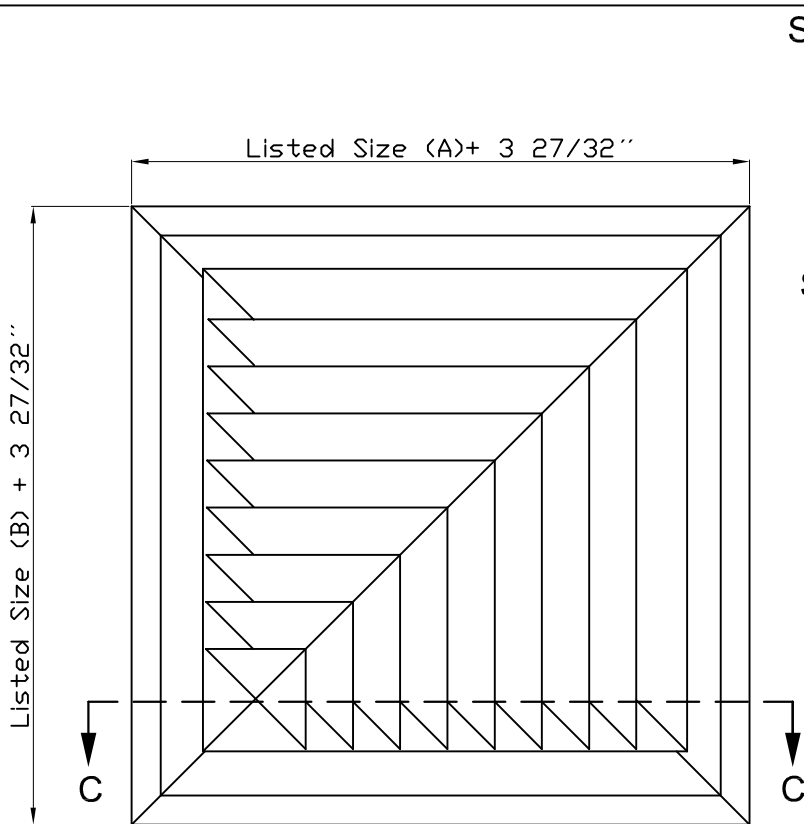

STYLE 03 (Square)

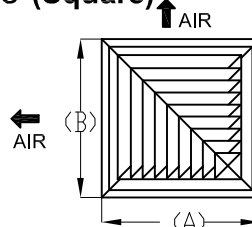

STYLE 04 (RIGHT)

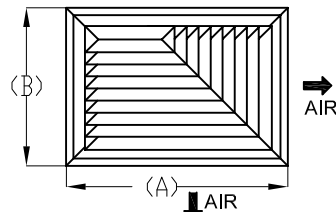

STYLE 05 (LEFT)

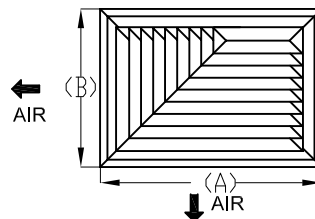

Detail (D)
Deflecting blade

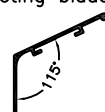

Detail (E)
Damper Blade



Detail (EE)
Damper OB P/G

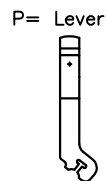

G=kit OB



Detail (FF)
Position of
blade in gear

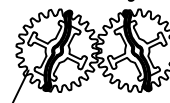

Material : polypropylene

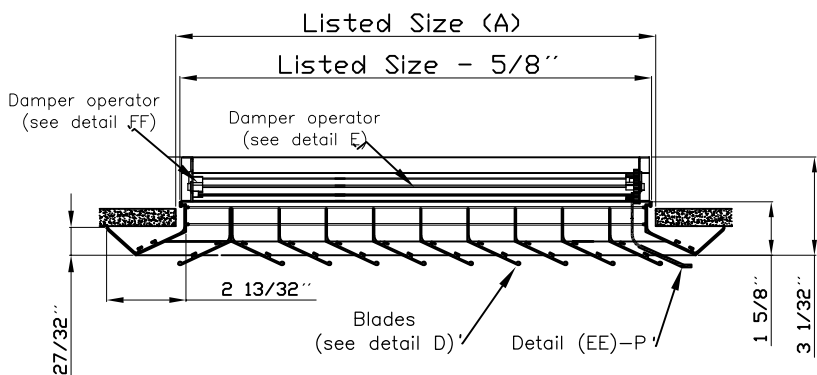

SECTION C - C

Finish
White (Standard)
Other colors (Optional)

Note: Available in sizes (A)x(B): 6"x6" to 30"x30"

Dimensions are in inches

Extruded Aluminum

MODEL L-AV-2-90°-S-OB

Job Name: _____

Architect: _____

Location: _____

Engineer: _____

Contractor: _____

MODEL L-AV-3-F-OB

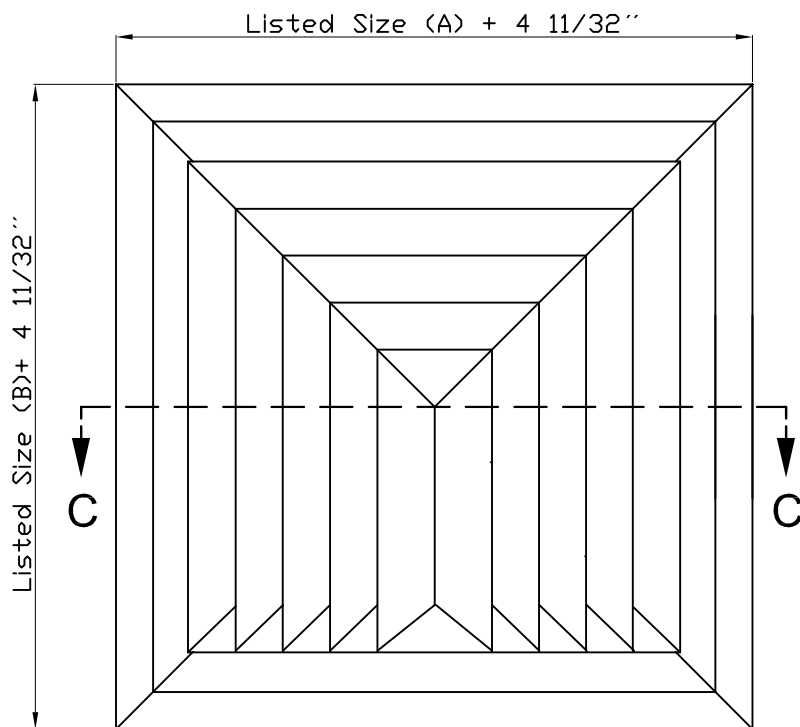

STYLE 02 (Square)

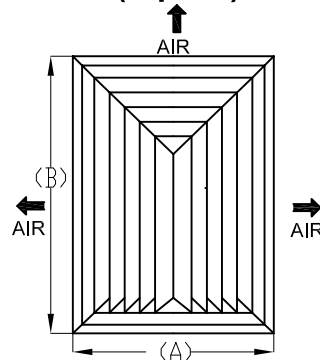

STYLE 02 (Rectangular)

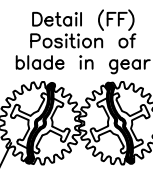
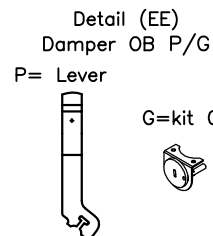
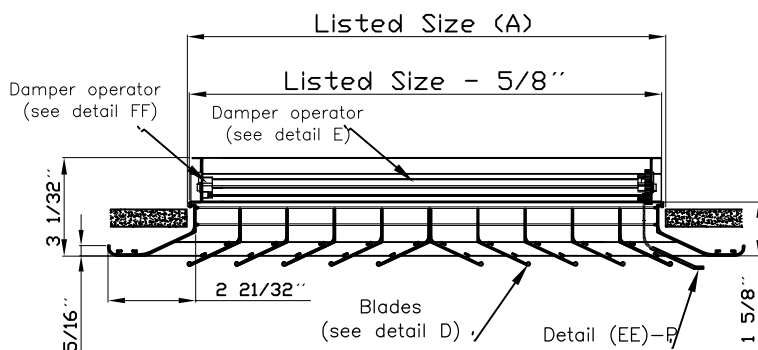
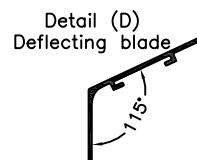
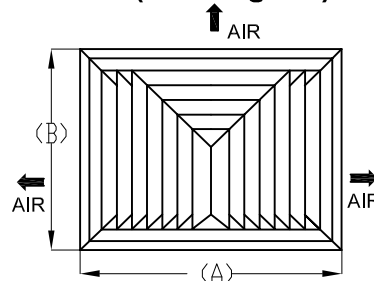

Material : polypropylene

Finish
White (Standard)
Other colors (Optional)

Note: Available in sizes (A)x(B): 6"x6" to 30"x30"
Dimensions are in inches

MODEL L-AV-3-F-OB

Extruded Aluminum

Job Name: _____

Architect: _____

Location: _____

Engineer: _____

Contractor: _____

MODEL L-AV-3-S-OB

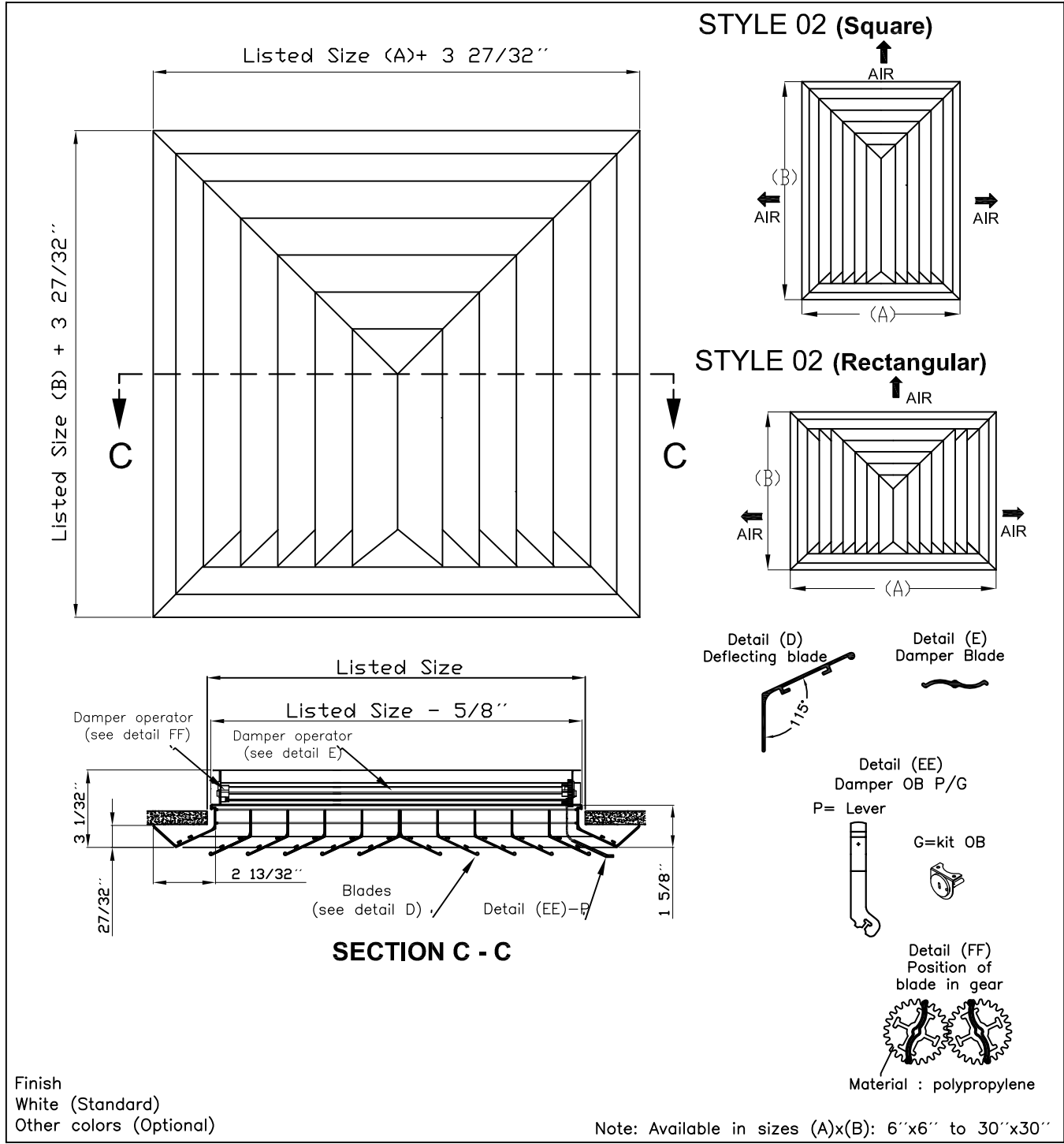

MODEL L-AV-3-S-OB

Extruded Aluminum

Job Name: _____
Location: _____

Architect: _____
Engineer: _____
Contractor: _____



LAMINAIRE[®]

Grilles, Diffusers and A/C Accessories

Submittal

MODEL L-AV-4-F-OB

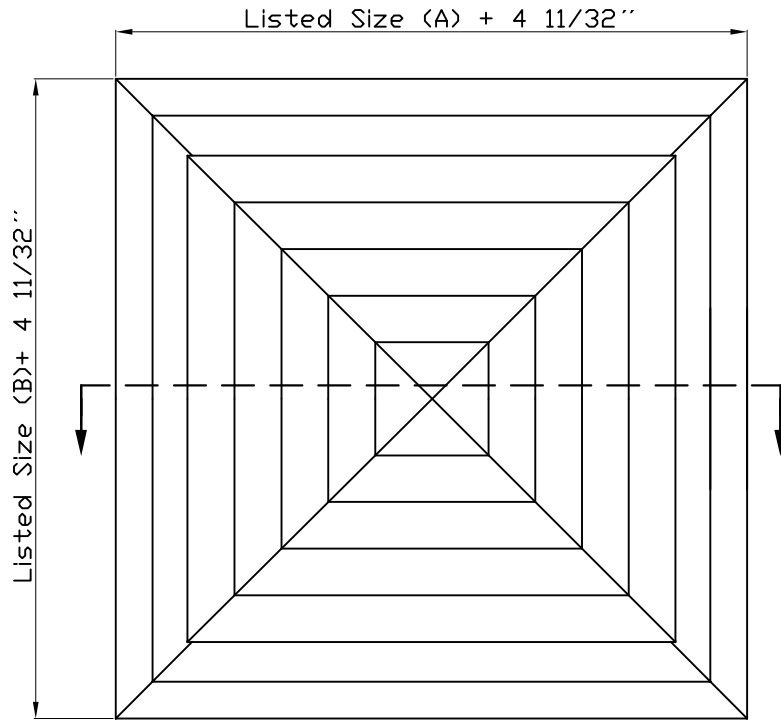

STYLE 01 (Square)

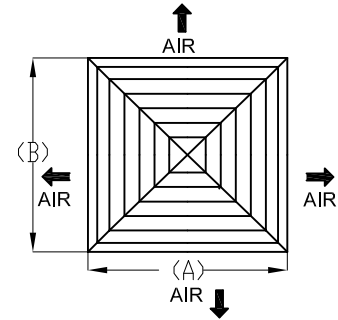

STYLE 01 (Rectangular)

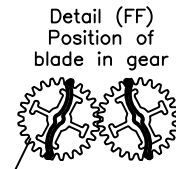
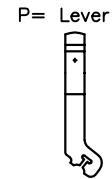
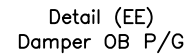
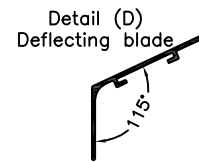
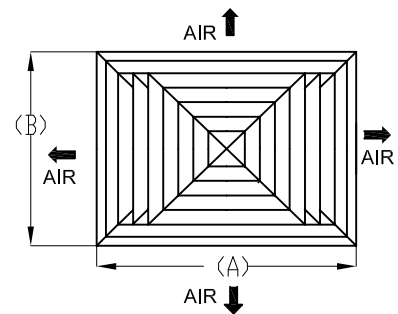

Material : polypropylene

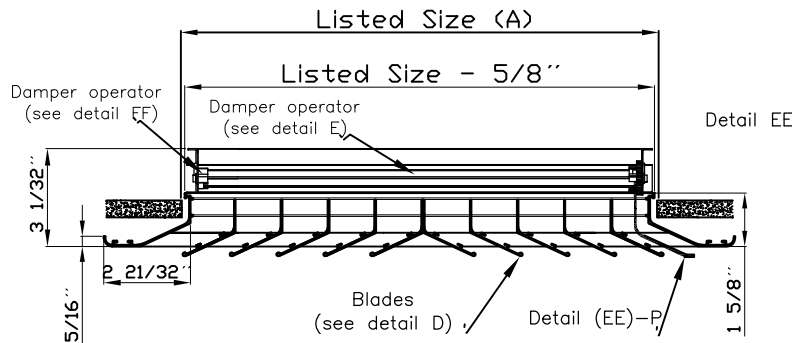

SECTION C - C

Finish
 White (Standard)
 Other colors (Optional)

Note: Available in sizes (A)x(B): 6"x6" to 30"x30"

Dimensions are in inches

MODEL L-AV-4-F-OB

Extruded Aluminum

Job Name: _____
 Location: _____

Architect: _____
 Engineer: _____
 Contractor: _____



MODEL L-AV-4-S-OB

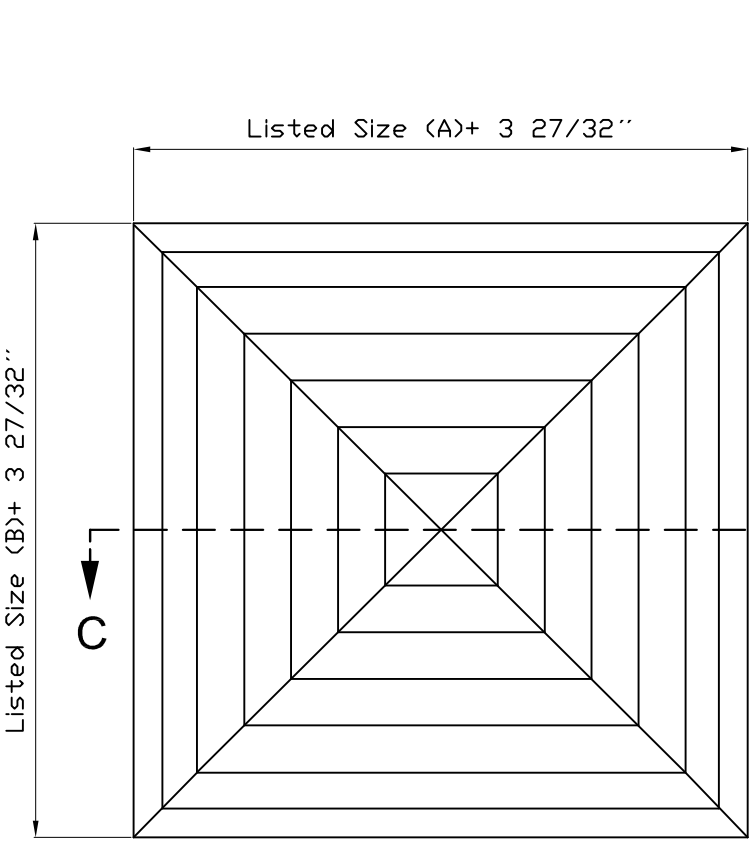

STYLE 01 (Square)

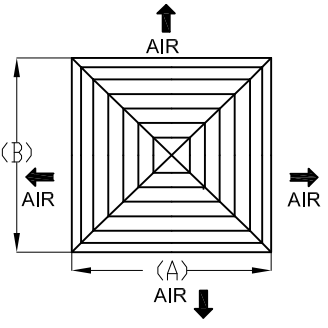

STYLE 01 (Rectangular)

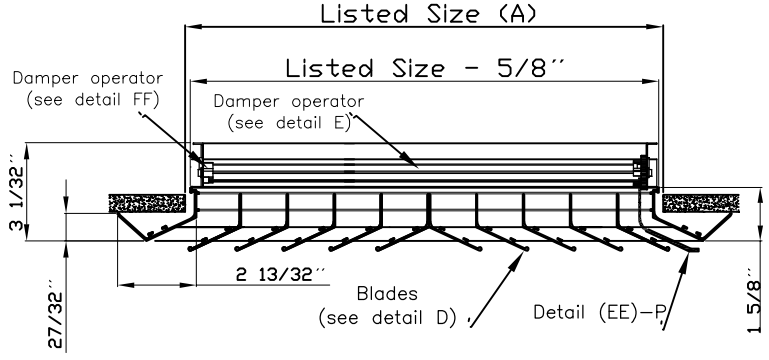
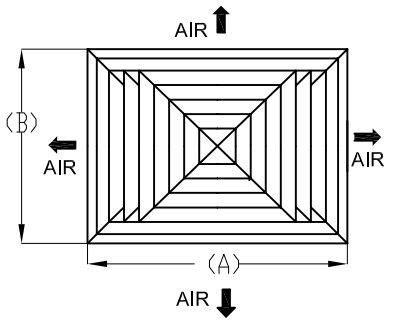

SECTION C - C

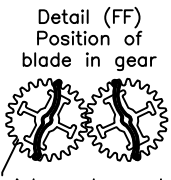
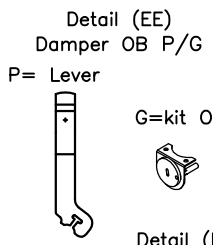
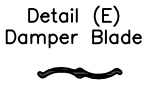
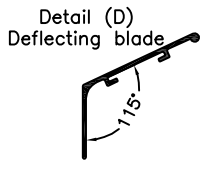

Material : polypropylene

Finish
White (Standard)
Other colors (Optional)

Note: Available in sizes (A)x(B): 6"x6" to 30"x30"
Dimensions are in inches

MODEL L-AV-4-S-OB

Extruded Aluminum

Job Name: _____
Location: _____

Architect: _____
Engineer: _____
Contractor: _____