

Configured Packaged Rooftop Solutions

2 Series & 4 Series 6-40 Tons

Installation, Operation & Maintenance Manual



CLIMA  COOL[®]
THE ULTIMATE ROOFTOP SOLUTION[®]

Table of Contents

General Information	1
Code String	4
Pre-Installation	10
Dimensional Drawings.....	11
Unit Installation	19
Service Clearance	19
Roof Curbs	20
Rigging and Handling	22
Unit and Component Weights	23
Condensate Drain Piping	24
Air Cooled	25
Water Source	25
Water Treatment	26
Glycol Performance Adjustment Factors Charts	27
Electrical	28
Pre-Startup	29
Startup	30
Superheat & Subcooling Flow Chart	32
Refrigerant Temperature Pressure Chart	33
Temperature Sensor Chart	34
Startup and Warranty Registration Form	35
Refrigeration Circuit Diagram	37
Refrigeration System.....	40
Refrigeration System Re-Processing	42
Factory Installed Options	43
Maintenance.....	47
Warranty	50

General Information

ClimaCool's solutions to configured packaged rooftop units offer Air Cooled cooling and heat pump, Water Cooled cooling and heat pump, Geothermal heat pump and Chiller water air handling applications. This manual provides general information about the 2 Series and 4 Series units available in 6 – 40 tons.

Unit Nameplate

The unit nameplate is located on both the outside and the inside of the main control panel door. It includes the unit model number, serial number, electrical data and refrigerant charge.

Safety Information

Throughout this manual warning, danger, caution and attention notices appear. Read these items carefully before attempting any installation, service or troubleshooting of the equipment. All labels on unit access panels must be observed.

DANGER: Immediate hazardous situation which, if not avoided, **will** result in death or serious injury.

WARNING: Potentially hazardous situation which, if not avoided, **could** result in death or serious injury.

CAUTION: Potentially hazardous situation or an unsafe practice which, if not avoided, **could** result in minor or moderate injury or product or property damage.

ATTENTION: Notification of installed, operation or maintenance information which is important, but **not** hazard related.

⚠ CAUTION/ATTENTION	
Gas-fired furnaces are not designed for use in hazardous atmospheres containing flammable vapors or combustible dust, in atmospheres containing chlorinated or halogenated hydrocarbons, or in applications with airborne substances containing silicone.	Fours à gaz sont pas conçus pour être utilisés dans des atmosphères dangereuses contenant des vapeurs inflammables ou poussières combustibles, dans des atmosphères contenant des hydrocarbures chlorés ou halogénés, ou dans des applications avec des substances dans l'air contenant de la silicone.

ATTENTION
This furnace is not listed or suitable for drying or process applications. Use in such applications voids any warranty and manufacturer disclaims any responsibility for the furnace and/ or application.

CAUTION/ATTENTION	
The presence of chlorine vapors in the combustion air supplied to gas-fired heaters presents a substantial corrosion hazard.	La présence de vapeurs de chlore dans l'air de combustion fourni à ce four a un haut risque de corrosion.

CAUTION/ATTENTION	
Flue gases must be directed away from combustion air inlets to avoid recirculation into combustion air supply.	Les gaz de combustion doivent être dirigés loin de prises d'air de combustion pour éviter la recirculation dans l'alimentation en air de combustion.



ATTENTION
When pressure testing is at 1/2 psi or less, close the manual shut off valve on the furnace before testing.
When pressure testing gas supply line at 1/2 psi or higher, close manual gas valve and disconnect heater from supply line to be tested. Cap or plug the supply line.

ATTENTION
Internal water strainer requires cleaning.

⚠ CAUTION/ATTENTION	
All field piping must be pressure/leak tested prior to operation. NEVER use an open flame to check for leaks. Use soap solution or other leak detecting solution.	Toutes les conduites de gaz reliés à l'appareil doivent être inspectés pour des fuites sous pression avant d'utiliser. NE JAMAIS utiliser une flamme nue pour vérifier les fuites. Utilisez une solution de savon ou autre solution de détection des fuites.
Gas pressure to appliance controls must never exceed 13.5" w.c. (1/2 psi).	Contrôles d'appareils à gaz février. Pression ne doit jamais dépasser 13.5" wc (1/2 psi).

⚠ WARNING/AVERTISSEMENT	
	
WATER AND REFRIGERANT SYSTEMS UNDER PRESSURE	EAU ET FRIGORIGÈNE EQUIPEMENTS SOUS PRESSION
<ul style="list-style-type: none"> Isolate/Lockout source and relieve pressure BEFORE servicing equipment. Failure to relieve pressure may result in property damage, serious bodily injury or death! 	<ul style="list-style-type: none"> Isoler la source / de verrouillage et de soulager la pression avant entretien de l'équipement. Le défaut de soulager la pression peut entraîner des dommages matériels, des blessures corporelles graves ou la mort!

General Information

⚠ WARNING/AVERTISSEMENT		
<p>Disconnect power supply (ies) before servicing. Refer servicing to qualified service personnel. Electric shock hazard. May result in injury or death!</p>		<p>Debrancher avant d'entreprendre le dépannage de l'appareil. Consulter un réparateur qualifié pour le dépannage. Risque de choc électrique. Résultat de mai dans dommages ou la mort!</p>
⚠ CAUTION/ATTENTION		
<p>Unit to be serviced by qualified personnel only. Refrigerant system under pressure. Relieve pressure before using torch. Recover refrigerant and store or dispose of properly.</p>		<p>Conifer la maintenance à un technicien qualifié. Le système frigorifique sous pression. Décompresser avant d'exposer à la flamme. Récupérer le frigorigène et le stocker ou le détruire correctement.</p>

CAUTION/ATTENTION	
<p>Use only copper conductors for field installed wiring. Unit terminals are not designed to accept other types of conductors.</p>	<p>Utilisez uniquement des conducteurs en cuivre pour le câblage. Bornes de l'unité ne sont pas conçus pour accepter d'autres types de conducteurs.</p>

ATTENTION
<p>To avoid the release of refrigerant into the atmosphere, the refrigerant circuit of this unit must be serviced only by technicians who meet local, state and federal proficiency requirements.</p> <p>All refrigerant discharged from this unit must be recovered WITHOUT EXCEPTION. Technicians must follow industry accepted guidelines and all local, state and federal statutes for the recovery and disposal of refrigerants.</p> <p>If a compressor is removed from the unit, system refrigerant circuit oil will remain in the compressor. To avoid leakage of compressor oil, the refrigerant lines of the compressor must be sealed after it is removed.</p>

⚠ WARNING/AVERTISSEMENT	
<p>Improper installation, adjustment, alteration, service or maintenance can cause injury or death. Read the installation, operating and maintenance instructions thoroughly before installing or servicing this equipment.</p>	<p>Inapproprié installation, un réglage, une modification, un service ou entretien peut causer des blessures ou la mort. Lisez minutieusement les instructions d'installation, d'exploitation et d'entretien avant d'installer ou de réparer ce matériel.</p>

⚠ WARNING/AVERTISSEMENT	
<p>To avoid possible injury or death due to electrical shock, open the power supply disconnect switch and secure it in an open position during installation.</p>	<p>Pour éviter les blessures ou la mort par électrocution, ouvrir la interrupteur de sécurité et fixez-le en position ouverte lors de l'installation.</p>

⚠ WARNING/AVERTISSEMENT	
<p>Use all lifting points. Improper lifting can cause property damage, severe personal injury, or death.</p>	<p>Utilisez tous les points de levage. Le levage incorrect peut entraîner des dommages matériels, des blessures graves ou la mort.</p>

⚠ WARNING/AVERTISSEMENT	
<p>Only trained and qualified personnel should be allowed to rig loads or operate load rated cranes and/or hoist assemblies. Do not use a forklift to lift or maneuver the unit. Failure to use load rated crane or hoist assembly to lift or maneuver the unit can cause severe personal injury and property damage.</p>	<p>Seul le personnel formé et qualifié est autorisé à soulever de l'équipement ou manoeuvrer des grues de cargaison et / ou équipements de levage. Ne pas utiliser un chariot élévateur pour soulever ou manoeuvrer l'appareil. Si vous n'utilisez pas a grue ou équipements de levage qualifiée pour soulever ou manoeuvrer l'unité peut causer de graves blessures corporelles et des dégâts matériels.</p>

ATTENTION
<p>This manual is specifically intended for qualified installation and service agencies trained to perform the installation and service of the rooftop unit.</p>

⚠ CAUTION/ATTENTION	
<p>What to do if you smell gas:</p> <ul style="list-style-type: none"> • Open windows if the appliance is located indoors • Don't touch electrical switches • Extinguish any open flame • Immediately call gas supplier 	<p>Que faire si vous sentez une odeur de gaz:</p> <ul style="list-style-type: none"> • Ouvrez les fenêtres si l'appareil se trouve à l'intérieur • Ne touchez pas aux interrupteurs électriques • Éteindre toute flamme • Appelez immédiatement votre fournisseur de gaz

CAUTION/ATTENTION	
<p>Excessive Chlorine, undissolved solids and other improper water conditions WILL DAMAGE the internal heat exchanger & WILL VOID YOUR WARRANTY!</p>	<p>Chlore excessive, solides non dissous et les autres impropres conditions de l'eau, ENDOMMAGERA l'échangeur de chaleur interne et ANNULERA VOTRE GARANTIE!</p>

General Information

⚠ WARNING/AVERTISSEMENT



<p>AVOID INJURY</p> <ul style="list-style-type: none"> Use extreme CAUTION when sliding or removing this object. Improper handling may result in property damage or serious bodily injury! 	<p>EVITER LES BLESSURES</p> <ul style="list-style-type: none"> Soyez extrêmement prudent lorsque vous faites glisser ou de retirer cet objet. Une mauvaise manipulation peut entraîner des dommages matériels ou des blessures corporelles graves!
--	---

ATTENTION

Remove shipping bolt(s) from supply and exhaust fan assemblies prior to startup.

ATTENTION

Rigging Instructions

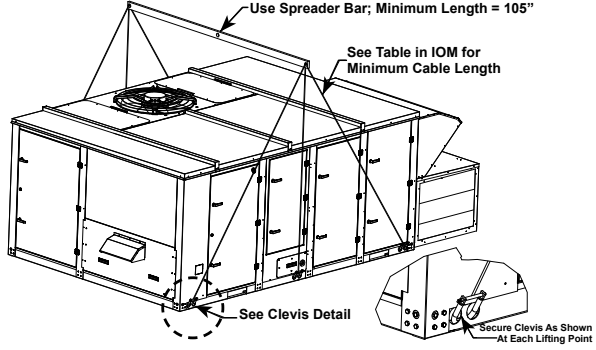

⚠ CAUTION/ATTENTION

3 PHASE SCROLL COMPRESSOR UNITS	UNITÉ DE COMPRESSEUR SCROLL 3-PHASE
<p>If this unit uses a 3 Phase Scroll Compressor, the following instructions MUST BE followed:</p> <ul style="list-style-type: none"> Unit power supply MUST BE wired in the proper sequence to avoid damage to the 3 Phase Scroll Compressor; Scroll Compressors with INCORRECT rotation show the following characteristics: <ul style="list-style-type: none"> - High sound level; - High suction pressure and low discharge pressure; - Low current draw. If any of the three above characteristics exist, swap two of the three supply wires at the disconnect and recheck compressor for incorrect rotation. 	<p>Si cet appareil utilise compresseur scroll 3-Phase, les instructions suivantes doivent être suivies:</p> <ul style="list-style-type: none"> L'alimentation de l'appareil doit être monté dans l'ordre correct pour éviter endommager le compresseur scroll 3-Phase Compresseurs scroll avec rotation incorrecte montrent les caractéristiques suivantes: <ul style="list-style-type: none"> - Haut niveau de son; - Pression d'aspiration élevée et une faible pression de décharge; - Faible ampérage Si l'un des trois éléments mentionnés ci-dessus sont remplies, échanger deux des trois lignes électriques alimentant l'interrupteur de sécurité et vérifier la rotation du compresseur.

CAUTION/ATTENTION

Single wall heat exchanger, not suitable for potable water connection.	Single paroi échangeur, non approprié pour le raccordement d'eau potable.
--	---

ATTENTION

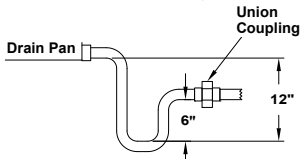
<p>Slide Out Drain Pan</p> 	<p>Condensate Drain Trapping</p>  <p>Union coupling required in installation to allow removal of drain pan.</p>
---	---

Code String

Component Description	Field	Code	Code Description		
Product Line	1	R	Rooftop		
Application Type	2	A	Air-Cooled AC (STD)		
		B	Water-Cooled AC		
		H	Air-Cooled HP		
		W	Water-Source HP		
		G	Geothermal HP		
		F	Chilled Water		
		S	Split Air-Cooled AC AHU (special)		
		Q	Split Air-Cooled HP AHU (special)		
		X	Special Quote		
Unit Size	3-4		2 Series	4 Series	8 Series
		06	Nominal 6 ton	NA	NA
		08	Nominal 7.5 ton	NA	NA
		10	Nominal 10 ton	NA	NA
		13	Nominal 12.5 ton	NA	NA
		15	Nominal 15 ton	NA	NA
		18	Nominal 17.5 ton	NA	NA
		20	Nominal 20 ton	NA	NA
		16	NA	Nominal 15 ton	NA
		21	NA	Nominal 20 ton	NA
		25	NA	Nominal 25 ton	NA
		30	NA	Nominal 30 ton	NA
		35	NA	Nominal 35 ton	NA
		40	NA	Nominal 40 ton	NA
		31	NA	NA	Nominal 30 ton
		41	NA	NA	Nominal 40 ton
		50	NA	NA	Nominal 50 ton
		60	NA	NA	Nominal 60 ton
		70	NA	NA	Nominal 70 ton
80	NA	NA	Nominal 80 ton		
Series (Generation)	5	A	1st Generation		
Compressor Type	6	A	Standard High Efficiency Compressors - R-410A All Circuits / 6 Row DX Coils (STD)		
		B	Variable Speed Compressors - R-410A All Circuits / 6 Row DX Coils		
		C	Variable Speed Compressor - R-410A Lead Circuit / 6 Row DX Coils		
		D	Digital Compressors - R-410A All Circuits / 6 Row DX Coils		
		E	Digital Compressor - R-410A Lead Circuit / 6 Row DX Coils		
		F	None - Chilled Water Application / 6 Row Chilled Water Coils		
		X	Special Quote		
Voltage	7	K	208/3/60		
		L	230/3/60		
		F	460/3/60 (STD)		
		N	575/3/60		
		X	Special Quote		
Airflow Configuration	8	A	Vertical Supply / Vertical Return (STD)		
		B	Vertical Supply / No Return		
		C	Horizontal Supply / Vertical Return		
		D	Horizontal Supply / No Return		
		E	Horizontal Supply / Horizontal Return (Special)		
		F	Vertical Supply / Horizontal Return (Special)		
		X	Special Quote		

Code String

Component Description	Field	Code	Code Description		
Dampers	9	A	Motorized O.A & R.A. 2-Position Dampers (STD)		
		B	Motorized O.A. 2-Position Damper		
		C	Modulating Enthalpy Economizer		
		D	Manual O.A. Damper		
		E	Manual O.A. & R.A. Dampers		
		F	No Dampers		
		X	Special Quote		
		Energy Recovery Wheel Size	10		2 Series
0	None			None	None
A	ECW364			NA	NA
B	ECW424			NA	NA
C	ECW484			ECW484	NA
D	ECW486			NA	NA
E	NA			ECW544	NA
F	NA			ECW604	ECW604
G	NA			ECW664	ECW664
H	NA			ECW706	NA
J	NA			NA	ECW724
K	NA			NA	ECW784
L	NA			NA	ECW844
M	NA			NA	ECW846
X	Special Quote			Special Quote	Special Quote
Energy Recovery Wheel Options	11	0	None		
		A	Defrost Control (Pulsing) (STD)		
		B	Defrost control (VFD)		
		C	Defrost Control (Pulsing) + Bypass Dampers		
		D	Defrost Control (VFD) + Bypass Dampers		
		X	Special Quote		
Supplemental Heating Option	12	0	None		
		A	Gas Heat - Low (Hi/Lo Gas Pressure Switch) - SS409		
		B	Gas Heat - Medium (Hi/Lo Gas Pressure Switch) - SS409		
		C	Gas Heat - Medium High (Hi/Lo Gas Pressure Switch) - SS409		
		D	Gas Heat - High (Hi/Lo Gas Pressure Switch) - SS409		
		E	Gas Heat - Low (Hi/Lo Gas Pressure Switch) - SS304		
		F	Gas Heat - Medium (Hi/Lo Gas Pressure Switch) - SS304		
		G	Gas Heat - Medium High (Hi/Lo Gas Pressure Switch) - SS304		
		H	Gas Heat - High (Hi/Lo Gas Pressure Switch) - SS304		
		J	Electric Heat - Low (Open Coil)		
		K	Electric heat - Medium (Open Coil)		
		L	Electric Heat - Medium High (Open Coil)		
		M	Electric Heat - High (Open Coil)		
		N	Electric Heat - Low (Finned Tube) (Special)		
		P	Electric heat - Medium (Finned Tube) (Special)		
		Q	Electric Heat - Medium High (Finned Tube) (Special)		
		R	Electric Heat - High (Finned Tube) (Special)		
		S	1 Row Hot Water Coil (Reheat Position)		
		T	2 Row Hot Water Coil (ReHeat Position)		
		U	1 Row Steam Coil (Reheat Position) - no freeze, steam distributing type		
		V	1 Row Steam Coil (Pre-Heat Position) - no freeze, steam distributing type		
		W	1 Row Hot Water Coil (Pre-Heat Position)		
		Y	2 Row Hot Water Coil (Pre-Heat Position)		
		X	Special Quote		

Code String

Component Description	Field	Code	Code Description		
Control Method For Supplemental Heating Option	13	0	None		
		A	Modulating control for Gas Heat (No Compressor Running Simultaneously)		
		B	SCR control for Electric Heat (No Compressor Running Simultaneously)		
		C	Modulating Control for Hot Water Coils (No Compressor Running Simultaneously)		
		D	Modulating Control for Steam Coils (No Compressor Running Simultaneously)		
		2	Modulating control for Gas Heat (Compressor Running Simultaneously) (Special)		
		3	SCR control for Electric Heat (Compressor Running Simultaneously) (Special)		
		4	Modulating Control for Hot Water Coils (Compressor Running Simultaneously) (Special)		
		5	Modulating Control for Steam Coils (Compressor Running Simultaneously) (Special)		
X	Special Quote				
Supply Blower	14		2 Series	4 Series	8 Series
		A	(1) DDP105-9-120	NA	NA
		B	(1) DDP150-9-120	(1) DDP150-9-120	NA
		C	(1) DDP165-9-120	(1) DDP165-9-120	(2) DDP165-9-120
		D	(1) DDP182-9-120	(1) DDP182-9-120	(2) DDP182-9-120
		E	NA	(1) DDP222-9-120	(2) DDP222-9-120
		F	NA	(1) DDP245-9-120	(2) DDP245-9-120
		G	NA	(1) DDP270-9-120	(2) DDP270-9-120
		X	Special Quote	Special Quote	Special Quote
Supply Blower Motor	15	A	(1) 1 HP 1200 RPM	(1) 1 HP 1200 RPM	(2) 1 HP 1200 RPM
		B	(1) 2 HP 1200 RPM	(1) 2 HP 1200 RPM	(2) 2 HP 1200 RPM
		C	(1) 3 HP 1200 RPM	(1) 3 HP 1200 RPM	(2) 3 HP 1200 RPM
		D	(1) 5 HP 1200 RPM	(1) 5 HP 1200 RPM	(2) 5 HP 1200 RPM
		E	(1) 7.5 HP 1200 RPM	(1) 7.5 HP 1200 RPM	(2) 7.5 HP 1200 RPM
		F	(1) 10 HP 1200 RPM	(1) 10 HP 1200 RPM	(2) 10 HP 1200 RPM
		G	(1) 15 HP 1200 RPM	(1) 15 HP 1200 RPM	(2) 15 HP 1200 RPM
		H	(1) 20 HP 1200 RPM	(1) 20 HP 1200 RPM	(2) 20 HP 1200 RPM
		J	(1) 25 HP 1200 RPM	(1) 25 HP 1200 RPM	(2) 25 HP 1200 RPM
		K	(1) 1 HP 1800 RPM	(1) 1 HP 1800 RPM	(2) 1 HP 1800 RPM
		L	(1) 2 HP 1800 RPM	(1) 2 HP 1800 RPM	(2) 2 HP 1800 RPM
		M	(1) 3 HP 1800 RPM	(1) 3 HP 1800 RPM	(2) 3 HP 1800 RPM
		N	(1) 5 HP 1800 RPM	(1) 5 HP 1800 RPM	(2) 5 HP 1800 RPM
		P	(1) 7.5 HP 1800 RPM	(1) 7.5 HP 1800 RPM	(2) 7.5 HP 1800 RPM
		Q	(1) 10 HP 1800 RPM	(1) 10 HP 1800 RPM	(2) 10 HP 1800 RPM
		R	(1) 15 HP 1800 RPM	(1) 15 HP 1800 RPM	(2) 15 HP 1800 RPM
		S	(1) 20 HP 1800 RPM	(1) 20 HP 1800 RPM	(2) 20 HP 1800 RPM
T	(1) 25 HP 1800 RPM	(1) 25 HP 1800 RPM	(2) 25 HP 1800 RPM		
X	Special Quote	Special Quote	Special Quote		
Power Exhaust Blower	16		2 Series	4 Series	8 Series
		0	None	None	None
		A	(1) DDP105-9-120	NA	NA
		B	(1) DDP150-9-120	(1) DDP150-9-120	NA
		C	(1) DDP165-9-120	(1) DDP165-9-120	(2) DDP165-9-120
		D	(1) DDP182-9-120	(1) DDP182-9-120	(2) DDP182-9-120
		E	NA	(1) DDP222-9-120	(2) DDP222-9-120
		F	NA	(1) DDP245-9-120	(2) DDP245-9-120
		G	NA	(1) DDP270-9-120	(2) DDP270-9-120
		X	Special Quote	Special Quote	Special Quote

Code String

Component Description	Field	Code	Code Description		
Power Exhaust Blower Motor	17		2 Series	4 Series	8 Series
		0	None	None	None
		A	(1) 1 HP 1200 RPM	(1) 1 HP 1200 RPM	(2) 1 HP 1200 RPM
		B	(1) 2 HP 1200 RPM	(1) 2 HP 1200 RPM	(2) 2 HP 1200 RPM
		C	(1) 3 HP 1200 RPM	(1) 3 HP 1200 RPM	(2) 3 HP 1200 RPM
		D	(1) 5 HP 1200 RPM	(1) 5 HP 1200 RPM	(2) 5 HP 1200 RPM
		E	(1) 7.5 HP 1200 RPM	(1) 7.5 HP 1200 RPM	(2) 7.5 HP 1200 RPM
		F	(1) 10 HP 1200 RPM	(1) 10 HP 1200 RPM	(2) 10 HP 1200 RPM
		G	(1) 15 HP 1200 RPM	(1) 15 HP 1200 RPM	(2) 15 HP 1200 RPM
		H	(1) 20 HP 1200 RPM	(1) 20 HP 1200 RPM	(2) 20 HP 1200 RPM
		J	(1) 25 HP 1200 RPM	(1) 25 HP 1200 RPM	(2) 25 HP 1200 RPM
		K	(1) 1 HP 1800 RPM	(1) 1 HP 1800 RPM	(2) 1 HP 1800 RPM
		L	(1) 2 HP 1800 RPM	(1) 2 HP 1800 RPM	(2) 2 HP 1800 RPM
		M	(1) 3 HP 1800 RPM	(1) 3 HP 1800 RPM	(2) 3 HP 1800 RPM
		N	(1) 5 HP 1800 RPM	(1) 5 HP 1800 RPM	(2) 5 HP 1800 RPM
		P	(1) 7.5 HP 1800 RPM	(1) 7.5 HP 1800 RPM	(2) 7.5 HP 1800 RPM
		Q	(1) 10 HP 1800 RPM	(1) 10 HP 1800 RPM	(2) 10 HP 1800 RPM
		R	(1) 15 HP 1800 RPM	(1) 15 HP 1800 RPM	(2) 15 HP 1800 RPM
		S	(1) 20 HP 1800 RPM	(1) 20 HP 1800 RPM	(2) 20 HP 1800 RPM
		T	(1) 25 HP 1800 RPM	(1) 25 HP 1800 RPM	(2) 25 HP 1800 RPM
X	Special Quote	Special Quote	Special Quote		
Filters	18	A	2 In. Pleated MERV 8 Filters (STD)		
		B	4 In. Pleated MERV 8 Filters		
		C	4 In. Pleated MERV 13 Filters		
		D	4 In. Pleated MERV 14 Filters		
		E	2 In. MERV 8 plus 4 In. MERV 8		
		F	2 In. MERV 8 plus 4 In. MERV 13		
		G	2 In. MERV 8 plus 4 In. MERV 14		
		2	2 In. Pleated MERV 8 Filters With Dirty Filter Indicator		
		3	4 In. Pleated MERV 8 Filters With Dirty Filter Indicator		
		4	4 In. Pleated MERV 13 Filters With Dirty Filter Indicator		
		5	4 In. Pleated MERV 14 Filters With Dirty Filter Indicator		
		6	2 In. MERV 8 plus 4 In. MERV 8 With Dirty Filter Indicator		
		7	2 In. MERV 8 plus 4 In. MERV 13 With Dirty Filter Indicator		
		8	2 In. MERV 8 plus 4 In. MERV 14 With Dirty Filter Indicator		
		X	Special Quote		
Hot Gas Reheat	19	0	None		
		A	Modulating HGRH - All Circuits		
		B	Modulating HGRH - Lead Circuit		
		C	Modulating HGRH - All Circuits w/ Stainless Steel Coil Casing (Special)		
		D	Modulating HGRH - Lead Circuit w/ Stainless Steel Coil Casing (Special)		
		X	Special Quote		
Liquid Subcooling	20	0	None		
		A	Liquid Subcooling Constant - All Circuits		
		B	Liquid Subcooling Switchable - All Circuits		
		X	Special Quote		

Code String

Component Description	Field	Code	Code Description
Hot Gas Bypass	21	0	None
		A	Hot Gas Bypass - All Circuits
		B	Hot Gas Bypass - Lag Circuit (Special)
		C	Hot Gas Bypass - Lead Circuit (Special)
		X	Special Quote
Condenser Contraction Options	22	0	None
		A	Condenser Coil Coating
		B	Condenser Coil Guard
		C	Condenser Coil Hail Guard
		D	Condenser Coil Coating and Coil Guard
		E	Condenser Coil Coating and Hail Guard
		F	SMO Water-Cooled Condenser (Special)
		G	Heat Trace - For STD Water-Cooled Condenser (Special)
		H	Heat Trace - For SMO Water-Cooled Condenser (Special)
		X	Special Quote
Evaporator Contraction Options	23	0	None
		A	Evaporator Coil Coating
		B	Stainless Steel Evap Coil Casing
		C	Evaporator Coil Coating & Stainless Steel Evap Coil Casing
		2	Intertwined Evaporator Coils for VAV Application (Special)
		3	2 + A (Special)
		4	2 + B (Special)
		5	2 + C (Special)
		X	Special Quote
DDC Control	24	A	Standard Controls (DDC) (STD)
		B	Terminal Strip (Controls by others - Field Installed)
		C	Terminal Strip (Controls by others - Factory Installed)
		S	Split Condensing Unit Control (DDC)
		X	Special Quote
Operating Logic	25	A	Makeup Air Control
		B	Recirculating Unit Control
		C	CO2 Demand Control (Special)
		D	VAV Control
		X	Special Quote
Airflow Measurement	26	0	None
		A	Airflow Measurement Readout (ClimaCool DDC Control)
		B	Airflow Measurement Readout (DDC Control by Others)
		X	Special Quote
Phase Monitor	27	0	None
		A	Phase Monitor
		X	Special Quote
Firestat + Smoke Detector Terminal	28	0	None
		A	Firestat + Smoke Detector Terminal
		X	Special Quote

Code String

Component Description	Field	Code	Code Description
GFI Outlet	29	0	None
		A	115 V GFI Outlet (field powered)
		B	115 V GFI Outlet (unit powered)
		X	Special Quote
Disconnect	30	0	None
		A	30 Amp Non-Fused Main Disconnect
		B	60 Amp Non-Fused Main Disconnect
		C	100 Amp Non-Fused Main Disconnect
		D	200 Amp Non-Fused Main Disconnect
		E	400 Amp Non-Fused Main Disconnect
		F	600 Amp Non-Fused Main Disconnect
		X	Special Quote

Pre-Installation

Receiving Inspection

Upon receipt of the equipment, carefully check all items against the bill of lading to be sure all crates and cartons have been received. All units should be carefully inspected for any damage incurred during shipment. The carrier must make proper notation of any damage or shortage on all copies of the bill of lading and complete a carrier inspection report prior to your final acceptance of the shipment.

Note: It is the responsibility of the consignee to file all necessary claims with the carrier. Before unloading the unit, check the unit nameplate to make sure the voltage complies with the power supply available.

Handling of Units

Rigging holes for clevis hangers are provided on the unit base for placement of unit with a crane. Please see Rigging and Handling on page 22.

Storage

If installation will not occur immediately following delivery and units are stored on the ground, additional safeguards must be taken:

- Units must be placed on a level ground surface.
- Provide proper drainage around the unit to prevent flooding of the equipment.
- All doors must be closed and latched.
- Units must be covered and protected from construction traffic, debris and vandalism.
- Secure all field installed accessories shipped with the units.

Warranty

To ensure proper equipment longevity, design performance and reliability, all ClimaCool rooftop products must be installed, operated and maintained in accordance with ClimaCool IO&M manuals.

Startup

A factory trained technician is required to perform the startup of your ClimaCool rooftop unit. Please contact the Technical Service Department at 405-815-3000 or technicalsupport@climacoolcorp.com to schedule. **There is a minimum of three (3) weeks notice required to schedule a factory startup.**

ATTENTION

This manual is specifically intended for qualified installation and service agencies trained to perform the installation and service of the rooftop unit.

Dimensional Drawings - 2 Series Air Cooled

Figure 1 - Air Cooled Standard Cabinet - Vertical Supply, No Return

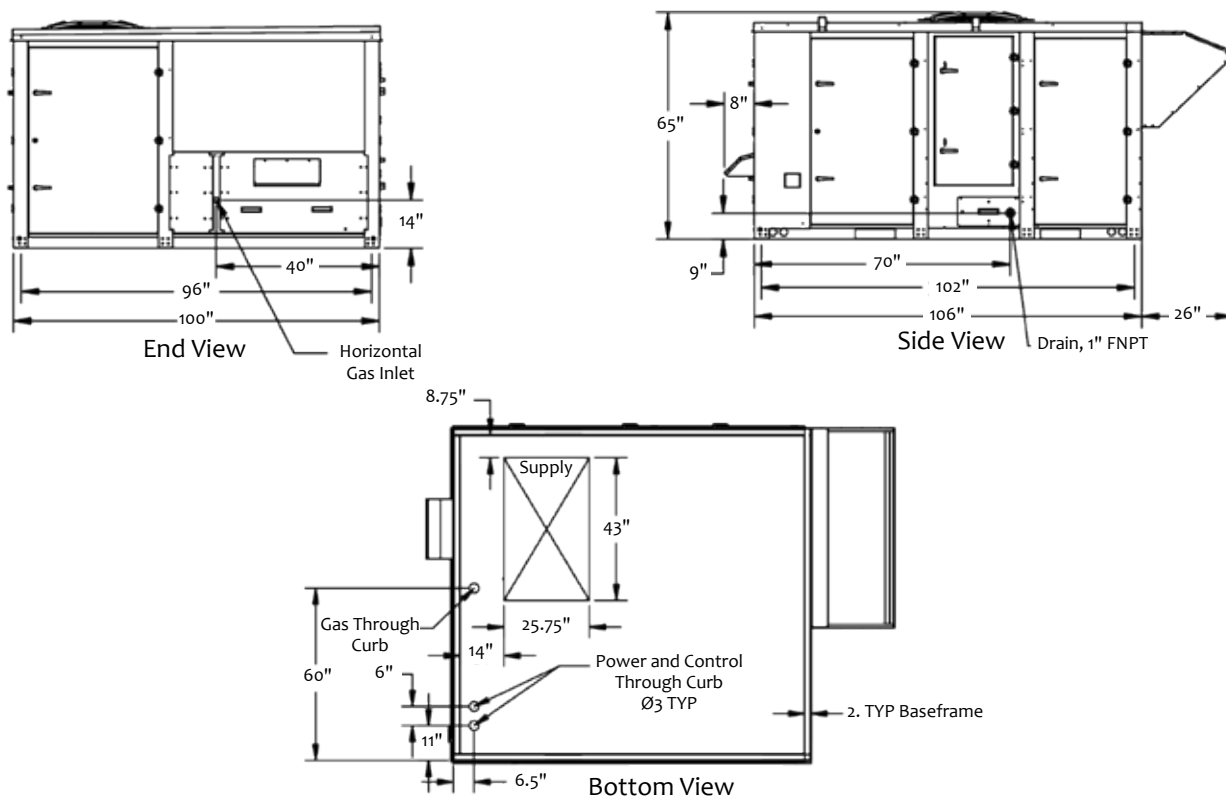
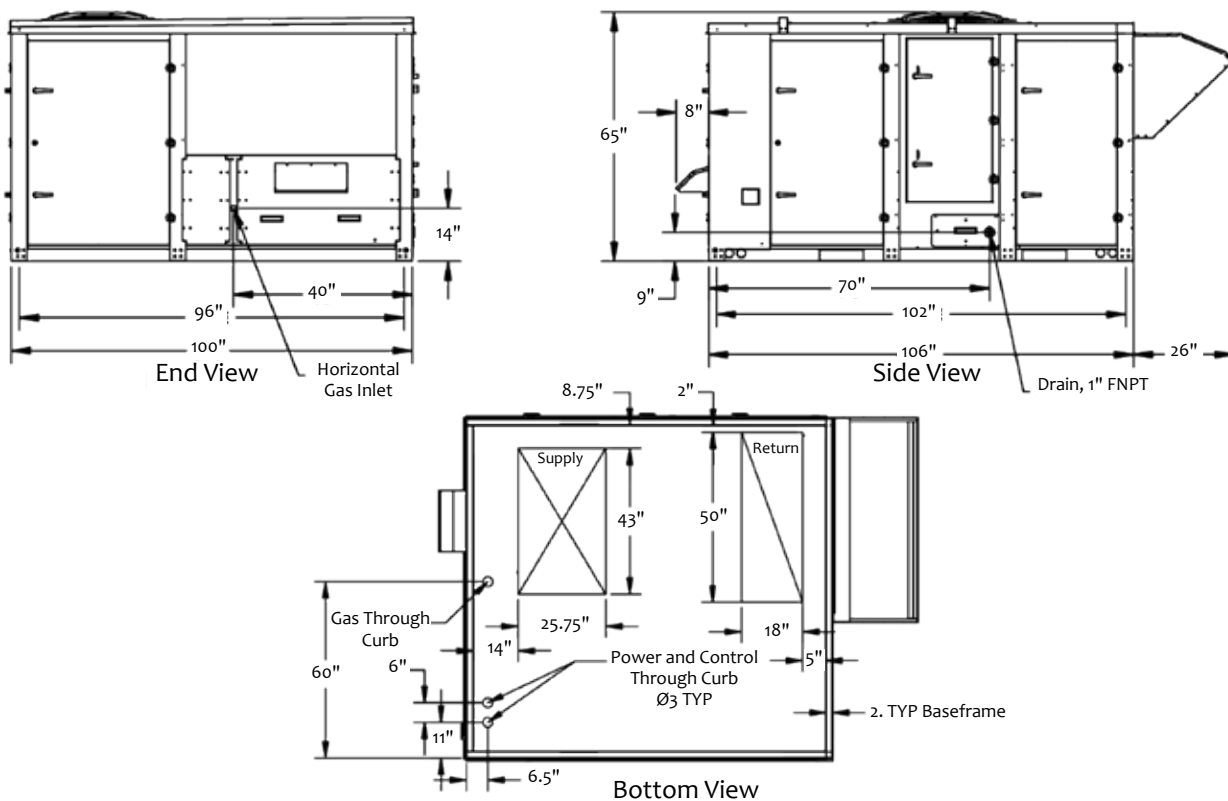

Figure 2 - Air Cooled Standard Cabinet - Vertical Supply & Return



Dimensional Drawings - 2 Series Water Cooled

Figure 5- Water Cooled Standard Cabinet - Vertical Supply, No Return

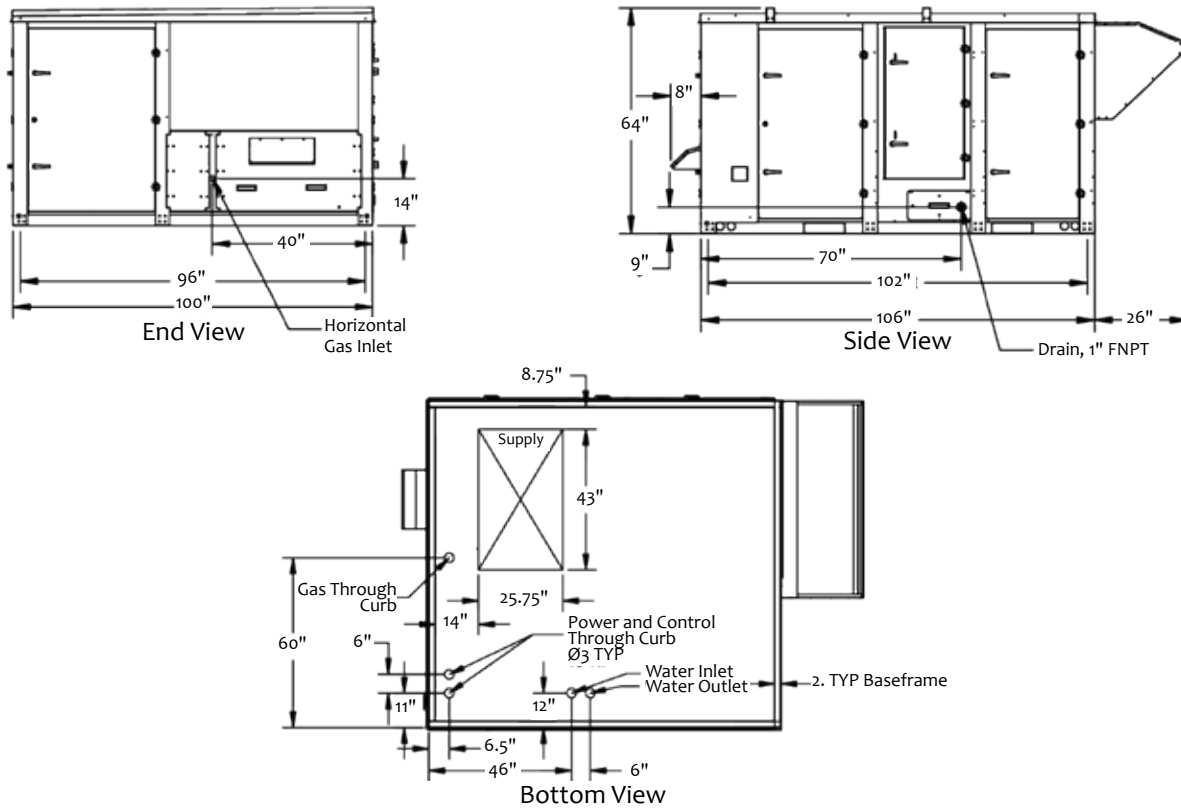
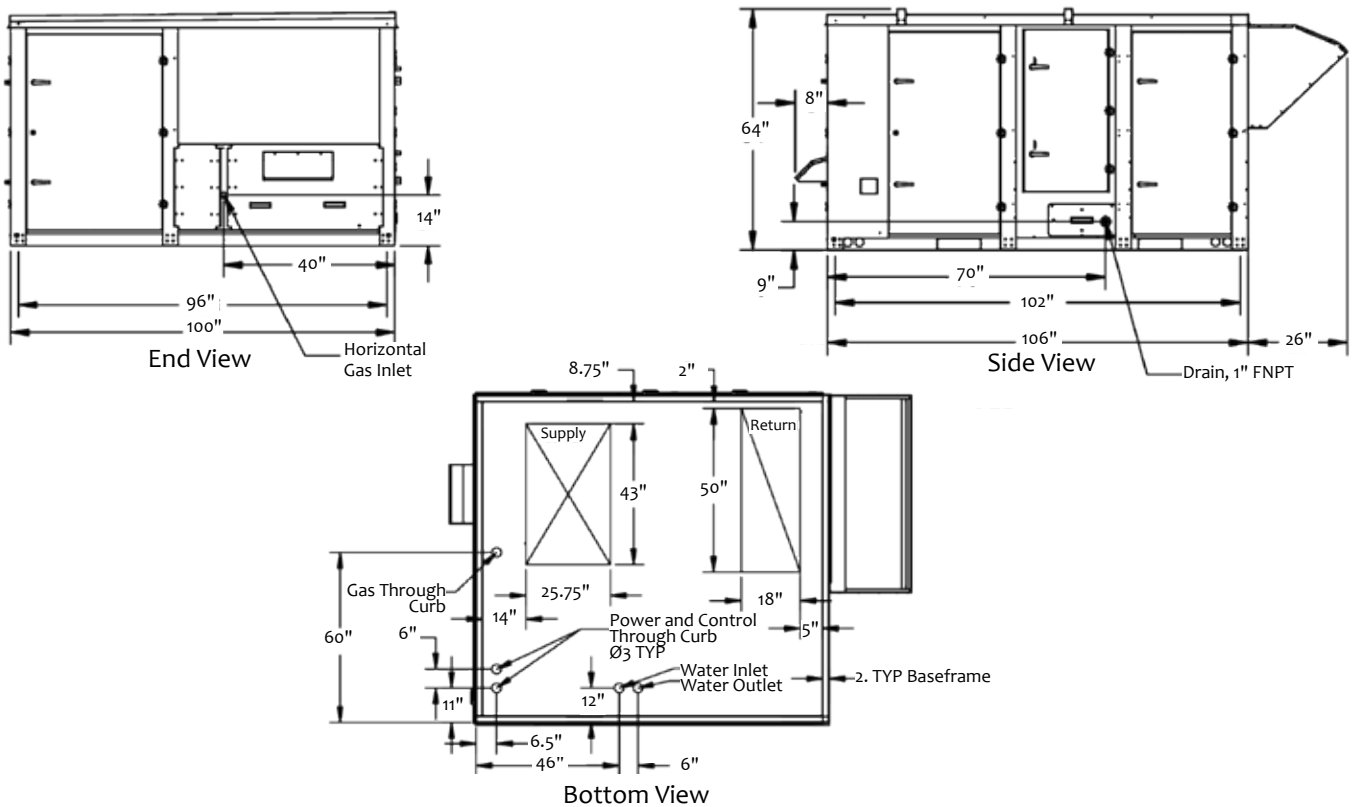

Figure 6 - Water Cooled Standard Cabinet - Vertical Supply & Return



Dimensional Drawings - 2 Series Water Cooled

Figure 7 - Water Cooled with Power Exhaust - Vertical Supply & Return

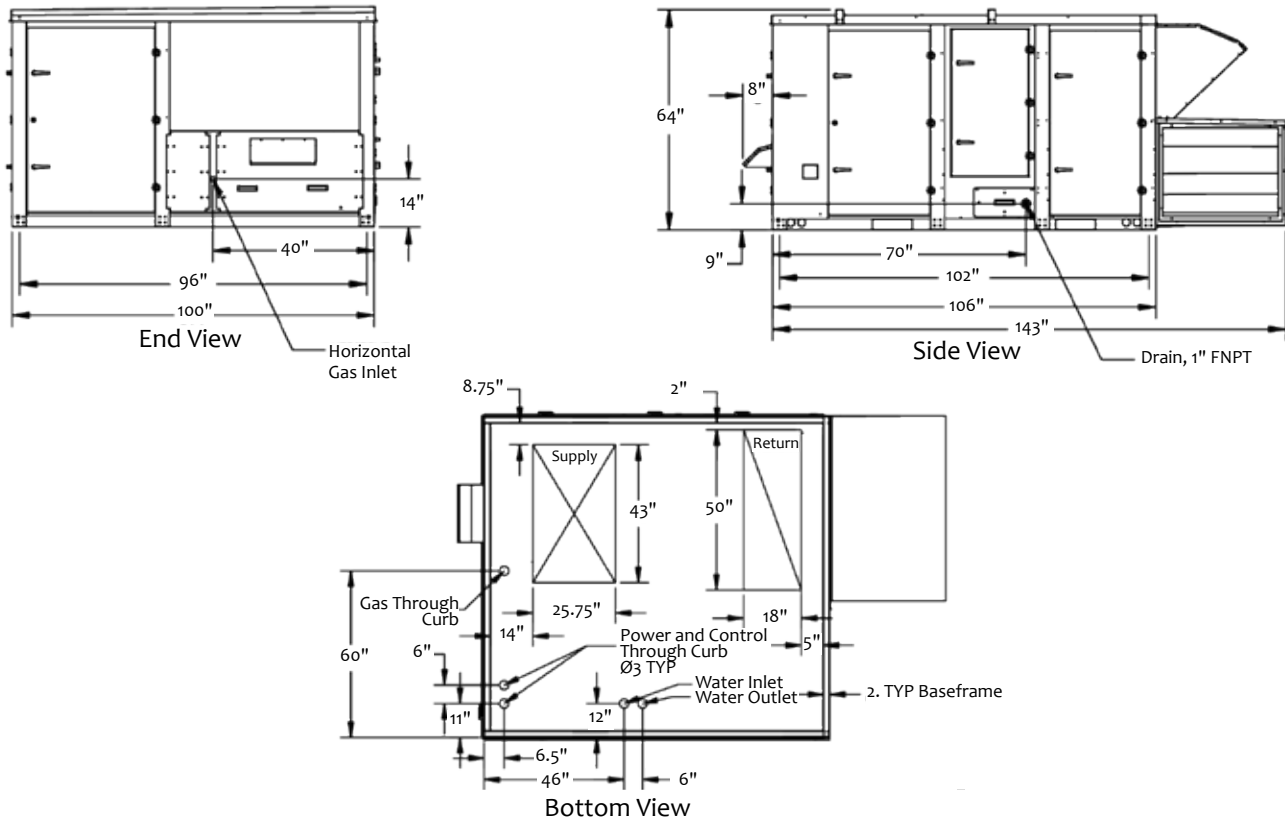
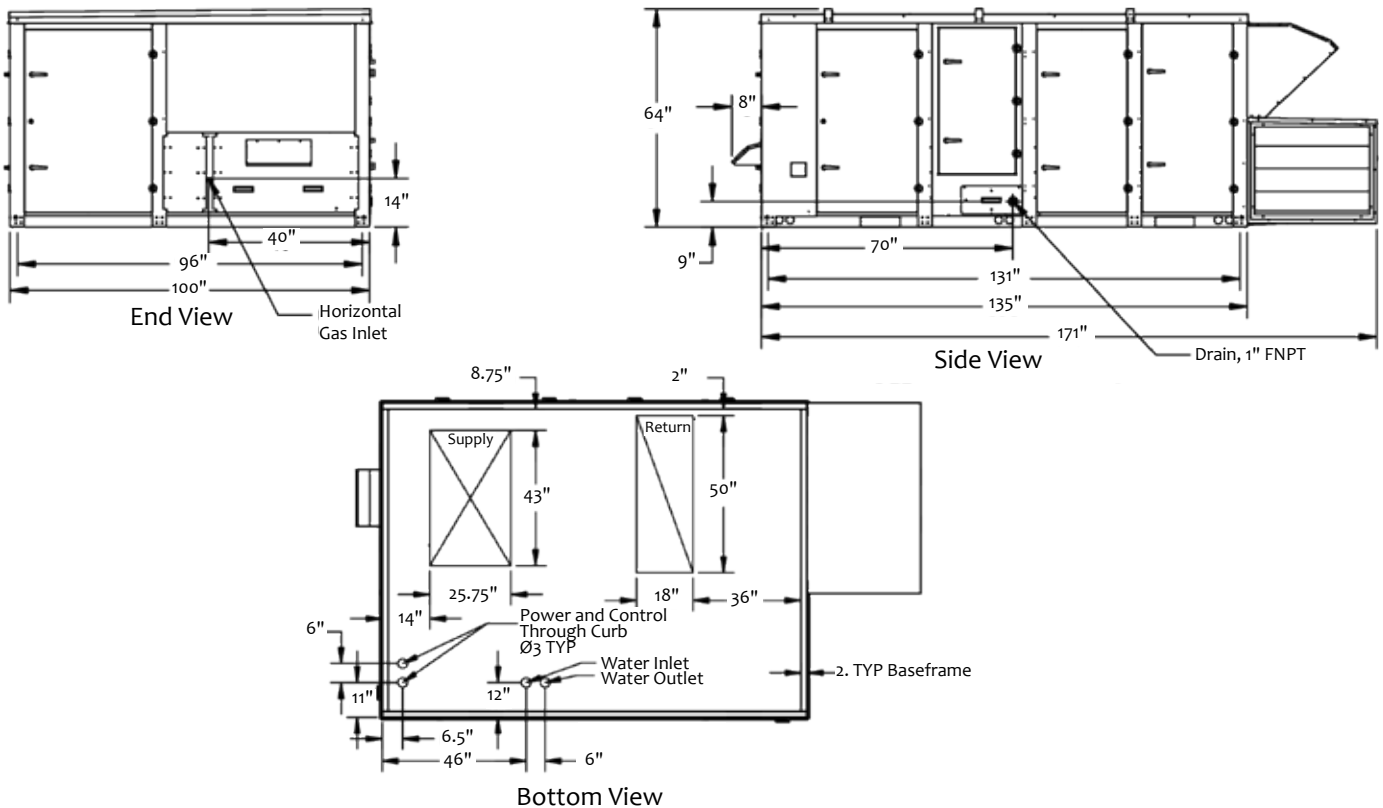

Figure 8 - Water Cooled with ECW Wheel and Power Exhaust - Vertical Supply & Return



Dimensional Drawings - 4 Series Air Cooled

Figure 9 - Air Cooled Standard Cabinet - Vertical Supply, No Return

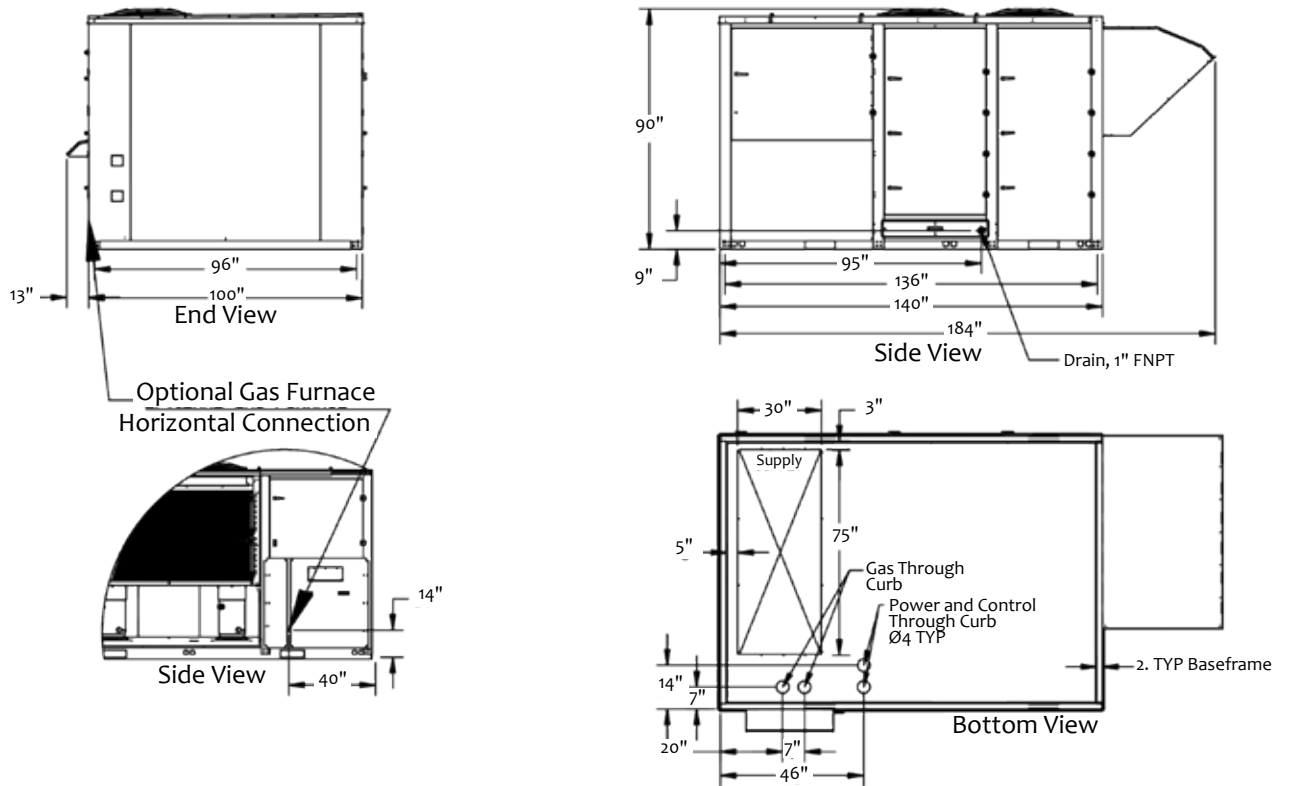
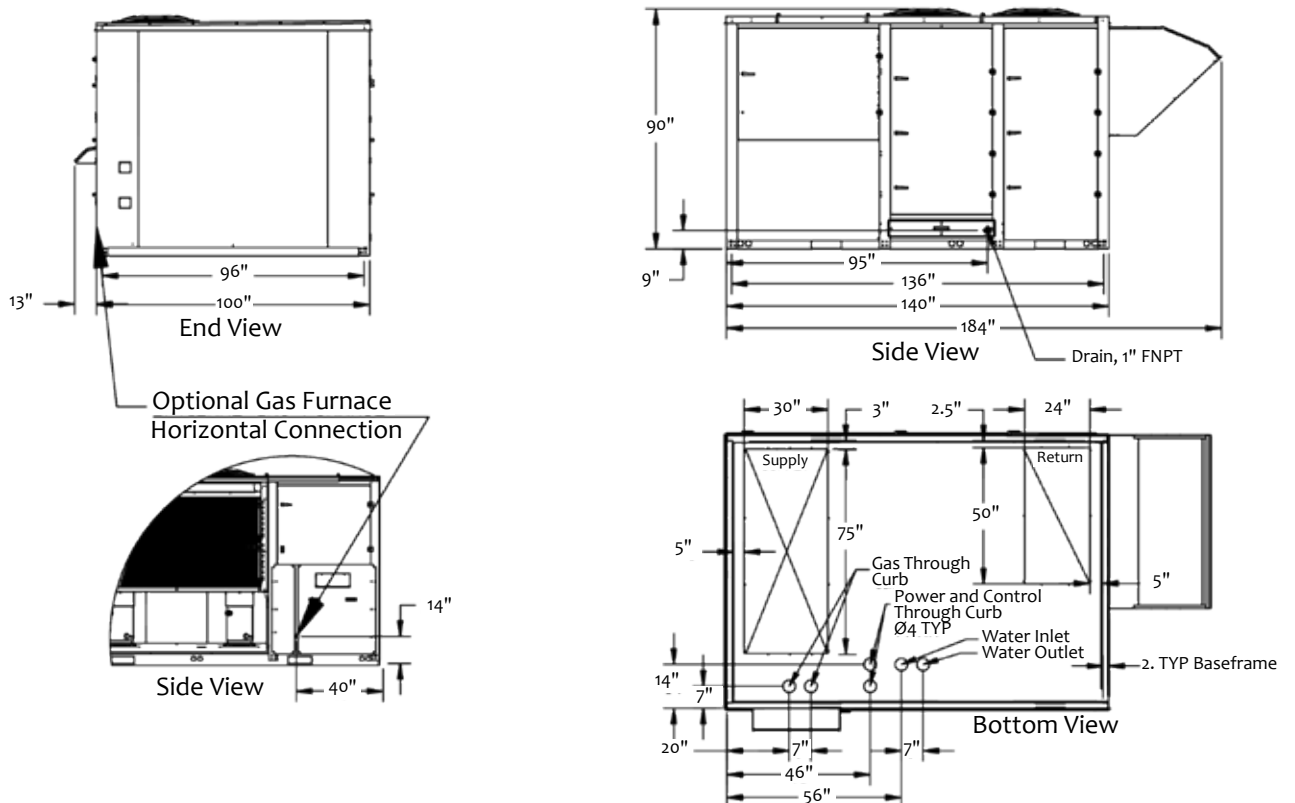

Figure 10 - Air Cooled Standard Cabinet - Vertical Supply & Return



Dimensional Drawings - 4 Series Air Cooled

Figure 11 - Air Cooled with Power Exhaust - Vertical Supply & Return

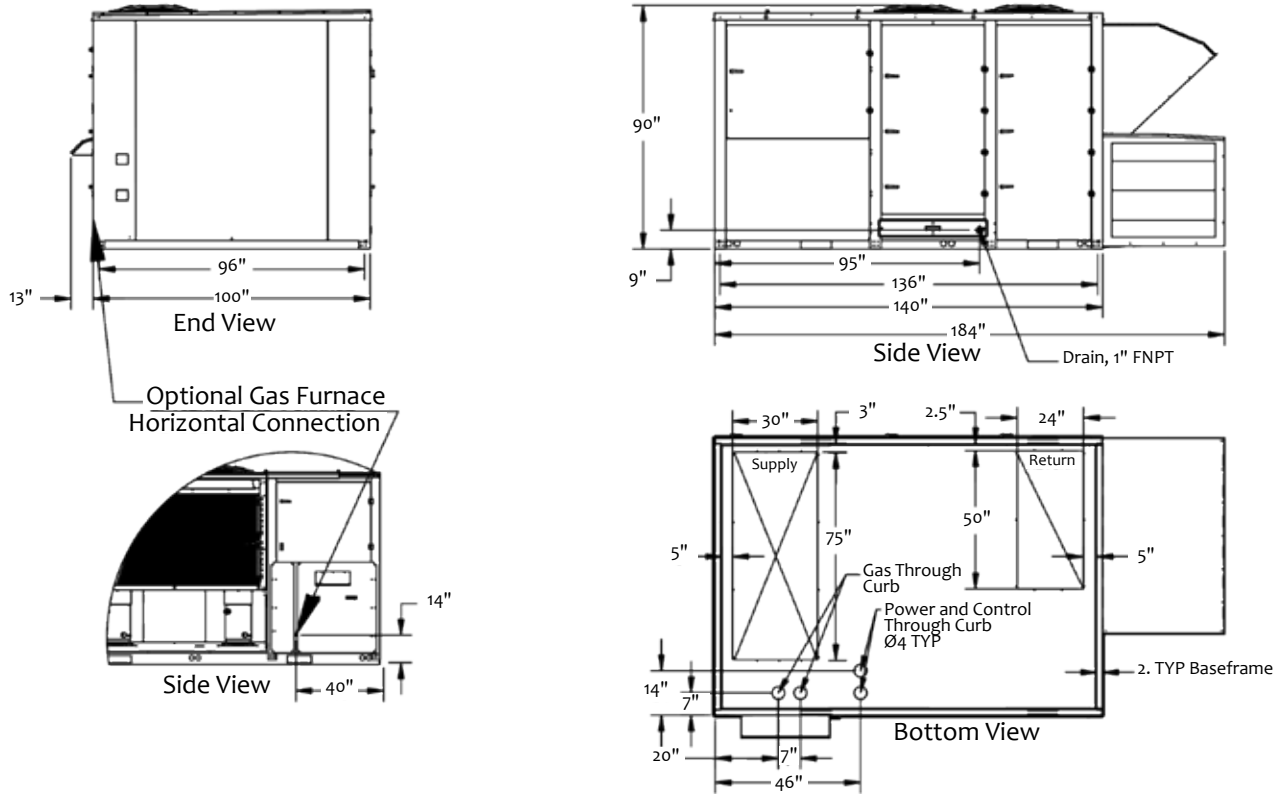
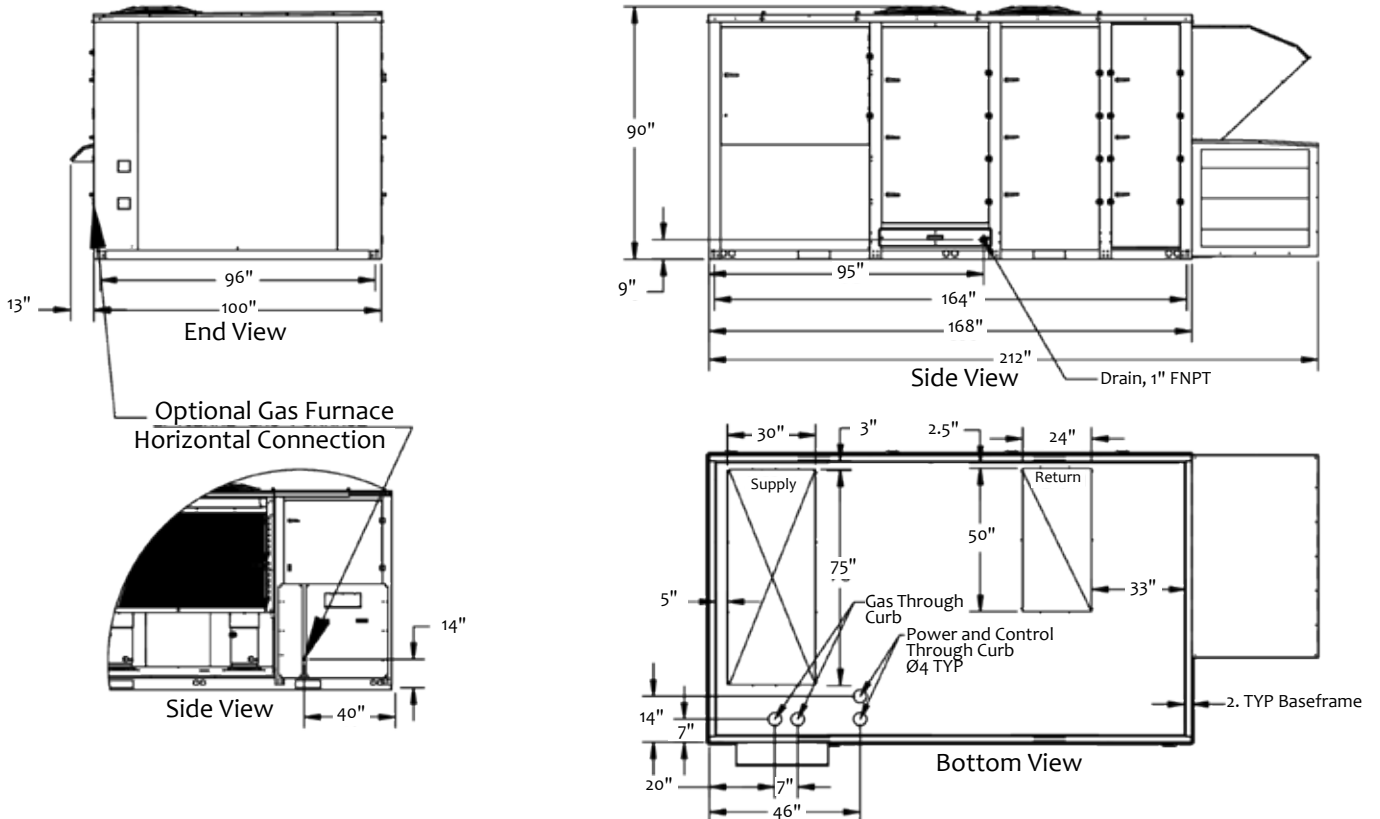

Figure 12 - Air Cooled with ECW Wheel, Power Exhaust - Vertical Supply & Return



Dimensional Drawings - 4 Series Water Cooled

Figure 13 - Water Cooled Standard Cabinet - Vertical Supply, No Return

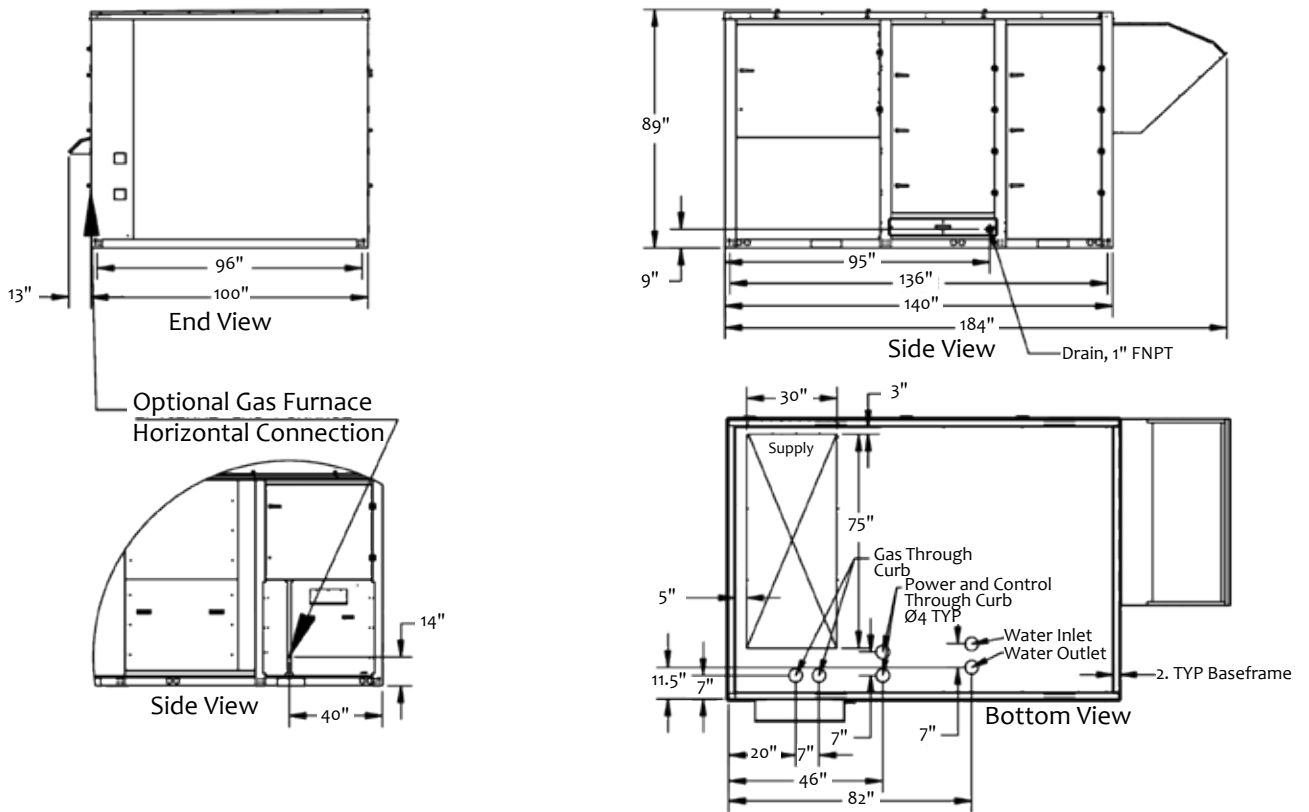
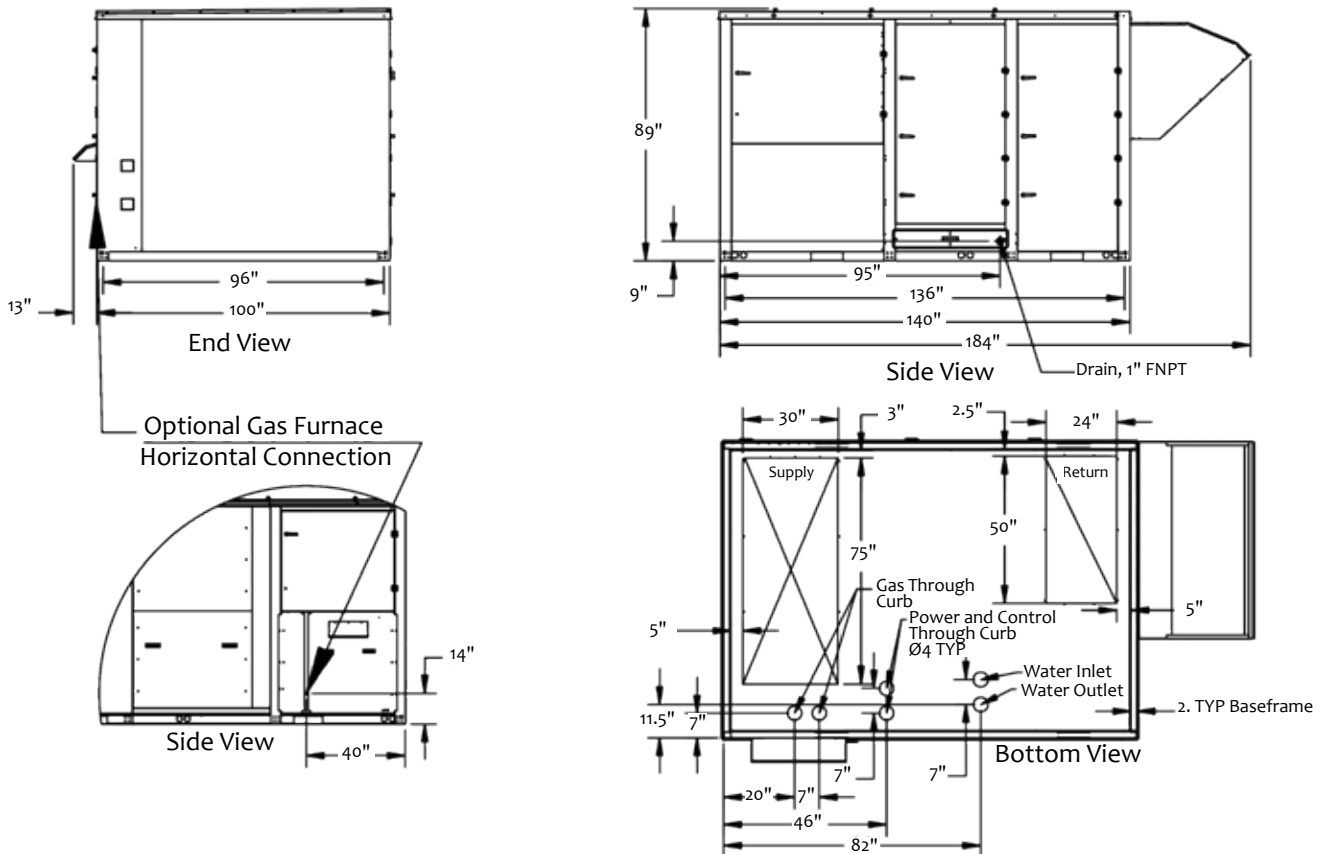

Figure 14 - Water Cooled Standard Cabinet - Vertical Supply & Return



Dimensional Drawings - 4 Series Water Cooled

Figure 15 - Water Cooled with Power Exhaust - Vertical Supply & Return

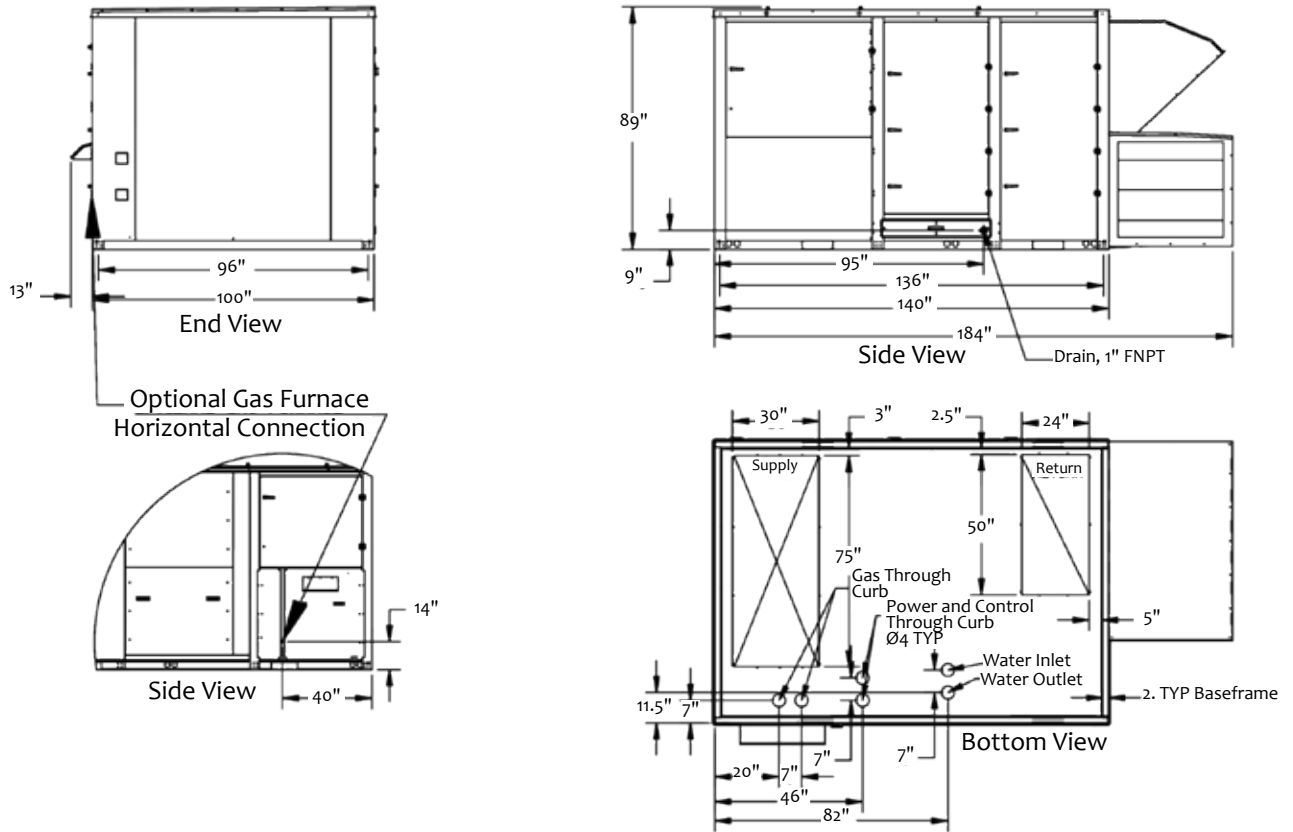
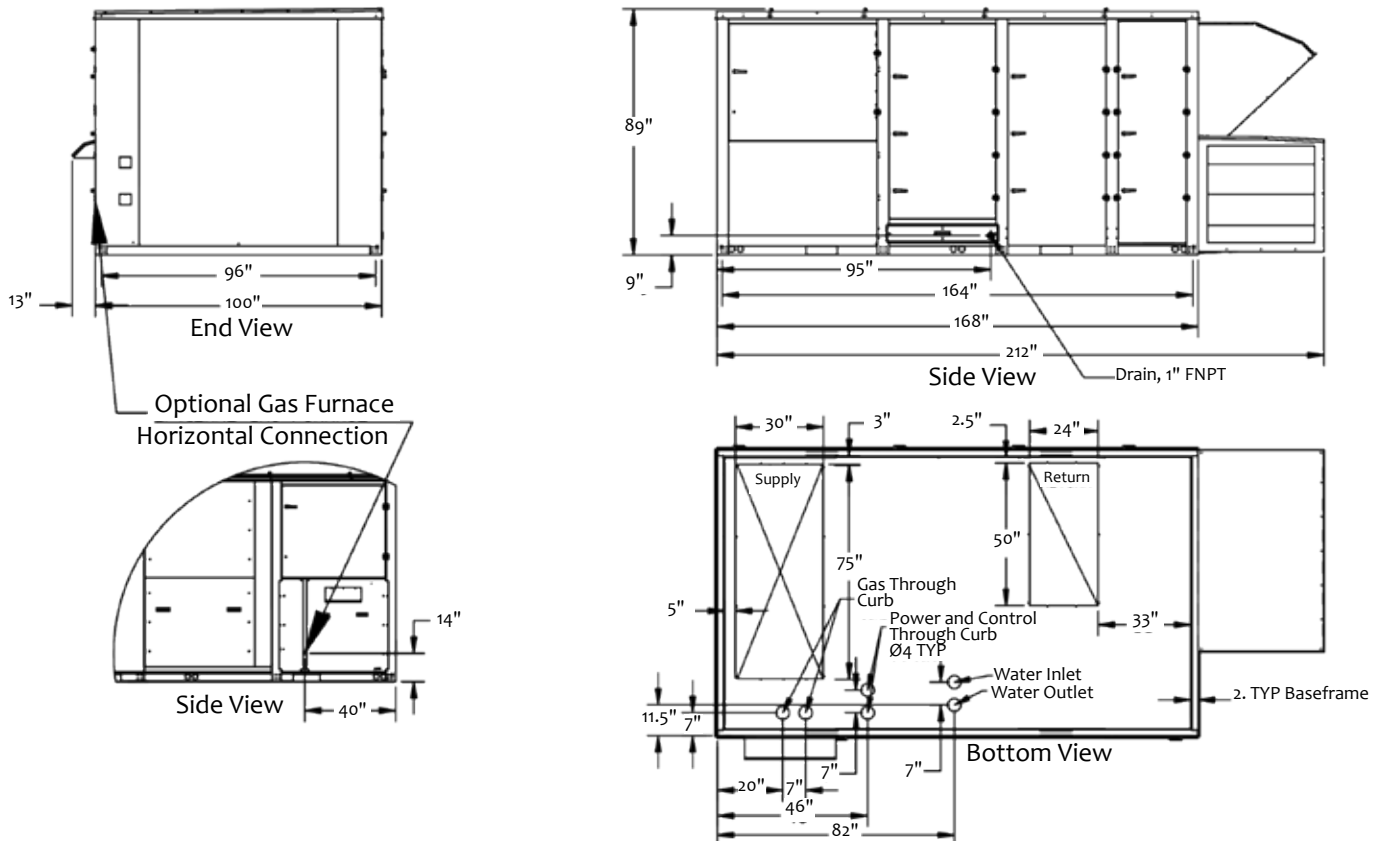

Figure 16 - Water Cooled with ECW Wheel, Power Exhaust - Vertical Supply & Return



Unit Installation

The customer must provide trained and experienced installers to follow local safety requirements when installing or servicing equipment. Conforming to applicable local and national codes is the responsibility of the installing contractor.

Service Clearance and Ventilation

Allow service and ventilation clearances as indicated in Figures 17 - 20. It is imperative to consider each application and provide adequate ventilation or the unit may not perform properly. Local codes will supersede the following restrictions:

1. All flue discharge vents must be at least 120" away from a fresh air intake of another piece of equipment.
2. Unit should be installed so that the flow of combustion intake air entering through the furnace intake hood is not obstructed.
3. Distance between any two units: 2 Series allow 108" between each unit, 4 Series allow 120" between each unit.

4. Units surrounded by solid walls: 2 Series allow 108" between the unit and the wall, 4 Series allow 120" between the unit and the wall.
5. Air Cooled installations must be unobstructed above the condenser fan(s) to allow vertical air discharge.
6. Refer to National Electrical Codes (N.E.C.) and local building codes which may require additional clearance.
7. To maintain adequate head pressure control at low outdoor air temperatures with windy conditions, install wind baffles around the unit.

CAUTION/ATTENTION	
What to do if you smell gas: <ul style="list-style-type: none"> • Open windows if the appliance is located indoors • Don't touch electrical switches • Extinguish any open flame • Immediately call gas supplier 	Que faire si vous sentez une odeur de gaz: <ul style="list-style-type: none"> • Ouvrez les fenêtres si l'appareil se trouve à l'intérieur • Ne touchez pas aux interrupteurs électriques • Éteignez toute flamme • Appelez immédiatement votre fournisseur de gaz

CAUTION/ATTENTION	
The presence of chlorine vapors in the combustion air supplied to gas-fired heaters presents a substantial corrosion hazard.	La présence de vapeurs de chlore dans l'air de combustion fourni à ce four a un haut risque de corrosion.

CAUTION/ATTENTION	
Flue gases must be directed away from combustion air inlets to avoid recirculation into combustion air supply.	Les gaz de combustion doivent être dirigés loin de prises d'air de combustion pour éviter la recirculation dans l'alimentation en air de combustion.

Figure 17 - Top View, 2 Series, Air Cooled Cabinet

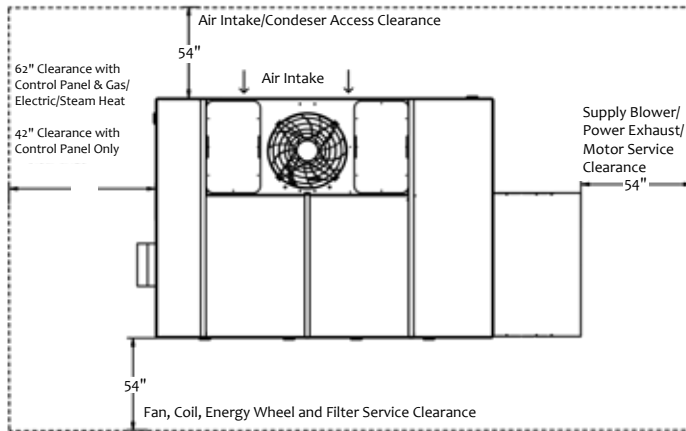

Figure 18 - Top View, 2 Series, Water Cooled Cabinet

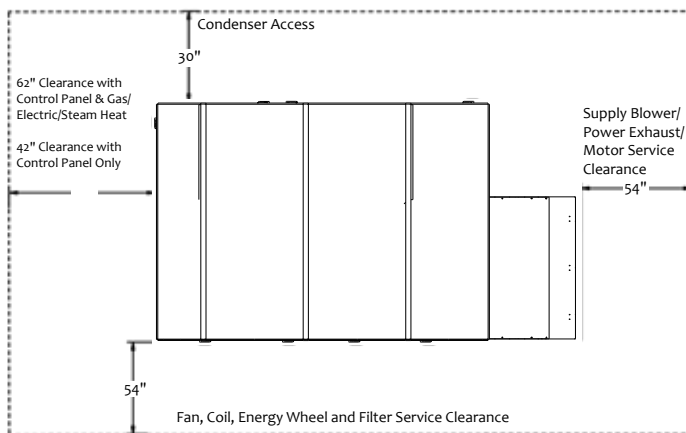

Figure 19 - Top View, 4 Series, Air Cooled Cabinet

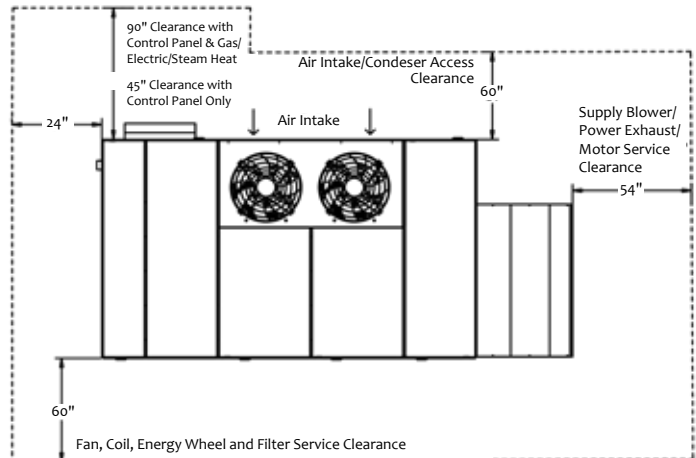
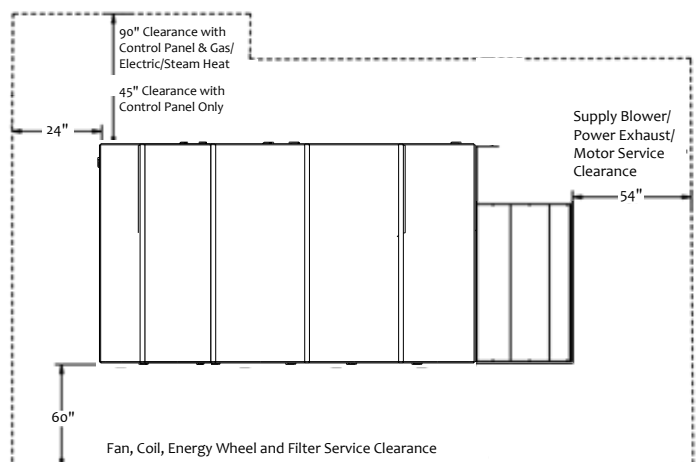

Figure 20 - Top View, 4 Series, Water Cooled Cabinet



Unit Installation

Roof Curb Assembly and Installation

Please refer to the instructions included with the roof curb for assembly installation.

Figure 21 - Roof Curb Assembly – 2 Series, Air Cooled & Water Cooled Standard Cabinet - 14" and 24"

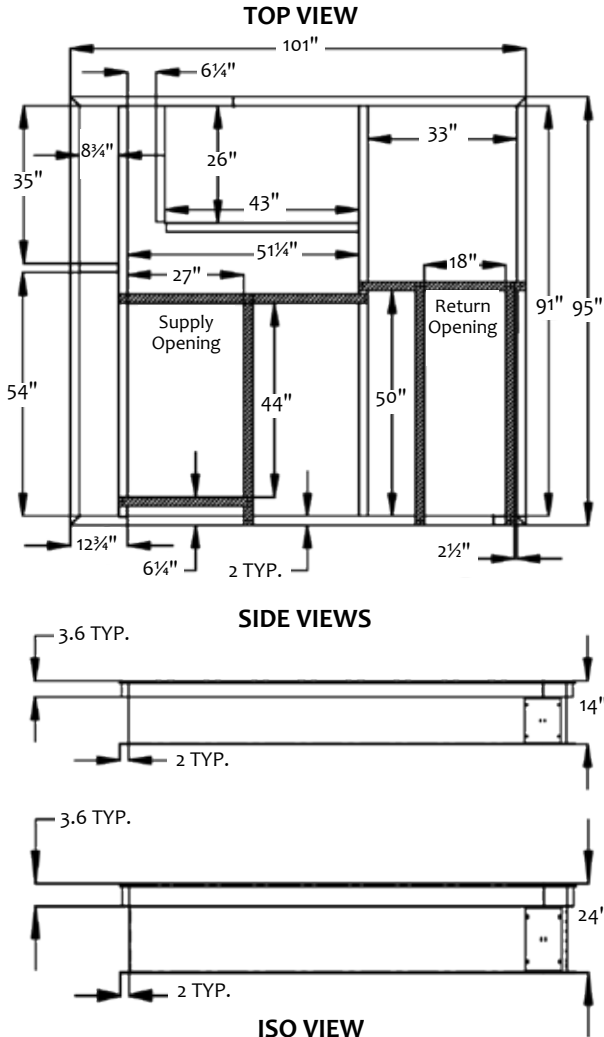
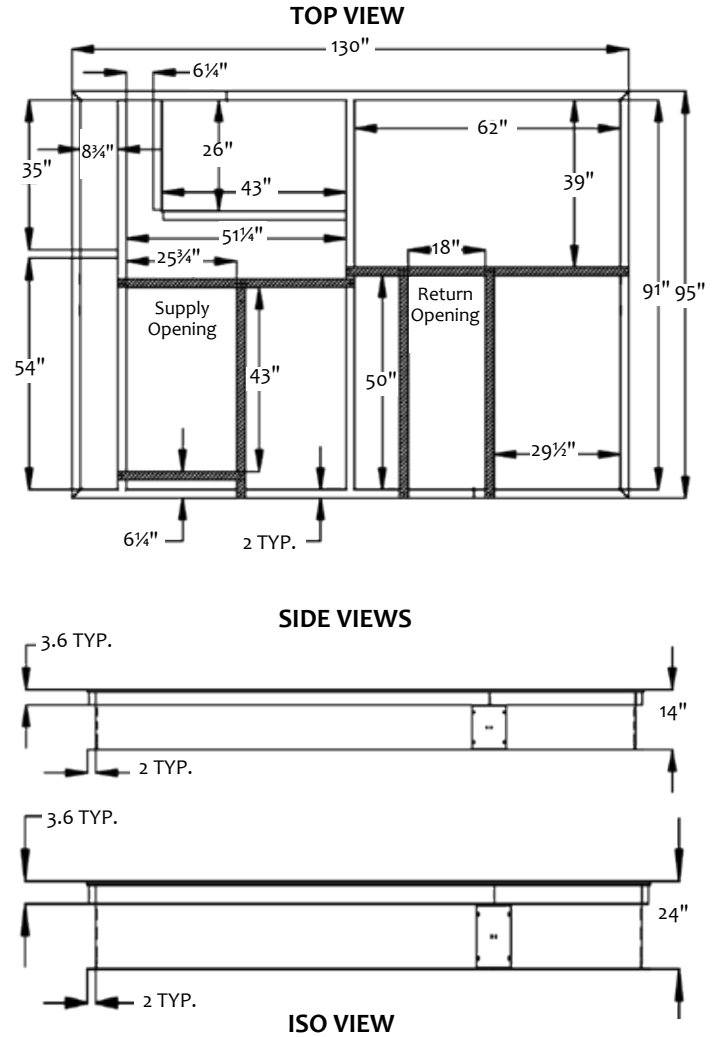

Figure 22 - Roof Curb Assembly – 2 Series, Air Cooled & Water Cooled with ECW Wheel - 14" and 24"



Notes:

1. Knockdown type roof curb, open bottom.
2. Duct support rails are provided with all curbs shown in drawings as thick solid lines.
3. Curb to unit connection should be insulated and sealed.
4. Curb weights— Standard cabinet 14" is 160 lbs and 24" is 250 lbs. ECW wheel cabinet 14" is 200 lbs and 24" is 300 lbs.

Unit Installation

Figure 23 - Roof Curb Assembly – 4 Series, Air Cooled & Water Cooled Standard Cabinet - 14" and 24"

Figure 24 - Roof Curb Assembly – 4 Series, Air Cooled & Water Cooled with ECW - 14" and 24"

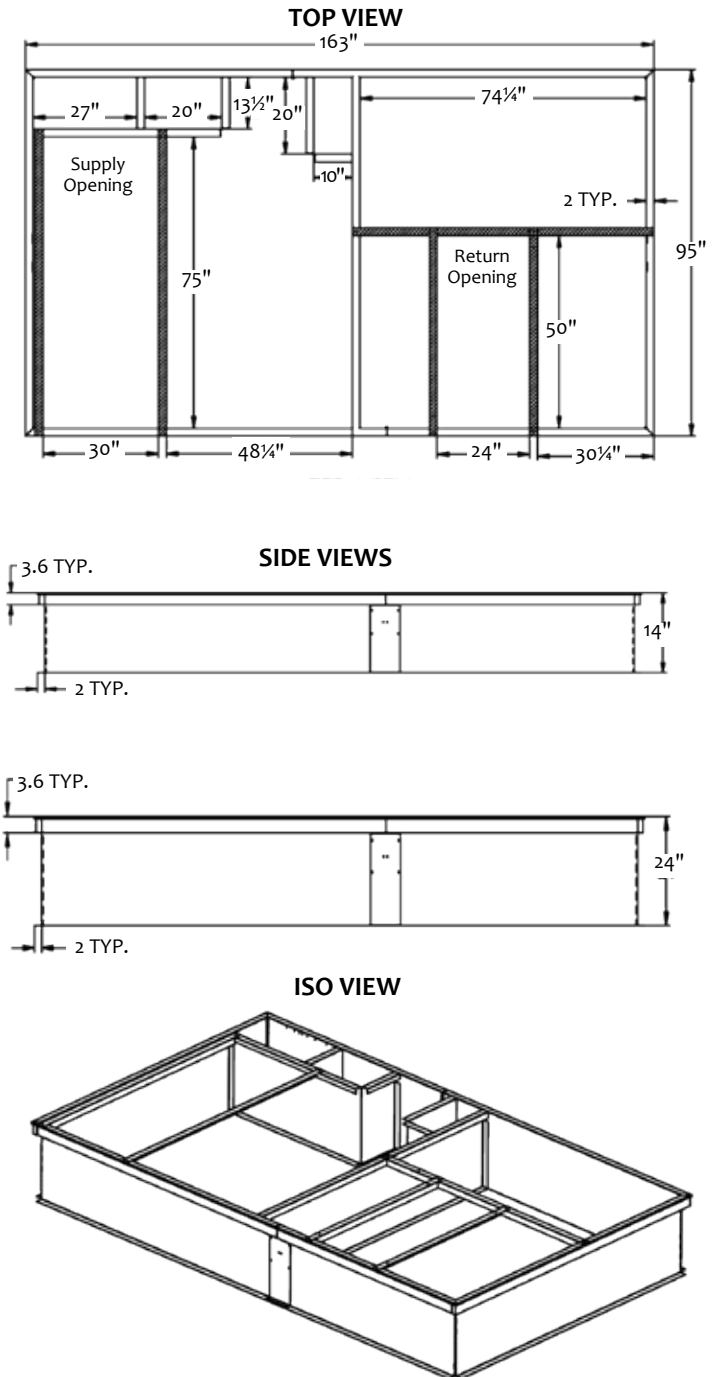
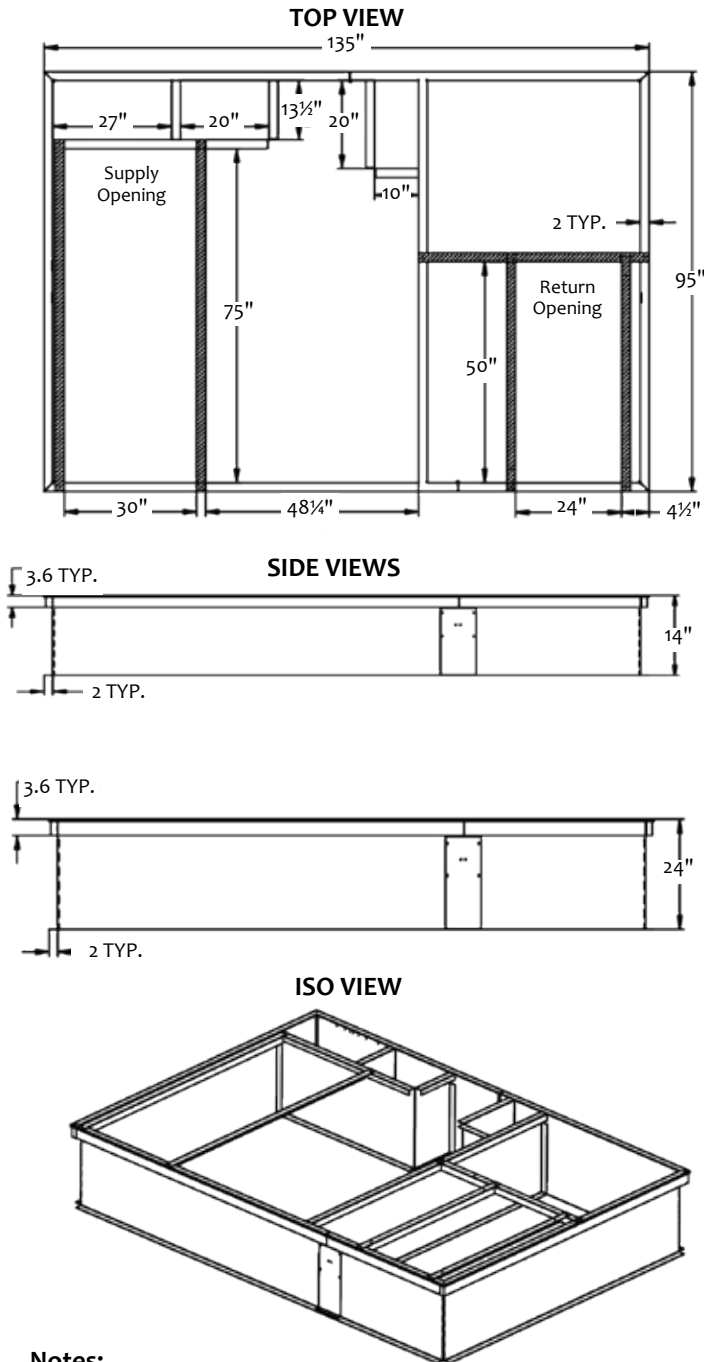

Notes:

1. Knockdown type roof curb, open bottom.
2. Duct support rails are provided with all curbs shown in drawings as thick solid lines.
3. Curb to unit connection should be insulated and sealed.
4. Curb weights— Standard cabinet 14" is 260 lbs and 24" is 350 lbs. ECW wheel cabinet 14" is 300 lbs and 24" is 400 lbs.

Unit Installation

Rigging and Handling

Rigging holes for clevis hangers are provided on the unit base (see Figure 26). Use six (6) independent lines, securing one end of a line to a unit base lifting point and the other end of the line to an associated spreader bar lifting point (see Figure 25). Spreader bars must be used to prevent damage to the unit cabinet. Avoid twisting or uneven lifting of the unit. See Table 1 for rigging cable lengths required.

WARNING/AVERTISSEMENT	
Use all lifting points. Improper lifting can cause property damage, severe personal injury, or death.	Utilisez tous les points de levage. Le levage incorrect peut entraîner des dommages matériels, des blessures graves ou la mort.

Table 1 - Rigging Cable Lengths

Unit	Cabinet base length (in.)	Minimum Cable length (in.)
2 Series w/o wheel	106	93
2 Series with wheel	135	118
4 Series w/o wheel	140	122
4 Series with wheel	168	147

WARNING/AVERTISSEMENT	
Only trained and qualified personnel should be allowed to rig loads or operate load rated cranes and/or hoist assemblies. Do not use a forklift to lift or maneuver the unit. Failure to use load rated crane or hoist assembly to lift or maneuver the unit can cause severe personal injury and property damage.	Seul le personnel formé et qualifié est autorisé à soulever de l'équipement ou manoeuvrer des grues de cargaison et / ou équipements de levage. Ne pas utiliser un chariot élévateur pour soulever ou manoeuvrer l'appareil. Si vous n'utilisez pas a grue ou équipements de levage qualifiée pour soulever ou manoeuvrer l'unité peut causer de graves blessures corporelles et des dégâts matériels.

Figure 25 - Rigging

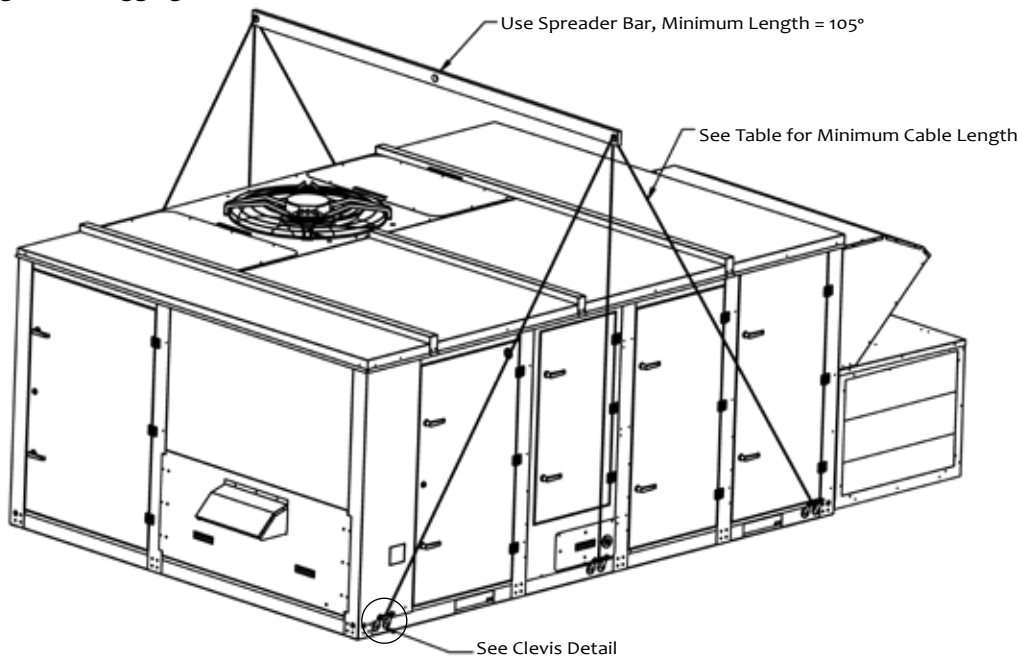
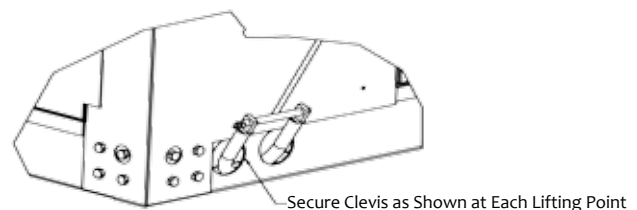

Figure 26 - Clevis Detail



Unit Installation

Unit and Component Weights

Table 2 - Base Unit

Cabinet	Model	Base Unit ¹ (lbs.)				Refrigeration Option (lbs.)	
		AC	ACHP	WSHP	GEHP	HGRH	Sub Cooling
2 Series	06	2042	2092	1872	1872	25	25
	08	2080	2130	1910	1910	25	25
	10	2082	2132	1912	1912	30	30
	13	2097	2147	1927	1927	30	30
	15	2122	2172	1952	1952	30	30
	18	2120	2170	1950	1950	30	30
	20	2126	2176	1956	1956	30	30
4 Series	16	3866	3946	3606	3606	30	30
	21	3870	3950	3610	3610	40	40
	25	3960	4040	3700	3700	40	40
	30	3976	4056	3716	3716	40	40
	35	3982	4062	3722	3722	40	40
	40	4310	4390	4050	4050	40	40

Note: 1. Base unit weight less supply fan and supply fan motor.

Table 3 - Supply Fan Weight

Cabinet	Fan Size	Weight (lbs.)
2 Series	DDP105	46
	DDP150	91
	DDP165	112
	DDP182	131
4 Series	DDP150	91
	DDP165	112
	DDP182	131
	DDP220	196
	DDP245	237
	DDP270	312

Table 4 - Optional Gas Heat

Cabinet	Model	Low		Medium		Medium-High		High	
		Input MBH	Weight (lbs.)	Input MBH	Weight (lbs.)	Input MBH	Weight (lbs.)	Input MBH	Weight (lbs.)
2 Series	06	50	85	100	95	175	141	250	193
	08	50	85	100	95	200	152	300	255
	10	75	85	200	152	300	255	400	291
	13	100	95	200	152	300	255	400	291
	15	100	95	200	152	300	255	400	291
	18	100	95	200	152	300	255	400	291
	20	100	95	200	152	300	255	400	291
4 Series	16	200	165	350	262	400	291	600	454
	21	200	165	400	295	600	454	800	590
	25	200	165	400	295	600	454	800	590
	30	250	195	400	295	600	454	800	590
	35	300	227	400	295	600	454	800	590
	40	300	227	400	295	600	454	800	590

Table 5 - Optional Fan Motor

HP	Weight (lbs.)
1	39
2	66
3	73
5	105
7.5	255
10	276
15	400
20	437
25	509

Table 6 - Optional Power Exhaust Fan Weight

Cabinet	Fan Size	Weight (lbs.)
2 Series	DDP105	246
	DDP150	291
	DDP165	312
	DDP182	331
4 Series	DDP150	401
	DDP165	422
	DDP182	441
	DDP220	506
	DDP245	547
	DDP270	622

Table 7 - Optional Energy Recovery Wheel Weight

Cabinet	Wheel Size	Weight (lbs.)
2 Series	ECW 364	941
	ECW 424	944
	ECW 484	1020
	ECW 486	1070
	ECW 424	1069
4 Series	ECW 484	1145
	ECW 544	1192
	ECW 604	1346
	ECW 664	1670
	ECW 706	1670

Table 8 - Optional Hot Water Coil

Cabinet	Weight (lbs.)
2 Series	60
4 Series	80

Table 9 - Optional Electric Heat

Cabinet	Weight (lbs.)
2 Series	140
4 Series	280

Table 10 - Optional Steam Coil

Cabinet	Weight (lbs.)
2 Series	60
4 Series	80

Unit Installation

Condensate Drain Piping

Units are provided with a 1" male FTP condensate drain connection. Proper drainage is essential and drain connections must be utilized with field installed p-traps. Figure 27 shows the layout of the condensate drain connection. The distance from the bottom of the trap to the horizontal run of the p-trap should be greater than the negative static pressure in the drain pan section.

All units are furnished with slide out, double sloped insulated 304 stainless steel drain pans. Slide out feature provides ease of periodic cleaning to prevent microbial growth and algae buildup from plugging the drain and causing the drain pan to overflow. To make use of the slide out feature, it is suggested to install a union coupling as shown in Figure 27.

Figure 27 - Condensate Drain Trapping

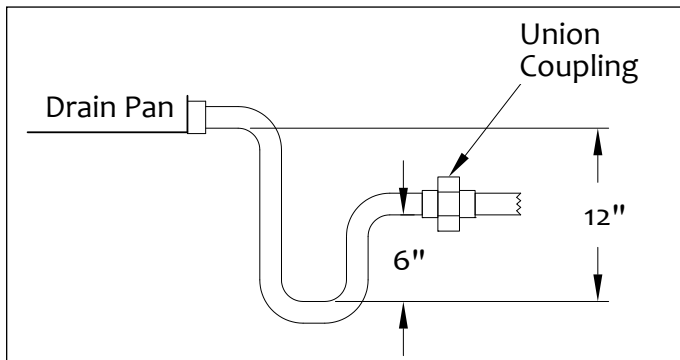

Figure 28 - Slide out, 2 Series Drain Pan



Refer to local codes regarding drainage of condensate directly onto the roof. This may be acceptable in certain areas. A small drip pad must be provided to protect the roof against possible damage.

If condensate is piped into the building drainage system, the drain line must penetrate the roof external to the unit. Pitch the drain line away from the unit a minimum of 1/8" per foot. To provide proper condensate flow, venting is required after the p-trap for sealed drain lines. Please refer to local codes for additional requirements.

Damper Assemblies

Outside Air Dampers

Units come standard with high performance, two-positioned motorized outside and return air dampers with factory installed and preset actuators.

Economizer Dampers

As the actuators modulate, the outside air dampers open, the return air dampers close, and the exhaust air exits the unit through the gravity relief dampers (see Figure 29). All economizer dampers come with factory installed and preset actuators.

Economizer Control Strategy

Standard is outdoor enthalpy. Supply and exhaust air bypass dampers are optional. **Note: When equipped with energy recovery wheel, optional supply and exhaust air bypass dampers may be provided for economizer operation.**

Figure 29 - Economizer Assembly



Discharge Air Temperature Sensor

The discharge air temperature sensor must be installed downstream of the unit, but not downstream of VAV boxes or other dampers, and located in the discharge air duct. The sensor must be in a location that is similar to the average duct temperature and not in the line-of-sight of a gas furnace or electric heater. To allow for air mixing, locate sensor in the center of a duct wall, 5'-10' from unit opening. **Installation:** Drill a hole in duct, insert sensor probe and secure plate to duct with screws. To create an air-tight seal, gasket or silicone sealant must be applied to the back of the mounting plate prior to screwing the plate to the duct.

Unit Installation

Supply Blower Assembly

AMCA certified direct drive blower motor and plenum supply fan assembly with factory installed spring isolators eliminate resonance conditions within operating range. Factory provided integrated variable frequency drive offers flexible operating points in response to changes in pressure, flow or other external conditions. The assembly has a built in piezometer ring (see Figure 30) to measure differential pressure across inlet cone in order to determine airflow through the fan.

Figure 30 - Supply Blower Assembly

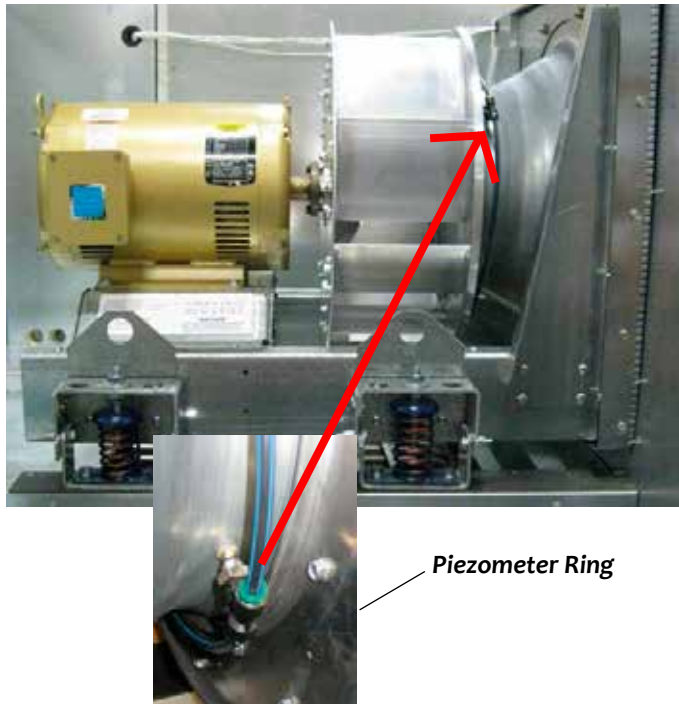

Air Cooled

Condenser Fans

Highly efficient, variable speed EC condenser fans with integral head pressure control are provided as standard. Fans include electronically switched external rotor motors with permanent magnets and the speed of which is controlled by an integrated controller (see Figure 31). Fan speed is controlled by a 0-10 VDC signal.

The integrated variable speed drives are equipped with a solid state motor overload protection and a solid state short circuit protection. The solid state motor overload protection protects the motor under overload conditions by reducing current flow to the internal motor output terminals. The overload protection circuitry is optimally configured to the specific motor and the specific final application of the integrated variable speed drive.

The device is designed with a minimum service life of 40,000 h when operated at full power in the maximum permissible ambient-temperature environment. In order to achieve this, the device protects itself by active temperature management. If a fan is stationary for long periods in a humid atmosphere, it should be switched ON for minimum of two hours every month to remove any moisture that may have condensed within the motor.

Figure 31 - Variable Speed EC Condenser Fan



Air Cooled Coils

Air Cooled coils are provided with aluminum fins mechanically bonded to copper tubes with integral subcooling circuits.

Evaporator Coils

Evaporator coils are provided with aluminum fins mechanically bonded to copper tubes and galvanized steel end casings.

Water Source

Water Piping

As with any water system, it is important that the system be clean. The pipe work installer must remove weld scale, rust and contamination during pipe work fabrication. The system water piping must be flushed thoroughly with recommended alkaline flush or other chemicals that are compatible with 316 stainless steel prior to making connections to the Water Source unit. All water piping must be installed in accordance with applicable codes and standards.

Brazed Plate Heat Exchanger

Water Source units are provided with dual circuited, brazed plate heat exchangers constructed of 316 stainless steel. Units are designed, tested and UL stamped in accordance with ASME Section VIII pressure vessel code for 650 psig working refrigerant pressure. Waterside flush connections with ball valves are provided to allow backwashing and cleaning. See Figure 32 on page 26.

Unit Installation

Figure 32- Brazed Plate Heat Exchanger



Water Source Strainer

To increase efficiency and ensure long life of the equipment, integral strainers (see Figure 33) of cast iron 200psi with 60 mesh removable and cleanable basket filters are provided on each waterside circuit. See Water Treatment section below for additional information.

Figure 33 - Water Source Strainer



The ClimaCool warranty does not cover and does not apply to products which have defects or damages due to freezing of the water supply, corrosives or abrasives in the water supply, or improper or inadequate filtration or treatment of the water supply.

Glycol solution must be used if ambient or loop temperatures fall below 40°F.

Water Treatment

Water quality is of the utmost importance for the proper care and maintenance of a brazed plate heat exchanger. Proper water treatment is a specialized industry and it is recommended to consult an expert in this field to analyze the water for compliance with the water quality parameters listed in Table 11. The material exposed to the water is type 316 stainless steel, pure copper and carbon steel. Other materials may exist external to the ClimaCool unit. It is the user's responsibility to ensure these materials are compatible with the treated water. Regular treatment of the water will increase longevity of your system. **Failure to provide adequate filtration or treatment of the source water will void the warranty.**

Heavy-Contaminated Water

In such instances whereby the particulates in the water are excessive, it is recommended to install an intermediate plate and frame heat exchanger to isolate the ClimaCool unit from the building water system.

Cooling Tower

The cooling tower should be located away from sources of external contaminants such as trees, dust or grass cuttings. Insect infiltration can be reduced by eliminating lights near the tower. A periodic visual inspection of the tower system should be made and contaminants removed as required.

Table 11 - Water Quality Parameters

WATER CONTAINING	CONCENTRATION
Ammonia	Less than 2.0 mg/l
CaCO ₃ Alkalinity	30 - 500 mg/l
CaCO ₃ Hardness	30 - 500 mg/l
Chlorides	Less than 200 mg/l
Dissolved Solids	Less than 1000 mg/l
Iron	Less than 5.0 mg/l
Manganese	Less than 0.4 mg/l
Nitrate	Less than 100 mg/l
pH	7.0 - 9.0
Sulphate	Less Than 200 mg/l

CAUTION/ATTENTION	
Excessive Chlorine, undissolved solids and other improper water conditions WILL DAMAGE the internal heat exchanger & WILL VOID YOUR WARRANTY!	Chlore excessive, solides non dissous et les autres impropres conditions de l'eau, ENDOMMAGERA l'échangeur de chaleur interne et ANNULERA VOTRE GARANTIE!

Unit Installation

Glycol Performance Adjustment Factors Charts

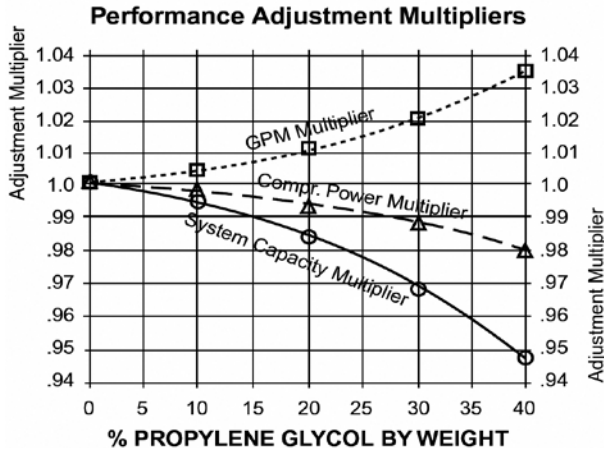

Note: Correction factors shown above are to be applied to Std. Product Data @ ARI 550/590 44°F. Leaving Chilled Water / 85°F Entering / 95°F Leaving Conditioned Water.

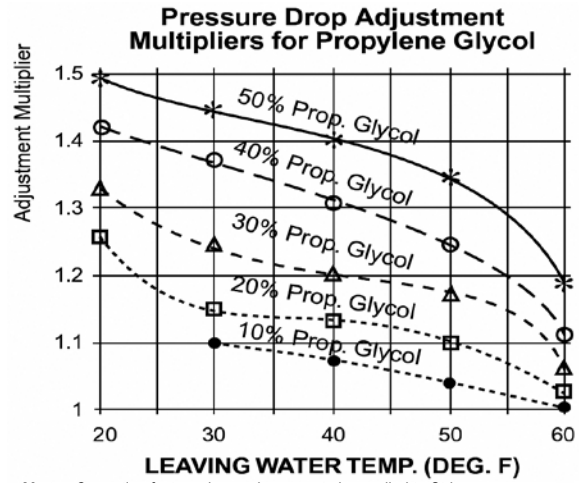

Note: Correction factors shown above are to be applied to Std. Product Data chiller pressure drop curves for straight water.

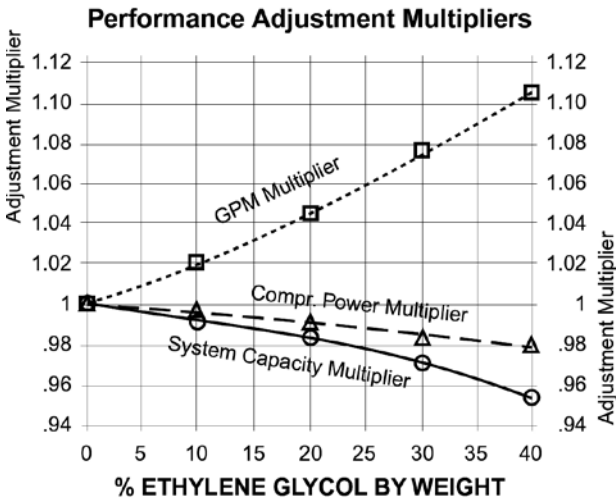

Note: Correction factors shown above are to be applied to Std. Product Data @ ARI 550/590 44°F. Leaving Chilled Water / 85°F Entering / 95°F Leaving Conditioned Water.

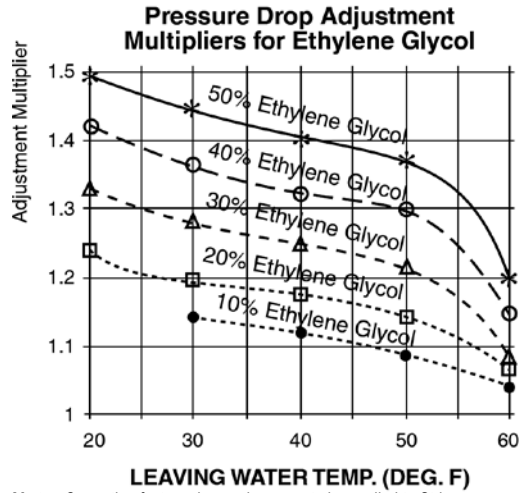

Note: Correction factors shown above are to be applied to Std. Product Data chiller pressure drop curves for straight water.

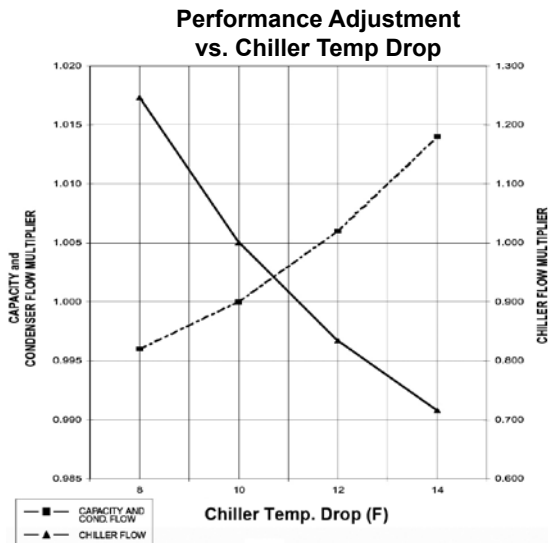
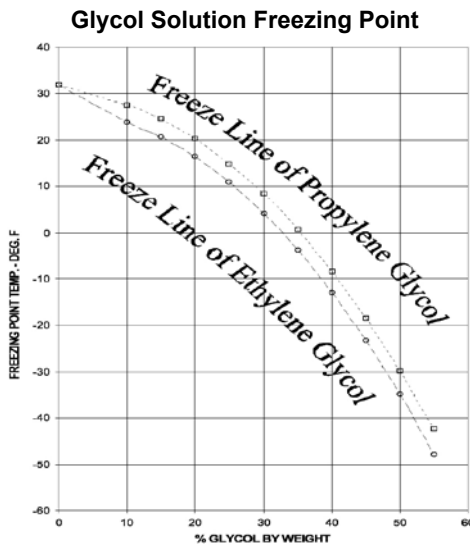

Electrical Connection

The unit nameplate is located on both the outside and the inside of the main control panel door and includes the unit model number, serial number and electrical data. Verification must be made that the unit voltage agrees with power supply prior to initiating any wiring. **All wiring must comply with all applicable local codes and ordinances. If wiring is not in accordance with these specifications, the warranty will be voided.** Refer to unit nameplate and selection software for all pertinent electrical data required. A disconnecting means shall be located within sight of and easily accessible from the air conditioning equipment. A factory mounted, non-fused disconnect switch is available as an option. Suitable overcurrent protection is required. The maximum overcurrent protection device (MOPD) value appears on the unit nameplate. All units are provided with internal power wiring for single point power connection. The power block is located within the main control panel. Field power leads are brought into the unit through knockouts in the bottom of the main control panel.

Size the supply conductors based on the unit minimum circuit ampacity (MCA) shown on the unit nameplate. Refer to Table 12 for the recommended number of power wires.

Table 12 - Recommended Field Power Wiring

Ampacity (MCA)	Number of Power Wires Per Chase	Wire Gauge	Insulation Temperature Rating (°C)
20	1	14	75
25	1	12	75
35	1	10	75
50	1	8	75
65	1	6	75
85	1	4	75
100	1	3	75
115	1	2	75
130	1	1	75
150	1	1/0	75
175	1	2/0	75
200	1	3/0	75
230	1	4/0	75
255	1	250	75

Notes:

1. All wire sizes assume separate conduit for each set of parallel conductors.
2. All wire sizes are based on NEC Table 310-16 for 75° THW wire (copper). Canadian electrical code wire ampacities may vary.
3. All wire sizes assume no voltage drop for short power leads.

Copper wire is required for all conductors. Size wires must be in accordance with the National Electrical Code (N.E.C.) ampacity tables. If long wires are required, it may be necessary to increase the wire size to prevent excessive voltage drop. Wires should be sized for a maximum of 3% voltage drop. Supply voltage must not vary by more than 10% of nameplate. Phase voltage imbalance must not

exceed 2%. Contact the local utility company for correction of improper voltage or phase imbalance. A ground lug is provided in the control panel. Size the grounding conductor in accordance with the N.E.C. Optional factory installed convenience outlets are available with internal or external 115v power supply.

Field Control Wiring

Rooftop units supplied with ClimaCool factory furnished controls may be provided with the following field installed accessories:

- Space temperature override sensor
- BACview user interface
- Remote alarm output
- Discharge air temperature sensor
- Start/Stop - occupied switch

All the above field installed items will be shipped inside the unit damper section.

Phase and Voltage Monitor

Unit is provided with phase and brown-out protection to shut down all motors in the unit if the phases are more than 10% out of balance on voltage, or the voltage is more than 10% under design voltage or on phase reversal.

⚠ WARNING/AVERTISSEMENT	
To avoid possible injury or death due to electrical shock, open the power supply disconnect switch and secure it in an open position during installation.	Pour éviter les blessures ou la mort par électrocution, ouvrir l'interrupteur de sécurité et fixez-le en position ouverte lors de l'installation.

⚠ WARNING/AVERTISSEMENT	
Disconnect power supply (ies) before servicing. Refer servicing to qualified service personnel. Electric shock hazard. May result in injury or death!	
Débrancher avant d'entreprendre le dépannage de l'appareil. Consulter un réparateur qualifié pour le dépannage. Risque de choc électrique. Résultat de mai dans dommages ou la mort!	

⚠ CAUTION/ATTENTION	
Unit to be serviced by qualified personnel only. Refrigerant system under pressure. Relieve pressure before using torch. Recover refrigerant and store or dispose of properly.	
Conifer la maintenance à un technicien qualifié. Le système frigorifique sous pression. Décompresser avant d'exposer à la flamme. Récupérer le frigorigène et le stocker ou le détruire correctement.	

Pre Startup Checklist (Packaged Rooftop Unit)

E-mail technicalsupport@climacoolcorp.com • Fax 405.815.3052

Project Name: _____	Date: _____
Address/Phone: _____	

	YES	NO
1. Are all of the package units connected properly per Codes and the ClimaCool Installation Manual? (Installation, Operation & Maintenance (IOM) Manual is available at www.climacoolcorp.com)	<input type="checkbox"/>	<input type="checkbox"/>
2. Are all of the units level within tolerances for proper condensate drainage?	<input type="checkbox"/>	<input type="checkbox"/>
3. Do all the package units' nameplate voltage agree with the site voltage being supplied?	<input type="checkbox"/>	<input type="checkbox"/>
4. Have all shipping brackets and packing materials been removed from all the units?	<input type="checkbox"/>	<input type="checkbox"/>
5. Are ductwork, electrical, condensate drain, air hoods, and gas service all connected?	<input type="checkbox"/>	<input type="checkbox"/>
6. Has all gas piping been inspected for leaks?	<input type="checkbox"/>	<input type="checkbox"/>
7. Are proper service clearances present per the ClimaCool IOM?	<input type="checkbox"/>	<input type="checkbox"/>
8. Is inlet gas pressure between 4" and 14" WC on all units?	<input type="checkbox"/>	<input type="checkbox"/>
9. Is condenser water system filled and <u>flushed</u> ? (See "Filling the Water System" in ClimaCool IOM.) (If Applicable- water units only)	<input type="checkbox"/>	<input type="checkbox"/>
10. Is chilled water system filled, flushed and all air purged from system? (If Applicable- water units only) (Air must be purged from system prior to startup. See "Filling the Water System" in ClimaCool IOM.)	<input type="checkbox"/>	<input type="checkbox"/>
11. Are all pumps tested and operational? (If Applicable- water units only)	<input type="checkbox"/>	<input type="checkbox"/>
12. Is required GPM (verified by pressure differential) supplied to the chilled water heat exchangers? (If Applicable- water units only) (See project specifications or selection and performance sheets available from ClimaCool Sales Rep.)	<input type="checkbox"/>	<input type="checkbox"/>
13. Is required GPM/Pressure differential being supplied to the condenser water heat exchangers? (If Applicable- water units only) (See project specifications or selection and performance sheets available from ClimaCool Sales Rep.)	<input type="checkbox"/>	<input type="checkbox"/>
14. Is water presently circulating through heat exchangers? (If Applicable- water units only)	<input type="checkbox"/>	<input type="checkbox"/>
15. Verified that factory supplied/field installed temperature sensors have been installed?	<input type="checkbox"/>	<input type="checkbox"/>
16. Is power and communication wiring complete to each package unit?	<input type="checkbox"/>	<input type="checkbox"/>
17. Verified that wiring and devices meet with approved electrical submittal drawings?	<input type="checkbox"/>	<input type="checkbox"/>
18. Is required load available to run multiple compressors at startup?	<input type="checkbox"/>	<input type="checkbox"/>
19. Have crankcase heaters been on for 24 hours before startup?	<input type="checkbox"/>	<input type="checkbox"/>
20. Are all refrigerant service-ball valves on each unit open?	<input type="checkbox"/>	<input type="checkbox"/>
21. Have fan wheels and propellers been checked for location in housing/orifice and set screws tightened?	<input type="checkbox"/>	<input type="checkbox"/>
22. Is control functional to maintain condenser water temperature? (If Applicable- water units only) (Includes maintaining "minimum" inlet temperature; see "Operational Limitations" in ClimaCool IOM.)	<input type="checkbox"/>	<input type="checkbox"/>

If you checked "No" to any question above, provide the line reference number and the date of scheduled completion below. Please note **all conditions must be complete prior to the startup date.**

This form must be completed and submitted to ClimaCool a minimum of **three (3) weeks prior to final scheduling of any startup.*

NOTE: If any of the above items are not complete at time of startup, back charges will be assessed for additional costs.

Contractor Name: _____	
Address: _____	(Authorized Signature) _____
Phone: _____	Date: _____

Start-Up

All units are completely run tested at the factory to promote proper operation in the field. Start-up of this equipment must be performed by ClimaCool certified factory trained technicians. Review the equipment and service literature and become familiar with the location and purpose of all components. A representative of the owner or the operator of the equipment should be present during start-up to receive instructions in the operation, care and adjustment of the unit. **Confirm all power is in compliance with all local and national codes.**

The unit ships from the factory with continuous bulb gasket around all access doors providing weather resistant operation. After the unit is set in place, inspect all door gaskets for shipping damage and replace if necessary.

1. Verify that the unit is properly located and level with proper clearance.
2. Verify that the unit is completely and properly installed with duct work connected.
3. Verify that all construction debris is removed, and that the filters are clean.
4. Verify that all electrical work is complete and properly terminated.
5. Verify that all electrical connections in the unit control panel are tight, and that the proper voltage is connected.
6. Verify all nameplate electrical data is compatible with the power supply.
7. For Air Cooled Units, manually rotate all fans and verify that they rotate freely.
8. Verify wiring is properly sized and connected according to the unit wiring diagram.
9. Verify the phase voltage imbalance is no greater than 2%.
10. Verify that the evaporator condensate drain is trapped and that the drain pan is level.
11. Confirm a union is installed in the external drain piping to facilitate drain pan removal for cleaning.
12. If unit is curb mounted, verify that the curb is properly flashed to prevent water leakage.
13. Review the equipment and service literature, the sequences of operation, and the wiring diagrams to become familiar with the functions and purposes of the controls and devices.
14. Determine which optional controls are included with the unit.

Power-Up

1. Close the unit disconnect switch.
2. Power should now be supplied to the control panel.

Supply & Exhaust Blower Assemblies

1. Remove shipping bolt(s) from supply and exhaust fan assemblies prior to startup (See Figure 34 on Page 31).
2. Electrical power must be locked and tagged out.
3. System connections are properly made and tightened.
4. Impeller and fan surfaces are clean and free of debris.
5. Rotate the impeller by hand to verify it has not shifted in transit.
6. Confirm motor is wired for proper supply voltage, properly sized for power, properly grounded and properly insulated.
7. Trial bump – turn on power just long enough to start assembly rotating and check rotation for agreement with rotation arrow.
8. Verify fastener tightness (see Table 13, page 31):
 - a. Bushing set screw torque.
 - b. Bolts on inlet funnel.
 - c. Motor bolt torque.
 - d. Nuts holding housing frame to base and base to ground.
 - e. Bushing fastener torque.
 - f. Ensure piezo ring tubing will not contact the impeller.

Fan Start-Up

1. Verify all duct isolation dampers are open.
2. Place the unit into the “Fan Only” mode through the keypad.
3. The controller should enter the “Startup Initial” operating state. If the fan does not run, check the manual motor protectors or that the circuit breakers have not tripped.
4. Verify the rotation is correct.

Economizer

1. Check whether the outdoor air is suitable for free cooling.
2. At the keypad, set the cooling setpoint low enough so the controller calls for cooling.
3. Place the unit into cooling mode through the keypad menu.
4. Observe the outdoor air dampers:
 - a. If the outdoor enthalpy is low, the control algorithm should start to modulate the dampers open to maintain the discharge air setpoint.
 - b. If the outdoor enthalpy is high, the dampers should maintain their minimum position.

NOTE: It may not be possible to check the economizer operation in both low and high enthalpy states on the same day. If this is the case, repeat this procedure on another day when the opposite outdoor air enthalpy conditions exist.

Start-Up

Figure 34 - Shipping Bolt



Table 13 - Torque Tables

Bushings Fastener Torque			
Bushing Type	Screw Size	Recommended Torque (in-lbs.)	
JA	10-24	60	
SD/SDS	¼-20	108	
SK	¾-18	180	
SF	¾-16	360	

Bushings Set Screw Torque			
Bushing Type	Screw Size	Recommended Torque (in-lbs.)	
SD/SDS	¼-20	60	
SK	¾-18	110	
SF	¾-16	200	

Motor Bolt Torque			
Bushing Type	Bolt Size (Grade 5)	Washers Size (Top and Bottom)	Recommended Torque (ft-lbs)
56-145T	5/16	5/16	18
182-215T	3/8	3/8	31
254U-286TS	1/2	1/2	75
324T-365T	9/16	9/16	107

Figure 35 - Blower Wheel

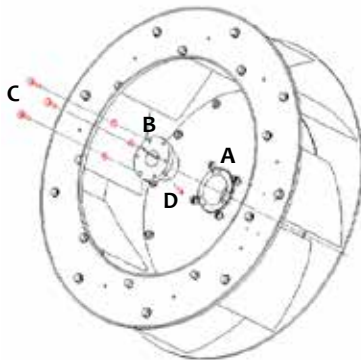

- A - Hub
- B - Bushing
- C - Bushing Screws
- D - Bushing Set Screw

Compressor

With the supply fan operational, prepare for compressor operation.

1. At the keypad, set the cooling setpoint low enough so that the controller will call for cooling.
2. Verify that compressor #1 starts. If the compressor motor hums but does not run, verify that it is wired and phased correctly.
3. The compressor should operate continuously while there is a call for cooling. If the compressor cycles on and off on its low pressure sensor, perform the following:
 - a. Verify that the circuit is not low on refrigerant.
 - b. Check for low airflow across the evaporator coil.
 - c. Check for clogged filters.
 - d. Check for restricted ductwork.
 - e. Check for very low temperature air entering the unit.
 - f. Verify that the liquid line components, expansion valve, and distributor tubes are feeding the evaporator coil.
 - g. Verify that all section panels are closed.
 - h. Verify that the condenser fans are rotating properly (blowing air upward). When the compressor starts, at least one condenser fan should also start.

Adjusting Unit Charge and Expansion Valves Using Subcooling and Superheat Method

Due to varying installation conditions/applications and to optimize performance, proper refrigerant charge and expansion valve adjustment must be confirmed.

After checking compressor rotation, choose a circuit to be tested first. Connect test equipment to monitor the suction line and liquid line temperatures simultaneously. Place a manifold gauge set on the suction line and liquid line then start the compressor. As long as the suction pressure is high enough to prevent the low pressure sensor from tripping, run the compressor for at least five minutes.

Verify proper subcooling. This is accomplished by subtracting the liquid line temperature from the saturated condensing temperature. The saturated condensing temperature is found by converting the liquid line pressure reading on the manifold gauge to the related temperature. The normal subcooling temperature range at the condenser is 5-15°F, BUT for total accuracy, please follow the charge recommendations found in the selection program. If subcooling is too low, then refrigerant must be added to the system. Add charge and wait five minutes before checking results. If subcooling is too high, then refrigerant must be removed from the system.

Start-Up

Verify proper superheat by subtracting the saturated evaporative temperature from the suction line temperature. The saturated evaporative temperature is found by converting the suction pressure reading on the manifold gauge to the related temperature. The proper superheat temperature range is 6-18°F at normal operating conditions. If superheat is low, this may indicate that the expansion valve is overfeeding. To adjust the expansion valves, turn the adjustment stem clockwise. This will cause the superheat to rise. Wait five minutes before checking the results of this adjustment.

Once adjusted, also check the discharge gas superheat to confirm reading is not less than 50°F and the discharge line temperature is not more than 220°F. To check discharge gas superheat, first obtain the saturated condensing temperature by converting the discharge pressure to saturated refrigerant temperature using a pressure

temperature chart. Next, measure the discharge line temperature 6 to 10 inches from the compressor. Subtract the saturated condensing temperature from the discharge line temperature to find the discharge gas superheat. If the DGSH is below 50°F, liquid refrigerant is still present in the suction gas vapor returning to the compressor. The TXV will require additional clockwise adjustment to raise the discharge gas superheat into the acceptable range.

ATTENTION

This manual is specifically intended for qualified installation and service agencies trained to perform the installation and service of the rooftop unit.

Superheat and Subcooling Flow Chart

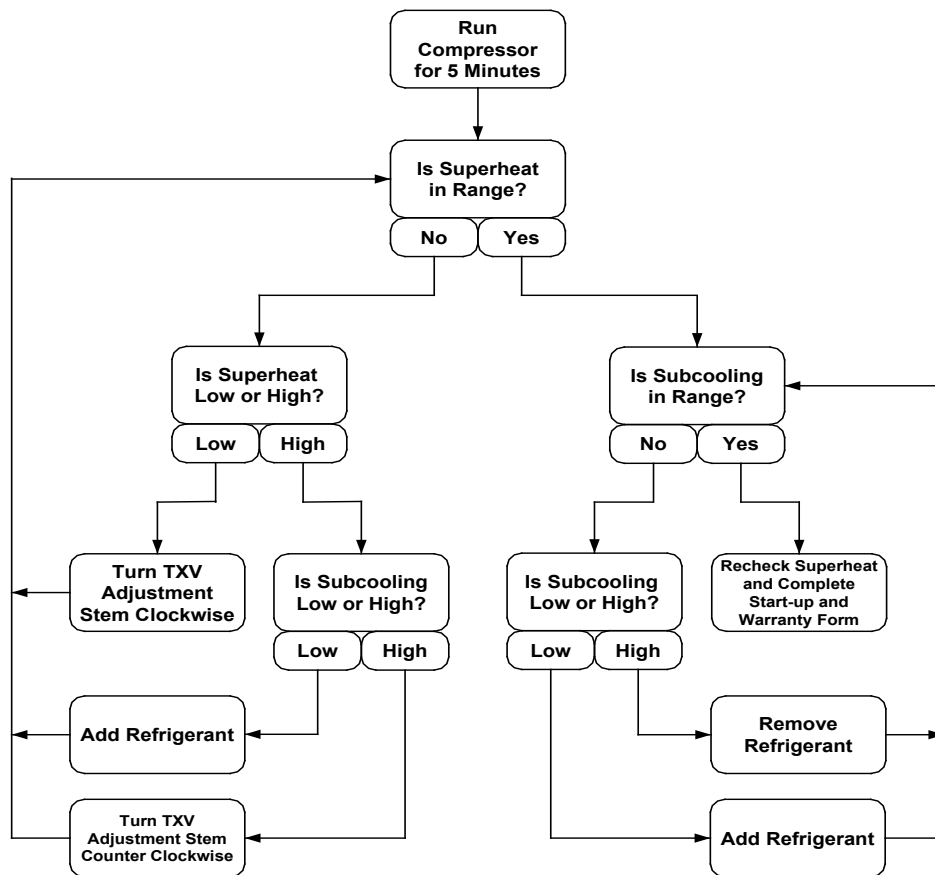

Caution: Do not charge to achieve subcooling temperature when the expansion valve is overfeeding. If the expansion valve is overfeeding, readings may still indicate low subcooling and low superheat, but circuit may not be undercharged.

Start-up

Table 14 - Refrigerant Temperature Pressure Chart

Refrigerant Temperature-Pressure Chart					Refrigerant Temperature-Pressure Chart				
Saturated Conditions – Pressure (psig)					Saturated Conditions – Pressure (psig)				
Temp. °F	R-22	R-134a	R-410A	Temp °C	Temp. °F	R-22	R-134a	R-410A	Temp °C
-40	0.6	14.8"	10.8	-40	60.0	101.6	57.4	170.7	16.0
-38	1.4	13.9"	12.1	-39	62.0	105.4	60.0	176.6	17.0
-36	2.2	12.9"	13.4	-38	64.0	109.3	62.7	182.7	18.0
-34	3.1	12.0"	14.8	-37	66.0	113.2	65.4	188.9	19.0
-32	4.0	10.9"	16.3	-36	68.0	117.3	68.2	195.3	20.0
-30	4.9	9.8"	17.8	-34	70.0	121.4	71.1	201.8	21.0
-28	5.9	8.7"	19.4	-33	72.0	125.7	74.1	208.4	22.0
-26	6.9	7.5"	21.0	-32	74.0	130.0	77.1	215.2	23.0
-24	8.0	6.3"	22.7	-31	76.0	134.5	80.2	222.2	24.0
-22	9.1	5.0"	24.5	-30	78.0	139.0	83.4	229.3	26.0
-20	10.2	3.7"	26.3	-29	80.0	143.6	86.7	236.5	27.0
-18	11.4	2.3"	28.2	-28	82.0	148.4	90.0	244.0	28.0
-16	12.6	0.8"	30.2	-27	84.0	153.2	93.5	251.6	29.0
-14	13.9	0.3	32.2	-26	86.0	158.2	97.0	259.3	30.0
-12	15.2	1.1	34.3	-24	88.0	163.2	100.6	267.3	31.0
-10	16.5	1.9	36.5	-23	90.0	168.4	104.3	275.4	32.0
-8	17.9	2.8	38.7	-22	92.0	173.7	108.1	283.6	33.0
-6	19.4	3.6	41.0	-21	94.0	179.1	112.0	292.1	34.0
-4	20.9	4.6	43.4	-20	96.0	184.6	115.9	300.7	36.0
-2	22.4	5.5	45.9	-19	98.0	190.2	120.0	309.5	37.0
0.0	24.0	6.5	48.4	-18	100.0	195.9	124.2	318.5	38.0
2.0	25.7	7.5	51.1	-17	102.0	201.8	128.4	327.7	39.0
4.0	27.4	8.5	53.8	-16	104.0	207.7	132.7	337.1	40.0
6.0	29.1	9.6	56.6	-14	106.0	213.8	137.2	346.7	41.0
8.0	31.0	10.8	59.5	-13	108.0	220.0	141.7	356.5	42.0
10.0	32.8	11.9	62.4	-12	110.0	226.4	146.4	366.4	43.0
12.0	34.8	13.1	65.5	-11	112.0	232.8	151.1	376.6	44.0
14.0	36.8	14.4	68.6	-10	114.0	239.4	156.0	387.0	46.0
16.0	38.8	15.7	71.9	-9	116.0	246.1	160.9	397.6	47.0
18.0	40.9	17.0	75.2	-8	118.0	253.0	166.0	408.4	48.0
20.0	43.1	18.4	78.7	-7	120.0	260.0	171.2	419.4	49.0
22.0	45.3	19.9	82.2	-6	122.0	267.1	176.5	430.7	50.0
24.0	47.6	21.3	85.8	-4	124.0	274.3	181.8	442.1	51.0
26.0	50.0	22.9	89.6	-3	126.0	281.7	187.4	453.8	52.0
28.0	52.4	24.5	93.4	-2	128.0	289.2	193.0	465.8	53.0
30.0	55.0	26.1	97.4	-1	130.0	296.9	198.7	477.9	54.0
32.0	57.5	27.8	101.4	0.0	132.0	304.7	204.6	490.3	56.0
34.0	60.2	29.5	105.6	1.0	134.0	312.6	210.6	503.0	57.0
36.0	62.9	31.3	109.9	2.0	136.0	320.7	216.7	515.9	58.0
38.0	65.7	33.1	114.3	3.0	138.0	329.0	222.9	529.1	59.0
40.0	68.6	35.0	118.8	4.0	140.0	337.4	229.2	542.5	60.0
42.0	71.5	37.0	123.4	6.0	142.0	345.9	235.7	556.2	61.0
44.0	74.5	39.0	128.2	7.0	144.0	354.6	242.3	570.2	62.0
46.0	77.6	41.1	133.0	8.0	146.0	363.5	249.0	584.5	63.0
48.0	80.8	43.2	138.0	9.0	148.0	372.5	255.9	599.0	64.0
50.0	84.1	45.4	143.2	10.0	150.0	381.7	262.9	613.9	66.0
52.0	87.4	47.7	148.4	11.0					
54.0	90.8	50.0	153.8	12.0					
56.0	94.4	52.4	159.3	13.0					
58.0	98.0	54.9	164.9	14.0					

" - Denotes inches of mercury (" Hg)

Table 15 - Temperature Sensor Chart

Temperature		Resistance (ohms)			
°F	°C	1k Ni	1k Ni ¹	Thermistor	
				2.2k	10k
-50	-46	674	821	109,905	489,981
-40	-40	699	843	75,487	366,185
-30	-34	725	865	52,584	233,990
-20	-29	751	887	37,123	165,085
-10	-23	777	908	26,544	117,978
0	-18	803	930	19,210	85,349
10	-12	830	952	14,063	62,464
20	-7	858	974	10,408	46,221
30	-1	885	996	7,783	34,562
40	4	914	1,017	5,879	26,103
50	10	942	1,039	4,482	19,903
60	16	971	1,061	3,449	15,313
70	21	1,000	1,082	2,676	11,883
80	27	1,030	1,104	2,094	9,298
90	32	1,060	1,125	1,651	7,333
100	38	1,090	1,147	1,312	5,827
110	43	1,121	1,168	1,050	4,663
120	49	1,152	1,190	846	3,757
130	54	1,184	1,211	686	3,048
140	60	1,216	1,232	560	2,488
150	66	1,248	1,254	460	2,043
160	71	1,281	1,275	380	1,687
170	77	1,314	1,296	315	1,401
180	82	1,348	1,317	263	1,170
190	88	1,382	1,339	221	982
200	93	1,417	1,360	186	828
210	99	1,452	1,381	158	701
220	104	1,487	1,402	134	597

1. For 100 ohm platinum sensors, divide resistance values by 10.

Energy Recovery Wheel

Before starting up the unit, check the following:

1. Does the rotor rotate freely by hand? If not, recheck the seal to determine whether or not it is binding and if so adjust seals following the instructions under sealchecks.
2. Is the motor rotation correct? This can be checked by finding the rotational arrows marked on the wheel casing, leaving air side, near the drive motor.
3. Does the air flow orientation match up to design? See the identification markings on the cassette and/or refer to the general arrangement drawing to check the four (4) duct connections to the unit.
4. Are the belts on correctly and sufficiently tight? Belt length is set by the manufacturer. Consult ClimaCool if the belt appears too loose.
5. Is the variable frequency drive (VFD) programmed to control the unit and to prevent frost formation? If not, follow the instructions in the manual accompanying the VFD and/or consult ClimaCool.

Sealchecks

The ECW is provided with a neoprene bulb seal which provides not only an effective seal in both the peripheral and side-to-side sealing directions but also one which is easily adjusted to compensate for seal run-in, shipping misalignment, etc. The neoprene bulb is

attached to a metal reinforced U-shaped neoprene grip. The metal/neoprene grip allows for an expandable grip range which can be moved closer or further from the sealing face as needed. The peripheral bulb seals against the wheel outer band and the inner bulb seals against the wheel face. With the wheel stopped, move seals as close to the sealing surface as possible but without exceeding grip range of bulb seal and without pressing the bulb down against the seal face. Bump the motor. If the motor will not turn, the seal is too close and should be nudged back where needed. The seal will seek its equilibrium position based on the closest part of the sealing face. Because the seal is meant to be a non contact seal, small gaps may be seen between seal and sealing surface once the equilibrium position is reached. Seal leakage is meant to be under 5% at 1 inch of differential between supply and exhaust. Some seal run-in is to be expected, so do not be alarmed by small amounts of wear in the neoprene.

Variable Speed Drive (VFD)

Check the power supply for proper rating. Ensure that the proper jumper orientation is used for the specific control input. Make sure that the unit is programmed for proper input voltage and output voltage restarting immediately following a compressor shutdown. Minimum on is 75 seconds and minimum off is 200 seconds.

Gas Heat

Start-up and service of this equipment must be performed by a ClimaCool certified factory trained technician. A representative of the owner or the operator of the equipment should be present during start-up to receive instructions in the operation, care and adjustment of the unit.

1. Determine where the gas and power can be turned off at the unit and before the unit.
2. Verify installation of gas flue and outside air vents.
3. Verify that gas piping is complete and leak tight.
4. Verify that the shutoff cock is installed ahead of the furnace, and that all air has been bled from the gas lines.

To protect against shipping damage, exhaust hoods are shipped inside the gas section to be installed during installation.

Refer to supplemental Operation, Service and Maintenance manual for startup and maintenance instructions for model HD Series, Gas Furnace.

CAUTION/ATTENTION		WARNING/AVERTISSEMENT	
<p>What to do if you smell gas:</p> <ul style="list-style-type: none"> • Open windows if the appliance is located indoors • Don't touch electrical switches • Extinguish any open flame • Immediately call gas supplier 	<p>Que faire si vous sentez une odeur de gaz:</p> <ul style="list-style-type: none"> • Ouvrez les fenêtres si l'appareil se trouve à l'intérieur • Ne touchez pas aux interrupteurs électriques • Éteignez toute flamme • Appelez immédiatement votre fournisseur de gaz 	<p>Improper installation, adjustment, alteration, service or maintenance can cause injury or death. Read the installation, operating and maintenance instructions thoroughly before installing or servicing this equipment.</p>	<p>Inapproprié installation, un réglage, une modification, un service ou entretien peut causer des blessures ou la mort. Lisez minutieusement les instructions d'installation, d'exploitation et d'entretien avant d'installer ou de réparer ce matériel.</p>

Startup and Warranty Registration Form (Packaged Rooftop)

Sign, date and E-mail to: technicalsupport@climacoolcorp.com or
 Fax: 405.815.3052 Attn: Technical Support

Ambient Temp: _____ Page: 1 of 2

Project Name: _____
 Address: _____
 City/State/Zip: _____
 Startup Date: _____

Contractor Name: _____
 Address: _____
 City/State/Zip: _____
 Phone No.: _____

Package Unit

Model No.: _____
 Serial No.: _____

Compressors

Model No.: _____
 Serial No. 1: _____
 Serial No. 2: _____

Airflow CFM

Supply Air: _____ Exhaust Air: _____

Water Samples Taken: (Mark "X")

Evaporator: Yes Condenser: Yes

For initial MANDATORY water samples, bottles are provided.
 Follow instructions on label and mail the same day sample is taken.

► All wiring terminations in module panel, safeties and compressors tightened: Yes No

Voltage / Ground

	L1	L2	L3
Low Voltage (24V):			
Supply Fan Amps:	L1	L2	L3
ER Wheel Amps	L1	L2	L3

Phase / Phase

L1/L2	L2/L3	L1/L3
208/230 VAC Transformer properly tapped? <input type="checkbox"/>		
EX Fan Amps: L1	L2	L3

Compressor Circuit #1

Amperage:	L1	L2	L3	Cool	Heat
Sight Glass Oil Level:					
Suction Pressure (psig):					
Suction Temperature (F):					
Compressor Superheat (F):					
Discharge Pressure (psig):					
Discharge Temperature (F):		220° Max			
Discharge Gas Superheat (F):		50° Min			
Cond Liquid Line Temperature (F):					
Cond Liquid Subcooling Temp (F):					
Evap Entering Water Temp. (F):					
Evap Leaving Water Temp. (F):					
Cond Entering Air/Water Temp. (F):					
Cond Leaving Air/Water Temp. (F):					
Evap Pressure Differential (psig):					
Cond Pressure Differential (psig):					

Compressor Circuit #2

Amperage:	L1	L2	L3	Cool	Heat
Sight Glass Oil Level:					
Suction Pressure (psig):					
Suction Temperature (F):					
Compressor Superheat (F):					
Discharge Pressure (psig):					
Discharge Temperature (F):		220° Max			
Discharge Gas Superheat (F):		50° Min			
Cond Liquid Line Temperature (F):					
Cond Liquid Subcooling Temp (F):					
Evap Entering Water Temp. (F):					
Evap Leaving Water Temp. (F):					
Cond Entering Air/Water Temp. (F):					
Cond Leaving Air/Water Temp. (F):					
Evap Pressure Differential (psig):					
Cond Pressure Differential (psig):					

► Verify Safety Setting Limits (FN6):

Low Suction Temperature: <input type="checkbox"/>	Low Suction Pressure: <input type="checkbox"/>
---	--

High Discharge Temp: <input type="checkbox"/>	High Discharge Press: <input type="checkbox"/>
---	--

Rep Signature: _____

Print Name: _____

E-Signature: Check Box (Authorized Signature)

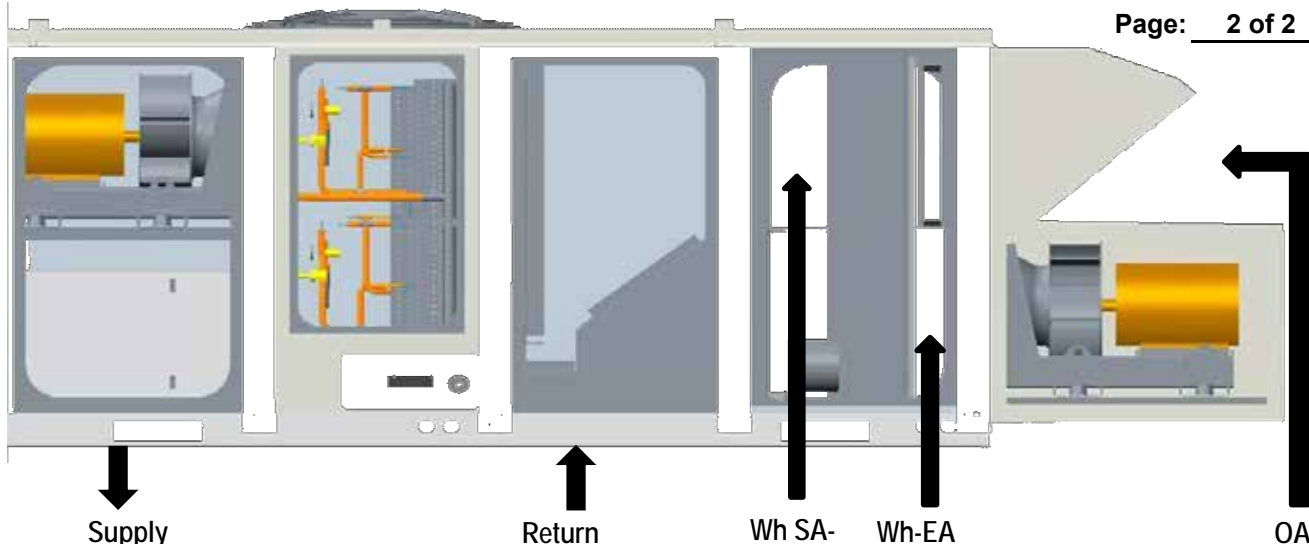

AIR TEMPERATURES

	SUPPLY		RETURN (If Applicable)		WHEEL SA	WHEEL EA	OUTSIDE AIR	
Cooling	DB	*RH	DB	*RH			DB	*RH
*Heating	DB		DB				DB	
*Re-Heat Mode	DB	*RH	DB	*RH			DB	*RH
*AUX Heat Mode (*If Applicable)	DB		DB				DB	

MODULATING HEAT

Gas Furnace

(If Applicable)

Model	<input type="text"/>	Serial	<input type="text"/>
Inlet Gas Pressure	<input type="text"/>	Manifold Press. L/H	
	<input type="text"/>	<input type="text"/>	<input type="text"/>

Air Temperatures

Entering	Leaving
<input type="text"/>	<input type="text"/>

Electric Heater

(If Applicable)

Measured		
Model	Serial	Voltage
<input type="text"/>	<input type="text"/>	<input type="text"/>

Amperage Temp Rise

Stage 1	<input type="text"/>	<input type="text"/>
Stage 2	<input type="text"/>	<input type="text"/>
Stage 3	<input type="text"/>	<input type="text"/>
Stage 4	<input type="text"/>	<input type="text"/>
Stage 5	<input type="text"/>	<input type="text"/>
Stage 6	<input type="text"/>	<input type="text"/>
Stage 7	<input type="text"/>	<input type="text"/>

Startup Technician: _____

Contractor Name: _____

Refrigeration Circuit Diagram

Figure 37 - Packaged Water Cooled - Make Up Air, Straight Cool

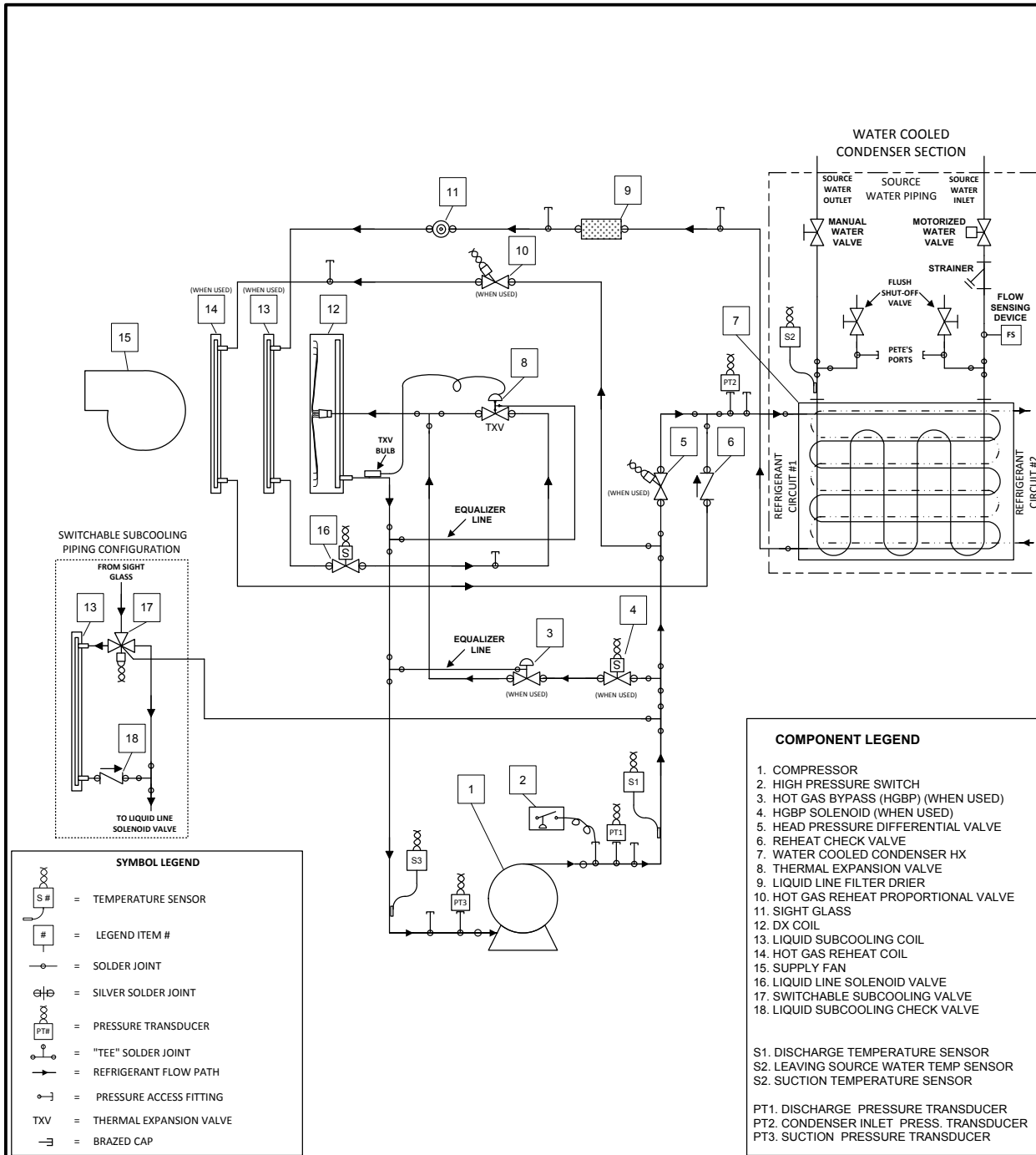

		TITLE REFRIGERATION CIRCUIT DIAGRAM (CIRCUIT #1 OF 2 SHOWN)			
		DESCRIPTION PACKAGE WATER-COOLED MAKEUP AIR (STRAIGHT COOL) CLIMACOOOL Model # RB			
APPROVED	DATE	FILENAME	SCALE	DRAWN BY	DATE
	09/12/2013	RefrigDiag-RA	NONE	Engineering	09/12/2013
REVISED	REVISED	SIZE	DWG NO	REV	
		A	RefrigDiag-RB	B	
			SHEET	1 OF 1	

Refrigeration Circuit Diagram

Figure 38 - Packaged Water Cooled - Make Up Air, Heat Pump

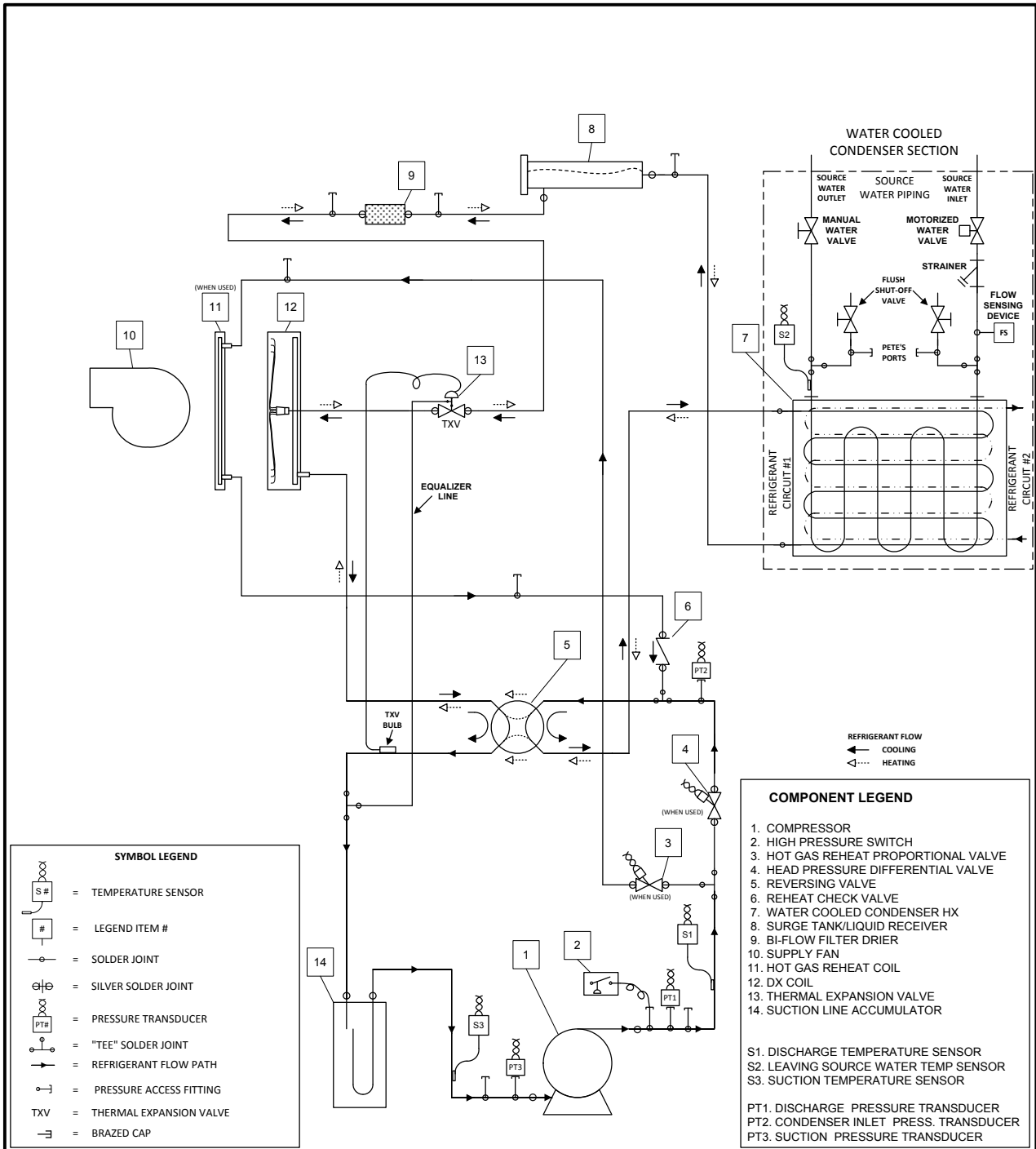

		TITLE		REFRIGERATION CIRCUIT DIAGRAM (CIRCUIT #1 OF 2 SHOWN)	
		DESCRIPTION		PACKAGE WATER SOURCE HEAT PUMP MAKEUP AIR CLIMACOO Model # RW	
APPROVED	DATE	FILENAME	SIZE	ClimaCool Corp. RefrigDiag-RW	DWG NO RefrigDiag-RW
	09/12/2013	RefrigDiag-RW	A		REV A
			SCALE	DRAWN BY	DATE
			NONE	Engineering	09/12/2013
					SHEET
					1 OF 1

Refrigeration System

Piping System

The rooftop unit piping system varies significantly between the multiple possible configurations: heat pump, cooling only, Water Cooled, Air Cooled, hot gas bypass, liquid subcooling and modulating hot gas reheat.

Fixed Speed Compressor

R-410A scroll compressors each having an independent refrigerant circuit are standard on all models. The compressors are provided with internal thermal overload protection and mounted on rubber vibration isolators in an isolated compartment.

Figure 39 - Compressor Cabinet



High Pressure Switch

All units are provided with a manual reset high pressure switch on each refrigerant circuit. When the pressure at the switch exceeds 610 PSIG, the switch will open. This opening will interrupt the control signal to the compressor.

Reversing Valve

The reversing valve is a component only used on heat pumps. This device is used to direct the discharge gas from the compressor into the condenser coil (Heating Mode) or indoor coil (Cooling Mode). This valve is defaulted to cooling and when de-energized will direct the discharge gas into the outdoor coil.

Hot Gas Bypass Valve

The hot gas bypass valve is used to false load the evaporator coil and keep the compressor suction pressure above freezing conditions by introducing a portion of high pressure and high temperature gas to the evaporator/suction side of the system during light loads.

Expansion Valve

Due to varying installation conditions/applications and to optimize performance, proper refrigerant charge and expansion adjustment must be confirmed. Refer to Figure 40.

Figure 40 - Expansion Valve



Suction Pressure Transducer

Suction pressure transducers are supplied on each refrigerant circuit. The transducers screw onto a schrader fitting on the suction line of the compressor deck.

Discharge Pressure Transducer

Discharge pressure transducers are supplied on each refrigerant circuit. The transducers screw onto a schrader fitting on the discharge line of the compressor system. Refer to Figure 41. All pressure transducers have schrader cores factory installed.

Figure 41 - Discharge Pressure Transducer



Discharge Refrigerant Temperature Sensor

Discharge refrigerant temperature sensors are supplied on the discharge line of each compressor. The sensor is attached to the piping with a metal clip.

Refrigeration System

Suction Refrigerant Temperature Sensor

Suction refrigerant temperature sensors are supplied on the suction line of each compressor. The sensor, along with the suction pressure transducer, determines the suction superheat entering the compressor.

Defrost Temperature Sensor

Air source heat pumps will have a defrost temperature sensor which is used in the heating and defrost modes to determine the amount of frost accumulated on the outdoor coil. Refer to Figure 42.

Figure 42 - Defrost Temperature Sensor



Solenoid Valve

The receiver solenoid valve is used to “bleed off” refrigerant vapor from the top of the receiver during pump down or the transition between mechanical heating and defrost. Solenoid valves are only provided with a heat pump application. Refer to Figure 43.

Figure 43 - Solenoid Valve



ATTENTION

To avoid the release of refrigerant into the atmosphere, the refrigerant circuit of this unit must be serviced only by technicians who meet local, state and federal proficiency requirements.

All refrigerant discharged from this unit must be recovered WITHOUT EXCEPTION. Technicians must follow industry accepted guidelines and all local, state and federal statutes for the recovery and disposal of refrigerants.

If a compressor is removed from the unit, system refrigerant circuit oil will remain in the compressor. To avoid leakage of compressor oil, the refrigerant lines of the compressor must be sealed after it is removed.

Compressor Rotation

All scroll-type machines are unidirectional and will only compress in one direction. Operating in the reverse rotation can be destructive and will be indicated by a loud operating noise together with a lack of compression.

Compressor Anti-Short Cycle Timer

Built into the logic of the controller is an anti-short cycle timer which will prevent the compressors from restarting immediately following a compressor shutdown. Minimum on is 75 seconds and minimum off is 200 seconds.

Compressor Lubrication

The compressor operates on a sealed system and oil can only be lost if a leak occurs. There are few cases when oil will need to be added to a machine in normal operation.

Oil Type

The oil in scroll compressors will be either Polyesters type oil (POE) or polyvinyl-ether type oil (PVE). Both refrigerant oils require special handling and should be protected from contamination. They are extremely hygroscopic and will absorb moisture rapidly from the air. It is strongly recommended to store and dispense both oils from sealed metal cans. **Note: Refer to compressor name plate for proper oil type. Different oils cannot be mixed.**

⚠ CAUTION/ATTENTION	
3 PHASE SCROLL COMPRESSOR UNITS	UNITÉ DE COMPRESSEUR SCROLL 3-PHASE
<p>If this unit uses a 3 Phase Scroll Compressor, the following instructions MUST BE followed:</p> <ul style="list-style-type: none"> Unit power supply MUST BE wired in the proper sequence to avoid damage to the 3 Phase Scroll Compressor; Scroll Compressors with INCORRECT rotation show the following characteristics: <ul style="list-style-type: none"> High sound level; High suction pressure and low discharge pressure; Low current draw. If any of the three above characteristics exist, swap two of the three supply wires at the disconnect and recheck compressor for incorrect rotation. 	<p>Si cet appareil utilise compresseur scroll 3-Phase, les instructions suivantes doivent être suivies:</p> <ul style="list-style-type: none"> L'alimentation de l'appareil doit être monté dans l'ordre correct pour éviter endommager le compresseur scroll 3-Phase Compresseurs scroll avec rotation incorrecte montrent les caractéristiques suivantes: <ul style="list-style-type: none"> Haut niveau de son; Pression d'aspiration élevée et une faible pression de décharge; Faible ampérage Si l'un des trois éléments mentionnés ci-dessus sont remplis, échanger deux des trois lignes électriques alimentant l'interrupteur de sécurité et vérifier la rotation du compresseur.

ATTENTION

To avoid the release of refrigerant into the atmosphere, the refrigerant circuit of this unit must be serviced only by technicians who meet local, state and federal proficiency requirements.

All refrigerant discharged from this unit must be recovered WITHOUT EXCEPTION. Technicians must follow industry accepted guidelines and all local, state and federal statutes for the recovery and disposal of refrigerants.

If a compressor is removed from the unit, system refrigerant circuit oil will remain in the compressor. To avoid leakage of compressor oil, the refrigerant lines of the compressor must be sealed after it is removed.

Refrigeration System Re-Processing

Conforming to local and national codes is the responsibility of the service technician or installing contractor. The service technician should be familiar with the following codes:

- ASHRAE Standard Safety Code for Mechanical Refrigeration, ANSI/ASHRAE 15
- American National Standard Code for Pressure Piping, ANSI B31.5

Debris and moisture can enter copper tubing in a matter of minutes. All tubing, coil connections, or any refrigerant containing portions should be temporarily capped or sealed to keep contaminants to a minimum. Filter driers should be opened just prior to brazing into the system to prevent moisture infiltration whenever possible, and flood the system with low pressure dry nitrogen while brazing to prevent oxidation inside the copper piping.

After all of the repairs have been made to the refrigeration system, a pressure test using refrigerant and nitrogen should be performed. Pressurize the system with dry nitrogen to 20 psi and check for any obvious leaks. If no leaks are present, introduce a “trace” amount of refrigerant to the system (raise system pressure to 30-40 psi). With a dry nitrogen tank equipped with a regulator set to 150 psi, continue to pressurize the system to 150 psi. Using a leak detector, carefully check the system for any remaining leaks. If the system is free of leaks, release the pressure.

Evacuating the System

The compressors should never be run while the system is in a vacuum. This could cause immediate failure to the compressors. After the system has been leak tested and sealed, any moisture that entered the system should be dehydrated and removed. While the pressure is reduced under a vacuum, the boiling point of moisture trapped inside the lines is reduced also. A pressure of .0095 psia, or 500 microns absolute pressure or better must be reached and sustained for several hours in order for the system to be considered free from moisture. It is necessary to use a micron meter equipped with an absolute pressure gauge (or transducer) to take this reading. ClimaCool recommends the triple evacuation process to ensure proper removal of moisture and contaminants from the refrigeration system. After the initial vacuum is reached and held on the system, allow dry nitrogen back into the system until the pressure reaches zero psig or slightly higher. Then, repeat the entire evacuation process described above. The evacuation process is considered complete **ONLY** after a successful “blank-off” test is performed.

A “blank-off” test is defined as:

- Pulling a vacuum level less than 500 microns on the system and holding it for several hours.

- Record the vacuum level in the system in microns, then close off the vacuum pump from the system for 15 minutes, and continue to monitor the micron level inside the refrigeration system.
- If the vacuum level inside the system does NOT rise more than 400 microns above the recorded vacuum level at the start of the 15 minute period, then the evacuation process is complete.

If the vacuum level rises more than 400 microns in 15 minutes, then continue to evacuate the system for one to two hours, then repeat a “blank-off” test.

Recharging the System

After all repairs have been completed, the system has been leak tested, and proper vacuum pressures have been reached and maintained, refrigerant may be recharged into the system. With a known weight of refrigerant in the cylinder, use the gauge manifold set to connect the cylinder’s liquid charging port to the charging access port near the refrigerant liquid line valve. Open the compressor suction and discharge line valves if applicable. Gradually meter the appropriate weight of liquid refrigerant into the condenser side of the system first, until no additional refrigerant can be dispensed. Accurate refrigerant charge per circuit may be found on the unit nameplate. Then start the unit and continue the charging process by filling the evaporator side of the system with refrigerant. Close the refrigerant cylinder charging port, close all gauge manifold ports and start the compressor. Be careful when continuing to charge the balance of the refrigerant, constantly maintaining a positive compressor suction pressure (>25 psig) at all times.

⚠ WARNING / AVERTISSEMENT	
	
WATER AND REFRIGERANT SYSTEMS UNDER PRESSURE	EAU ET FRIGORIGÈNE EQUIPEMENTS SOUS PRESSION
<ul style="list-style-type: none">• Isolate/Lockout source and relieve pressure BEFORE servicing equipment• Failure to relieve pressure may result in property damage, serious bodily injury or death!	<ul style="list-style-type: none">• Isoler la source / de verrouillage et de soulager la pression avant entretien de l'équipement• Le défaut de soulager la pression peut entraîner des dommages matériels, des blessures corporelles graves ou la mort!

ATTENTION
To avoid the release of refrigerant into the atmosphere, the refrigerant circuit of this unit must be serviced only by technicians who meet local, state and federal proficiency requirements.
All refrigerant discharged from this unit must be recovered WITHOUT EXCEPTION . Technicians must follow industry accepted guidelines and all local, state and federal statutes for the recovery and disposal of refrigerants.
If a compressor is removed from the unit, system refrigerant circuit oil will remain in the compressor. To avoid leakage of compressor oil, the refrigerant lines of the compressor must be sealed after it is removed.

Factory Installed Options

Energy Recovery Wheel

When a unit is equipped with an optional energy recovery wheel, an exhaust fan is also provided. Energy recovery is provided by drawing outside air across the upper half of the energy recovery wheel and drawing exhaust air across the lower half. Latent heat and sensible heat are transferred from the hotter and moist exhaust to the colder and dry outside air during winter conditions. Latent heat and sensible heat are transferred from the hotter and moist outside air to the cooler and dry exhaust air during summer conditions. The energy recovery wheel cassette is installed on a slide conveyor for ease of cleaning and maintenance (Figure 44).

Energy Recovery Wheel Frost Protection

During extremely cold temperatures, frost formation becomes a possibility in the exhaust air stream. The frost forming on the energy wheel will basically act to plug or reduce air flow however, it will not damage the wheel itself.

ClimaCool offers two means of frost protection:

- Pulsing - defrost cycling using the pressure drop across the wheel as a trigger point, shutting down the wheel, and allowing it to defrost.
- Variable speed control - reducing wheel performance to a level where the exhaust air temperature is kept above the dew point.

Figure 44 - Energy Recovery Wheel

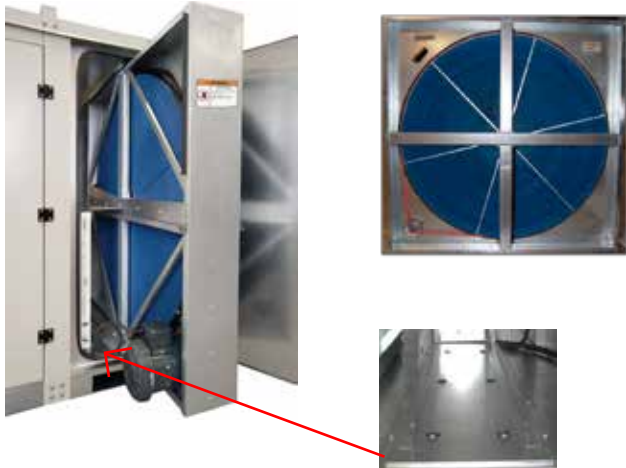

Power Exhaust Assembly

AMCA certified direct drive blower motor and plenum supply fan assembly with factory installed spring isolators eliminate resonance conditions within operating range. Factory provided integrated variable frequency drive offers flexible operating points in response to changes in pressure, flow or other external conditions. The assembly has a built in piezometer ring to measure differential pressure across inlet cone (see Figure 45) in order to determine airflow through the fan.

Figure 45 - Power Exhaust Assembly

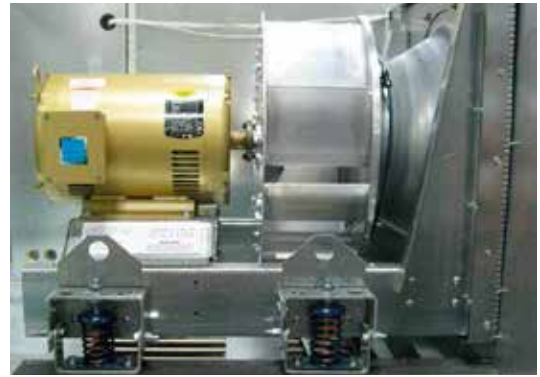

Heating

The unit's heating control is determined by the application. Supplemental heating options provided are: electric heat with modulating control, modulating gas furnace, hot water coil or steam distributing coils.

Electric Heat

The electric heat design consists of heating elements made of nickel/chromium resistance wire, modulating control and all operational safeties. The safety switches include high-limit temperature switches (secondary thermal cutout) and fusing. Refer to Table 16 for available electric heating capacities.

Table 16 - Electric Heating Capacities

Electric Heater Capacity Offerings (kw)			
2 Series			
208V	240V	480V	600V
9	12	12	12
18.75	25	25	25
30	40	40	40
37.5	50	50	50
45	60	60	60
52.5	70	70	70
60	80	100*	100*
4 Series			
208V	240V	480V	600V
30	40	40	40
45	60	60	60
52.5	70	70	70
60	80	80	80
67.5	90	90	90
75	100	100	100
105	140	140	140
119.6	159.5	200	200

*Not available in finned tubular configuration, 80KW max

Factory Installed Options

Gas Furnace

The gas furnace consists of a stainless steel, SS409 or SS304, tubular heat exchanger equipped with a modulating gas valve and adjustable speed combustion blower. The furnace includes an induced draft blower and an electric pressure switch to lockout the gas valve until the combustion chamber is purged and combustion air flow is established. The gas heating assembly is completely factory mounted and is capable of operating at any firing rate between 100% and 20% of rated capacity. Refer to Table 17 for gas heating capacity data.

The furnace incorporates variable speed combustion air blower and electronic modulating controller to provide closed loop control of gas and air to maintain constant thermal efficiency of 80% or higher throughout modulating range. A discharge air sensor is provided for field installation in the supply air ductwork to sense the discharge air temperature. The discharge air set-point shall be adjusted at the electronic controller within the unit control compartment.

Table 17 - Gas Heating Capacity Data

Gas Heat (MBH INPUT)				
UnitID	Low	Medium	Medium - High	High
06	50	100	175	250
08	50	100	200	300
10	75	200	300	400
13	100	200	300	400
15	100	200	300	400
18	100	200	300	400
20	100	200	300	400
16	200	350	400	600
21	200	400	600	800
25	200	400	600	800
30	250	400	600	800
35	300	400	600	800
40	300	400	600	800

Fully Modulating Furnace Controller

All gas furnaces are provided with a furnace controller. This electronic device delivers full control of the modulating furnace. Control includes sequencing, ignition, safety, modulation of the control valve, and the induced draft motor. Input to the furnace control board is a 0-10V signal. The analog signal will modulate the burner down to 20% of full load. Safety inputs include pressure line and electrical connection from the airflow proving switch and electrical connection from the rollout switches. Outputs are to the igniter board, modulating gas valve and to the draft inducing fan motor.

Gas Pressure Requirements

Gas supply pressure to the gas valve inlet must be between 5.0" to 13.5" w.c. for natural gas or 11.0" to 13.5" w.c. for propane gas.

ATTENTION

When pressure testing is at 1/2 psi or less, close the manual shut off valve on the furnace before testing.

When pressure testing gas supply line at 1/2 psi or higher, close manual gas valve and disconnect heater from supply line to be tested. Cap or plug the supply line.

Gas Piping

Gas piping must be sized to provide the minimum required pressure at the burner when the burner is operating at maximum input. Consult your local utility on any questions regarding available gas pressure. The proper size piping must be run from the meter to the gas burner without reductions per standard gas piping practices and per local codes. In the absence of local codes, installation must conform to the current U.S. National Fuel Gas Code or the current Canada National Fuel or Propane Installation Code.

A drip leg and a manual shut-off must be installed in the vertical line before each burner. Install unions so gas train components may be removed for service. After installation, pressurize the piping as required and test all joints for tightness with a rich soap solution. Any bubbling is considered a leak and must be eliminated. **Warning: do not use a match or flame to locate leaks.**

CAUTION/ATTENTION

<p>Gas-fired furnaces are not designed for use in hazardous atmospheres containing flammable vapors or combustible dust in atmospheres containing chlorinated or halogenated hydrocarbons, or in applications with airborne substances containing silicone.</p>	<p>Fours à gaz sont pas conçus pour être utilisés dans des atmosphères dangereuses contenant des vapeurs inflammables ou poussières combustibles, dans des atmosphères contenant des hydrocarbures chlorés ou halogénés, ou dans des applications avec des substances dans l'air contenant de la silicone.</p>
---	--

ATTENTION

This furnace is not listed or suitable for drying or process applications. Use in such applications voids any warranty and manufacturer disclaims any responsibility for the furnace and/or application.

Gas Piping Routing Into Unit

All gas supply piping entrances are located in the unit base for through the curb gas piping and in the outside cabinet wall for across the roof gas piping.

CAUTION/ATTENTION

<p>All field piping must be pressure/leak tested prior to operation. NEVER use an open flame to check for leaks. Use soap solution or other leak detecting solution.</p> <p>Gas pressure to appliance controls must never exceed 13.5" w.c. (1/2 psi).</p>	<p>Toutes les conduites de gaz reliés à l'appareil doivent être inspectés pour des fuites sous pression avant d'utiliser. NE JAMAIS utiliser une flamme nue pour vérifier les fuites. Utilisez une solution de savon ou autre solution de détection des fuites.</p> <p>Contrôles d'appareils à gaz février. Pression ne doit jamais dépasser 13.5" wc (1/2 psi).</p>
--	--

Factory Installed Options

Airflow Proving Switch

The airflow proving switch prevents operation of the gas heater in the event of failure or restriction of the circulating air fan. The airflow probe is installed upstream of the heating section to detect a positive pressure when the circulating air fan is operating during heating cycle. The airflow switch shuts off electrical supply to the ignition controller if a positive pressure is not detected by the switch, due to lack of air flow through the heat exchanger.

Auxiliary Limit

The manual reset auxiliary limit prevents overheating of the heating unit in the event of a circulating air fan failure or reverse air flow. Under these conditions, the integral primary high limit would cycle the furnace resulting in possible heat build-up and damage to the heating unit. The auxiliary limit will function to shut-off the gas supply to the duct furnace.

LP Conversion (Modulating Furnace Only)

Convert the furnace in this unit using the liquefied petroleum (LP) gas valve spring and burner nozzles supplied in the conversion kit. The LP gas valve maintains the proper manifold pressure for LP gas. The correct burner orifices are included in the kit.

Altitude

Gas units are orificed for operation up to 2,000 ft. above sea level unless specified for high altitude operation.

Modulating Hot Gas Reheat

The reheat coil option comes complete with an aluminum fin and copper tube hot gas reheat coil and modulating hot gas valves for leaving air temperature control. On a call for dehumidification, the unit enables the supply air to be cooled (dehumidified) by the evaporator coil. Hot gas from the unit condenser is routed to the hot gas reheat coil downstream of the evaporator coil to reheat the air. Hot gas reheat valves control how much hot gas is routed to the indoor coil to maintain a discharge air set-point. Modulating hot gas reheat is available on all circuits or on lead circuit only.

Liquid Subcooling

Aluminum fin and copper tube liquid subcooling coil is provided to increase total cooling capacity and energy efficiency. The coil is piped in series with the condenser coil. Liquid subcooling is available in constant or switchable configuration.

Hot Water Coil

Aluminum fin and copper tube, two (2) row hot water heating coil.

Steam Coil

Aluminum fin and copper tube, one (1) row steam distributing coil.

Note: Glycol solutions are the only freeze-safe media for operation of water coils at low entering air temperatures. Factory installed piping is copper. Use of dissimilar metal within the plumbing system can cause galvanic corrosion. To avoid corrosion, proper dielectric fittings must be provided as well as appropriate water treatment (see Water Treatment - page 26).

Factory Installed Controls

The unit is equipped with a dedicated stand-alone direct digital control (DDC) system to monitor all unit operations. Computer features are accessed through the LCD display and Building Automation System (BAS) interface can be provided for BACnet communication. The control system provides advanced algorithms for maintaining precise leaving air temperature which must be able to be reset remotely with a 4-20ma input signal.

The unit controller will lead/lag the dual scroll compressors and prevent short cycling. Fault conditions are alarmed so the compressor can be taken off line. Both alarm and failed conditions are displayed on digital display on front of the control panel. An alarm relay for remote indication of faults and failed conditions with a normally open and normally closed dry contact must be supplied. The unit controller has a terminal strip to accept field wired low voltage system interlock such as remote start/stop, common alarm output, etc.

A running history of the complete fault occurrence conditions is automatically maintained (up to the last 100 occurrences) if required for troubleshooting. A RS232 port is provided for use of optional remote Windows® based monitoring and control software via hardwire or telephone modem.

Optional Controls

- Terminal Strip, Controls by Others – Field Installed
- Terminal Strip, Controls by Others – Factory Installed

Factory Installed Options

Compressor Options

Variable speed and digital compressor options are available. For additional information refer to compressor bulletins.

Refrigerant Coil Options

- Condenser and evaporator coils with aluminum fins mechanically bonded to copper tubes with a baked-on phenolic corrosion, E-Coat, resistant coating.
- Evaporator coils with 304 stainless steel end casings.

Filtration

Unit is provided with standard 2" MERV 8, per ANSI/ASHRAE 52.2 test standard, pleated filters. Additional filter options available are:

- 4" MERV 8
- 4" MERV13
- 4"MERV 14
- 2"MERV 8, and 4" MERV 8
- 2"MERV 8, and 4" MERV 13
- 2"MERV 8, and 4" MERV 14

All the above are available with an optional clogged filter indicator.

Maintenance

Performing Service Maintenance

It is highly recommended that all future service be performed by ClimaCool certified trained technicians familiar with local codes and regulations.

Planned Maintenance

Preventive maintenance is the best way to avoid unnecessary expense and inconvenience. Have the system inspected at regular intervals by a qualified service technician. The required frequency of inspections depends upon the total operating time and the indoor and outdoor environmental conditions. Routine maintenance should cover the following items:

- Tighten all wire connections.
- Clean or replace the filters as required.
- Check for blockage of the condensate drain. Clean the condensate pan as needed.
- Check the power and control voltages.
- Check the running amperage of all motors.
- Check all operating temperatures and pressures.
- Check and adjust all temperature and pressure controls as needed.
- Check the operation of all safety controls.
- Check all the fans and tighten their set screws.
- Periodic removal of snow drifts will be required in northern climates.

Coil Cleaning Recommendation

Routine cleaning of coil surfaces is essential to sustaining proper operation and efficiency of the unit. Removal of harmful residues will greatly increase the life of the coils and of the unit as well. A vacuum cleaner or a soft non-metallic bristle brush may be used to remove surface fibers or dirt. Apply the cleaning tool in the direction of the fins. If the tool is applied across the fins, damage can easily occur.

The use of a water stream, such as a garden hose, against the coil will drive fibers and dirt into the coil. This will make cleaning efforts more difficult. Surface loaded fibers must be completely removed prior to using low velocity clean water rinse.

E-Coat Cleaning

A regular maintenance of clean water rinse is recommended for coils that are applied in coastal or industrial environments. It is **very important** that the water rinse is made with a very low velocity water stream to avoid damaging the fin edges.

Servicing Control Panel Components

Disconnect all electric power to the unit when servicing control panel components. Before servicing, always inspect

units for multiple disconnects to ensure all power is removed from the control panel and its components.

Maintenance

Heat Exchanger Backwashing

A buildup of debris or sludge obstructing the free passage of flow through the heat exchangers may occur. This debris can be removed by a back washing process which involves the introduction of a forced, violent backwards flow through the heat exchanger using a carefully formulated flushing solution. To be effective, this back flow should be slightly higher than the normal flow, and in the opposite direction. The difficulties and practicality of this method depend on the back wash pumping system itself. Another method is to back flush each heat exchanger using city water as opposed to system water (see Figure 46). The back washing procedure is accomplished by isolating the individual heat exchanger and introducing the city water using a connection hose to the 3/4" service port to flow in an opposite direction from the normal heat exchanger flow direction. On the opposite 3/4" service port, connect a drain hose to run to a suitable floor drain. Continue the back flow until all debris is removed. **Warning: Water valves must be re-opened after flushing is complete.**

Chemical Clean in Place Washing

Chemical clean in place washing will typically provide the best debris removal, even from severely clogged heat exchangers. The cleaning tank, pump and pump strainer should be arranged in the manner shown in Figure 47 - In Place Cleaning Arrangement. The flow of the cleaning is arranged in the opposite flow to the normal operational direction. Connection points are provided using the 3/4" service ports at each heat exchanger. The cleaning solution used can be either a detergent or hot water to remove particles and simple cleaning. If correct water treatment has been implemented, this should provide adequate cleaning for most situations. The solution can be pumped through the heat exchangers and allowed to soak for a time and then pumped again.

If it is required to remove carbonates, then an acidic wash should be used. A 2% solution of phosphoric or sulfamic acids in pure water are generally acceptable. These acid solutions should only be allowed to circulate within the heat exchanger for 10 to 15 minutes, followed by a thorough pure water flush for 10 to 15 minutes. **Hydrochloric or sulfuric acids must not be used.** In any case, consult the chemical supplier to establish the correct formulation and handling process. The materials exposed to the wash are stated in the Water Treatment section (see page 26).

Once the washing is complete, the solution should be flushed out completely by pumping clean, fresh water through the water circuit. To achieve a reasonable level of dilution, it may be required to change the water several times. After cleaning, the water quality and water treatment should be confirmed.

Cleaning Arrangement

Figure 46 - City Water Cleaning Arrangement

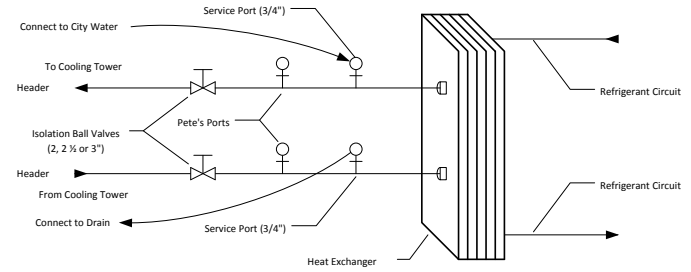
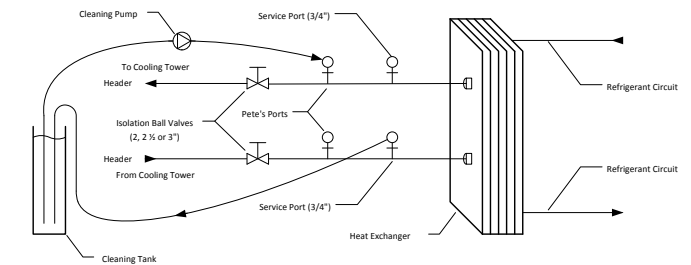

Figure 47 - In Place Cleaning Arrangement



Note:

1. When backwashing, be sure to flush in opposite direction of flow.

Supply & Exhaust Blower Assemblies

Keeping motors and windings clean is important because dirt and dust can cause heat to be trapped causing overheating and/or premature failure. Blow dust and dirt out of windings and off the motor periodically by using low pressure, 50 psi, airstream to prevent winding damage. Keep the areas surrounding the motor clean so the air can circulate through the motor cooling fan.

Check vibrations isolators, bolts and foundations at regular intervals for corrosion. Improper mounting can lead to poor operation characteristics, fan fatigue, and failure.

Energy Recovery Wheel

Small wheels, (smaller than ECW666) are provided with zero maintenance, permanently sealed inboard bearings. Larger wheels come equipped with an external flanged bearing which requires being greased annually with a petroleum based lubricant.

The wheel seals are easily adjustable contact brush seals on both the periphery and face of the wheel. The wheel cassette has a built in adjustable purge section minimizing cross contamination of supply air.

Maintenance

Drive systems shall consist of fractional horsepower AC drive motors with multilink drive belts. Belts are provided with individual links providing quick, easy servicing or replacement.

The wheel is designed to last the life of the equipment. It should be protected by an ASHRAE 30% filter to keep dust and dirt from the heat transfer surface. The wheel is basically self cleaning through its normal action of rotating in and out of countercurrent air flow streams. If the wheel becomes dirty, it may be cleaned by blowing out the unit with compressed air (20 psig maximum). The wheel is installed on a slide out conveyor for ease of cleaning. The ECW contains a mechanical stop that prevents the wheel from sliding out beyond halfway during the cleaning process. If excessive cleaning becomes necessary and the wheel must be removed from the unit, the mechanical stop would need to be disengaged. **Caution must be taken during the removal process as improper handling may result in serious injury.** In cases of severe uncleanliness, the wheel may be removed from the cassette and washed with water following wheel removable procedures outlined below:

1. Remove air handler plenum sections so that the front or back of the cassette may be easily accessed and cleared.
2. Support the wheel from the bottom.
3. If the unit is equipped with an external flanged bearing, loosen the allen screws in the bearing housing that keeps the shaft affixed in the horizontal plane on both bearing, front and back. Remove the shaft clips at the face of the hub from both sides of the shaft. Unbolt one post completely and remove post with bearing completely out. Remove the shaft. Roll the wheel out carefully.
4. If the unit is equipped with an internal bearing, unbolt the shaft screw on both sides of the shaft. Unbolt one post completely and remove post. Remove the shaft clips at the face of the hub from both sides of the shaft. Remove the shaft. Roll the wheel out carefully.
5. With the wheel out, wash the media carefully with water. Once clean, allow the media to dry out for several hours or days if necessary.
6. Reinstall using the reverse procedure. Run the unit. It may take several hours for the desiccant to dry out and for the wheel to perform normally.

No maintenance should be required on the variable frequency controller (VFD). Should problems with the VFD develop, consult the service manual that accompanied the order or call ClimaCool for service information.

ATTENTION
This manual is specifically intended for qualified installation and service agencies trained to perform the installation and service of the rooftop unit.

WARNING/AVERTISSEMENT
Improper installation, adjustment, alteration, service or maintenance can cause injury or death. Read the installation, operating and maintenance instructions thoroughly before installing or servicing this equipment.
Inapproprié installation, un réglage, une modification, un service ou entretien peut causer des blessures ou la mort. Lisez minutieusement les instructions d'installation, d'exploitation et d'entretien avant d'installer ou de réparer ce matériel.

WARNING/AVERTISSEMENT

AVOID INJURY
• Use extreme CAUTION when sliding or removing this object.
• Improper handling may result in property damage or serious bodily injury!
EVITER LES BLESSURES
• Soyez extrêmement prudent lorsque vous faites glisser ou de retirer cet objet.
• Une mauvaise manipulation peut entraîner des dommages matériels ou des blessures corporelles graves!

Gas Furnace

Turn off all electrical power to the unit before inspection and servicing.

1. The duct furnace should be inspected annually by a qualified service agency. The condition of the burners, heat exchanger, draft inducer, vent system, operating controls and wiring should be determined. Check for obvious signs of deterioration, accumulation of dirt and debris and any heat or water related damage. Any damaged or deteriorated parts should be replaced before the unit is put back into service.
2. Clean burners, heat exchanger, induced draft fan and vent ducts.
3. Check heat exchanger for cracks. If any are present, replace heat exchanger before putting unit back into service.
4. Check the attachment point of the duct furnace to the cabinet to verify that they are air tight.
5. Check the automatic gas valve to insure that the gas valve seat is not leaking.
6. Check wiring connections to be sure they are secure and inspect wiring for any deterioration.
7. Label all wires prior to disconnection when servicing unit. Wiring errors can cause improper or dangerous operation. Verify proper operation after servicing.

CAUTION/ATTENTION
What to do if you smell gas:
• Open windows if the appliance is located indoors
• Don't touch electrical switches
• Extinguish any open flame
• Immediately call gas supplier
Que faire si vous sentez une odeur de gaz:
• Ouvrez les fenêtres si l'appareil se trouve à l'intérieur
• Ne touchez pas aux interrupteurs électriques
• Éteindre toute flamme
• Appelez immédiatement votre fournisseur de gaz

WARNING/AVERTISSEMENT
To avoid possible injury or death due to electrical shock, open the power supply disconnect switch and secure it in an open position during installation.
Pour éviter les blessures ou la mort par électrocution, ouvrir la interrupteur de sécurité et fixez-le en position ouverte lors de l'installation.

CAUTION/ATTENTION
Use only copper conductors for field installed wiring. Unit terminals are not designed to accept other types of conductors.
Utilisez uniquement des conducteurs en cuivre pour le câblage. Bornes de l'unité ne sont pas conçus pour accepter d'autres types de conducteurs.

ATTENTION
To avoid the release of refrigerant into the atmosphere, the refrigerant circuit of this unit must be serviced only by technicians who meet local, state and federal proficiency requirements.
All refrigerant discharged from this unit must be recovered WITHOUT EXCEPTION. Technicians must follow industry accepted guidelines and all local, state and federal statutes for the recovery and disposal of refrigerants.
If a compressor is removed from the unit, system refrigerant circuit oil will remain in the compressor. To avoid leakage of compressor oil, the refrigerant lines of the compressor must be sealed after it is removed.



CLIMACOOOL CORPORATION LIMITED EXPRESS WARRANTY/LIMITATION OF REMEDIES AND LIABILITY WITH EXTENDED COMPRESSOR WARRANTY

WARRANTY DISCLAIMER

It is expressly understood that unless a statement is specifically identified as a warranty, statements made by ClimateCool Corp., an Oklahoma corporation ("CC"), or its representatives, relating to CC's products, whether oral, written or contained in any quote, sales literature, catalog or any agreement, are not express warranties and do not form a part of the basis of the bargain, but are merely CC's opinion or commendation of CC's products. **EXCEPT AS SPECIFICALLY SET FORTH HEREIN, THERE IS NO EXPRESS WARRANTY AS TO ANY OF CC'S PRODUCTS. CC MAKES NO WARRANTY AGAINST LATENT DEFECTS. CC MAKES NO WARRANTY OF MERCHANTABILITY OF THE GOODS OR OF THE FITNESS OF THE GOODS FOR ANY PARTICULAR PURPOSE.**

GRANT OF LIMITED EXPRESS WARRANTY

CC warrants CC's products purchased and retained in the United States of America and Canada to be free from defects in material and workmanship under normal use and maintenance only as follows:

FOR MODULAR CHILLERS: (a) All modular chillers built or sold by CC for twelve (12) months from the date of unit start-up or eighteen (18) months from date of shipment (from CC's warehouse), whichever comes first; and (b) Any repair and replacement parts, which are not supplied under warranty, for ninety (90) days from date of shipment (from CC's warehouse) and (c) If such extended warranty is purchased, the compressors in all modular chillers built or sold by CC shall extend for sixty (60) months from the date of shipment (from CC's warehouse).

FOR ROOF TOP UNITS: (a) All roof top units built or sold by CC for twelve (12) months from the date of unit start-up or eighteen (18) months from date of shipment (from CC's warehouse), whichever comes first; (b) All compressors supplied by CC with CC's roof top units for sixty (60) months from date of shipment (from CC's warehouse); (c) All gas fired stainless steel heat exchangers supplied by CC with CC's roof top units for ten (10) years from date of shipment (from CC's warehouse); and (d) Any repair and replacement parts, which are not supplied under warranty, for ninety (90) days from date of shipment (from CC's warehouse).

All parts must be returned to CC's warehouse in Oklahoma City, Oklahoma, freight prepaid, no later than sixty (60) days after the date of the failure of the part. If CC determines the part to be defective and within CC's Limited Express Warranty, CC shall, when such part has been either replaced or repaired, return such to a CC recognized dealer, contractor or service organization, F.O.B. CC's warehouse, Oklahoma City, Oklahoma, freight prepaid. The warranty on any part repaired or replaced under warranty expires at the end of the original warranty period.

This warranty does not cover and does not apply to: (1) Fuses, refrigerant, fluids, oil; (2) Products relocated after initial installation; (3) Any portion or component of the system that is not supplied by CC, regardless of the cause of the failure of such portion or component; (4) Products on which the units identification tags or labels have been removed or defaced; (5) Products on which payment to CC is or has been in default; (6) Products which have defects or damage which result from improper installation, wiring, electrical imbalance characteristics or maintenance (including, without limitation, defects or damages caused by voltage surges, inadequate voltage conditions, phase imbalance, any form of electrical disturbances, inadequate or improper electrical circuit installation or protection, failure to perform common maintenance, etc.); or are caused by accident, misuse or abuse; (7) Products which have defects or damage which result from a contaminated or corrosive air or liquid supply, operation at abnormal temperatures, or unauthorized opening of a refrigerant circuit; (8) Products subjected to corrosion or abrasion or chemicals; (9) Mold, fungus or bacteria damage; (10) Products manufactured or supplied by others; (11) Products which have been subjected to misuse, negligence or accidents; (12) Products which have been operated in a manner contrary to CC's printed instructions; (13) Products which have defects, damage or insufficient performance as a result of insufficient or incorrect system design or the improper application of CC's products; (14) Products which have defects or damages due to freezing of the water supply, an inadequate or interrupted water supply, corrosives or abrasives in the water supply, or improper or inadequate filtration or treatment of the water or air supply; (15) Products which are defects caused by overfilling, use of incorrect fuel, or improper burn or control adjustments; or (16) Products which have incomplete or inadequate combustion.

CC is not responsible for: (1) The costs of any fluids, refrigerant or other system components, or the associated labor to repair or replace the same, which is incurred as a result of a defective part covered by CC's Limited Express Warranty; (2) The costs of labor, refrigerant, materials or service incurred in removal of the defective part, or in obtaining and replacing the new or repaired part; or, (3) Transportation costs of the defective part from the installation site to CC or the return of any part not covered by CC's Limited Express Warranty.

Limitation: This Limited Express Warranty is given in lieu of all other warranties. If, notwithstanding the disclaimers contained herein, it is determined that other warranties exist, any such warranty, including without limitation, any express warranties or any implied warranties of fitness for any particular purpose and merchantability, shall be limited to the duration of the Limited Express Warranty.

LIMITATION OF REMEDIES

In the event of a breach of this Limited Express Warranty, CC will only be obligated at CC's option to repair the failed part or module or to furnish a new or rebuilt part or module in exchange for the failed part or module which has failed. If, after written notice to CC's Head Office in Oklahoma City, Oklahoma of each defect, malfunction or other failure and a reasonable number of attempts by CC to correct the defect, malfunction or other failure and the remedy fails of its essential purpose, CC shall refund the purchase price paid to CC in exchange for the return of the sold good(s). Said refund shall be the maximum liability of CC. **THIS REMEDY IS THE SOLE AND EXCLUSIVE REMEDY AGAINST CC FOR BREACH OF**

CONTRACT, FOR THE BREACH OF ANY WARRANTY OR FOR CC'S OWN NEGLIGENCE OR IN STRICT LIABILITY.

LIMITATION OF LIABILITY

CC shall have no liability for any damages if CC's performance is delayed for any reason or is prevented to any extent by any event such as, but not limited to any, war, civil unrest, government restrictions or restraints, strikes, or work stoppages, fire, flood, accident, allocation, shortages of transportation, fuel, material or labor, acts of God or any other reason beyond the sole control of CC. **CC EXPRESSLY DISCLAIMS AND EXCLUDES ANY LIABILITY FOR CONSEQUENTIAL OR INCIDENTAL DAMAGE IN CONTRACT, FOR BREACH OF ANY EXPRESS OR IMPLIED WARRANTY, OR IN TORT, WHETHER FOR CC'S OWN NEGLIGENCE OR AS STRICT LIABILITY.**

OBTAINING WARRANTY PERFORMANCE

Normally, the contractor or service organization who installed the products will provide warranty performance for the owner. Should the installer be unavailable, contact any CC recognized contractor or service organization. If assistance is required in obtaining warranty performance, write:

ClimateCool Corp. • P.O. Box 2055 • Oklahoma City, Oklahoma 73101 • (405) 815-3000 • e-mail: Claims@climacoolcorp.com

NOTE: Some states or Canadian provinces do not allow limitations on how long an implied warranty lasts, or the limitation or exclusion of consequential or incidental damages, so the foregoing exclusion and limitations may not apply to you. This warranty gives you specific legal rights, and you may also have other rights which vary from state to state and from Canadian province to Canadian province.

Please refer to the CC Installation, Operation and Maintenance Manual for operating and maintenance instructions.

forms\ccool\standard forms\word files\CCool warranty compressor certificate 07-17-14

Contact your local ClimaCool representative or visit our website at www.climacoolcorp.com to find out more about the heating and cooling solutions that may fit your application needs.



15 S. Virginia
Oklahoma City, OK 73106
Phone: 405-815-3000
Fax: 405-815-3052
www.climacoolcorp.com



ClimaCool works continually to improve its products. As a result, the design and specifications of each product at the time for order may be changed without notice and may not be as described herein. Please contact ClimaCool's Customer Service Department at 405-815-3000 for specific information on the current design and specifications. Statements and other information contained herein are not express warranties and do not form the basis of any bargain between the parties, but are merely ClimaCool's opinion or commendation of its products.

'USGBC®' and related logo is a trademark owned by the U.S. Green Building Council® and is used with permission.