

Dehumidifier Consorb **DC-50R**



Dehumidifying capacity at 68°F / 60%RH

6.6 lbs/hr

Dry air flow

320 CFM

- ↘ Highly efficient D-MAX rotor
- ↘ No desiccant carry-over
- ↘ Stainless steel chassis
- ↘ Easy to maintain
- ↘ Long lifetime

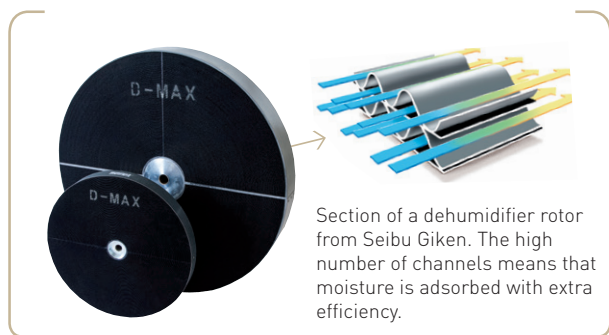

TECHNICAL DATA

Dehumidifier model	DC - 50R
Nominal capacity ¹ (lbs/hr)	6.6
Dry air flow ² (CFM)	320
Static pressure (In w.c)	0.6
Wet air flow ² (CFM)	90
Static pressure (In w.c)	0.4
Heater power (kW)	5.0
Maximum electric consumption (kW)	7.6
Supply fuse 3 x 480V/60 Hz (A)	16
Weight (lbs)	140

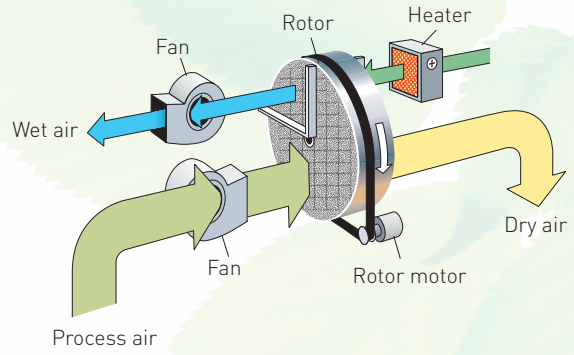

¹ Valid for 68°F/60%RH. For other condition see below table.
² Free blowing at density 0.075 lb/ft³.

DEHUMIDIFICATION CAPACITY

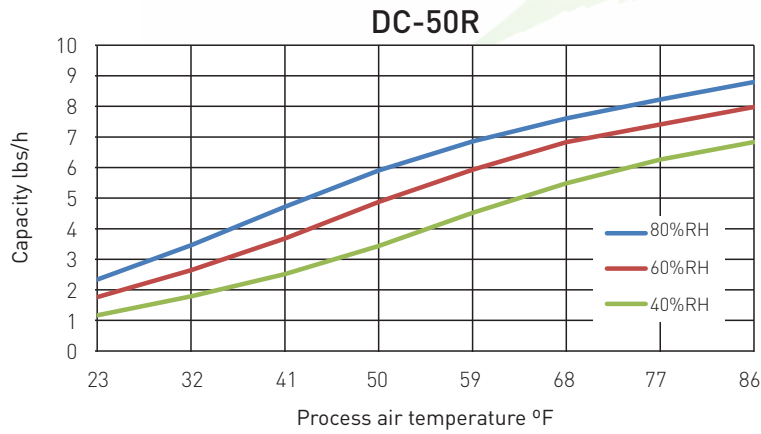

DIMENSIONS

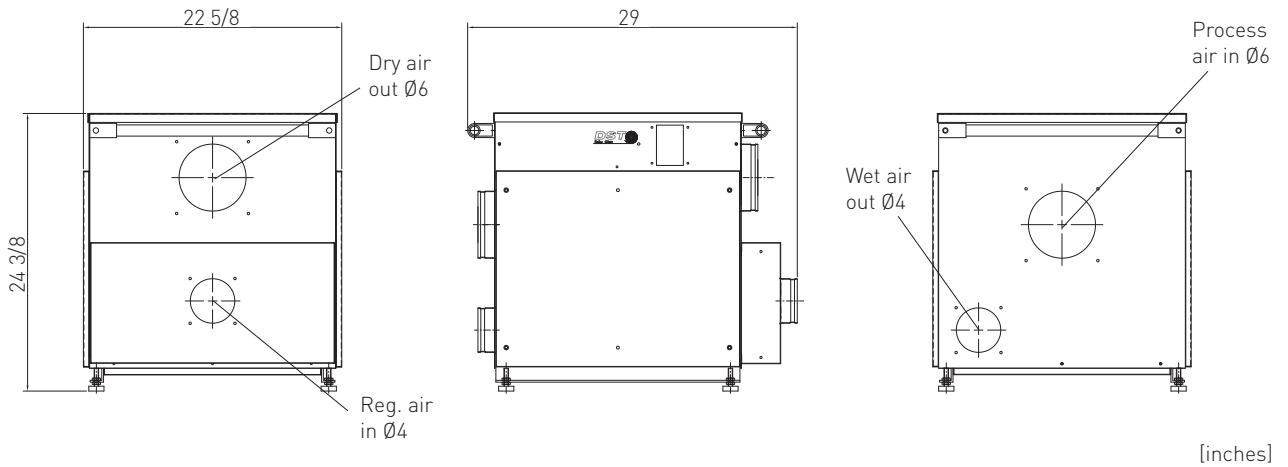

Subject to change without notice. Download installation drawing at www.dst-america.com.