

Dehumidifier Consorb **CZ-82/102/102L/104 ICE**



Dehumidifying capacity at 20°C / 60% RH
23.5 - 69 kg/h

Dry air flow
8 000 - 12 000 m³/h

- Highly efficient D-Max rotor
- No desiccant carry-over
- Suitable for high ambient water contents
- Long lifetime
- High dehumidifying capacity at low moisture contents
- Process fan equipped with frequency converter as standard

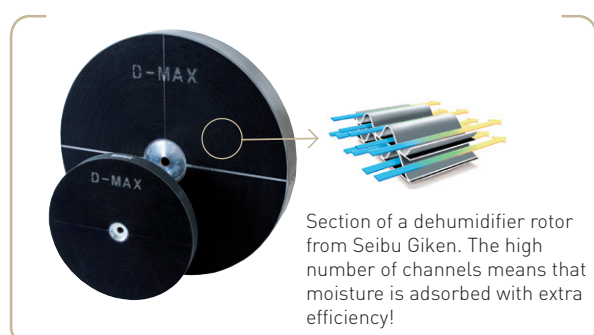

TECHNICAL DATA

Dehumidifier model ICE	CZ-82	CZ-102	CZ-102L	CZ-104
Nominal capacity ¹ (kg/h)	23	39	55	69
Dry air flow ² (m ³ /h)	8 000	12 000	12 000	10 000
at static pressure (Pa)	200	200	200	200
Wet air flow ² (m ³ /h)	850	1 400	2 000	2 500
at static pressure (Pa)	200	200	200	200
Heater power ³ (kW)	30	50	74	95
Max. electric consumption (kW)	36.6	59	83.7	106.5
Supply fuse 3x400V 50Hz (A)	63	100	160	200
Weight (kg)	300	380	400	560

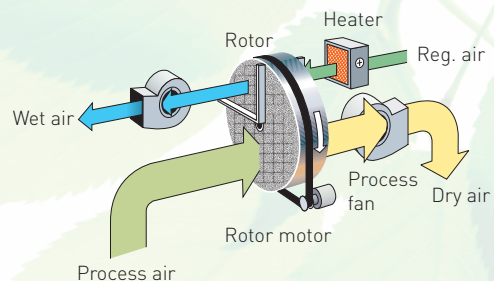

¹ Valid for inlet conditions 20°C/60%RH. For other inlet conditions the capacity can be calculated by using the diagram shown below.

² Volume flow for density 1.20 kg/m³.

³ Electric reactivation heater is standard. Steam and hot water is optional.

CAPACITY

Capacity [kg/h]	10°C			15°C			20°C		
	30%RH	50%RH	70%RH	30%RH	50%RH	70%RH	30%RH	50%RH	70%RH
CZ-082 ICE	15.0	19.0	22.0	17.0	21.0	23.0	18.5	22.0	23.5
CZ-102 ICE	24.0	32.0	36.0	28.0	35.0	39.0	31.0	37.0	39.0
CZ-102L ICE	27.0	40.0	49.0	34.0	47.0	54.0	40.0	51.0	55.0
CZ-104 ICE	25.0	41.0	57.0	34.0	55.0	67.0	46.0	64.0	69.0

DIMENSIONS

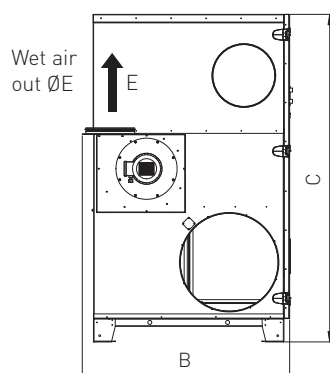
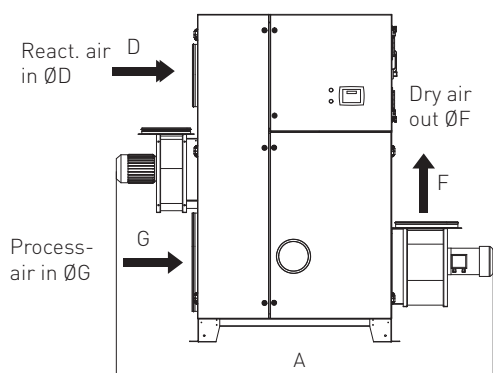

CZ	82	102	102L	104
A	2 840	2 660	2 700	2 890
B	1 065	1 375	1 375	1 265
C	1 905	2 105	2 105	2 105
D	Ø250	Ø400	Ø400	Ø400
E	Ø160	Ø315	Ø315	Ø315
F	786X306	880X338	880X338	880X338
G	Ø400	Ø630	Ø630	Ø630

Subject to change without notice.

Seibu Giken DST AB

Avestagatan 33 | SE-163 53 Spånga, Sweden

Tel +46 8 445 77 20 | Fax +46 8 445 77 39

www.dst-sg.com | info@dst-sg.com