

REVISIONS			
REV.	DESCRIPTION	DATE	APPROVED

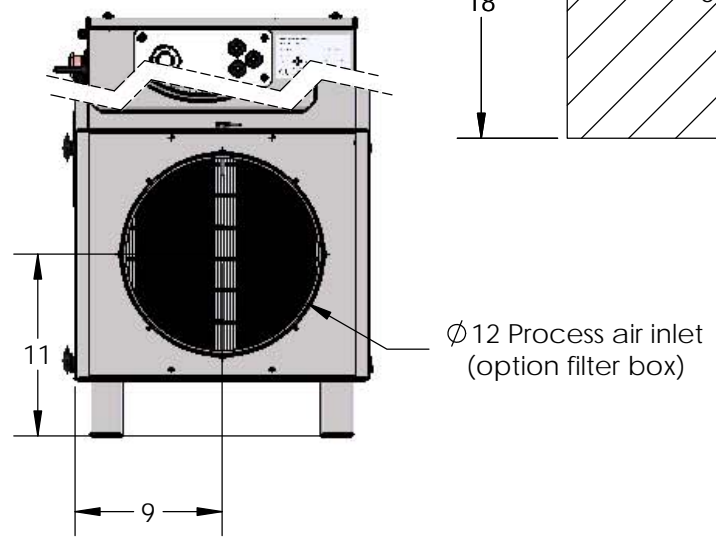

Packaging dimensions:
 LxWxH = 30 x 24 x 45
 weight ~ 160 lbs

This document and its contents are the exclusive property of DST Seibu Giken and must not be copied, reproduced, transmitted or communicated to any other party or used for purposes not expressly permitted by us.

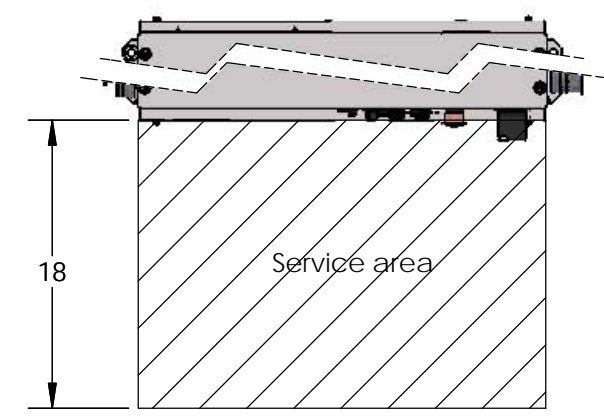
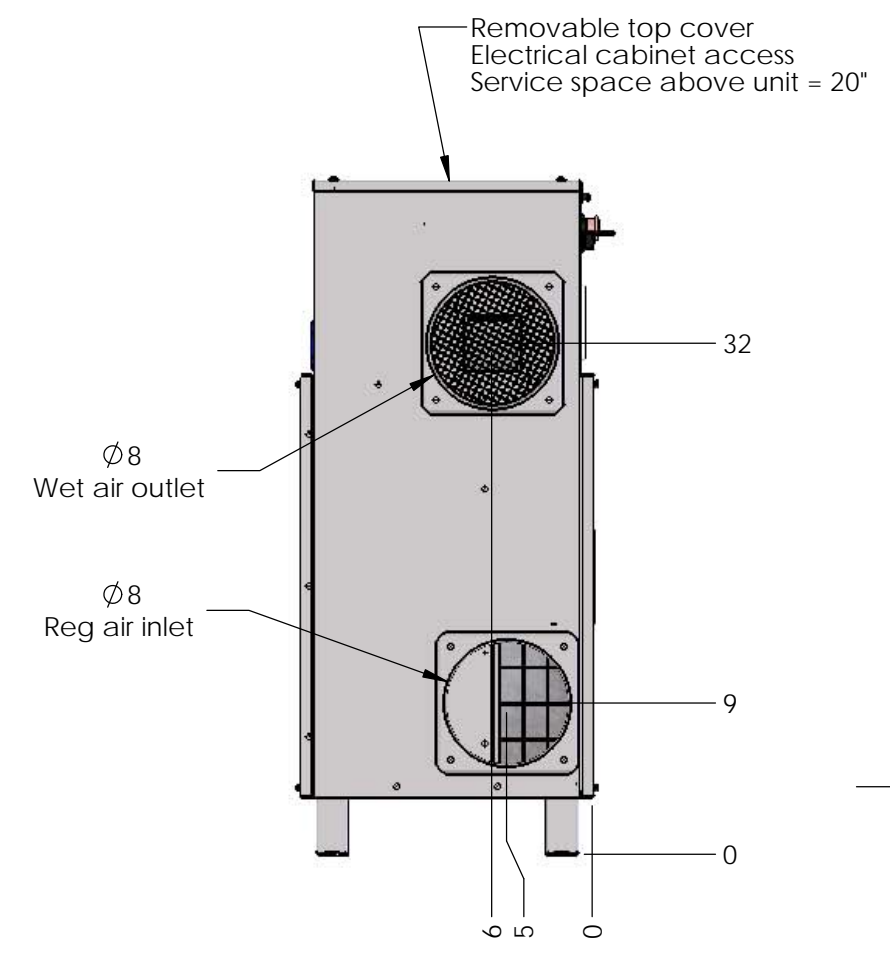
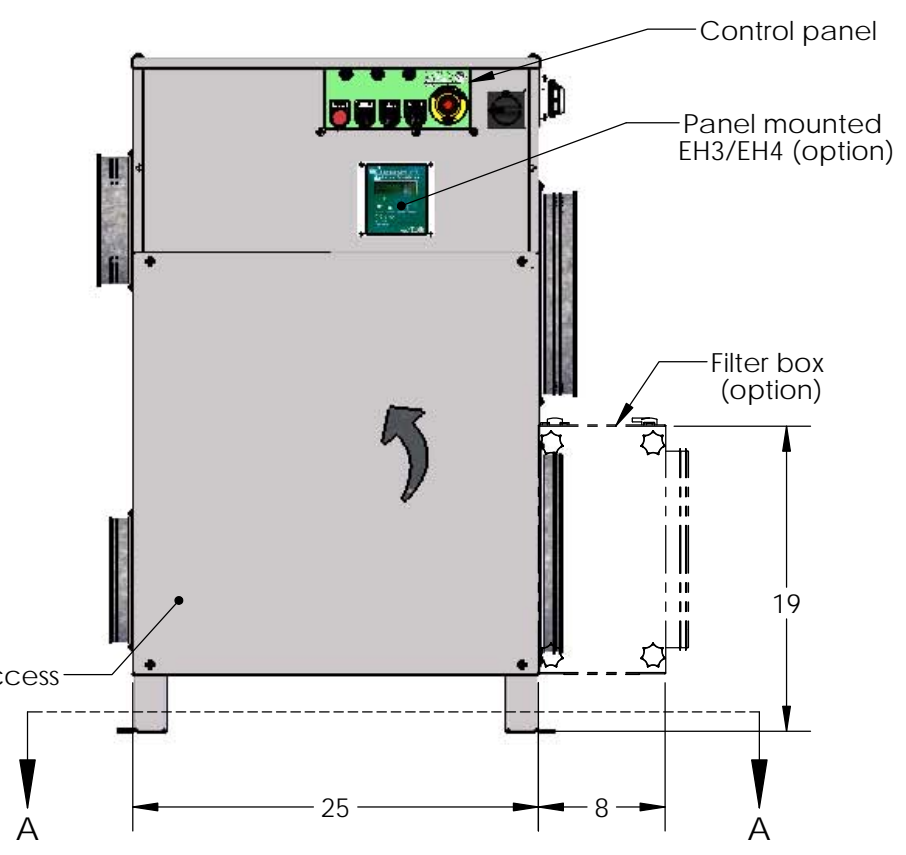
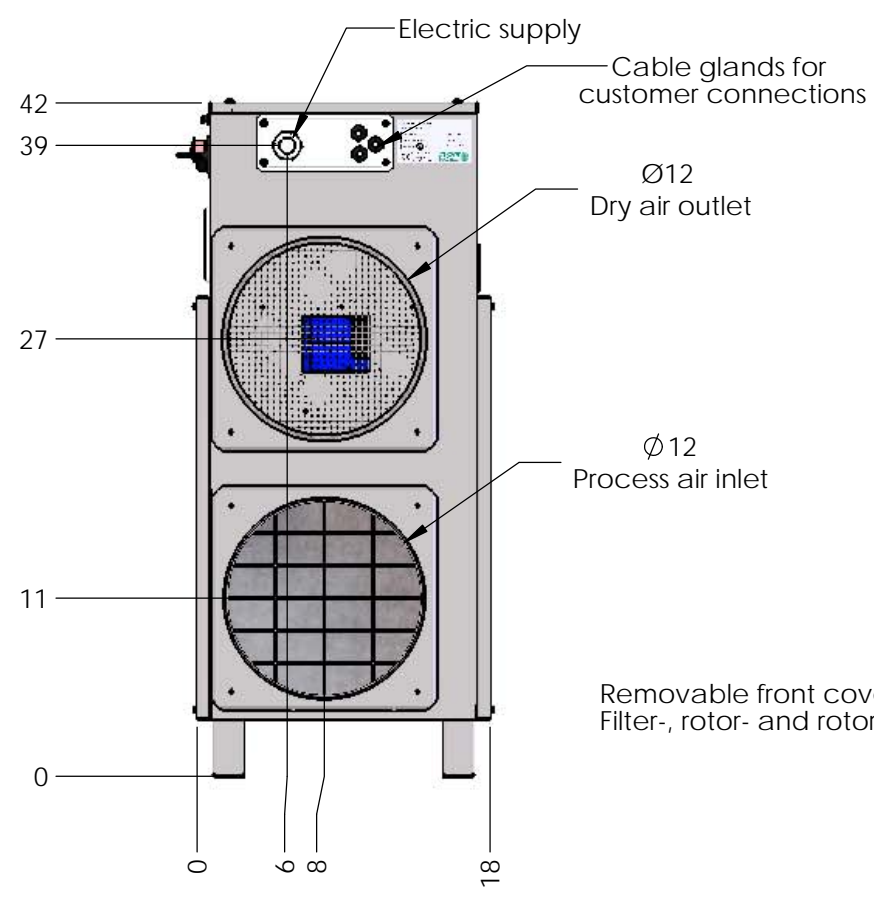
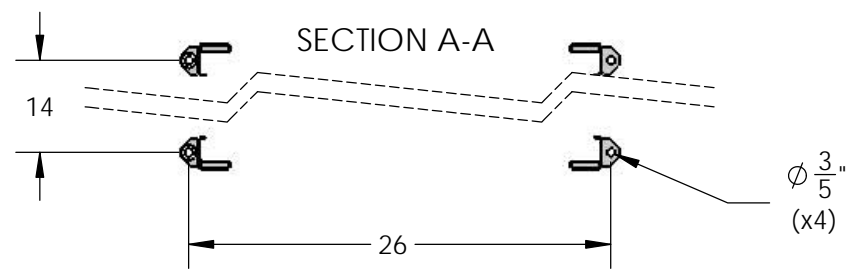

Seibu Giken DST AB
 +46 8 445 77 20
 www.dst-sg.com

Designed by	Erik L	Date	2015-12-23
Drawn by	Erik L	Date	2015-12-23
Approved by	-	Date	-
Material		Thickness	t=
Status	Construction	Tolerance	ISO 2768-1m
Scale	1:12	Format	A3
Sheet/Sheet	1/1	Rev Part	00+
Weight (lbs)	155.000		

Title/Description		
Dimension drawing RL-60SP USA		
RL-60SP		
Drawing no	DST06817	Rev
		00+