

Dehumidifier Recusorb **DR-010B**



Dehumidifying capacity at 68°F / 60%RH

1.1 lbs/hr

Dry air flow

112 CFM

- ↘ Highly efficient D-MAX rotor
- ↘ No desiccant carry-over
- ↘ Stainless steel chassis
- ↘ Self-regulating heater
- ↘ Easy to maintain
- ↘ Long lifetime

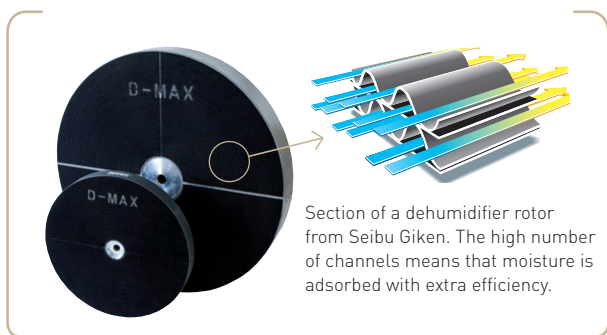

TECHNICAL DATA

Dehumidifier model	DR - 010B
Nominal capacity ¹ (lbs/hr)	1.1
Dry air flow ² (CFM)	112
Wet air flow ² (CFM)	23.5
Heater current ³ (A)	6
Total power (kW)	0.89
Supply fuse 110-115V 60 Hz (A)	10
Weight (lbs)	26

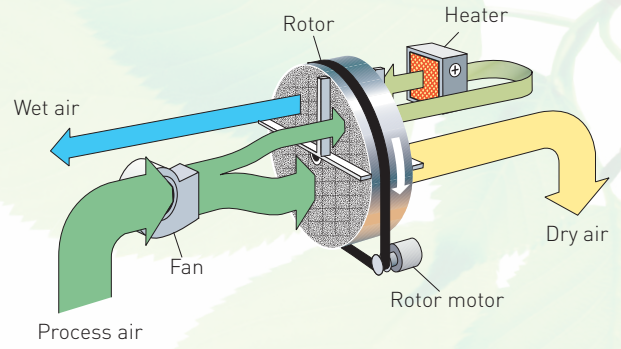

¹ Valid for 68°F/60%RH. For other condition see below table.
² Free blowing at 0.075 lb/ft³.
³ The design of the PTC heater enables the power to be regulated by controlling the wet air flow.

DEHUMIDIFICATION CAPACITY

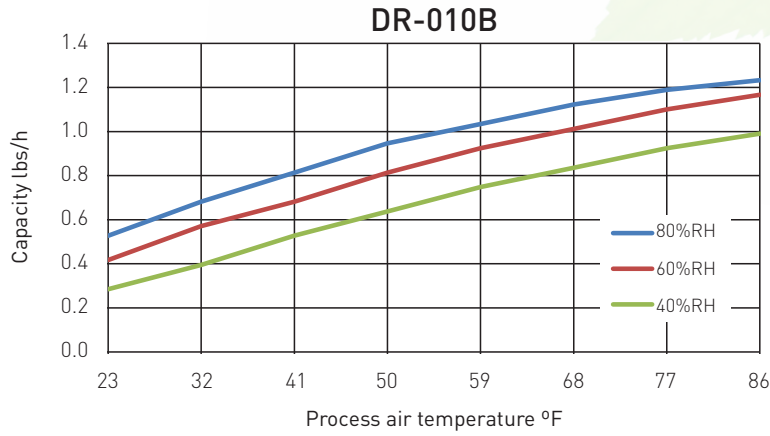

DIMENSIONS

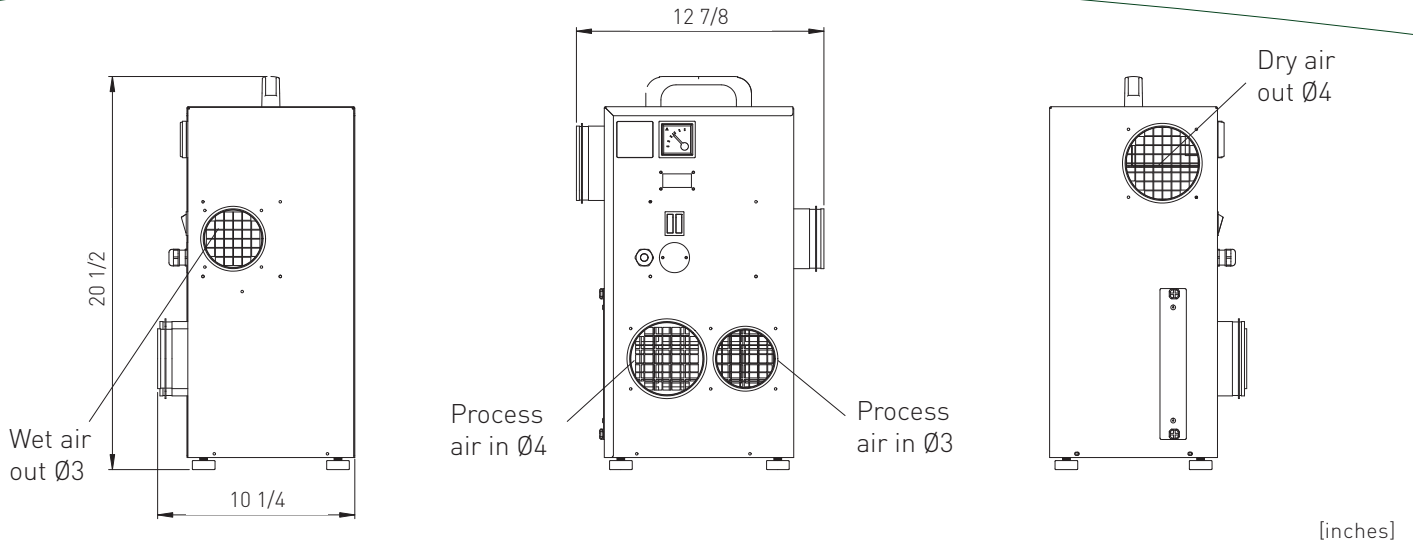

Subject to change without notice. Download installation drawing at www.dst-america.com.