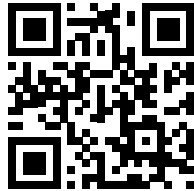




# TAB Centrifugal Fan Air Cooled Condensers

## PRODUCT DATA & INSTALLATION

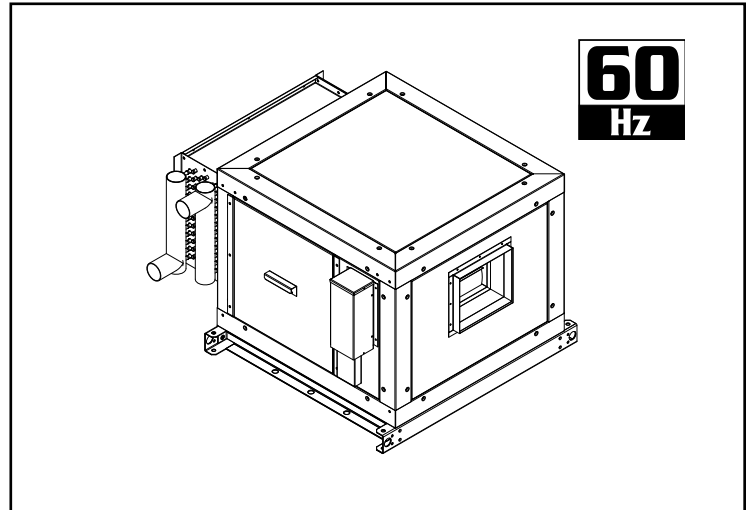


**AIR COOLED MODELS  
FROM 103 THRU 182  
40 TO 115 TONS**

Bulletin T50-TAB-PDI-2

1097722

For the latest product updates and further information, visit [www.trentonrefrigeration.com](http://www.trentonrefrigeration.com)

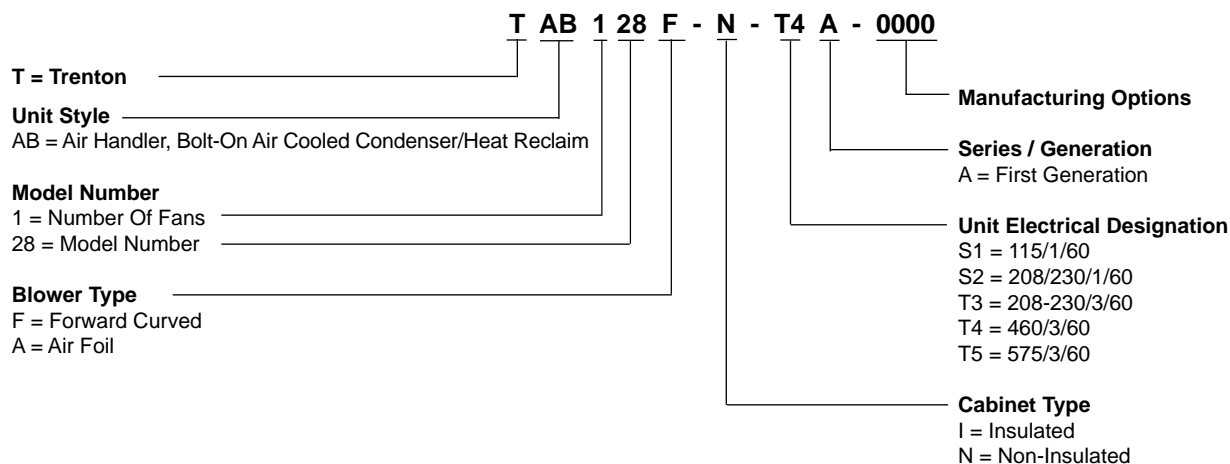


**60  
Hz**

## CONTENTS

	Page
Nomenclature.....	2
Features and Options.....	2
Capacity Data.....	3
Selection Data .....	4
Multiple Compressor Applications.....	5
Blower Components.....	6
Fan Performance Data .....	7
Blower Data.....	8
Calculation of Total Static Pressure .....	9
Component and Air Friction .....	10
Sound Data .....	10
Performance and Physical Data .....	11 - 12
Fan Motor Locations .....	13
Dimensional Data.....	14 - 19
Engineering Specifications.....	20
Installation and Assembly Instructions.....	21 - 22
Lifting Instructions .....	23 - 24
Wiring Diagrams.....	25
Electrical Data.....	26 - 27
Maintenance .....	28
Approximate Weights .....	29
Optional Internal Spring Isolators .....	30
Warranty.....	31
Project Information.....	31

# NOMENCLATURE



## STANDARD FEATURES

- **Indoor Applications Only** ● Large Face Area Centrifugal Fan
  - “Bolt-On” Coil for Maximum Capacity in Minimum Space
  - Single Wall Heavy Gauge Galvanized Cabinet
- Full Size Access Doors for Easy Maintenance ● Efficient Forward Curved Blower
  - 14 Models ● Up to 6” Total Static Pressure
  - Up to 55,000 CFM ● Internal Motor ● Up to 50 HP
    - Horizontal and Vertical Air Discharge
    - External Electrical Box Mounted to Cabinet
    - Extended Grease Lines with External Access

## OPTIONAL FEATURES (Factory Mounted)

- Double Wall Cabinet with 2” mineral wool Insulation
  - Internal Vibration Isolators
  - Airfoil (Up to 8” Total Static Pressure)
    - Disconnect Switch ● Flat Filter
    - Angle Filters

**OTHER OPTIONS ARE AVAILABLE AT YOUR REQUEST. CONSULT FACTORY FOR PRICING.**

Table 1

TAB MODEL NUMBER	TOTAL HEAT OF REJECTION BTU/hr					
	TEMPERATURE DIFFERENCE (TD) R404A					
	1 °F	10 °F	15 °F	20 °F	25 °F	30 °F
103	1750	17500	26250	35000	43750	52500
104	2650	26500	39750	53000	66250	79500
106	3780	37800	56700	75600	94500	113400
108	5040	50400	75600	100800	126000	151200
111	6720	67900	100800	134400	168000	201600
114	8590	85900	128850	171800	214750	257700
117	10190	101900	152850	203800	254750	305700
122	12640	126400	189600	252800	316000	379200
128	15870	158700	238050	317400	396750	476100
137	20820	208200	312300	416400	520500	624600
141	24440	244400	366600	488800	611000	733200
150	28110	281100	421650	562200	702750	843300
164	35480	354800	532200	709600	887000	1064400
182	46100	461000	691500	922000	1152500	1383000

## HEAT REJECTION CAPACITY PER FACE TUBE - R404A

Table 2

TAB MODEL NUMBER	FACE TUBES	TOTAL HEAT OF REJECTION BTU/hr					
		TEMPERATURE DIFFERENCE (TD) R404A					
		1 °F	10 °F	15 °F	20 °F	25 °F	30 °F
103	12	146	1460	2190	2920	3650	4380
104	14	189	1890	2835	3780	4725	5670
106	16	236	2360	3540	4720	5900	7080
108	22	229	2290	3435	4580	5725	6870
111	22	305	3050	4575	6100	7625	9150
114	22	390	3900	5850	7800	9750	11700
117	22	463	4630	6945	9260	11575	13890
122	26	486	4860	7290	9720	12150	14580
128	26	610	6100	9150	12200	15250	18300
137	34	612	6120	9180	12240	15300	18360
141	40	611	6110	9165	12220	15275	18330
150	46	611	6110	9165	12220	15275	18330
164	58	612	6120	9180	12240	15300	18360
182	58	795	7950	11925	15900	19875	23850

### Correction Factors for Other Refrigerants

Use **R404A** Values Multiplied By:

	TD (Condensing dew point temperature - ambient temperature)																				
	10	11	12	13	14	15	16	17	18	19	20	21	22	23	24	25	26	27	28	29	30
<b>R407C</b> (4)	0.67	0.69	0.72	0.73	0.75	0.77	0.78	0.80	0.81	0.82	0.83	0.84	0.85	0.86	0.86	0.87	0.87	0.88	0.88	0.89	0.89
<b>R22</b>	1.02																				
<b>R507</b>	1.00																				
<b>R134a</b>	0.97																				
<b>R410A</b>	1.02																				

**NOTES:**

- (1) Capacity based on 12 FPI, 6 rows and 1/2" O.D. tubes.
- (2) Above capacity data based on 0°F subcooling and at sea level.
- (3) TD = Condensing temperature - ambient temperature.

## MULTIPLE CIRCUIT CONNECTION SIZES

Table 3

NET TONS		3 - 9 †	9.5 - 12	12.5 - 16	16.5 - 22	22.5 - 34	34.5 - 42	42.5 - 52	52.5 - 68	68.5 - 77	77.5 - 95
HOT GAS INLET	inches	1 1/8	1 3/8	1 3/8	1 5/8	2 1/8	2 1/8	2 5/8	2 5/8	3 1/8	3 1/8
LIQUID OUTLET	inches	7/8	7/8	1 1/8	1 1/8	1 3/8	1 5/8	1 5/8	2 1/8	2 1/8	2 5/8

† - On a circuit that uses only 1 face tube, a connection tube will be provided instead of a header. When used as a desuperheater, the inlet and outlet connections will be the same and based on Hot Gas sizing.

The selection of an air cooled condenser is based on the heat rejection capacity at the condenser rather than net refrigeration effect at the evaporator because the refrigerant gas absorbs additional energy in the compressor. This additional energy, the heat of compression, varies appreciably with the operating conditions of the system and with compressor design, whether open or suction cooled hermetic type.

Some compressor manufacturers publish heat rejection figures as part of their compressor ratings. Since heat rejection varies with compressor design, it is recommended that the compressor manufacturer's data be used whenever available in selecting an air cooled condenser.

If the compressor manufacturer does not publish heat rejection ratings, factors from Table Nos. 4 and 5 may be used to estimate total heat rejection-THR.

For systems outside the normal limits of single stage compressor application, (such as compound or cascade refrigeration systems) the following formulas may be used to arrive at the heat rejection requirements for selection of the condenser:

Open Compressors

$$THR = \text{Compressor Capacity (BTUH)} + 2545 \times \text{BHP}$$

Suction Cooled Hermetic Compressors

$$THR = \text{Compressor Capacity (BTUH)} + 3413 \times \text{KW}$$

## HEAT REJECTION FACTORS

### CONDENSER LOAD = COMPRESSOR CAPACITY X FACTOR

**TABLE 4:  
OPEN COMPRESSORS**

EVAP. TEMP		CONDENSING TEMPERATURE - °F (°C)					
°F	°C	90 (32)	100 (38)	110 (43)	120 (49)	130 (54)	170 (60)
-30	-34	1.37	1.42	1.47	-	-	-
-20	-29	1.33	1.37	1.42	1.47	-	-
-10	-23	1.28	1.32	1.37	1.42	1.47	-
0	-18	1.24	1.28	1.32	1.37	1.41	1.47
10	-12	1.21	1.24	1.28	1.32	1.36	1.42
20	-7	1.17	1.2	1.24	1.28	1.32	1.37
30	-1	1.14	1.17	1.2	1.24	1.27	1.32
40	4	1.12	1.15	1.17	1.2	1.23	1.28
50	10	1.09	1.12	1.14	1.17	1.2	1.24

**TABLE 5:  
SUCTION COOLED HERMETIC COMPRESSORS**

EVAP. TEMP		CONDENSING TEMPERATURE - °F (°C)					
°F	°C	90 (32)	100 (38)	110 (43)	120 (49)	130 (54)	170 (60)
-30	-34	1.57	1.62	1.68	-	-	-
-20	-29	1.49	1.53	1.58	1.65	-	-
-10	-23	1.42	1.46	1.50	1.57	1.64	-
0	-18	1.36	1.40	1.44	1.50	1.56	1.62
10	-12	1.31	1.34	1.38	1.43	1.49	1.55
20	-7	1.26	1.29	1.33	1.37	1.43	1.49
30	-1	1.22	1.25	1.28	1.32	1.37	1.42
40	4	1.18	1.21	1.24	1.27	1.31	1.35
50	10	1.14	1.17	1.20	1.23	1.26	1.29

## SELECTION EXAMPLE

### GIVEN:

Compressor Capacity: 310,000 Btuh  
 Evaporator Temperature: 30°F.  
 Refrigerant: R-404A  
 Ambient Air: 95°F.  
 Maximum Condensing Temp.: 110°F.  
 Suction Cooled Hermetic Compressor

### PROCEDURE:

- (1) Assuming the compressor manufacturer's heat rejection data is not available, determine the heat rejection factors for the specified conditions from Table No. 5 above (1.28).
- (2) Multiply the compressor capacity by the heat rejection factor to estimate the required condenser capacity.

- (3) Since R-404A is specified, select the proper condenser from Capacity Data tables (page 3) based on the specified difference between condensing refrigerant and the ambient air (T.D.).

### SELECTION:

Using the heat rejection factor from Table No. 4 above, the required condenser capacity is:

$$1.28 \times 310,000 = 396,800 \text{ Btuh}$$

From Capacity Data tables (page 3) for the specified T.D. of 15°F the proper selection is the Model AB 150 with a capacity of 421,650 Btuh. In this instance the condenser is slightly oversized and the condenser will balance the compressor heat rejection at less than the maximum condensing temperature of 110°F.

Multi circuit condenser coils are available for applications where more than one compressor is used, either on the same system or separate systems.

Multi circuit condensers are factory circuited to meet the specified capacities.

The fan on a multi circuited unit should remain operative as long as a condensing requirement exists on any circuit of the coil.

## SELECTION EXAMPLE

### GIVEN:

Six hermetic compressors with capacities and evaporator temperatures (tabulated below).

Refrigerant: R-404A

Ambient Air Temperature 90°F.

Maximum Condensing Temp.: 110°F.

### PROCEDURE:

1. Tabulate the compressor capacities, evaporator temperatures and heat rejection factors for each compressor. (See Sample Tabulation, below.)
2. Determine the required heat rejection capacity for each compressor.
3. Total the sectional heat rejection capacities for the six compressors.

### SELECTION:

Based on the total heat rejection capacity for the six compressors of 186,160 BTUH, it can be seen from Table No. 2 that the smallest unit which will meet this requirement is the Model AB 117 with 203,800 BTUH at 20 °F. T.D. Table No. 2 lists the heat rejection capacity per "face tube" at various T.D.'s.

At 20 °F. T.D., the AB 117 has a capacity of 9260 Btuh per "face tube". To determine the required number of face tubes for each section, divide the required sectional capacity by the capacity per "face tube". For example, compressor No. 1 requires  $18,000 : 9260 = 2$  "face tubes". Section No. 1 should be circuited with 2 "face tubes" for Compressor No. 1. Following this same procedure will determine the size of each section for the remaining compressors.

The sample tabulation shows the results of this selection and indicates that 22 "face tubes" are required when using the Model AB 117. Since the Model AB 117 has 22 "face tubes" available, the selection has been satisfied. If the total required number of "face tubes" exceeds the number of "face tubes" available as listed in Table No. 2 it will be necessary to permit a slightly higher condensing temperature than planned for one or two of the sections. A second alternative would be to select the next larger size condenser.

## SAMPLE TABULATION

No. of COMPRESSOR	COMPRESSOR CAPACITY (BTUH)	EVAPORATOR TEMPERATURE		HEAT REJECTION FACTOR	REQUIRED CONDENSER CAPACITY (BTUH)	REQUIRED NUMBER OF FACE TUBES
		°F	°C			
1	13500	+20	-7	1.37	18000	2
2	10000	-15	-23	1.57	17440	2
3	36000	+15	-9	1.40	51400	6
4	11000	+20	-7	1.37	15070	2
5	31000	-10	-23	1.57	50000	6
6	25000	+20	-7	1.37	<u>34250</u>	<u>4</u>
				total:	186160	22

## FEATURES A NEW ADVANCED DYNAMIC DESIGN BLOWER SECTION

- **HIGH EFFICIENCY FAN PERFORMANCE**
- **FANS TESTED PER AMCA CODE No. 210**
  - **MINIMUM FAN TIP SPEEDS**
  - **CLASS II CONSTRUCTION**

The air handler blower section is a matched assembly combining advanced engineering techniques with the finest materials available.

Forward-curved centrifugal fans were designed specifically to operate at low tip-speeds with minimum power consumption. To meet the low noise level requirements of comfort air conditioning, fan outlet velocities have been reduced without sacrificing good fan performance. Blowers are fully performance tested and certified in accordance with DIN, ISO, BS and AMCA 210 standards. Blowers are rated for CLASS II operation and have bearings selected to guarantee a minimum L50 life time of 200,000 hours. The fan section is complete with a rugged drive assembly. The heavy duty motor base is designed for quick and simple belt adjustment. All drives are furnished with matched V-belts.

**EXCLUSIVE STEEL FRAME CONSTRUCTION**

Sectionalized construction provides complete flexibility of unit arrangements with each individual section structurally designed to provide the absolute maximum in unit strength and rigidity. All static and dynamic forces are directly transmitted to the unit framework. The blowers are supported entirely by rigid frame members, eliminating all dynamic forces from the casing panel. Optional internal blower isolators are also available on all models.

For maximum durability, the entire cabinet assembly is fabricated of continuous galvanized steel. This heavy protective finish is maintained intact, completely undisturbed and is complimented with the use of corrosion resistant permanent fasteners. The positive fastening principle of a permanent fastener provides the rigidity and stability necessary for lifetime performance. Optional 2" insulated panels are available on all models. Outdoor construction is available on all models. These exclusive construction features offer you the ultimate in air handling design.

**INTERNAL BLOWER CONSTRUCTION**

All blower housings are manufactured in galvanized sheet steel. Impellers are also manufactured in galvanized sheet steel with tab locked blades. All impellers are balanced, both statically and dynamically, to an accuracy grade of G = 6.3 in accordance to DIN ISO 1940-1 and ANSI S2.19 – 1989. Bearings are self-aligning, single row, and deep groove ball type, in pillow block cast iron housings. All bearings have been selected to guarantee a minimum L50 life time of 200,000 hours. Operating temperatures range from -25°F to + 131°F (-31°C to +55°C) for all blowers. For operating temperatures outside these limits please consult factory. Extended lubrication lines are standard. Airfoil constructed blowers available for all models for static pressures above 6" – consult factory (models 103 & 104 excluded).

## DETERMINATION OF FAN SPEED AND MOTOR HP REQUIREMENTS

Final determination of the actual fan performance requires an accurate calculation of the total resistance to air flow through the entire system. This total static pressure (TSP) will consist of two parts: (1) the external resistance due to air flow through the ducts, discharge grilles, diffusers, etc. of the distribution system, and (2) the internal resistance of the unit which results from air flow through the coils, filters, unit cabinet and other accessories. The method of calculating the resistance for the various components of the distribution system are well established. The internal resistances are easily determined from Blower Data table (see page 4) which tabulates the resistance values for the various unit components in increments of air volume. For the internal resistances as shown in Blower Data table (see page 4). The resistances of the cooling coil must be added. These may be obtained from the charts on page 4. After calculating the total static pressure, the fan speed and motor horsepower requirements can be accurately determined. With the unit model, CFM and TSP known, the fan RPM and BHP is easily determined from the Blower Data Tables. (page 9)

## FAN PERFORMANCE INFORMATION

This catalogue contains all of the blower data for central station air handlers. Units are equipped with forward curved fan wheels as standard.

## SELECTION RULES

The fan performance calculation procedure is predicated on the fact that a fan is a constant volume machine, provided the RPM and static pressure do not change. This means the delivered air volume (CFM) will not change, even though the temperature may. The BHP required is inversely proportional to final air temperature and altitude; consequently BHP decreases with an increase in final air temperature or higher altitude and increases with a decrease in final air temperature or lower altitude. This requires that the static pressure be adjusted for any air conditions other than standard. After the calculation of RPM and BHP, only the BHP need be corrected to the specified conditions.

## SELECTION PROCEDURE

The following data is required to determine the \_\_\_\_\_. The unit type, unit size, CFM, total static pressure, operating temperature and altitude.

1. From table below, obtain the temperature and altitude conversion factor.
2. Divide the specified total static pressure by the conversion factor to obtain a corrected total static pressure.
3. At the specified CFM and corrected total static pressure, determine the RPM and BHP. (page 9)
4. Multiply the BHP by the conversion factor to obtain the BHP required at the specified altitude and temperature.

## EXAMPLE OF SELECTION PROCEDURE

TAB111 with 5000 CFM @ 1.0" total static pressure, 20°F air temp, 5000 feet elevation:

1. Conversion factor = 0.92
2. New TSP = 1.0" / 0.92 = 1.09"
3. 1.09" = 586 RPM and 1.35 BHP
4. New BHP = 1.35 x 0.92 = 1.24

Selection = 5000 CFM @ 586 RPM and 1.24 BHP

## TEMPERATURE AND ALTITUDE CONVERSION FACTORS

AIR TEMP. °F	ALTITUDE (FEET)								
	0	1000	2000	3000	4000	5000	6000	7000	8000
-20	1.2	1.16	1.12	1.08	1.04	1	0.97	0.93	0.89
0	1.15	1.1	1.08	1.02	0.99	0.95	0.92	0.88	0.85
20	1.11	1.06	1.02	0.98	0.95	0.92	0.88	0.85	0.82
40	1.06	1.02	0.98	0.94	0.91	0.88	0.84	0.81	0.78
60	1.02	0.98	0.94	0.91	0.88	0.85	0.81	0.79	0.76
70	1	0.96	0.93	0.89	0.86	0.83	0.8	0.77	0.74
80	0.98	0.94	0.91	0.88	0.84	0.81	0.78	0.75	0.72
100	0.94	0.91	0.88	0.84	0.81	0.78	0.75	0.72	0.7
120	0.92	0.88	0.85	0.81	0.78	0.76	0.72	0.7	0.67
140	0.89	0.85	0.82	0.79	0.76	0.73	0.7	0.68	0.65

## BLOWER DATA (Based on DUCTED OUTLET)

### Fan RPM and Motor HP Requirements

MODEL AB	NOMINAL CFM	STANDARD - 6 ROW COIL ONLY		TOTAL STATIC PRESSURE (Inches - Water Gauge) (Includes Coil, Ductwork etc.)												CABINET SP (In. W.G)
		0.55 + CABINET SP		0.75		1.00		1.50		2.00		2.5		3.0		
		RPM	BHP	RPM	BHP	RPM	BHP	RPM	BHP	RPM	BHP	RPM	BHP	RPM	BHP	
103	2000	991	0.62	1035	0.66	1134	0.75	1314	0.93	1480	1.12	1640	1.33	1794	1.56	0.1
104	3150	959	1.24	981	1.28	1050	1.4	1191	1.64	1328	1.9	1461	2.19	1590	2.5	0.13
106	4500	832	1.76	854	1.82	931	2.03	1072	2.45	1198	2.87	1313	3.31	1422	3.76	0.13
108	6000	647	2.12	658	2.16	713	2.41	823	2.9	928	3.42	1030	3.99	1129	4.62	0.16
111	8000	539	2.32	564	2.47	617	2.83	714	3.55	805	4.3	891	5.08	975	5.9	0.09
114	10000	606	3.9	629	4.09	675	4.53	760	5.41	840	6.31	915	7.23	988	8.17	0.09
117	12000	677	6.19	699	6.41	742	6.91	819	7.95	891	9.01	958	10.1	1023	11.2	0.08
122	15000	562	6.61	574	6.8	612	7.41	685	8.75	755	10.2	823	11.7	890	13.2	0.12
128	19000	482	8.17	500	8.62	532	9.5	594	11.3	655	13.1	715	15	773	16.9	0.07
137	23000	413	9.46	428	9.91	458	11	517	13.2	572	15.4	625	17.6	678	19.9	0.09
141	29000	373	11.99	380	12.3	407	13.6	459	16.3	508	19.1	556	22	603	24.9	0.14
150	34000	329	14.05	333	14.2	357	15.3	405	18.1	451	21.2	493	24.5	534	27.9	0.17
164	42000	293	15.98	292	15.8	316	17.9	360	22	400	26	438	30.1	474	34.2	0.22
182	55000	269	21.1	272	21.4	291	24	328	29.2	364	34.4	399	39.6	434	45.1	0.17

## BLOWER DATA (Based on FREE OUTLET)

MODEL AB	NOMINAL CFM	STANDARD - 6 ROW COIL ONLY		TOTAL STATIC PRESSURE (Inches - Water Gauge) (Includes Coil, no discharge duct work)												CABINET SP (In. W.G)
		0.55 + CABINET SP		0.75		1.00		1.50		2.00		2.5		3.0		
		RPM	BHP	RPM	BHP	RPM	BHP	RPM	BHP	RPM	BHP	RPM	BHP	RPM	BHP	
103	2000	1108	0.72	1142	0.76	1225	0.84	1384	1.01	1537	1.19	1687	1.4	1835	1.63	0.1
104	3150	1097	1.48	1114	1.51	1175	1.62	1298	1.85	1421	2.1	1541	2.38	1660	2.7	0.13
106	4500	978	2.17	995	2.22	1054	2.41	1169	2.78	1277	3.17	1380	3.59	1479	4.02	0.13
108	6000	735	2.51	743	2.55	791	2.76	887	3.22	982	3.72	1076	4.29	1167	4.9	0.16
111	8000	611	2.79	630	2.93	674	3.25	759	3.93	842	4.64	923	5.39	1001	6.18	0.09
114	10000	711	4.9	727	5.06	763	5.45	834	6.25	903	7.08	970	7.94	1036	8.83	0.09
117	12000	818	7.94	833	8.15	863	8.61	923	9.53	982	10.49	1040	11.47	1097	12.48	0.08
122	15000	659	8.26	669	8.44	700	9.04	761	10.31	822	11.66	882	13.07	942	14.53	0.12
128	19000	567	10.52	581	10.91	607	11.69	660	13.3	713	14.97	767	16.71	820	18.53	0.07
137	23000	486	12.02	497	12.43	522	13.39	570	15.35	618	17.35	666	19.42	714	21.54	0.09
141	29000	436	15.02	441	15.3	463	16.5	506	18.99	550	21.57	593	24.24	635	26.98	0.14
150	34000	384	16.78	386	16.92	406	18.18	446	20.91	486	23.86	524	26.99	561	30.27	0.17
164	42000	336	19.73	334	19.59	353	21.37	389	25.01	425	28.73	459	32.51	493	36.38	0.22
182	55000	309	26.7	311	26.96	327	29.2	359	33.78	392	38.53	423	43.52	455	48.76	0.17

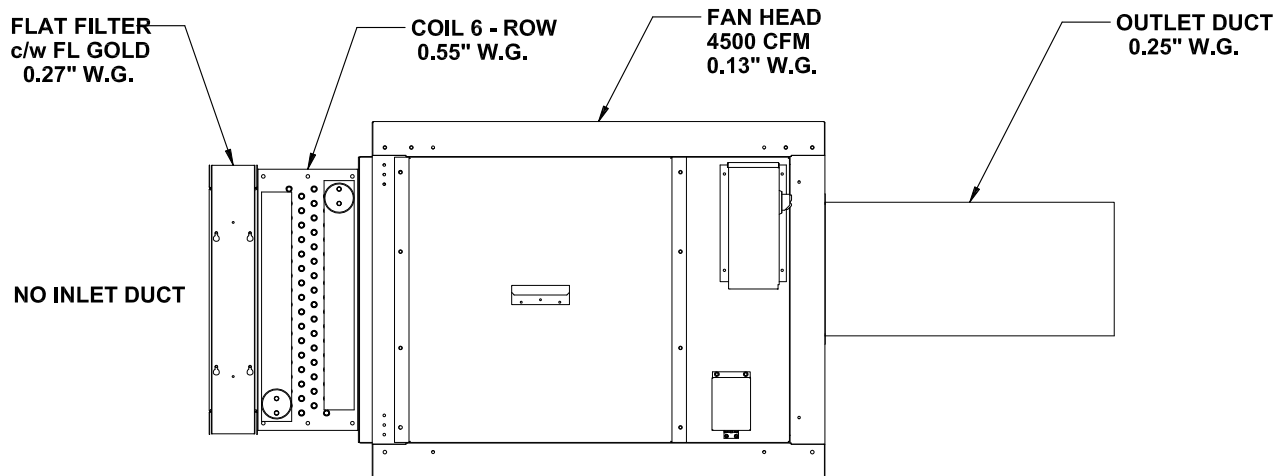


### Example #1

1. Select model based on CFM requirement and estimated static pressure.
2. Example model selected TAB106F-N-T3A- 4500 CFM @ 0.25" ESP.
3. Verify total internal airside resistance using charts on page 7.
  - a) For coil static pressure ref. page 9 - 0.55" used for 6 Row Coil.
  - b) For cabinet static pressure ref. page 9 - 0.13"
  - c) For filter area ref. page 11 (4500 CFM / 8.4 ft<sup>2</sup>) = 535 FPM.
  - d) For filter static pressure ref. page 10 - FL GOLD @ 535 FPM = 0.27"
  - e) external duct is example only - used 0.25"
4. Recalculate total static press -  $TSP = 0.27" + 0.55" + 0.13" + 0.25" = 1.2"$

**Note: this example does not allow for detailed velocity inlet and outlet pressure.**

### Model: TAB106F-N-T3A-



### CALCULATE TOTAL STATIC PRESSURE (TSP)

$$TSP = 0.27" + 0.55" + 0.13" + 0.25" = 1.2"$$

FROM BLOWER DATA CHART: 4500 CFM  
2.25 BHP  
990 RPM

FILTER FACE VELOCITY	FARR 30/30		FARR 44	FL GOLD	ALUM. MESH
	(throw-aways)		(washable)	(metal / Renu frame)	(washable)
FPM	2"	4"	2"	2"	2"
250	0.1	0.08	0.03	0.1	0.08
300	0.14	0.12	0.05	0.13	0.1
350	0.17	0.15	0.06	0.15	0.12
400	0.21	0.19	0.07	0.18	0.15
450	0.26	0.23	0.09	0.21	0.18
500	0.31	0.27	0.11	0.25	0.21
550	NR	NR	0.14	0.29	0.24
600	NR	NR	0.16	0.33	0.27

To determine filter face velocity, divide the CFM by the filter area (see Physical Data table).

NR = Not Recommended

Ratings are at initial resistance.

## SOUND DATA

### SOUND

with the necessary attenuation analysis, which may include considerations of unit placement (away from occupied areas), acoustical insulation in the equipment room, duct silencers, or acoustical duct lining.

### SOUND POWER LEVEL ESTIMATING

The following method of estimating centrifugal fan sound power level spectrums is taken from the latest ASHRAE sources. The method does not take into consideration such factors as cabinet attenuation or inefficient unit selection, but does provide conservative approximate values upon which to base an acoustical attenuation analysis.

Sound power levels in decibels are 10-12 watts in each of the eight octave bands may be estimated with the following formula:

$$\text{dB} = (\text{Base dB}) + (\text{System dB}) + (\text{Blade Passage Frequency dB})$$

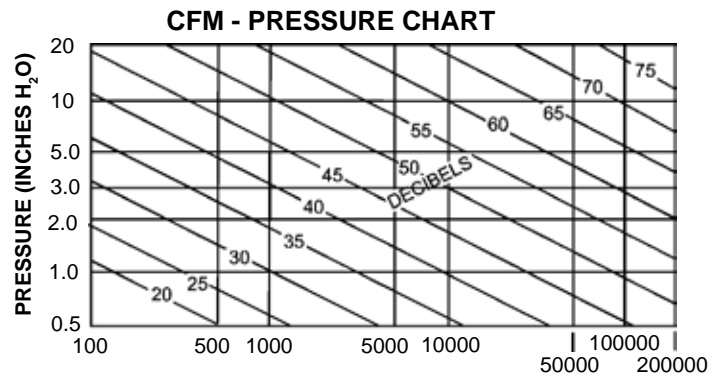
### Base dB

The base dB is found in the table below by entering the octave band and reading the dB in the appropriate row.

OCTAVE BAND CENTRE FREQUENCY								
Hz	63	125	250	500	1000	2000	4000	8000
dB	47	43	39	33	28	25	23	20

### SYSTEM dB

The system dB is found in the chart below by entering the chart at the flow rate, rise vertically to the pressure of the system and read the decibels



### BLADE PASSAGE FREQUENCY dB

The Blade Passage Frequency dB is found:

1. For forward curved fan wheel units - add 2 dB to the one octave band which contains the frequency equal to the RPM of the fan.
2. For airfoil units - add 3 dB to the one octave band which contains the frequency equal to the RPM of the fan.

DESCRIPTION		UNIT SIZE							
		103	104	106	108	111	114	117	
CFM RANGE		HEATING	700-2000	1000-3200	1800-5000	2200-7000	3000-10000	4000-13000	5000-15000
STANDARD FAN DATA	FORWARD CURVED	Outlet Area - Square Feet	0.84	1.03	1.45	2.04	2.86	2.86	2.86
		Number - Diameter (in) - Type	1 - 9 FC	1 - 10 FC	1 - 12 FC	1 - 15 FC	1 - 18 FC	1 - 18 FC	1 - 18 FC
		Shaft and Bearing Size (in)	3/4	3/4	1 3/16	1 3/16	1 7/16	1 7/16	1 7/16
OPTIONAL FAN DATA	AIRFOIL	Outlet Area - Square Feet	N/A	N/A	1.45	2.04	2.86	2.86	2.86
		Number - Diameter (in) - Type			1 - 12 AF	1 - 15 AF	1 - 18 AF	1 - 18 AF	1 - 18 AF
		Shaft and Bearing Size (in)			1 3/16	1 7/16	1 1/2	1 1/2	1 1/2
COIL DATA	Number - Size (in)		18 x 30	21 x 36	24 x 45	33 x 44	33 x 58	33 x 74	33 x 88
	Face Area - Square Feet		3.75	5.25	7.5	10.08	13.29	16.96	20.17
	Number of Face Tubes		12	14	16	22	22	22	22
	STANDARD 6 ROW COIL: Normal Refrigerant Operating Charge (lbs.) see notes below		4.6	6.3	8.9	12	15.6	19.7	23.3
FILTER DATA	2" FLAT FILTER SECTION	Number - Size (in)	2 - 16x20x2	2 - 20x20x2	3 - 16x25x2	2 - 16x20x2 2 - 16x25x2	6 - 16x20x2	6 - 16x25x2	4 - 16x20x2 4 - 16x25x2
		Filter Area - Square Feet	4.4	5.6	8.4	10	13.3	16.7	20
	4" FLAT FILTER SECTION	Number - Size (in)	2 - 16x20x4	2 - 20x20x4	3 - 16x25x4	2 - 16x20x4 2 - 16x25x4	6 - 16x20x4	6 - 16x25x4	4 - 16x20x4 4 - 16x25x4
		Filter Area - Square Feet	4.4	5.6	8.4	10	13.3	16.7	20
	2" ANGULAR FILTER SECTION	Number - Size (in)	N/A	N/A	N/A	N/A	N/A	2 - 16x25x2 6 - 20x25x2	8 - 20x25x2
		Filter Area - Square Feet						26.4	27.8
METAL GAUGES	BLOWER SECTION	Frame	16	16	16	16	16	16	16
		Non Insulated Panels	16	16	16	16	16	16	16
		Insulated Panels	20	20	20	20	20	20	20
		Base	12	12	12	12	12	12	12
MOTORS	MINIMUM HP		1/3	1/3	1/2	3/4	3/4	3/4	3/4
	MAXIMUM FRAME SIZE		184T	213T	215T	254T	256T	284T	284T

N/A = Not Available

**NOTES:**

- Correction Factors for Other Refrigerants - Use **R404A** Values Multiplied By

<b>R407C</b>	<b>R22</b>	<b>R134a</b>	<b>R507</b>	<b>R410A</b>
1.10	1.15	1.11	1.00	1.02

- Charge does not include any headers.

DESCRIPTION		UNIT SIZE							
		122	128	137	141	150	164	182	
HEATING		6000-19000	8000-25000	10000-32000	12000-32000	15000-39000	18000-50000	25000-64000	
STANDARD FAN DATA	FORWARD CURVED	Outlet Area - Square Feet	4.38	5.5	6.9	8.67	10.91	13.74	17.27
		Number - Diameter (in) - Type	1 - 20 FC	1 - 22 FC	1 - 25 FC	1 - 28 FC	1 - 32 FC	1 - 36 FC	1 - 40 FC
		Shaft and Bearing Size (in)	1 11/16	2	2 7/16	2 7/16	2 3/16	2 7/16	2 7/16
OPTIONAL FAN DATA	AIRFOIL	Outlet Area - Square Feet	4.38	5.5	6.9	8.67	10.91	13.74	17.27
		Number - Diameter (in) - Type	1 - 20 AF	1 - 22 AF	1 - 25 AF	1 - 28 AF	1 - 32 AF	1 - 36 AF	1 - 40 AF
		Shaft and Bearing Size (in)	1 11/16	2	2	2 3/16	2 3/16	2 7/16	2 7/16
COIL DATA	Number - Size (in)		39 x 92	39 x 116	51 x 116	60 x 116	69 x 116	87 x 116	87 x 153
	Face Area - Square Feet		24.92	31.42	41.08	48.33	55.58	70.08	92.44
	Number of Face Tubes		26	26	34	40	46	58	58
	STANDARD 6 ROW COIL: Normal Refrigerant Operating Charge (lbs.) see notes below		28.7	36	47.1	55.4	63.7	80.3	105.4
FILTER DATA	2" FLAT FILTER SECTION	Number - Size (in)	12 - 16x20x2	12 - 20x20x2	12 - 20x25x2	18 - 20x20x2	12 - 20x25x2 6 - 20x20x2	6 - 20x25x2 18 - 20x20x2	8 - 20 X 25 24 - 20 X 20
		Filter Area - Square Feet	26.7	33.4	41.6	50.2	58.4	70.6	90
	4" FLAT FILTER SECTION	Number - Size (in)	12 - 16x20x4	12 - 20x20x4	12 - 20x25x4	18 - 20x20x4	12 - 20x25x4 6 - 20x20x4	6 - 20x25x4 18 - 20x20x4	8 - 20 X 25 24 - 20 X 20
		Filter Area - Square Feet	26.7	33.4	41.6	50.2	58.4	70.6	90
	2" ANGULAR FILTER SECTION	Number - Size (in)	16 - 16x25x2	12 - 20x25x2	16 - 20x25x2	24 - 20x20x2	24 - 20x25x2	30 - 20x25x2	8 - 20X20X2 32 - 20X25X2
		Filter Area - Square Feet	33.4	41.8	55.5	66.7	83.2	104	133
METAL GAUGES	BLOWER SECTION	Frame	16	16	16	16	16	16	16
		Non Insulated Panels	16	16	16	16	16	16	16
		Insulated Panels	20	20	20	20	20	20	20
		Base	12	12	10	10	10	10	10
MOTORS	MINIMUM HP		1	1-1/2	1-1/2	1-1/2	1-1/2	3	5
	MAXIMUM FRAME SIZE		324T	324T	364T	365T	365T	365T	405T

N/A = Not Available

**NOTES:**

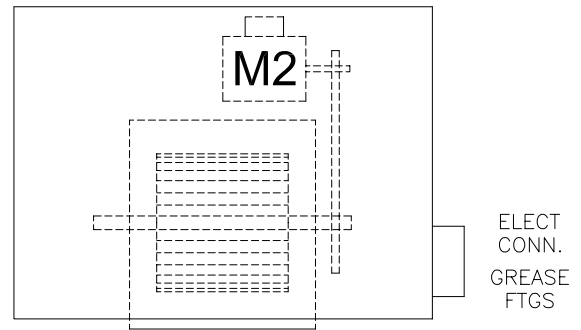
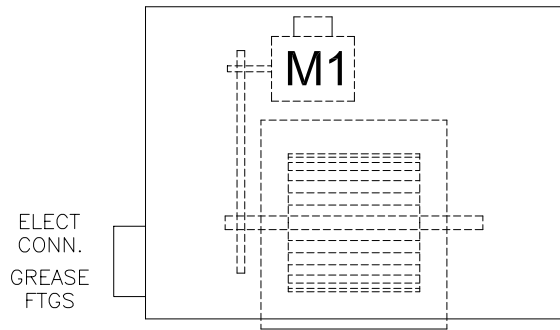
- Correction Factors for Other Refrigerants - Use **R404A** Values Multiplied By

R407C	R22	R134a	R507	R410A
1.10	1.15	1.11	1.00	1.02

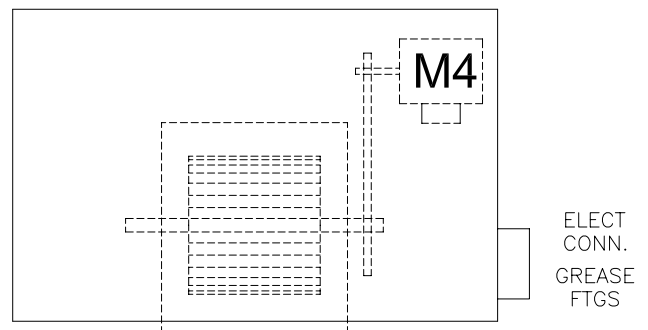
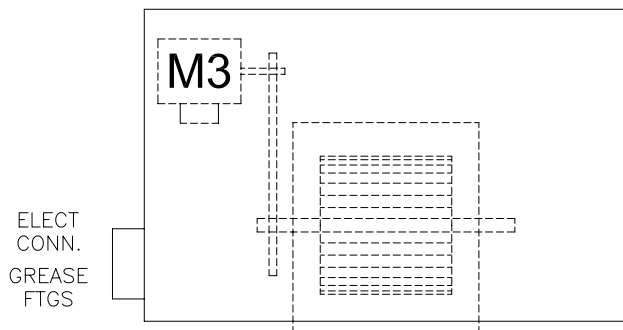
- Charge does not include any headers.

## TOP VIEWS

### MOTOR LOCATIONS M1 & M2 FOR MODELS 103 THRU 128 ONLY



### MOTOR LOCATIONS M3 & M4 FOR MODELS 137 THRU 182 ONLY



LOCATIONS ARE TYPICAL FOR ALL  
AIR FLOW CONFIGURATIONS

#### MOTOR CONSTRUCTION ARRANGEMENT

M1 LOCATION, - F1

M2 LOCATION, - F2

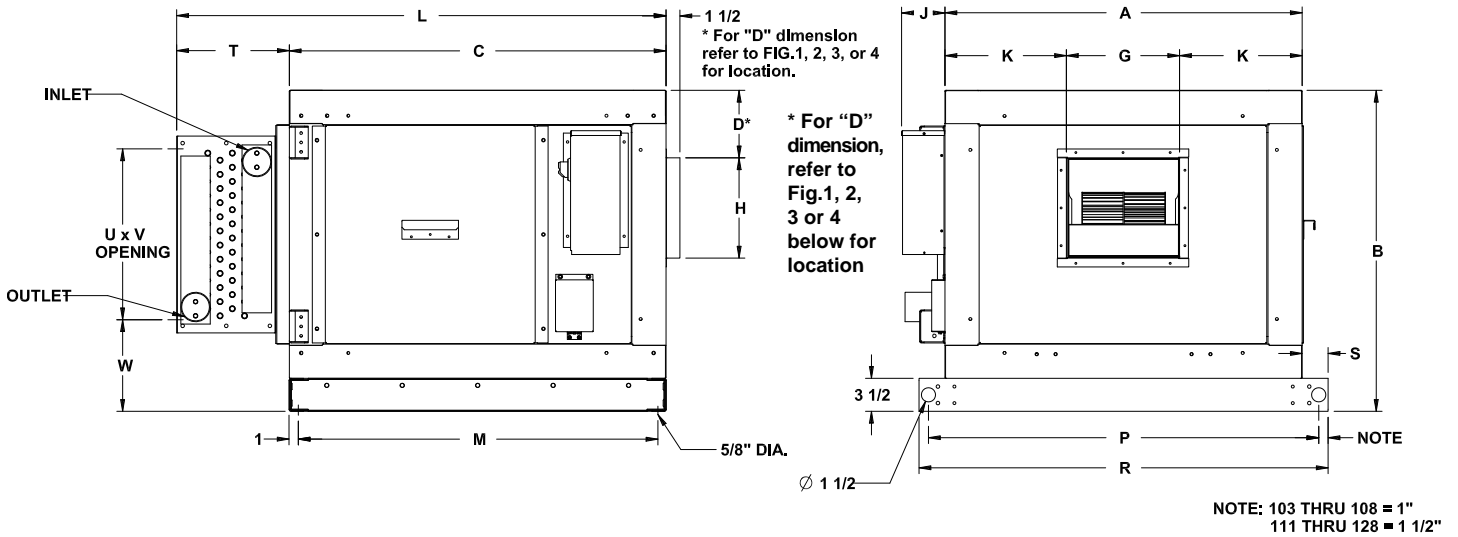
M3 LOCATION, - F1

M4 LOCATION, - F2

SEE MOTOR PART NUMBERS IN ELECTRICAL DATA TABLES

#### DRIVE INSTALLATION

- A. All motors are mounted on a heavy duty slide base located inside the cabinet.
- B. Drives are pre-set for desired RPM.
- C. Belt tension is factory set.



## DIMENSIONS - IMPERIAL (inches)

UNIT SIZE	A	B	C	FIG. #1 D*	FIG. #2 D*	FIG. #3/4 D*	G	H	J	K	M	P	R	S	T	U	V	W
103	37 7/8	34	40	7 1/8	11 1/2	10 3/8	12 1/8	10 3/4	4 1/2	12 7/8	38	41 3/8	43 3/8	2 3/4	see table below	18	30	9 3/4
104	43 7/8	37	45 1/8	8 1/8	13 3/8	11 7/16	13 1/4	11 5/8	4 1/2	15 5/16	43 1/8	47 3/8	49 3/8	2 3/4		21	36	9 3/4
106	53 7/8	40 1/2	47	8 7/16	14 3/4	12 7/16	15 7/8	13 3/4	4 1/2	19	45	57 3/8	59 3/8	2 3/4		24	45	10
108	51 7/8	48	53 9/16	12 1/4	19 7/8	6 3/16	19	16 1/4	4 3/4	16 7/16	51 9/16	55 3/8	57 3/8	2 3/4		33	44	9 1/4
111	66 7/8	48	63 1/8	7 1/2	17 1/8	7 1/4	22 1/4	19 1/4	4 3/4	22 5/16	61 1/8	69 3/4	72 3/4	2 15/16		33	58	9 1/4
114	81 7/8	48	63 1/8	7 1/2	17 1/8	7 1/2	22 1/4	19 1/4	4 3/4	29 13/16	61 1/8	84 3/4	87 3/4	2 15/16		33	74	9 1/4
117	96 7/8	48	63 1/8	6 7/8	16 1/2	7 1/8	22 1/4	19 1/4	4 3/4	37 5/16	61 1/8	99 3/4	102 3/4	2 15/16		33	88	9 1/4
122	100 7/8	54	69 1/8	6 1/2	17 1/2	6 1/2	25 3/8	25 3/8	4 3/4	37 3/4	67 1/8	103 3/4	106 3/4	2 15/16		39	92	8 3/4
128	123 7/8	57	73 1/8	5 1/4	17	6 3/4	28 1/4	28 1/4	4 3/4	47 13/16	71 1/8	126 3/4	129 3/4	2 15/16		39	116	10 1/4

UNIT SIZE	T	T	T	T	T	T
	6 1/2 2 ROW L	7 1/2 3 ROW L	9 4 ROW L	12 6 ROW L	15 8 ROW L	18 10 ROW L
103	46 1/2	47 1/2	49	52	55	58
104	51 5/8	52 5/8	54 1/8	57 1/8	60 1/8	63 1/8
106	53 1/2	54 1/2	56	59	62	65
108	60 1/8	61 1/8	62 5/8	65 5/8	68 5/8	71 5/8
111	69 5/8	70 5/8	72 1/8	75 1/8	78 1/8	81 1/8
114	69 5/8	70 5/8	72 1/8	75 1/8	78 1/8	81 1/8
117	69 5/8	70 5/8	72 1/8	75 1/8	78 1/8	81 1/8
122	75 5/8	76 5/8	78 1/8	81 1/8	84 1/8	87 1/8
128	79 5/8	80 5/8	82 1/8	85 1/8	88 1/8	91 1/8

NOTE: All dimensions are approximate. Certified drawings available on request.

### \* NOTE: "D" DIMENSION VARIES BASED ON AIRFLOW CONFIGURATION

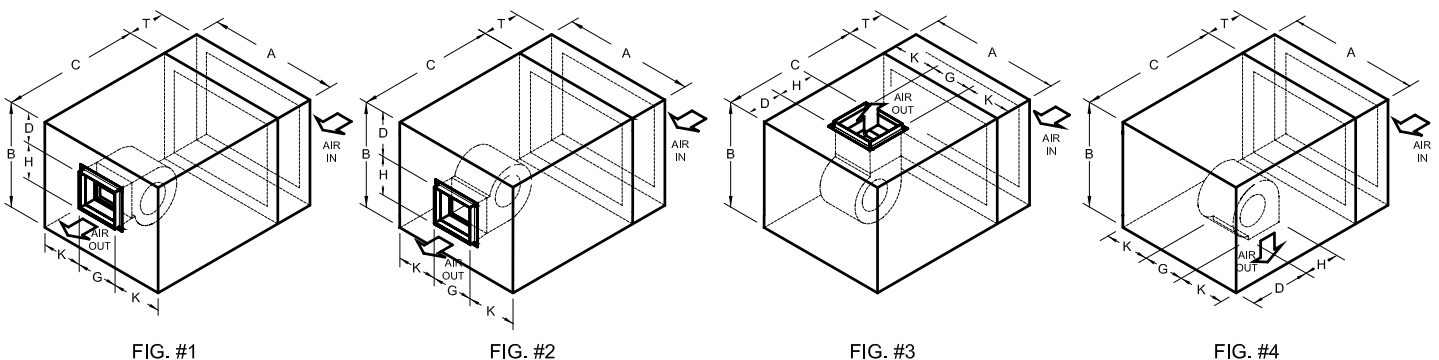
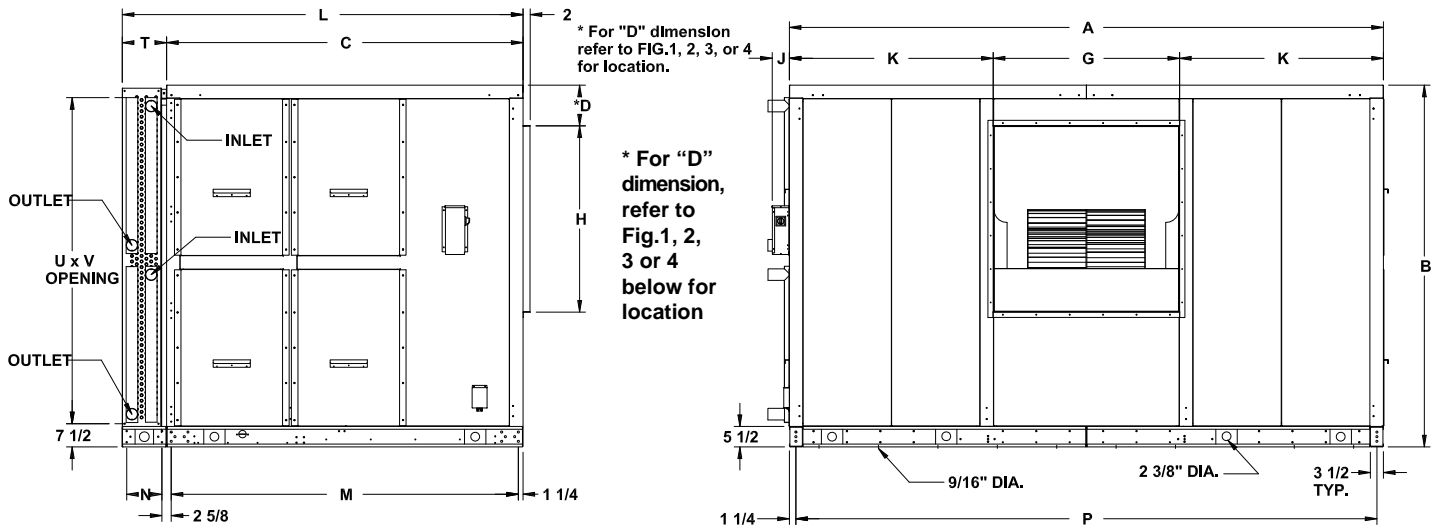


FIG. #1

FIG. #2

FIG. #3

FIG. #4



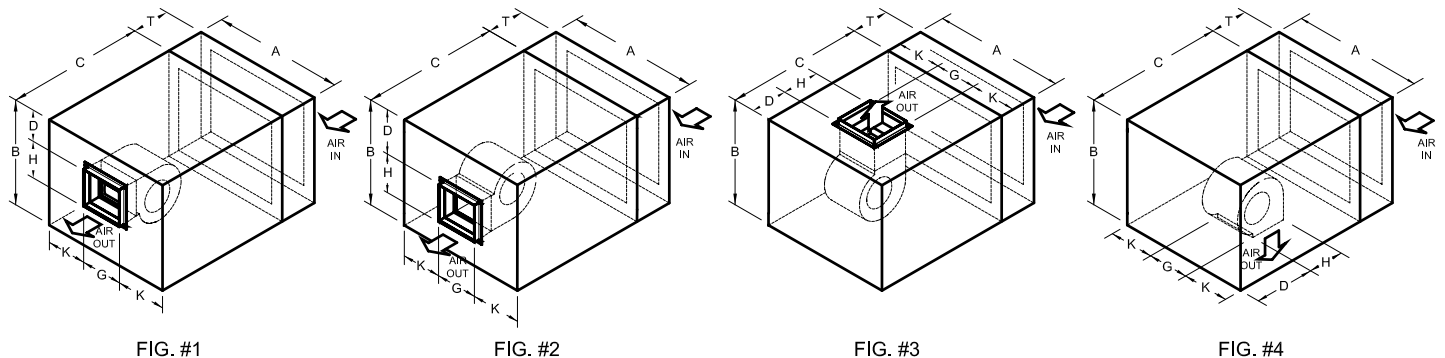
### DIMENSIONS - IMPERIAL (inches)

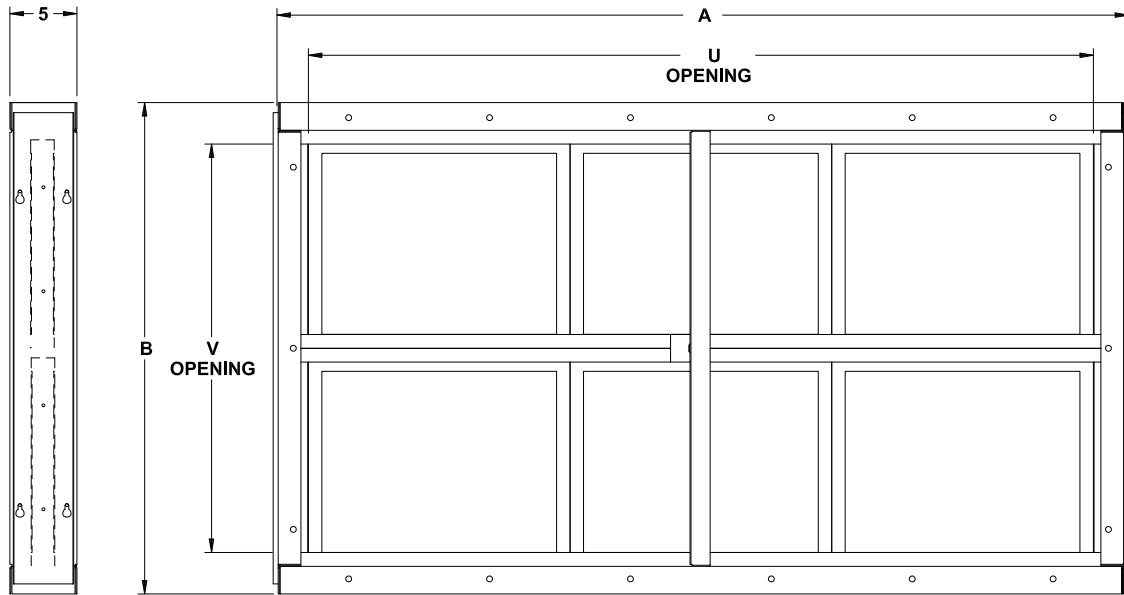
UNIT SIZE	A	B	C	FIG. #1 D*	FIG. #2 D*	FIG. #3/4 D*	G	H	J	K	M	P	T	U	V
137	130	61 1/2	70	5 3/4	17 7/8	15 7/8	31 3/4	31 3/4	4 3/4	49 1/8	67 1/2	127 1/2	see table below	51	116
141	130	70 1/2	75	6	20 1/4	17 7/8	35 5/8	35 5/8	4 3/4	47 3/16	72 1/2	127 1/2		60	116
150	130	79 1/2	82	10 1/4	27 7/8	19 3/4	40	40	4 3/4	45	79 1/2	127 1/2		69	116
164	130	97 1/2	90	21 1/4	40 7/8	23 1/4	44 3/4	44 3/4	5 3/4	42 5/8	87 1/2	127 1/2		87	116
182	160	97 1/2	96	10 7/8	31 5/8	23 1/2	50 1/4	50 1/4	5 3/4	54 7/8	93 1/2	157 1/2		87	153

UNIT SIZE	T	T	T	T	T	T
	6 1/2 2 ROW L	7 1/2 3 ROW L	9 4 ROW L	12 6 ROW L	15 8 ROW L	18 10 ROW L
137	76 1/2	77 1/2	79	82	85	88
141	81 1/2	82 1/2	84	87	90	93
150	78 1/2	79 1/2	81	84	87	90
164	96 1/2	97 1/2	99	102	105	108
182	102 1/2	103 1/2	105	108	111	114

NOTE: All dimensions are approximate. Certified drawings available on request.

### \* NOTE: "D" DIMENSION VARIES BASED ON AIRFLOW CONFIGURATION





**\* AVAILABLE WITH 2" FILTERS ONLY**

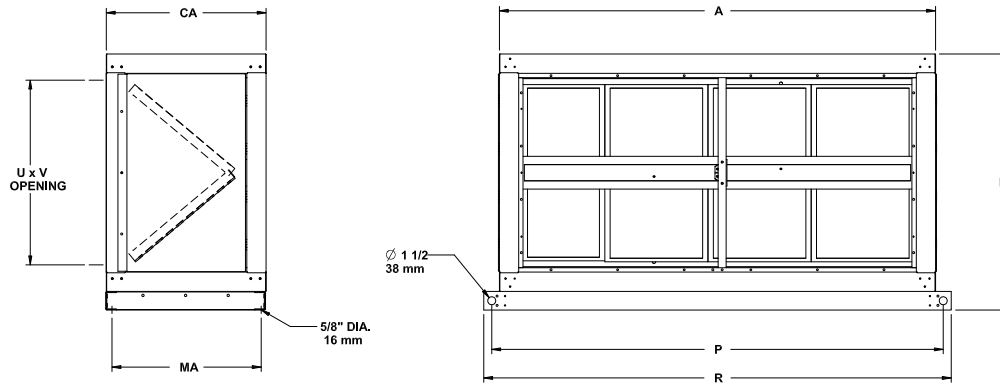
### DIMENSIONS - IMPERIAL (inches)

UNIT SIZE	A	B	INLET OPENING	
			U	V
103	34	21 5/8	30 5/8	17 5/8
104	40	24 5/8	36 5/8	20
106	50	27 5/8	46 5/8	23 1/8
108	48	36 5/8	44 5/8	32 1/2
111	63	36 5/8	59 5/8	32 1/2
114	78	36 5/8	74 5/8	32 1/2
117	93	36 5/8	89 5/8	32 1/2
122	97	43 5/8	93 5/8	40 1/8
128	120	43 5/8	116 5/8	40 1/8
137	119 3/8	55 1/8	116 5/8	50 1/8
141	119 3/8	63 3/8	116 5/8	60 1/8
150	119 3/8	73 1/8	116 5/8	70 1/8
164	119 3/8	91 1/8	116 5/8	85 1/4
182	149 3/8	91 1/8	146 5/8	85 1/4

**NOTE:** All dimensions are approximate. Certified drawings available on request.



**Note: Optional Duct Extension Flanges (1-1/2) available.**



Note:  
Models 114 through 128 have 12GA. "C" rails extended as shown.  
Curb mount capability.  
See Mounting Hole Locations on Page 18

Note:  
Models 137 through 182 have 10GA frame structure flush with cabinet.

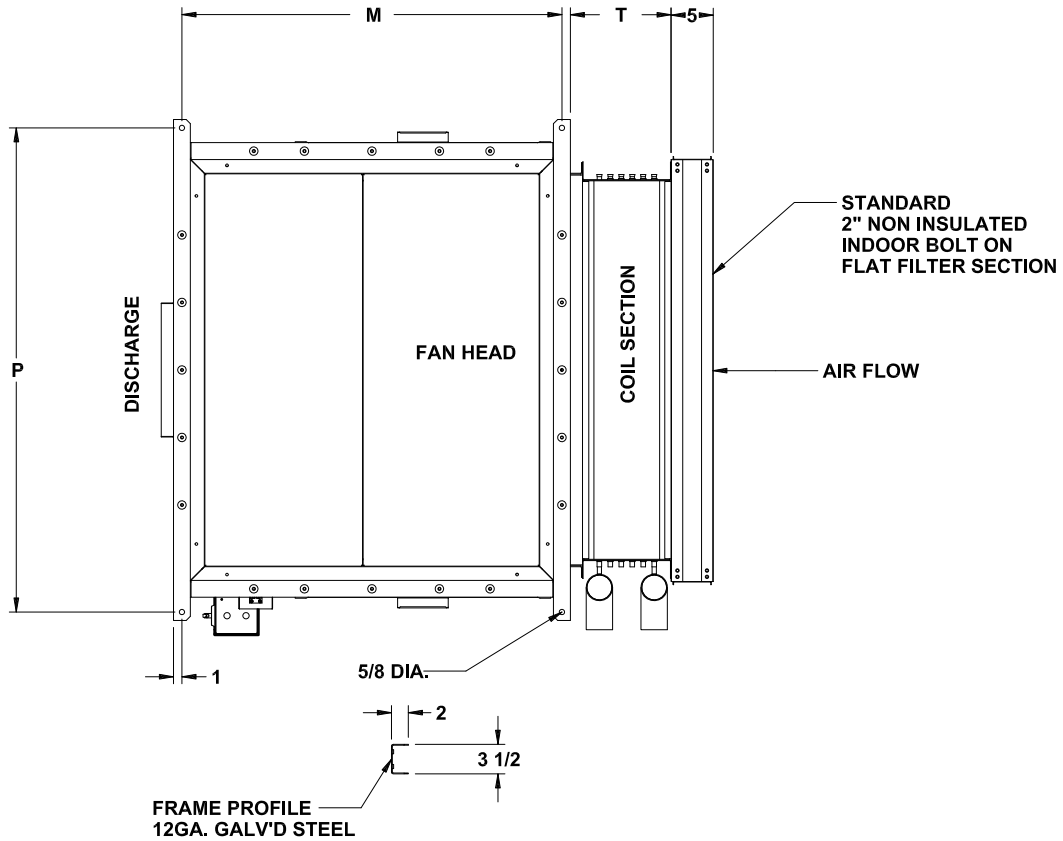
## DIMENSIONS - IMPERIAL (inches)

UNIT SIZE	STANDARD WIDTH			STANDARD HEIGHT	ANGULAR FILTER LENGTH		INLET OPENING	
	A	P	R		B	CA	MA	U
114	81 7/8	84 3/4	87 3/4	48	30	28	35 11/16	73
117	96 7/8	99 3/4	102 3/4	48	30	28	35 11/16	88
122	100 7/8	103 3/4	106 3/4	54	30	28	41 11/16	90 1/2
128	123 7/8	126 3/4	129 3/4	57	30	28	44 11/16	115
137	130	-	130	61 1/2	30	28	55 3/4	121 1/8
141	130	-	130	76 1/8	30	28	61 3/4	121 1/8
150	130	-	130	79 1/4	30	28	74	121 1/8
164	130	-	130	97 1/2	35	33	86 1/2	121 1/8
182	160		160	97 1/2	35	33	86 1/2	151 1/8

**NOTE:** All dimensions are approximate. Certified drawings available on request.

### Models 103-128

#### BOTTOM VIEW



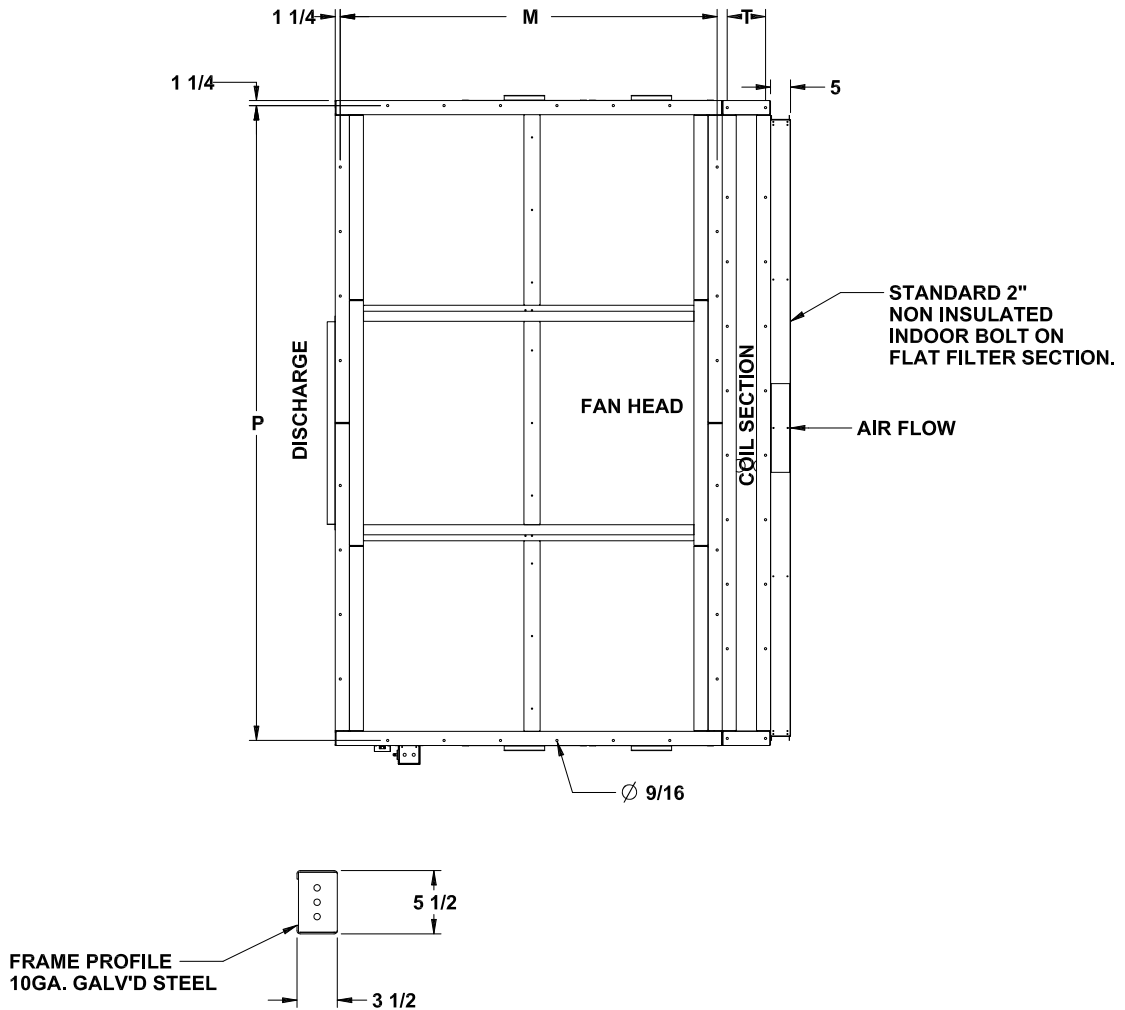
#### DIMENSIONS - IMPERIAL (inches)

MODEL	STANDARD WIDTH	FAN HEAD	2 ROW	3 ROW	4 ROW	6 ROW	8 ROW	10 ROW
	P	M	T	T	T	T	T	T
103	41 3/8	38	6 1/2	7 1/2	9	12	15	18
104	47 3/8	43 1/8	6 1/2	7 1/2	9	12	15	18
106	57 3/8	45	6 1/2	7 1/2	9	12	15	18
108	55 3/8	51 9/16	6 1/2	7 1/2	9	12	15	18
111	69 3/4	61 1/8	6 1/2	7 1/2	9	12	15	18
114	81 3/4	61 1/8	6 1/2	7 1/2	9	12	15	18
117	99 3/4	61 1/8	6 1/2	7 1/2	9	12	15	18
122	103 3/4	67 1/8	6 1/2	7 1/2	9	12	15	18
128	126 3/4	71 1/8	6 1/2	7 1/2	9	12	15	18

NOTE: All dimensions are approximate. Certified drawings available on request.

### Models 137-182

#### BOTTOM VIEW



#### DIMENSIONS - IMPERIAL (inches)

MODEL	STANDARD WIDTH	FAN HEAD	2 ROW	3 ROW	4 ROW	6 ROW	8 ROW	10 ROW
	P	M	T	T	T	T	T	T
137	127 1/2	67 1/2	6 1/2	7 1/2	9	12	15	18
141	127 1/2	72 1/2	6 1/2	7 1/2	9	12	15	18
150	127 1/2	79 1/2	6 1/2	7 1/2	9	12	15	18
164	127 1/2	87 1/2	6 1/2	7 1/2	9	12	15	18
182	157 1/2	93 1/2	6 1/2	7 1/2	9	12	15	18

**NOTE:** All dimensions are approximate. Certified drawings available on request.

**GENERAL**

Furnish and install where shown on plans, Type AB Air Handling Units with Bolt-on type coils. Sizes and performance shall be as indicated in the Unit Schedule. Each unit shall be complete with factory furnished components as shown on the plans.

Cabinets shall be of sectionalized construction, and all sheet metal parts including accessories shall be fabricated of continuous galvanized steel. The casing panels shall be removable for easy access to the interior of the unit. AB units shall be single wall and no insulation unless otherwise specified (Optional double wall and insulated with 2" mineral wool).

**FAN ASSEMBLY**

Fans shall be forward curved and designed for Class II operation. Fan ratings shall be based on fan tests conducted in accordance with AMCA Code No. 210. Fan housings and wheels shall be continuous galvanized steel. All fan wheels shall be keyed to the fan shaft.

**BEARINGS AND FAN SHAFT**

The fan shaft shall be solid high carbon steel, fully sized throughout. The maximum rated fan RPM shall be well below the first critical fan shaft speed.

Bearing shall be self-aligning, grease lubricated, ball type (9-9 T2 through 28-28 T2) in pillow block cast iron housings, roller type (32-32 T2 through 40-40 T2) in pillow block split cast iron housings. Lubrication fittings shall be provided, and permanently lubricated bearings will be unacceptable.

**COILS - GENERAL**

Coils shall be constructed with 1/2" O.D. or 5/8" O.D. copper tubes and (aluminum) (copper) rippled-corrugated fins. Tubes shall be arranged in a staggered tube pattern with respect to air flow. Fins shall have full drawn collars to provide a continuous secondary surface cover over the entire tube length. Tubes shall be expanded into fins to provide a continuous primary to secondary compression contact over the entire finned length.

Coil casing shall be of continuous galvanized steel. Coil face velocity shall be as indicated on the unit schedule. The rows of coil shall be as required to produce the capacities as indicated in the performance schedule. All water coils shall be circulated to obtain optimum tube water velocity. No devices shall be used inside the coil tubes which interfere with the drainability or increase water pressure drop. Depending on applications, coils shall be tested with 300, 450 or 650 PSIG air under water.

**CONDENSER / HEAT RECLAIM COILS**

Coils shall be constructed with 1/2" O.D. or 5/8" O.D. copper tubes and aluminum (copper) rippled-corrugated fins. Any number of coil circuits shall be available provided the total does not exceed the number of tubes in the coil face. Coils shall be provided with sweat-type connections and shall be circuited for proper refrigerant drainage.

**WATER HEATING COILS**

Coils shall be constructed with 5/8" O.D. copper tubes and aluminum (copper) rippled-corrugated fins. Coils shall be designed for use with heated water or glycol mixture. With a vent connection at the highest point, and a drain connection at the lowest point. Headers shall be fabricated of copper tubes, and the connections shall be male pipe threaded with protective caps. Water heating coils shall be furnished as indicated on the Unit Schedule.

**FILTER SECTION**

Furnish factory built (flat) (angular) filter section complete with filters as specified herein. The filter area shall be as specified on the Unit Schedule. (Flat and Angular filter sections shall have access doors on both ends.)

**FILTERS**

Filters shall be (throwaway) (permanent) (permanent high velocity) type.

## GENERAL

- A. The items should be carefully checked against the bills of lading to be sure all crates and cartons have been received. All units should be carefully inspected for damage when received. Visible or concealed damage should be reported immediately to the carrier and a claim filed for damage.
- B. Air Handler units are constructed of heavy gauge galvanized steel and are thoroughly inspected before leaving the plant. Care must be taken during installation to prevent damage to units.
- C. In order to insure long and trouble-free life, the units should have proper care and maintenance. Enough space should be left around the unit for filter removal, lubrication, and removal of coils if this should become necessary.
- D. Flexible connections should be used on the outlet connections and oil inlet duct connections of the unit.
- E. Special care should be taken when handling the blower section. All fans are dynamically balanced before leaving the plant. Rough handling, however, can cause misalignment of the drives. Sheaves should be carefully inspected before unit installation to make sure this has not happened.
- F. Screws, bolts, etc., for assembly of sections are supplied in a cloth bag attached to each section. Gasketing to be used between sections, when assembling, is supplied in rolls in the unit.

Some units are shipped in sections and must be assembled on the job.

### A. HANDLING OF SECTIONS:

- 1. Lifting / Isolator rails are supplied for bottom lifting only. Models 103 thru 128.
- 2. Lifting rails are supplied with 5/8" dia. Holes, suitable for 1/2" rod.
- 3. If units are to be moved using just one hoist, a spreader bar should be used to prevent damage to the unit.
- 4. Models 137 thru 182 come with lifting gussets located in the base frame. Fig.6

### B. GASKETING:

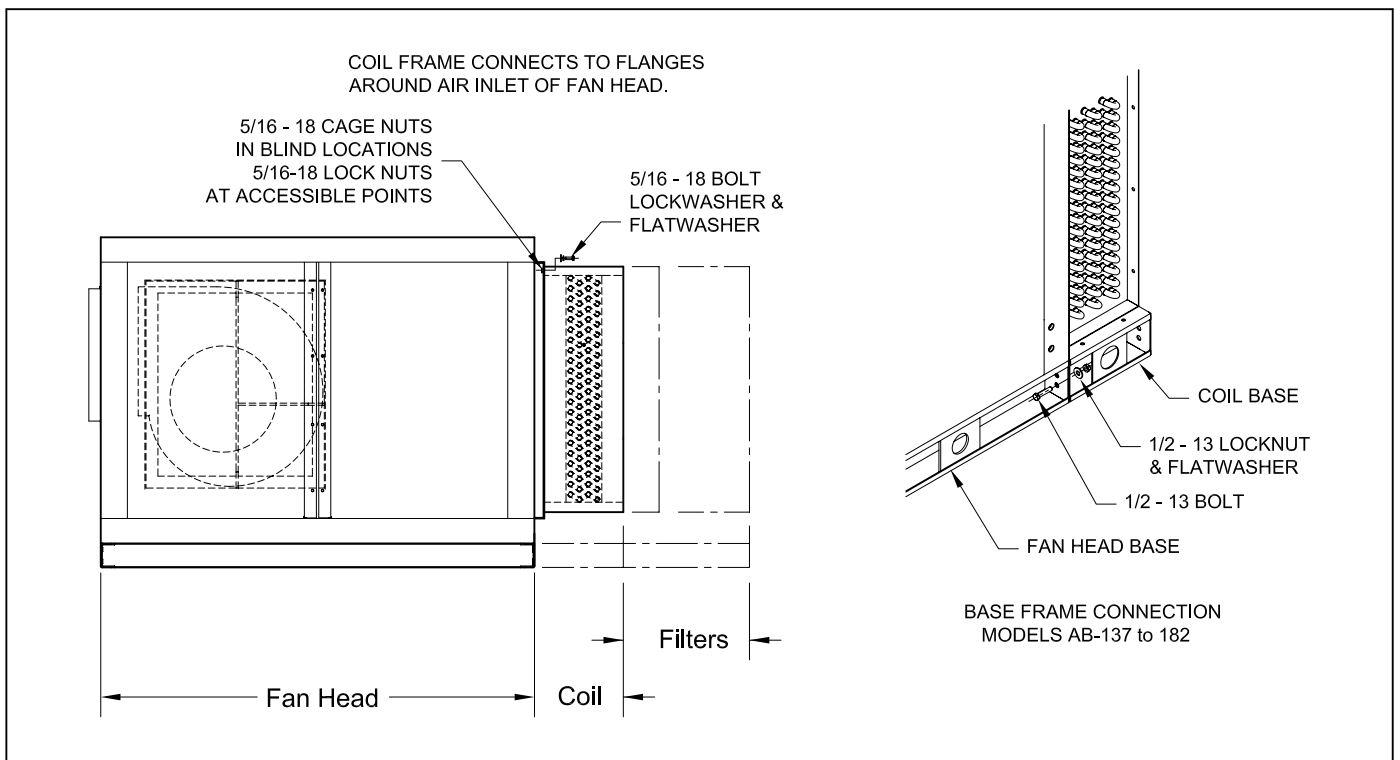
The gasketing is supplied with each section that has to be assembled on the job.

- 1. Gasket the perimeter of the section when necessary. Join ends tight to avoid air leakage. Fig. 2 & 3

### C. FASTENING OF SECTIONS:

- 1. Figure 1 shows the typical attaching method used for fan head and heating and ventilating coil sections.
  - a. Gasket the perimeter of the coil section flange as outlined in "Gasketing". Fig. 2 & 3
  - b. Align the sections using the mounting brackets as shown in Fig.1.
  - c. Bolt the base frame as shown in Fig.1.

**Figure 1**  
**TYPICAL ATTACHING METHOD**

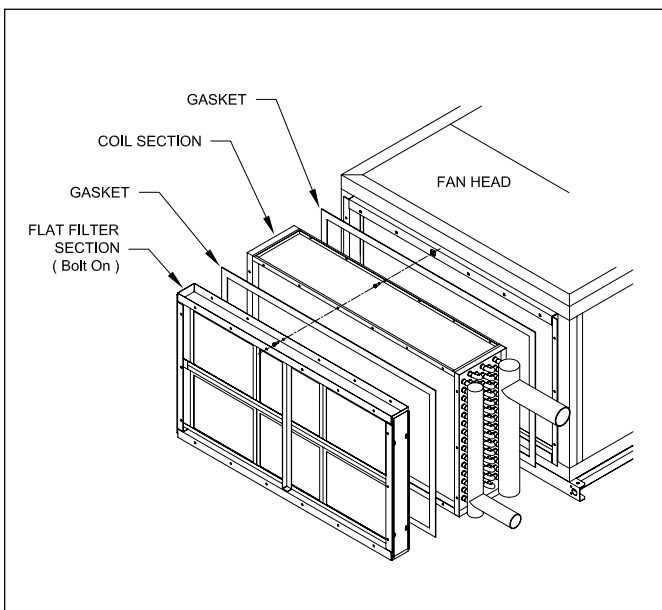


## GENERAL (cont'd)

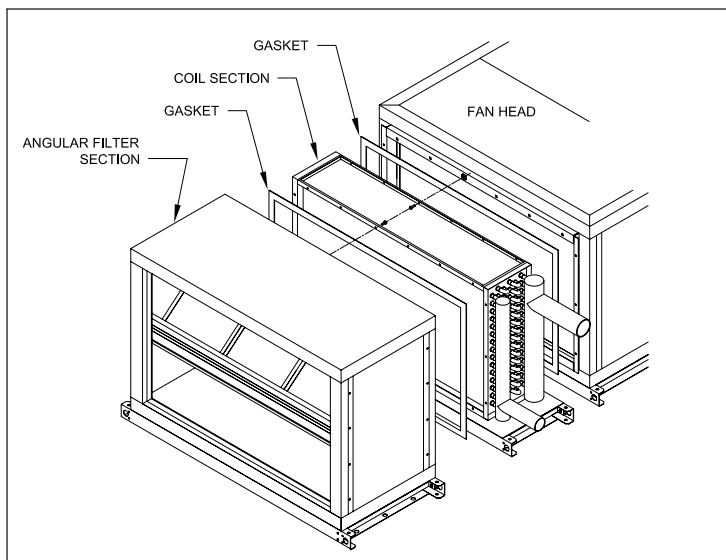
### D. MOUNTING OF SECTION

1. All models are to be moved into position using the bottom lifting rails (103 thru 128) or the base frame (137 thru 182). No units are to be lifted from the top.
2. When crane lifting, proper spreader bars should be used to avoid damage to the cabinet material. See Fig.4, 5, & 6.

**Figure 2  
FLAT FILTER to COIL (Bolt-on Style)  
ALL MODELS**



**Figure 3  
ANGULAR FILTER to COIL  
ALL MODELS**



## LOCATING AND INSTALLATION HINTS

**IMPORTANT: Product Coolers AB137, AB141, AB150, AB164 and AB182 MUST be platform or floor mounted.**

## DRIVE INSTALLATION

- A. All motors are mounted on a heavy duty slide base located inside the cabinet.
- B. Drives are pre-set for desired RPM.
- C. Belt tension is factory set.

## UNIT INSTALLATION

- A. Units 103 thru 128 come complete with lifting rails with 5/8" dia. mounting holes. Lifting rails are also designed to mount to roof curbs supplied by others. Lifting rails also allow for ceiling suspension with isolators – holes to allow 1/2 rod.
- B. Units 137 thru 182 come complete with 5-1/2" "C" channel designed for bottom mounting only.

**IMPORTANT**  
Models TAB137 through 182  
are suitable for bottom mounting only.  
In order to suspend equipment  
from the ceiling, a field installed supporting  
structure must be provided

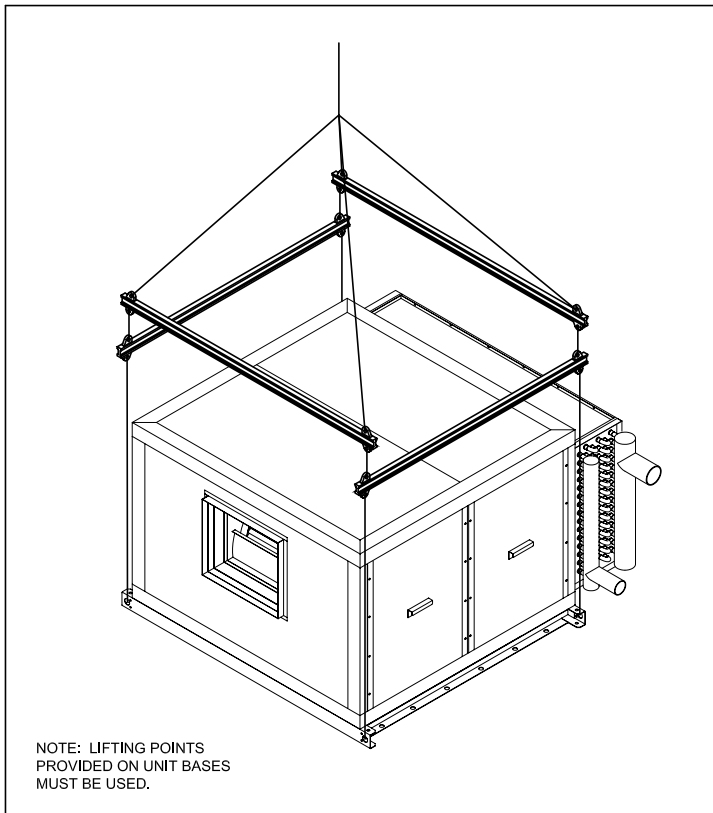
## LIFTING INSTRUCTIONS

Air handling units and associated sections are large, heavy, mechanical equipment and must be handled as such. A fully qualified and properly crew with necessary rigging should be engaged to set the components into position. Lifting holes have been provided along base frames for attaching lifting slings. Spreader bars must be used so that lifting forces are applied vertically.

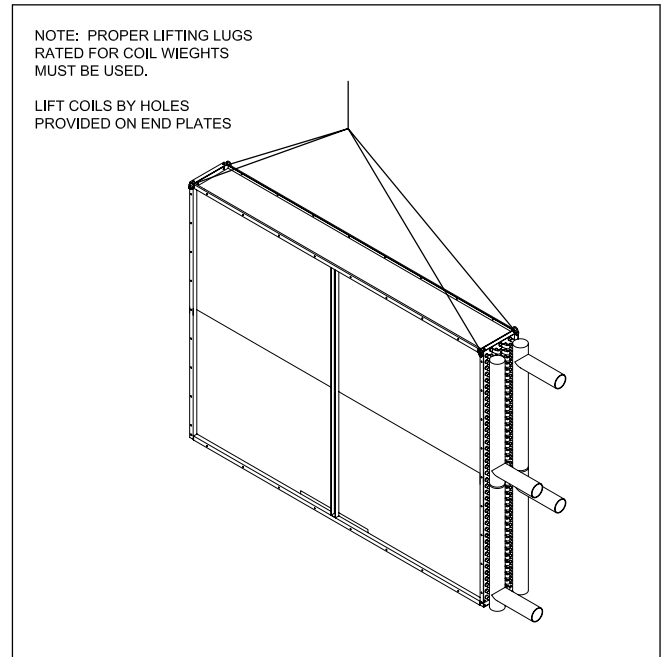
### Note:

- Coil sections, if shipped separately, will have base frames installed.
- Lifting lugs are provided on unit base rails
- Ensure that unit top side is stabilized to prevent tipping when lifting sections into place.
- Under no circumstances should coil connections, drains or weather covers be used for lifting.
- Base frames must be securely anchored to the building structure, sleeper, roof curb or concrete pad.
- the weight of the air handling unit and accessory sections alone is not enough to hold in place

**Figure 4**  
**FAN HEAD and ASSEMBLED SECTIONS -**  
**Models AB103 - 128**

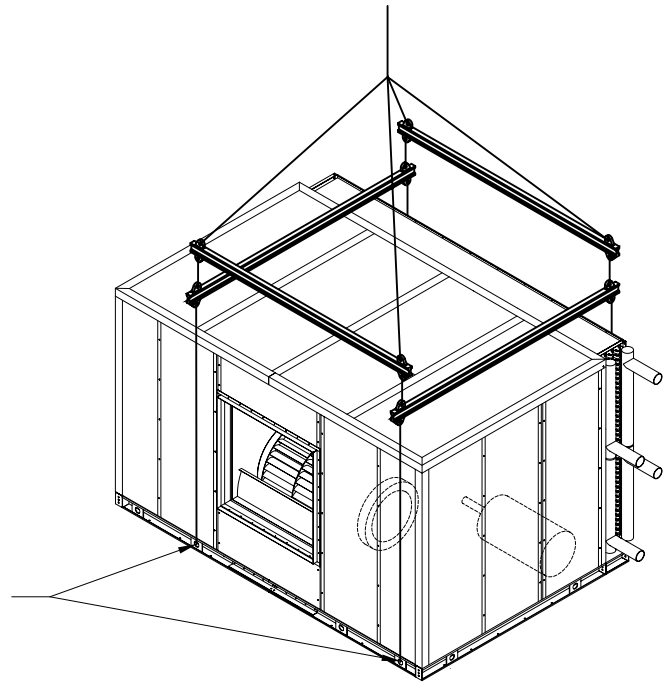


**Figure 5**  
**COILS MAY BE SHIPPED SEPARATELY**



**Figure 6**  
**FAN HEAD and ASSEMBLED SECTIONS**  
**Models AB137 - 182**

On models 137 through 182, motor and drive sizes can greatly off-set the unit centre of gravity. Welded lugs are positioned in base channels to provide available points for lifting units vertically. Care must be taken to locate motor position in unit before determining appropriate lifting points.





## TYPICAL AIR HANDLING UNIT WIRING DIAGRAMS - 1800 RPM

115 / 230 VOLT, 1 PHASE ( 1/3 TO 2 HP )	230 / 460 VOLT, 3 PHASE ( 9 LEAD MOTOR - 1/3 TO 5 HP )	230 / 460 VOLT, 3 PHASE ( 12 LEAD MOTOR - 3 WIRE )	230 / 460 VOLT, 3 PHASE ( 12 LEAD MOTOR - 6 WIRE )	575 VOLT, 3 PHASE														
<p>REFER TO DATAPLATE FOR ELECTRICAL REQUIREMENTS.</p> <p><b>115V WIRING</b> BLOWER MOTOR WITH MANUAL INTERNAL OVERLOAD</p> <p><b>230V WIRING</b> BLOWER MOTOR WITH MANUAL INTERNAL OVERLOAD ROTATION "CW-OPE" TO REVERSE EITHER VOLTAGE INTERCHANGE RED &amp; BLACK LEADS</p>	<p>REFER TO DATAPLATE FOR ELECTRICAL REQUIREMENTS.</p> <p><b>230V WIRING USING WYE-WYE MOTOR LEADS</b> BLOWER MOTOR (NO INTERNAL OVERLOAD) REQUIRES EXTERNAL OVERLOAD (BY OTHERS)</p> <p><b>460V WIRING USING WYE MOTOR LEADS</b> BLOWER MOTOR (NO INTERNAL OVERLOAD) REQUIRES EXTERNAL OVERLOAD (BY OTHERS)</p>	<p>REFER TO DATAPLATE FOR ELECTRICAL REQUIREMENTS.</p> <p><b>230V WIRING USING DELTA-DELTA MOTOR LEADS</b> BLOWER MOTOR (NO INTERNAL OVERLOAD) REQUIRES EXTERNAL OVERLOAD (BY OTHERS)</p> <p><b>460V WIRING USING DELTA MOTOR LEADS</b> BLOWER MOTOR (NO INTERNAL OVERLOAD) REQUIRES EXTERNAL OVERLOAD (BY OTHERS)</p>	<p>REFER TO DATAPLATE FOR ELECTRICAL REQUIREMENTS.</p> <p><b>230V WIRING USING DELTA-DELTA MOTOR LEADS</b> BLOWER MOTOR (NO INTERNAL OVERLOAD) REQUIRES EXTERNAL OVERLOAD (BY OTHERS)</p> <p><b>460V WIRING USING DELTA MOTOR LEADS</b> BLOWER MOTOR (NO INTERNAL OVERLOAD) REQUIRES EXTERNAL OVERLOAD (BY OTHERS)</p> <p><b>75 &amp; 100 HP</b> NOTE: TWO WIRES (EQUAL GAUGE AND LENGTH) USED AS SINGLE CONDUCTOR.</p>	<p>REFER TO DATAPLATE FOR ELECTRICAL REQUIREMENTS.</p> <p><b>575V WIRING USING WYE MOTOR LEADS</b> BLOWER MOTOR (NO INTERNAL OVERLOAD) REQUIRES EXTERNAL OVERLOAD (BY OTHERS)</p> <p><b>6 LEAD MOTOR ( 7-1/2 TO 100 HP )</b> <b>575V WIRING USING DELTA MOTOR LEADS</b> BLOWER MOTOR (NO INTERNAL OVERLOAD) REQUIRES EXTERNAL OVERLOAD (BY OTHERS)</p>														
<p>1. USE COPPER CONDUCTORS ONLY 2. USE 75°C WIRE (OR HIGHER) 3. OPTIONAL COMPONENTS -FACTORY OR INSTALLED BY OTHERS</p> <p>4. CONDUCTORS / WIRING            ————— FACTORY WIRING            - - - - - WIRING BY OTHERS            - - - - - OPTIONAL COMPONENT FACTORY WIRING</p> <p>5. ALL FIELD WIRING MUST BE DONE IN COMPLIANCE WITH ALL APPLICABLE LOCAL AND NATIONAL CODES.</p>																		
			<table border="1" style="width:100%; border-collapse: collapse;"> <thead> <tr> <th colspan="2">REVISIONS</th> <th>DIAGRAM NUMBER</th> </tr> <tr> <th>DATE</th> <th>LTR</th> <th></th> </tr> </thead> <tbody> <tr> <td>-</td> <td>-</td> <td rowspan="3">1099106-TYPICAL</td> </tr> <tr> <td>-</td> <td>-</td> </tr> <tr> <td>-</td> <td>-</td> <td>MAR. 28/14</td> </tr> </tbody> </table>		REVISIONS		DIAGRAM NUMBER	DATE	LTR		-	-	1099106-TYPICAL	-	-	-	-	MAR. 28/14
REVISIONS		DIAGRAM NUMBER																
DATE	LTR																	
-	-	1099106-TYPICAL																
-	-																	
-	-		MAR. 28/14															

**ALL 1 PHASE MOTORS c/w  
MANUAL THERMAL OVERLOAD**

**ALL 3 PHASE MOTORS ARE NOT INTERNALLY OVERLOAD PROTECTED.  
EXTERNAL MOTOR OVERLOAD MUST BE PROVIDED.**

### 230/460 Volt Models - Motor: Nema Epact Efficiency NEMA 12-11 3 phase TEFC (1800 RPM) Service Factor = 1.15

HP	RPM	FRAME	F1 Part #	F2 Part #	230V					460V					BORE DIA.
					FLA	LRA	MCA	* MOP	DISCONNECT SWITCH SIZE AMPS	FLA	LRA	MCA	* MOP	DISCONNECT SWITCH SIZE AMPS	
1	1740	143T	1093600-1-TRI-F1	1093600-1-TRI-F2	3	30	3.75	15	40	1.5	15	1.88	15	40	7/8
1.5	1740	145T	1093600-1.5-TRI-F1	1093600-1.5-TRI-F2	4.4	40	5.5	15	40	2.2	20	2.75	15	40	7/8
2	1740	145T	1093600-2-TRI-F1	1093600-2-TRI-F2	5.6	50	7	15	40	2.8	25	3.50	15	40	7/8
3	1745	182T	1093600-3-TRI-F1	1093600-3-TRI-F2	8	64	10	15	40	4	32	5.00	15	40	1 1/8
5	1745	184T	1093600-5-TRI-F1	1093600-5-TRI-F2	13	92	16.25	25	40	6.5	46	8.13	15	40	1 1/8
7.5	1750	213T	1093600-7.5-TRI-F1	1093600-7.5-TRI-F2	18.4	126	23	40	40	9.2	63	11.50	20	40	1 3/8
10	1750	215T	1093600-10-TRI-F1	1093600-10-TRI-F2	24	161	30	50	40	12	81	15.00	25	40	1 3/8
15	1750	254T	1093600-15-TRI-F1	1093600-15-TRI-F2	36.4	232	45.5	80	80	18.2	116	22.75	40	40	1 5/8
20	1750	256T	1093600-20-TRI-F1	1093600-20-TRI-F2	48.4	290	60.5	100	80	24.2	145	30.25	50	40	1 5/8
25	1760	284T	1093600-25-TRI-F1	1093600-25-TRI-F2	60	364	75	125	80	30	182	37.50	60	40	1 7/8
30	1760	286T	1093600-30-TRI-F1	1093600-30-TRI-F2	70.6	434	88.25	150	100	35.3	217	44.13	70	80	1 7/8
40	1760	324T	1093600-40-TRI-F1	1093600-40-TRI-F2	93.2	580	116.5	200	200	46.6	290	58.25	100	80	2 1/8
50	1765	326T	1093600-50-TRI-F1	1093600-50-TRI-F2	116.6	724	145.75	250	200	58.3	362	72.88	125	80	2 1/8

\* MOP - NOTE: MOP value is for circuit wiring protection only. Actual motor protection must not exceed 1.15 x FLA

### 575 Volt Models - Motor: Nema Epact Efficiency NEMA 12-11 3 phase TEFC (1800 RPM) Service Factor = 1.15

HP	RPM	FRAME	F1 Part #	F2 Part #	575V					BORE DIA.
					FLA	LRA	MCA	* MOP	DISCONNECT SWITCH SIZE AMPS	
1	1740	143T	1093600-1-575-F1	1093600-1-575-F2	1.2	12	1.5	15	40	7/8
1.5	1740	145T	1093600-1.5-575-F1	1093600-1.5-575-F2	1.76	16	2.2	15	40	7/8
2	1740	145T	1093600-2-575-F1	1093600-2-575-F2	2.24	20	2.8	15	40	7/8
3	1745	182T	1093600-3-575-F1	1093600-3-575-F2	3.2	26	4	15	40	1 1/8
5	1745	184T	1093600-5-575-F1	1093600-5-575-F2	5.2	37	6.5	15	40	1 1/8
7.5	1750	213T	1093600-7.5-575-F1	1093600-7.5-575-F2	7.36	50	9.2	15	40	1 3/8
10	1750	215T	1093600-10-575-F1	1093600-10-575-F2	9.6	65	12	20	40	1 3/8
15	1750	254T	1093600-15-575-F1	1093600-15-575-F2	14.56	93	18.2	30	40	1 5/8
20	1750	256T	1093600-20-575-F1	1093600-20-575-F2	19.36	116	24.2	40	40	1 5/8
25	1760	284T	1093600-25-575-F1	1093600-25-575-F2	24	146	30	50	40	1 7/8
30	1760	286T	1093600-30-575-F1	1093600-30-575-F2	28.24	174	35.3	60	40	1 7/8
40	1760	324T	1093600-40-575-F1	1093600-40-575-F2	37.28	232	46.6	80	80	2 1/8
50	1765	326T	1093600-50-575-F1	1093600-50-575-F2	46.64	290	58.3	100	80	2 1/8

\* MOP - NOTE: MOP value is for circuit wiring protection only. Actual motor protection must not exceed 1.15 x FLA

**Maximum Air Over Motor Temperature:  
140°F / 60°C**

### 230/460 Volt Models - Motor: General Purpose 3 phase TEFC (1800 RPM) Service Factor = 1.15

HP	RPM	FRAME	F1 Part #	230V					460V					BORE DIA.
				FLA	LRA	MCA	MOP	DISCONNECT SWITCH SIZE AMPS	FLA	LRA	MCA	* MOP	DISCONNECT SWITCH SIZE AMPS	
3/4	1725	56HC	1096305-.75-TRI-F1	2.8	19.6	3.5	15	40	1.4	9.8	1.75	15	40	5/8

\* MOP - NOTE: MOP value is for circuit wiring protection only. Actual motor protection must not exceed 1.15 x FLA

### 575 Volt Models - Motor: General Purpose 3 phase TEFC (1800 RPM) Service Factor = 1.15

HP	RPM	FRAME	F1 Part #	575V					BORE DIA.
				FLA	LRA	MCA	* MOP	DISCONNECT SWITCH SIZE AMPS	
3/4	1725	56HC	1096305-.75-TRI-F1	1.1	7.8	1.38	15	40	5/8

\* MOP - NOTE: MOP value is for circuit wiring protection only. Actual motor protection must not exceed 1.15 x FLA

## ELECTRICAL DATA - 1 Phase / .75 to 2 HP Models

### 115/230 Volt Models - Motor: 1 phase TEFC w/ Manual Overload (1800 RPM) Service Factor = 1.15

HP	RPM	FRAME	F1 (CH) Part #	115V					230V					BORE DIA.
				FLA	LRA	MCA	MOP	DISCONNECT SWITCH SIZE AMPS	FLA	LRA	MCA	MOP	DISCONNECT SWITCH SIZE AMPS	
3/4	1725	56HC	1096300-.75-DL-F1	11	105	13.75	20	40	5.5	50	6.88	15	40	5/8
1	1725	56HC	1096300-1.0-DL-F1	13.6	125	17	30	40	6.8	65	8.5	15	40	5/8
1.5	1725	56HC	1096300-1.5-DL-F1	15.2	140	19	30	40	7.6	75	9.5	15	40	5/8
2	1725	56HC	1096300-2.0-DL-F1	20	180	25	45	40	10	95	12.5	25	40	5/8

**Maximum Air Over Motor Temperature:  
140°F / 60°C**

## BEFORE START UP CHECKS

- A. Check tightness on all bearing, sheave, and fan wheel set screws.
- B. If fan wheel set screws are loose, check to be sure wheel is not rubbing on housing.
- C. Leak test entire system to make sure all joints are tight.
- D. Ball bearings are prelubricated and do not need grease for start up.
- E. Rotate shaft by hand to be sure it is free.
- F. Check fan and motor for proper rotation and ensure motor overload protection is provided.
- G. Check alignment of fan and motor sheave and belt tension.

## AFTER FIRST 48 HRS. OF OPERATION

- A. Check all points under BEFORE START UP CHECKS (above)
- B. Belts have acquired their permanent stretch. Readjust motor mount to take up slack in belts.

## PERIODIC SERVICE & MAINTENANCE

- A. Check all moving parts for wear every six months.
- B. Check bearing collar set screws for tightness every six months.

## BALL & SLEEVE BEARINGS

### A. Ball Bearings

1. Motor bearings - All ball bearings are prelubricated and do not require addition of grease at time of installation. However, periodic cleaning out and renewal of grease is necessary. Please note that extreme care must be exercised to prevent foreign matter from entering the bearing. It is also important to avoid over-greasing. Only a high grade, clean mineral grease having the following characteristics should be used.
  - a. Consistency a little stiffer than that of vaseline, maintained over the operating temperature range; melting point preferably over 302°F (150°C), freedom from separation of oil and soap under operating and storage conditions; and freedom from abrasive matter, acid, alkali and moisture.
  - b. Specific greasing instructions are to be found on a tag attached to the motor and should generally be adhered to.

## BALL & SLEEVE BEARINGS (cont'd)

2. Fan Shaft Bearings - All ball bearings are prelubricated and do not require addition of grease at time of installation. However, periodic cleaning out and renewal of grease is necessary. Internal bearings are accessible through access panel in cabinet. Units that are equipped with extended lube lines will have grease fittings for internal bearings on drive end panel of blower section. Apply grease while bearings are running, adding slowly until a slight bleeding of grease from the seals is noted. For greasing units with extended lube lines, remove access door so bearing can be viewed when greasing.

## DO NOT OVER LUBRICATE

The lubrication interval varies with the period of operation and temperature of the ambient air. The following interval is recommended using Mobilgrease XHP 222 or equivalent:

Temperature Range (°F)	Continuous Operation	12 Hr./Day Operation
60 - 80	2 years	4 years
81 - 100	1 1/2 years	3 years
101 - 120	1 year	2 years
121 - 140	3/4 year	1 1/4 years

## REPLACEMENT PARTS

When replacement parts are required, furnish factory with unit model number and serial number as shown on serial plate on drive end of blower section.

## APPROXIMATE NET WEIGHTS (without Motor)

DESCRIPTION	UNIT SIZE													
	103	104	106	108	111	114	117	122	128	137	141	150	164	182
	FAN HEAD													
<b>SINGLE WALL - not insulated</b>	360	475	589	646	908	948	973	1156	1590	1650	1801	2059	2532	3162
	HEATING COILS ALUMINUM FINs													
<b>4 ROWS</b>	116	148	190	253	315	441	541	565	695	1005	1105	1235	1723	2253
<b>6 ROWS</b>	152	208	273	362	455	631	781	816	1001	1389	1596	1789	2439	3336
<b>8 ROWS</b>	209	266	356	475	593	828	1021	1058	1305	1790	2149	2325	3172	4341
<b>10 ROWS</b>	236	328	447	580	733	1018	1252	1312	1677	2202	2578	2869	3872	5260
<b>FLAT FILTER SECTION (BOLT ON)</b>	39	49	62	86	118	140	161	189	232	278	303	342	416	520
<b>ANGULAR FILTER SECTION</b>	N/A	N/A	N/A	N/A	N/A	507	600	674	828	899	1113	1159	1426	1755

## APPROXIMATE MOTOR WEIGHTS

### Motor: Nema Epact Efficiency NEMA 12-11 3 phase TEFC (1800 RPM)

HP	1	1.5	2	3	5	7.5	10	15	20	25	30	40	50
Weight	40	48	51	89	101	136	160	270	306	372	387	521	565

### Motor: General Purpose 3 phase TEFC

HP	3/4
Weight - lbs.	25

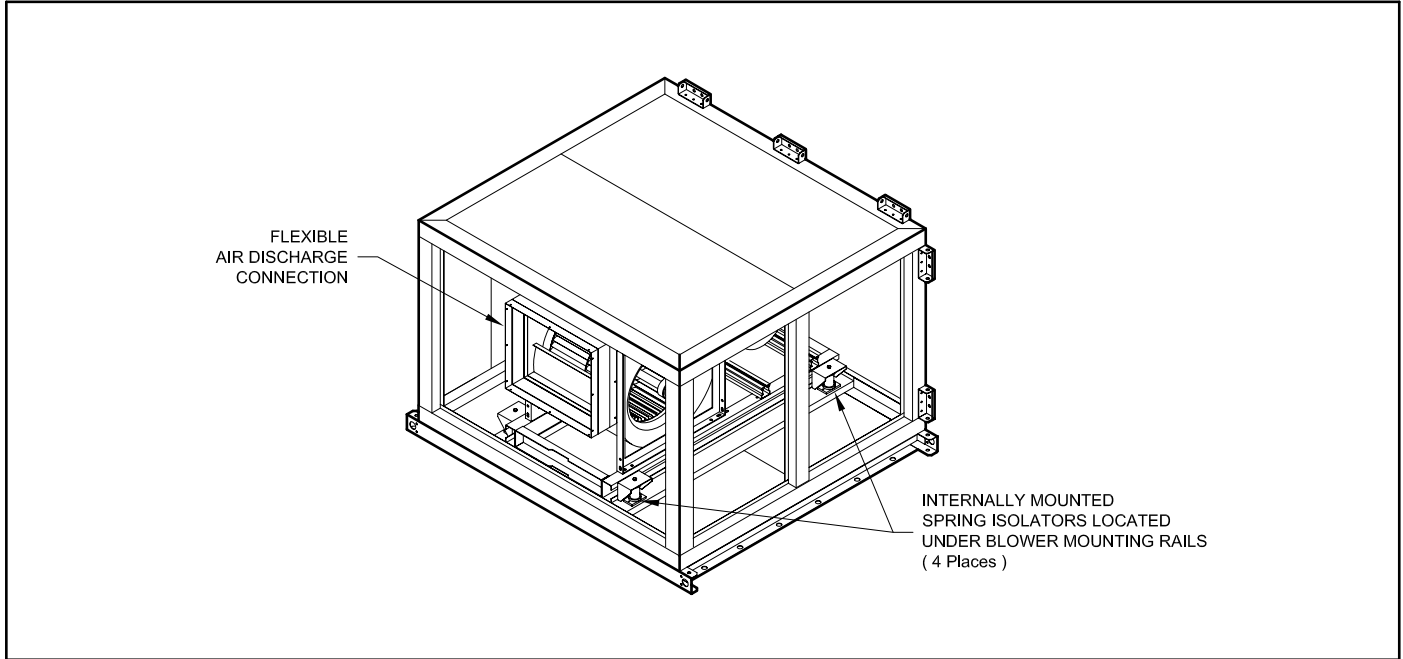
### Motor: 1 phase TEFC w/ Manual Overload

HP	3/4	1	1.5	2
Weight - lbs.	30	33	41	51

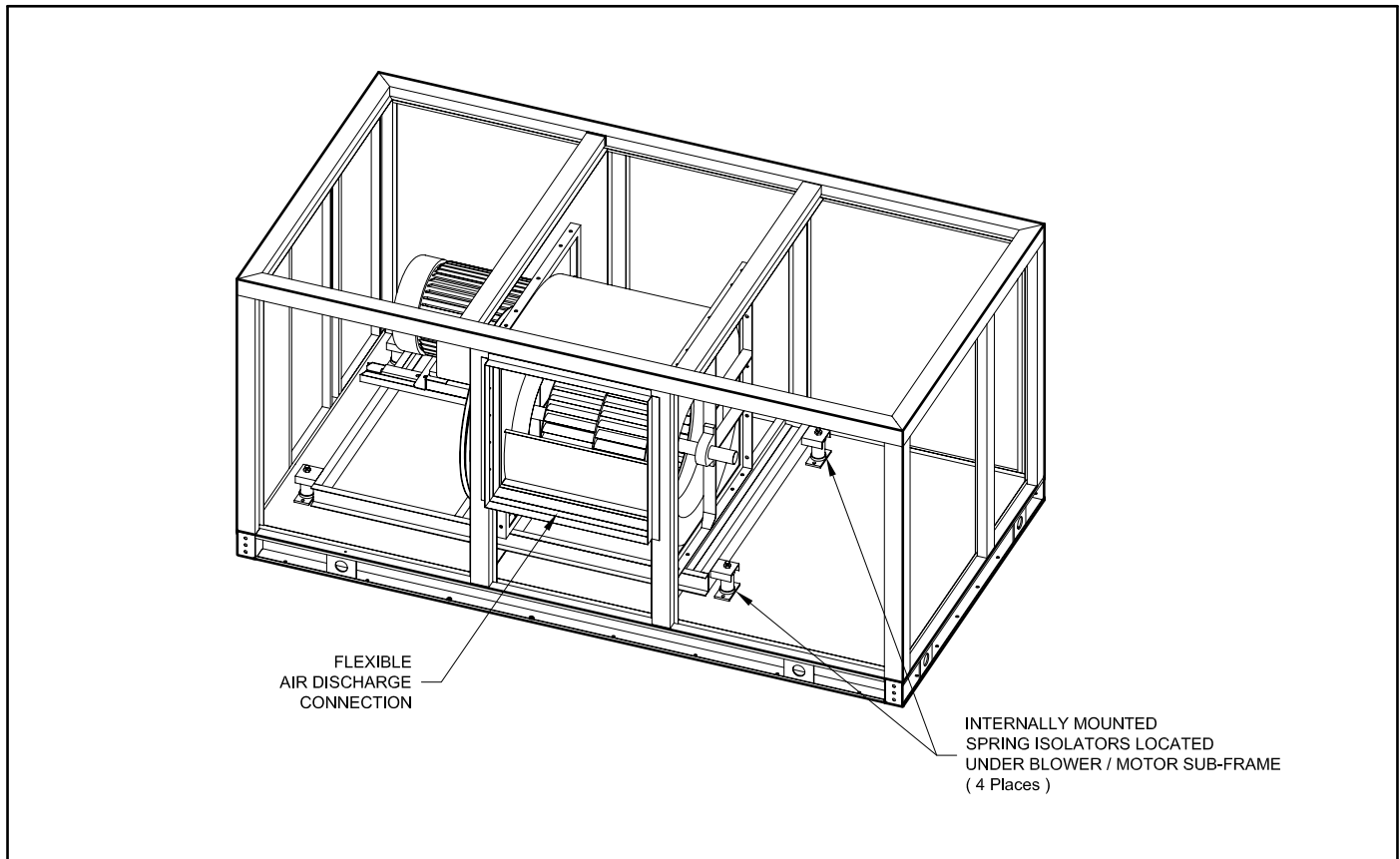
CONSULT FACTORY FOR PROPER SPRING SELECTION

### AB FAN HEAD: Models AB103 - AB128

Note: Rubber isolator style used on Model 108



### AB FAN HEAD: Models AB137 - AB182



## FINISHED GOODS WARRANTY

The terms and conditions as described below in the General Warranty Policy cover all products manufactured by National Refrigeration.

### GENERAL WARRANTY POLICY

Subject to the terms and conditions hereof, the Company warrants all Products, including Service Parts, manufactured by the Company to be free of defects in material or workmanship, under normal use and application for a period of one (1) year from the original date of installation, or eighteen (18) months from the date of shipment from the Company, whichever occurs first. Any replacement part(s) so supplied will be warranted for the balance of the product's original warranty. The part(s) to be replaced must be made available in exchange for the replacement part(s) and reasonable proof of the original installation date of the product must be presented in order to establish the effective date of the warranty, failing which, the effective date will be based upon the date of manufacture plus thirty (30) days. Any labour, material, refrigerant, transportation, freight or other charges incurred in connection with the performance of this warranty will be the responsibility of the owner at the current rates and prices then in effect. This warranty may be transferred to a subsequent owner of the product.

### THIS WARRANTY DOES NOT COVER

(a) Damages caused by accident, abuse, negligence, misuse, riot, fire, flood, or Acts of God (b) damages caused by operating the product in a corrosive atmosphere (c) damages caused by any unauthorized alteration or repair of the system affecting the product's reliability or performance (d) damages caused by improper matching or application of the product or the product's components (e) damages caused by failing to provide routine and proper maintenance or service to the product (f) expenses incurred for the erecting, disconnecting, or dismantling the product (g) parts used in connection with normal maintenance, such as filters or belts (h) products no longer at the site of the original installation (i) products installed or operated other than in accordance with the printed instructions, with the local installation or building codes and with good trade practices (j) products lost or stolen.

**No one is authorized to change this WARRANTY** or to create for or on behalf of the Company any other obligation or liability in connection with the Product(s). There is no other representation, warranty or condition in any respect, expressed or implied, made by or binding upon the Company other than the above or as provided by provincial or state law and which cannot be limited or excluded by such law, nor will we be liable in any way for incidental, consequential, or special damages however caused.

The provisions of this additional written warranty are in addition to and not a modification of or subtraction from the statutory warranties and other rights and remedies provided by Federal, Provincial or State laws.

## PROJECT INFORMATION

System	
Model Number	Date of Start-Up
Serial Number	Service Contractor
Refrigerant	Phone
Electrical Supply	Fax



**NATIONAL REFRIGERATION &  
AIR CONDITIONING CANADA CORP.**  
159 Roy Blvd.  
Brantford Ontario Canada N3R 7K1  
PHONE: (519) 751-0444 800-463-9517  
FAX (519) 753-1140 [www.t-rp.com](http://www.t-rp.com)

